

Shallow-field Mobile Demagnetizer for Larger Surfaces

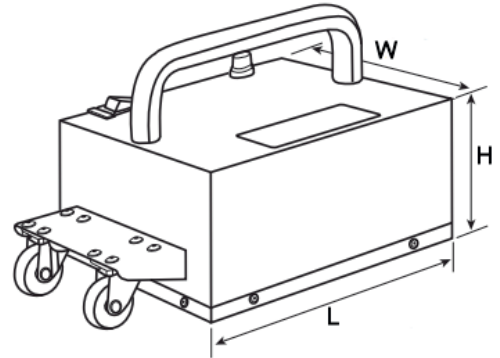

- Easy to manipulate with inbuilt handle, wheel mounted.
- Perfect for passing over large flat surfaces eg. mold bases, large steel blocks.

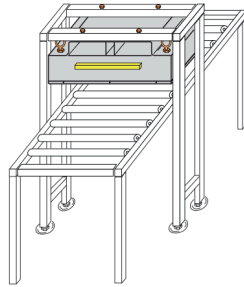

Product Code: MD

All dimensions in metric units

Model	Overall Dimensions (L x W x H)	Active Area	Duty Cycle D.C (%)	Voltage (VAC) / Current (A)	Weight (Kgs)
MD 300	290 x 210 x 95	290 x 210	100	110~220 / 5	10

Shallow-field Mobile Demagnetizer for Larger Volume Smaller Components



- Suitable for large volume of small components to be demagnetised rapidly.
- Adjustable power.
- Parts can pass through the funnel mouth to the sloped tunnel in large quantities.

Product Code: FD

All dimensions in metric units

Model	Overall Dimensions (L x W x H)	Duty Cycle D.C (%)	Voltage (VAC), Current (A)	Weight (Kgs)
FD 230	200 x 280 x 390	100	110/220 VAC, 12/6 A	30

