



Product Code: PMH

All dimensions in metric units

Model No.	Dimension (mm)					Weight (Kg)
	Ø A	B	C	E	H	
PMH-150	150	208	208	322	470	42.5
PMH-200	200	208	258	322	470	53
PMH-250	250	258	358	372	500	65
PMH-2020	-	208	208	322	300	51
PMH-2025	-	208	258	322	300	60
PMH-2525	-	258	258	372	300	66
PMH-2530	-	258	308	372	300	71
PMH-2535	-	258	308	372	300	80
PMH-2540	-	208	408	372	300	90
PMH-2545	-	258	458	372	300	100
PMH-2550	-	208	508	372	300	110
PMH-2555	-	258	558	372	300	120
PMH-2560	-	258	608	372	300	130

Due to continuous upgradation in design there could be changes in specification. Other sizes on request. Before ordering, contact Supreme Magnets or your nearest dealer to confirm the suitability of this model for your application.



- The Plate Magnet Housing is a complete solution, consisting of Plate Magnets hinged to the housing like doors for easy cleaning in a self contained housing with an inlet and outlet for raw material entry and egress.
- A wedge-shaped baffle at the top of the housing helps to break up aggregated products and direct material flow over the unit's two powerful Plate Magnets.
- The high power rare earth plate magnets ensure capture of all sizes of contamination.
- Available in Square or Round flange as desired and SS304 or 316 construction.



Plate Magnet Housing are widely used in food, pharmacy, tobacco, chemical industries to remove tramp iron and ferrous fines from flow-resistant bulk materials that are easy to aggregate and choke. The stainless steel housings can be easily installed to enclosed spouting line or directly mounted on processing equipment.

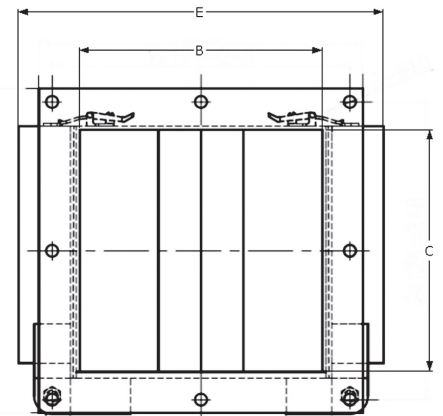
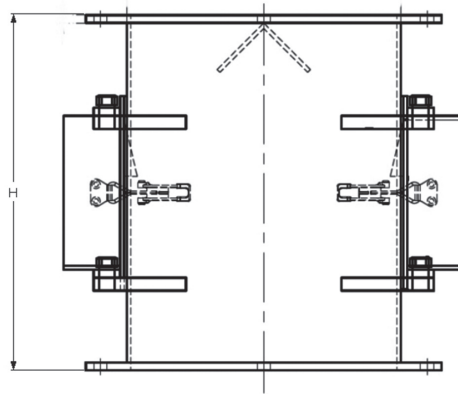

Square Flange

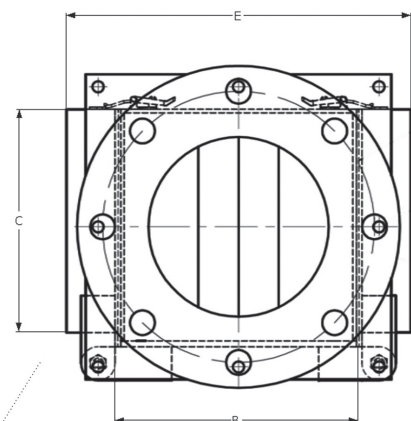
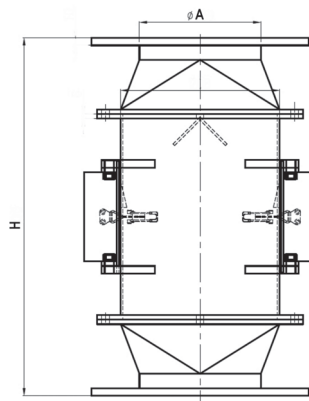

Round Flange