



- These lifting magnets are designed to be compact, low weight, high strength and reliable with full respect to industrial safety.
- Unique EPM technique using double magnet system.
- EPM needs electricity only during switching magnet ON and OFF.
- Can be controlled by a single operator staying at a safe distance.
- No battery back up is needed.
- Over 95% saving of electricity as compared to conventional electro magnets.
- Can be supplied with fixed structure having provision for shifting magnets to handle plates with various sizes.
- Special safety - Will not drop when load is hanging due to incorporation of safety contact-less switch.
- Each magnet is hanged from suspension springs to adjust to the bendness of plates.



- Ideal for handling single plates in stock yard of large fabrication shops.
- Loading of plates on flame cutting machines.
- Most effective in ship building industries.
- Can handle both small plates and large plates by selectively choosing the magnets in contact with plate.
- Telescopic spreader beam with adjustable arm for lifting plates 12M long and above and weighing 25 MT are available.

Latest technology for handling and lifting single plates of length upto 16mtr and width upto 4mtr. Completely eliminates the older electromagnetic conventional technology and its associated liabilities such as heavy electricity consumption, duty cycle adherence, battery backup, coil burnout and frequent maintenance.

Requiring hardly any maintenance and does not consume electricity during actual lift operation, the highly reliable LIFTON EPML P series represents the answer to plate lifting operations in shipyards, stockyards, flame-cutting environments and similar single plate handling environments.

The magnetic power is generated by a double magnet combination driven by a brief electrical impulse only during charging and discharging. This generates a concentrated and controlled power during the period of actual operation while requiring no electricity and therefore saves nearly 95% power.

- Suitable for indoor and outdoor use.
- Control Panel with operator pendant control wired or wireless.
- Can be made to any size and capacity.

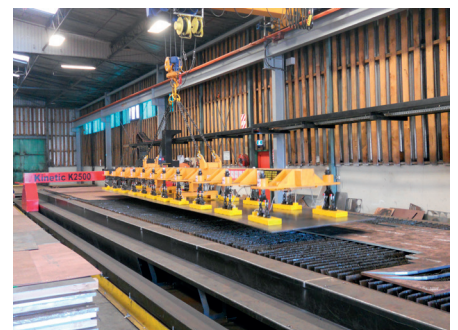

ElectroPermanent Plate Lifting Magnet

VARIOUS MODELS FOR DIFFERENT APPLICATIONS CAN BE SUPPLIED AS MENTIONED BELOW

- Fixed beams with steel tube structure having 2/4/6 cross beams with 2 magnets on each cross beam.
- Fixed or telescopic beam for handling wide plates to long sections.
- Special modular systems are tailor made by adapting them to the size of the plate and flame cut pieces. This allows easy and fast loading and unloading operation on any type cutting machine like plasma, oxyacetylene, laser. It quickly clears the table from cut plates and skeleton in single move to make machine available for next loading, thus saving space and time.

FLEXIBILITY

- Compact Modules (Single magnet modules can be added for added capacity to existing beam). No need to overhaul existing crane infrastructure.
- Electropermanent (EPM) Technology does not require constant supply of electricity to sustain magnetism thereby 95% savings in electrical consumption compared to older Electro Lifters.
- No more coil burnout due to operator forgetfulness to adhere to concept of Duty cycle of 60% or 70% in older Electro Lifters.
- No more downtime and frequent maintenance or repair of the lifting magnets as the magnets themselves hardly spoil due to the above reasons.

CONFIGURATION GUIDELINES

- Upto 6 Mtr Long Plates from thickness 5mm onwards.
Use the EPML P/4 system comprising of 2 magnet modules totaling 4 magnets. Each module consisting of 2 magnets each either in a chain/sling suspension or spring enabled housing suspended from a fixed beam structure.
- Upto 12 Mtr Long Plates from thickness 5mm onwards.
Use the EPML P/10 system comprising of 10 magnets. Each module consisting of 2 magnets either in a chain/sling suspension or spring enabled housing suspended from a fixed beam structure or telescopic beam. For smaller plate sizes of 6 Mtr or 9 Mtr, selective activation of the magnets are possible. The decision to recommend a single housing or individual suspended magnets will depend on plate handling characteristics and behavior. If the plates are loosely stacked, individual magnet suspension performs better. If the plates are neatly stacked, a double magnet housing is suitable.
- Upto 16 Mtr Long Plates from thickness 5mm onwards.
Use the EPML P/12 system comprising of 6 magnet modules totaling 12 magnets. Each module consisting of 2 magnets either in a chain/sling suspension or spring enabled housing suspended from a telescopic beam.
- Can handle both small plates and large plates by moving telescopic arm which hangs magnets.



TECHNICAL AND DIMENSION DATA : SUBJECT TO MODIFICATION

Every plate lifting requirement requires a near custom construction and field characteristics may require alteration of dimension data. LIFTON reserves the right to alter/amend any of the below data to suit the application at hand.

PROPERTIES AND DIRECTIONS OF USE

If the thickness is less and the length is more than 2000 mm, then, instead of a single high capacity magnet, more than one magnet of lower capacity is used, making sure that the overhanging on width is not more than 800 mm and length 1000 mm. For Example if you have to lift a plate of say 6000 x 2000 x 12 mm thick, you need to hang atleast 4 Sets of magnets (Each set consist of 2 Nos. magnet, side ways) and they are hanged from a spreader beam of 4000 mm x 1000 mm.

For handling plates of larger sizes, we recommend Telescopic Plate Handling System which is basically a spreader beam having 2 sets of fixed magnets and 2 set of magnets moving between 800 to 1100 mm each side. The magnets are hanged by Spring suspension box with loose chain so that it takes care of the bend of the plates available in market.

STANDARD / OPTIONS

- Switch selectable capability for selecting 4/8/6/10/12 magnets (STANDARD, depending on model).
- Radio Remote Control with PICK-UP/FULL-MAG / DEMAG / SAFE / OPEN / CLOSE functions (OPTION).
- Optional INTEGRATION WITH Operator Pendant.
- Integration into existing / new Crane Remote possible (OPTION).
- Cable Spring Drum with 12m cable, plug and socket (OPTION) Lamp block, pendant and T/R Control Panel with Saturation control system (STANDARD).

SAFETY FACTOR

LIFTON strictly adheres to a safety factor of 3:1 for all individual EPML lifting magnets. The total system with Fixed beam in its complete assembly will sustain a load of 1.5 : 1 for MILD STEEL plates and these are in conformity with the provisions of the Machinery Directive 98/37/EG, harmonized standards EN-292-1, EN-292-2 and with national implementing legislation.

CAUTION : The maximum rated lift is based upon lifting clean, smooth, flat, low-carbon steel plate, with the full area of the magnet's lifting surface in contact with the load. De-rating is required for round jobs, rusted jobs or alloy steels. Do not use on material less than 5mm thickness. Safety Manual contains more detailed ratings.

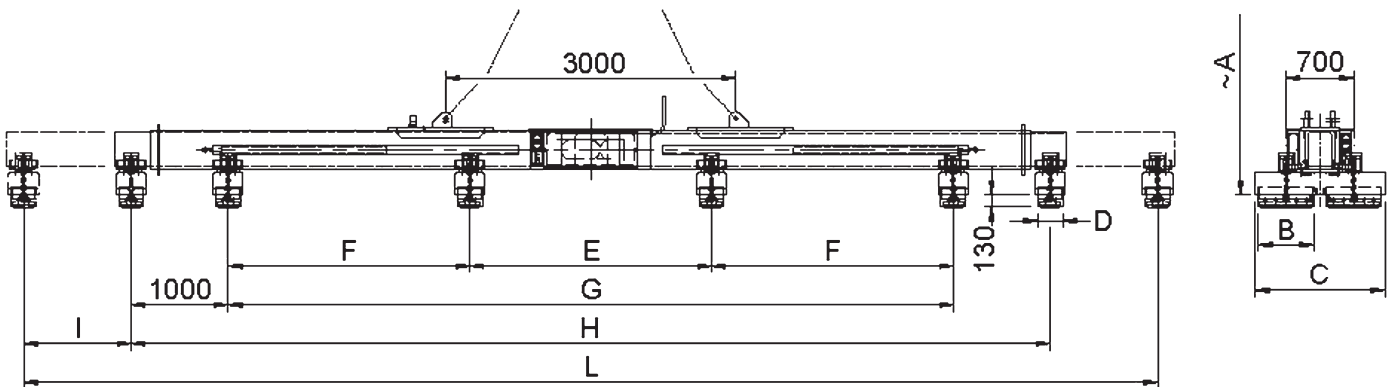

Product Code: EPML P

All dimensions in metric units

Model No.	A	B	C	D	E	F	G	H	I	L	WEIGHT	LENGTH	WIDTH	MIN THICK	SWL
EPML P/4	System of 4 magnets with spring dampers hanging from a Spreader Beam														
4T	2000	325	1250	235	3000	3050					1200	6000	3500	5	4000
8T	2000	600	1250	230	3000	3050					1200	6000	3500	8	8000
10T	2000	600	1550	250	3000	4000					1500	6000	3500	10	10000
EPML P/8 & P/10	System of 8 or 10 magnets with spring dampers hanging from a Spreader Beam. 8 Magnets for 9 Mtr Plate & 10 Magnets for 12 Mtr Plates														
6T	2500	330	1250	240	2500	1450		5000	1250	7500	2750	9000	3500	5	6000
8T	2500	330	1250	240	2500	1650		6000	1700	9500	2950	12000	3500	6	8000
10T	2500	350	1250	250	2500	1650		6000	1700	9500	2950	12000	3500	8	10000
12T	2500	415	1250	235	2500	1650		6000	1700	9500	2950	12000	3500	10	12000
15T	2500	505	1250	235	2500	1650		6000	1700	9500	2950	12000	3500	15	15000
EPML P/12	System of 12 magnets with spring dampers hanging from a Spreader Beam														
10T	2500	330	1250	240	2500	1650	6000	8000	1350	10000	3850	16000	3500	5	10000
12T	2500	350	1250	250	2500	1650	6000	10000	1650	12500	4250	16000	3500	8	12000
15T	2500	415	1250	235	2500	1650	6000	10000	1650	12500	4250	16000	3500	10	15000
20T	2500	505	1250	235	2500	1650	6000	10000	1650	12500	5450	16000	3500	15	20000
25T	2500	630	1500	250	2500	1850	6000	10000	1650	12500	6000	16000	3500	15	25000

Due to continuous upgradation in design there could be changes in specification. Other sizes on request. Before ordering, contact Supreme Magnets or your nearest dealer to confirm the suitability of this model for your application.