

MICROGRIND ROUND

PM

Microfine Pole Round Magnetic Chuck

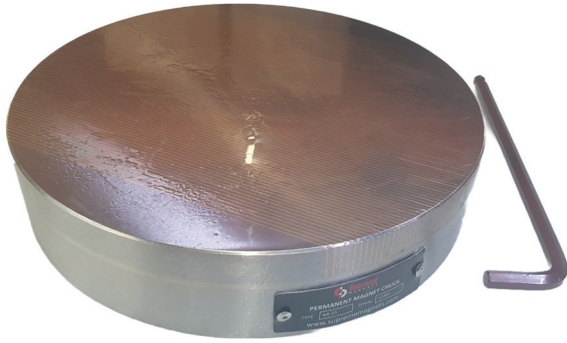

- Steel and brass laminated top plate.
- Fully extended poles- minimum loss of working area.
- Standard Allen Key for easy use.
- Extremely low profile for wheel area.
- Made with super powerful NdFeB new generation magnets.
- Extension plate is suitable for clamping directly by 3 jaw chuck.
- Unique design of the chuck minimizes the deflection of top plate when switched ON/OFF,resulting in better job accuracy.



- Ideal for cylindrical or rotatory grinding.
- Enables the grinding of thin objects and small objects that has hitherto been difficult.

Product Code : NR All dimensions in metric units

Model No.	DIA (OD)	Pole Pitch	H
NR-10	100	2 (1.5+0.5)	45
NR-13	130		
NR-16	160		
NR-20	200		
NR-25	250		
NR-30	300		
NR-35	350		48
NR-40	400		
NR-45	450		
NR-50	500		

Due to continuous upgradation in design there could be changes in specification. Other sizes on request. Before ordering, contact Supreme Magnets or your nearest dealer to confirm the suitability of this model for your application.

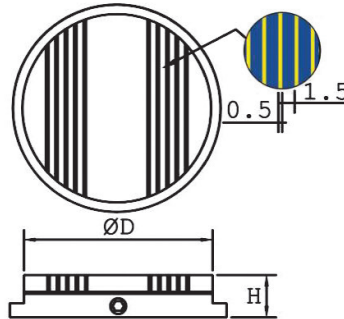

- Attached to rotary grinders for operation.
- Back plate with tapped hole can be made on request.

STRONGRIND ROUND

PM

Universal Pole Round Magnetic Chuck



- Steel and brass laminated top plate.
- Fully extended poles- minimum loss of working area.
- Made with high power permanent magnets.
- Detachable handle for easy use.
- Holding force of up to 140N/cm² (14Kg/cm²)



- Suitable for medium and big components for grinding, lathe and even special milling operations.

Product Code : SR All dimensions in metric units

Model No.	DIA (OD)	Pole Pitch	H
FR-10	100	31 (15+4+12)	70
FR-12	120		
FR-15	150		
FR-18	180		
FR-20	200		
FR-25	250		
FR-30	300		73
FR-35	350		
FR-40	400		

Due to continuous upgradation in design there could be changes in specification. Other sizes on request. Before ordering, contact Supreme Magnets or your nearest dealer to confirm the suitability of this model for your application.

