

DIMENSIONS

NOTES:

1. LEADS: 18GA STRANDED. LEADS CAN BE ANY COLOR EXCEPT GREEN OR GREEN WITH YELLOW STRIPE.
2. GROUNDING OR EARTHING PROVISIONS: USE HOLES AS INDICATED FOR GROUNDING OR EARTHING. REFER TO APPROPRIATE LISTING OR REGULATORY AGENCY FOR PROPER METHOD OF GROUNDING OR EARTHING.
3. MOTOR IDENTIFICATION: MANUFACTURER'S NAME, MODEL NUMBER, VOLTAGE, FREQUENCY, INSPECTOR'S CODE, DATE OF MANUFACTURE, AGENCY RECOGNITION CODE; PLANT LOCATION CODE AND COUNTRY OF ORIGIN
4. MOUNTING MUST NOT RESTRICT THIS DIAMETER.

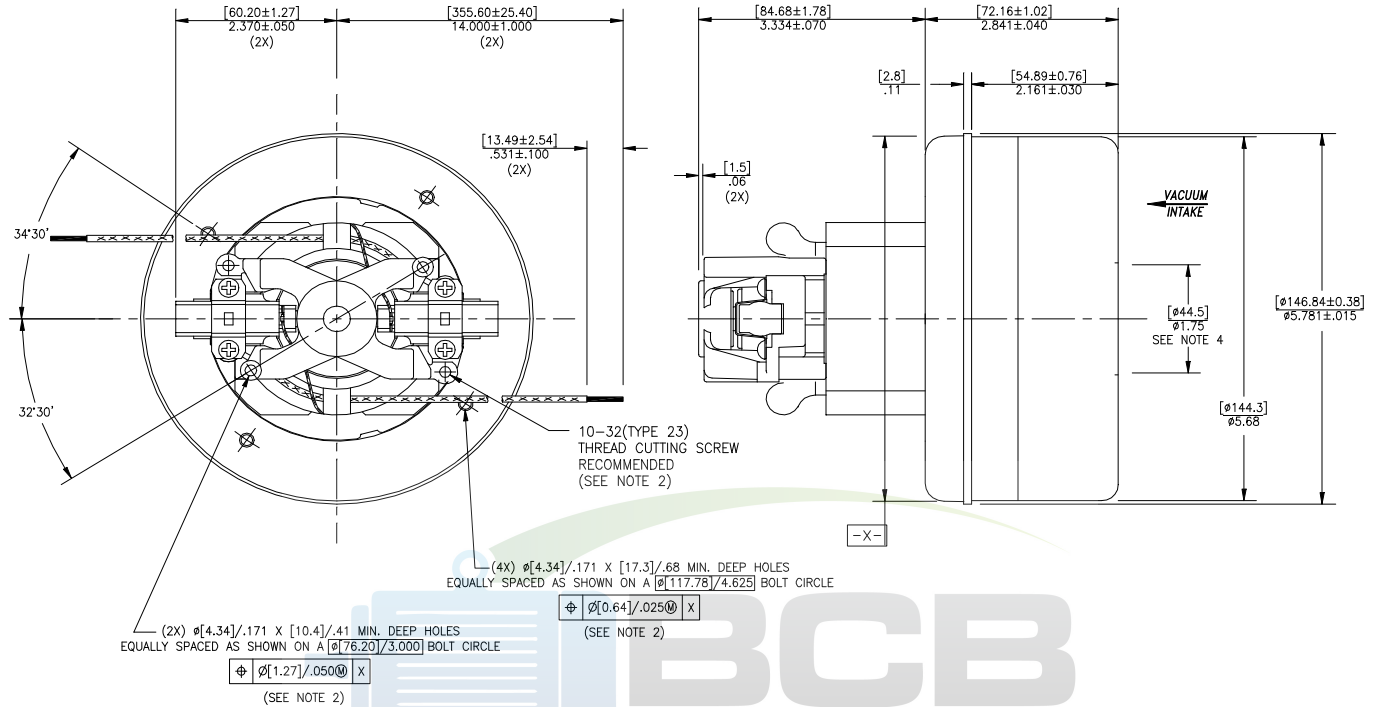

IMPORTANT NOTE: Pictorial and dimensional data are subject to change without notice. Contact factory for current revision levels.

WARNING - AMETEK Lamb Electric thru-flow vacuum motors must never be used in applications in which wet or moist conditions are involved, where dry chemicals or other volatile materials are present, or where airflow may be restricted or blocked. Such motors are designed to permit the vacuumed air to pass over the electrical winding to cool it. Thus any foam, liquid (including water), dry chemical, or other foreign substance coming in contact with electrical conductors could cause combustion (depending on volatility) or electrical shock. Failure to observe these precautions could result in property damage and severe personal injury, including death in extreme cases. All applications incorporating Lamb Electric motors should be submitted to Underwriters Laboratories Inc. or other appropriate organizations or agencies for testing specifically related to the safety of your equipment.

