

MaEr Micro-motor

www.maerwdj.com

Professional · Honest · Human Oriented

外转子风机 AXIAL FAN MOTOR

BCB SALES & SERVICE

PH : 03 9546 3833

FAX : 03 9546 3356

Φ 600

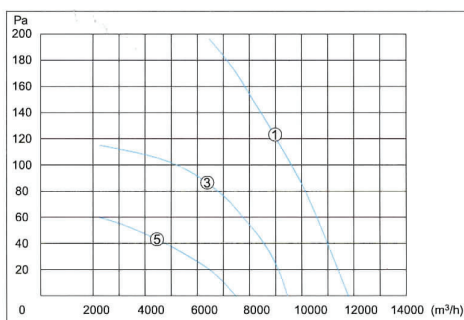
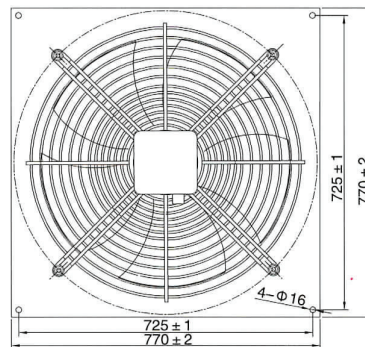
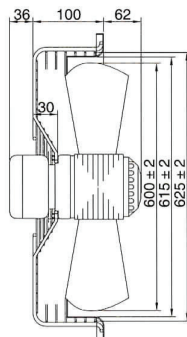
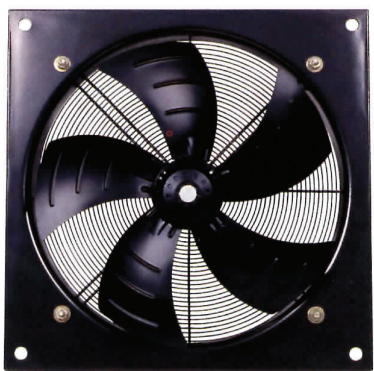
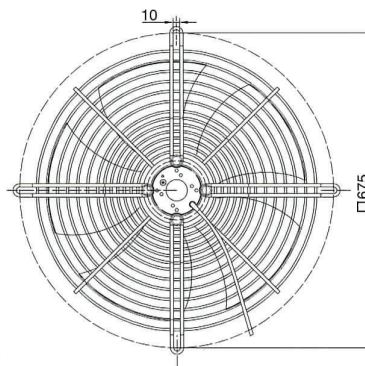
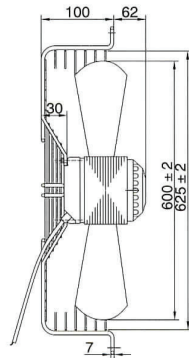
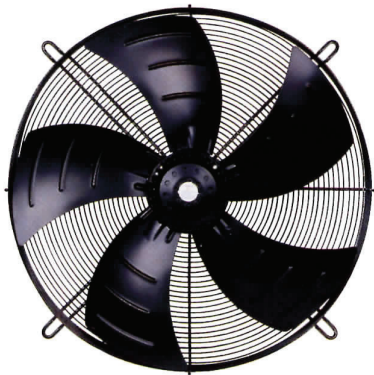

50Hz

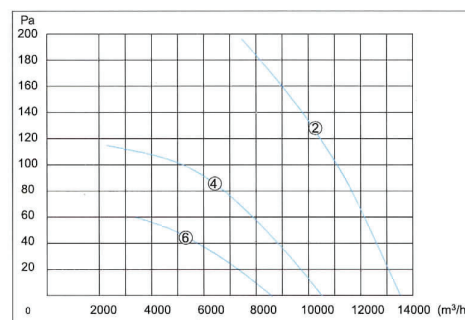

60Hz

型号	电压	频率	曲线编号	风量	转速	输入功率	电流	电容器	噪声	净重
MODEL	VOLTAGE V	FREQUENCY Hz	CURVE NO.	AIR VOLUME m³/h	SPEED r/min	INPUT W	CURRENT A	CAPACITANCE μ F/450V	NOISE dB(A)	NET Kg
YDWF102L60P4-675N-600	220	50	①	11800	1380	710	3.3	20	76	13.5
		60	②	13500	1600	843	3.85		80	
YSWF102L60P4-675N-600	380	50	①	11800	1380	700	1.45	/	76	13.5
		60	②	13500	1649	840	1.43		80	
YDWF102L60P6-675N-600	220	50	③	9450	930	410	1.9	12	71	13.5
		60	④	10500	1100	480	2.2		74	
YSWF102L60P6-675N-600	380	50	③	9450	930	410	1.1	/	71	13.5
		60	④	10500	1070	510	1.01		74	
YDWF102L60P8-675N-600	220	50	⑤	7400	690	265	1.3	10	68	13.5
		60	⑥	8600	820	340	1.62		70	