

9x7 tight fan deck with 600W motor

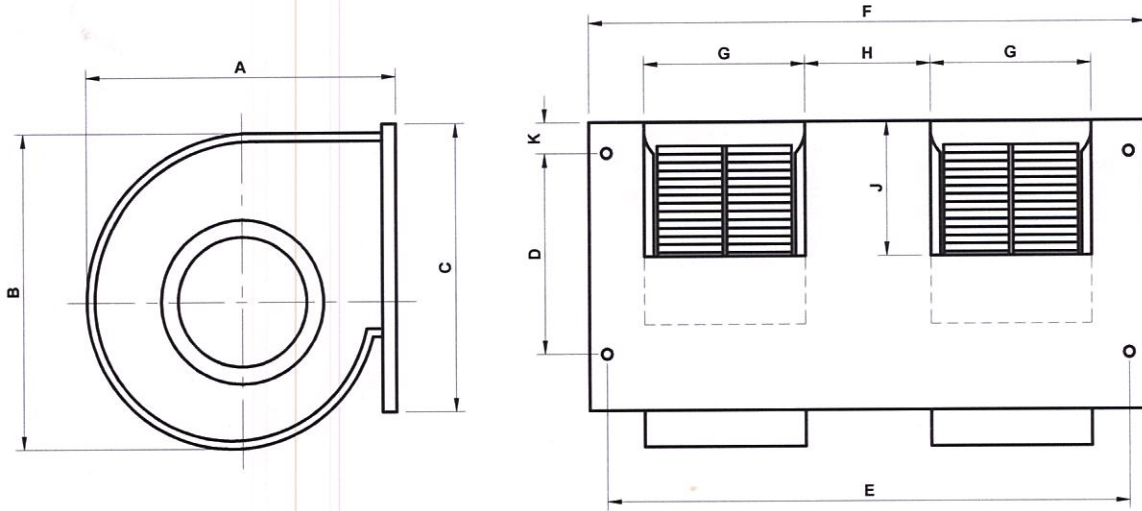

Part Number	A	B	C	D	E	F	G	H	J	K	Nutsert
FD 9x7T-600-05	320	325	311	262	765	816	235	227	169	25	M6
FD 9x7T-600-01	320	325	314	257	762	814	235	239	169	25	M6

Motor					
Rated Output 600W	Supply 240V/50Hz	Rated RPM 1330	Rated Current 4.0 amps	Capacitor 15uF/440V	Insulation Class B 130
Enclosure IP20	Thermal Protection Auto Reset Overload		Duty AOM		

Wheels	
Glass Filled Nylon with plated mild steel hub	

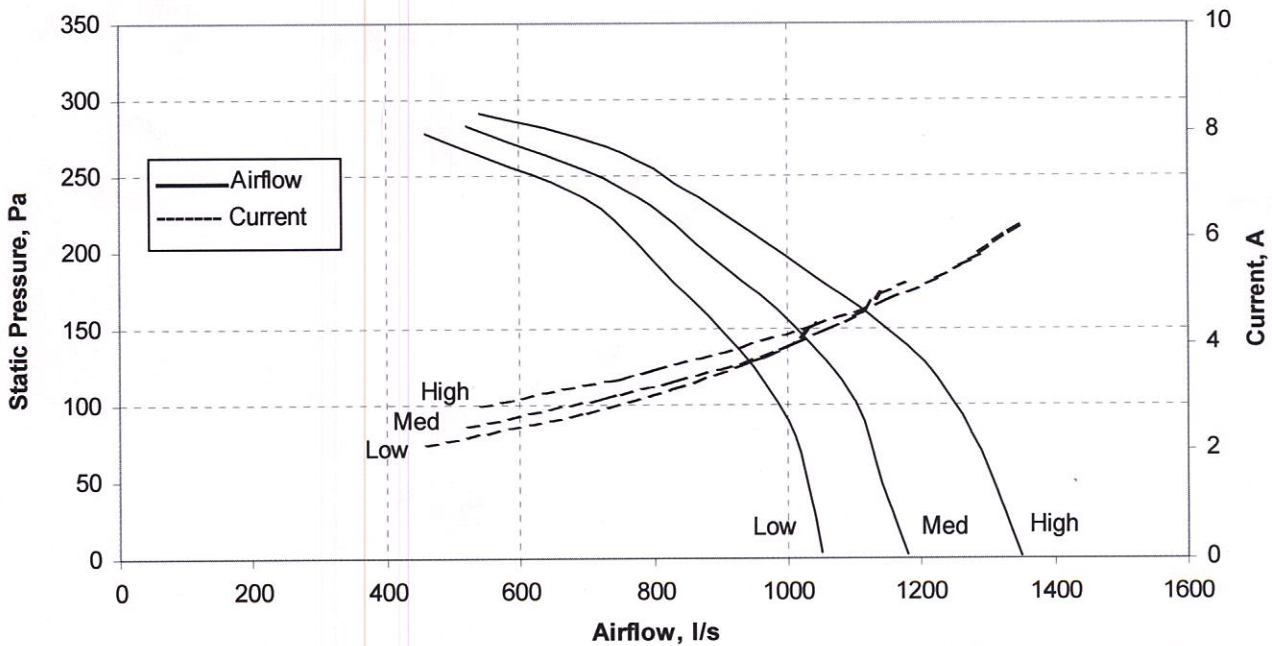

Dimensions

Product Data

Performance