

THIRD ANGLE PROJECTION

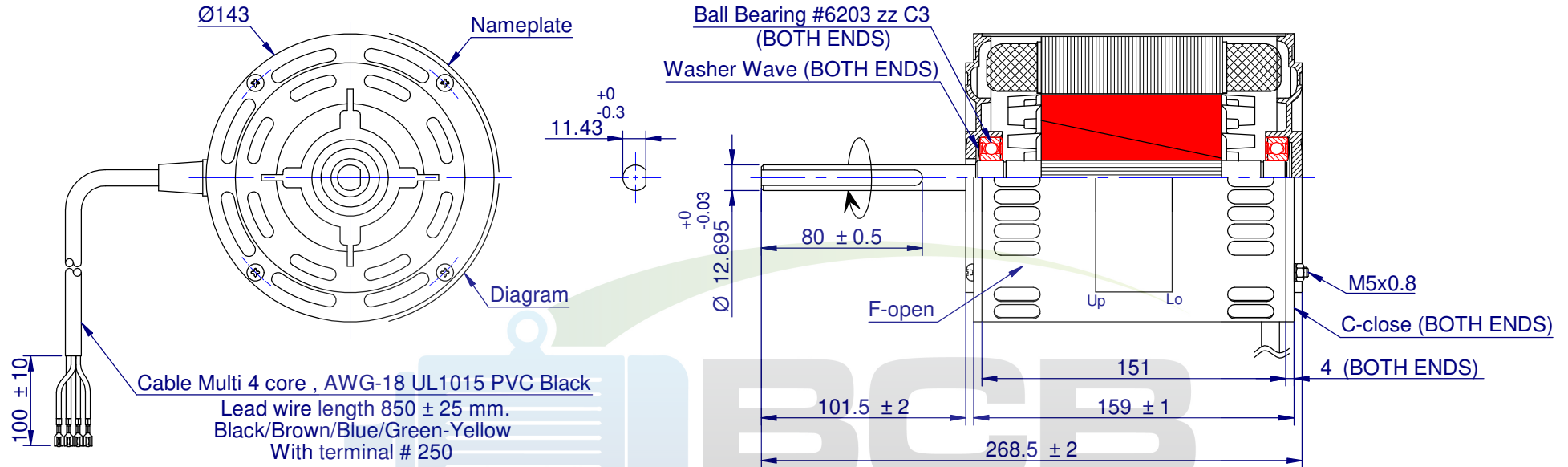

**Fasco Model
80855BRVA-A16
Rebranded as
Marathon**

BCB Sales & Service (Vic)

DOC No. _____
By: _____
Date: _____
DOC No. _____

MOTOR SPECIFICATION

Q.R. NO.		QR230047		CUSTOMER PART NO.		80855BRVA-A16S			
MOTOR RATING	VOLTS	240	Hz	50	PH	1	DUTY	A.O.M.	
	RPM.	1295				6.8	AMPS		
	NOM. OUTPUT	950 WATTS							
ROTATION		CLOCKWISE DRIVE END							
CAPACITOR	START	---	$\mu\text{F/V}$	RUN	25/440		$\mu\text{F/V}$		
MOTOR TYPE	CSR		INSULATION CLASS		B130				
THERMAL PROTECTION		AUTO RESET OVERLOAD							
DATA TEST NO.	W443-2912-SL		PAINT/ COLOUR	GREY #5082					

SPECIAL REQUIREMENTS:

- 1) After the motor is complete, applied rust proof oil at shaft end.
- 2) The tensile strength of each lead wire at least 4 Kgs.
- 3) The runout of the shaft end circumference 0.10 mm.
- 4) Capacitor supplied by Customer.
- 5) Motor to be packed in single carton.

UNLESS OTHERWISE SPECIFIED :
DIMENSIONS ARE IN MM.
TOLERANCES
DECIMALS ANGULAR
X ± 1.0 $\pm 30'$
.XX ± 0.1
THIS DRAWING REMAINS THE PROPERTY OF REGAL BELOIT AUSTRALIA AND MAY NOT BE USED, COPIED OR ISSUED WITHOUT WRITTEN PERMISSION FROM REGAL BELOIT AUSTRALIA

MOTOR WEIGHT			---	kg.
DRAWN	THANATCHA	05/08/2023		
CHECKED	EKAPHOP	05/08/2023		
RELEASED	WEERAPAN	05/08/2023		
SCALE	N.T.S.			

marathon Motors				DESIGNED AND MANUFACTURED TO AUSTRALIAN STANDARDS & SPECIFICATIONS			
MODEL		8M855BRVA-A16S		DDMMYYXXXX			
VOLTS	240	R.P.M.	1295	CLASS	B130	Hz	50
WATTS	950	TYPE	CSR	$\mu\text{F/V}$	R 25/440	Ph	1
AMPS	6.8	DUTY	AOM	PROT.	AUTO		
WARNING MOTOR FITTED WITH INTERNAL AUTO RESET OVERLOAD AND MAY RESTART WITHOUT WARNING							

NAMEPLATE

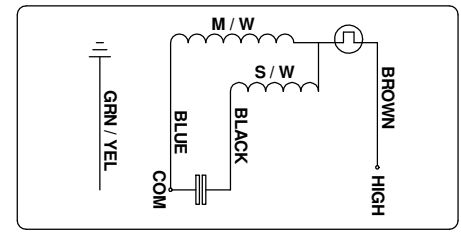

DIAGRAM

BCB
Sales & Service (Vic)
sales@bcbsales.com.au
03 9546 3833

FRAME	MOTOR		
STATUS	R	950W 4P 1SP 240V S/S CW DE FASCO MODEL 80855BRVA-A16S	
SHEET	DWG. NO.	8M855BRVA-A16S	
A3	REVISION	A	