

THIRD ANGLE PROJECTION

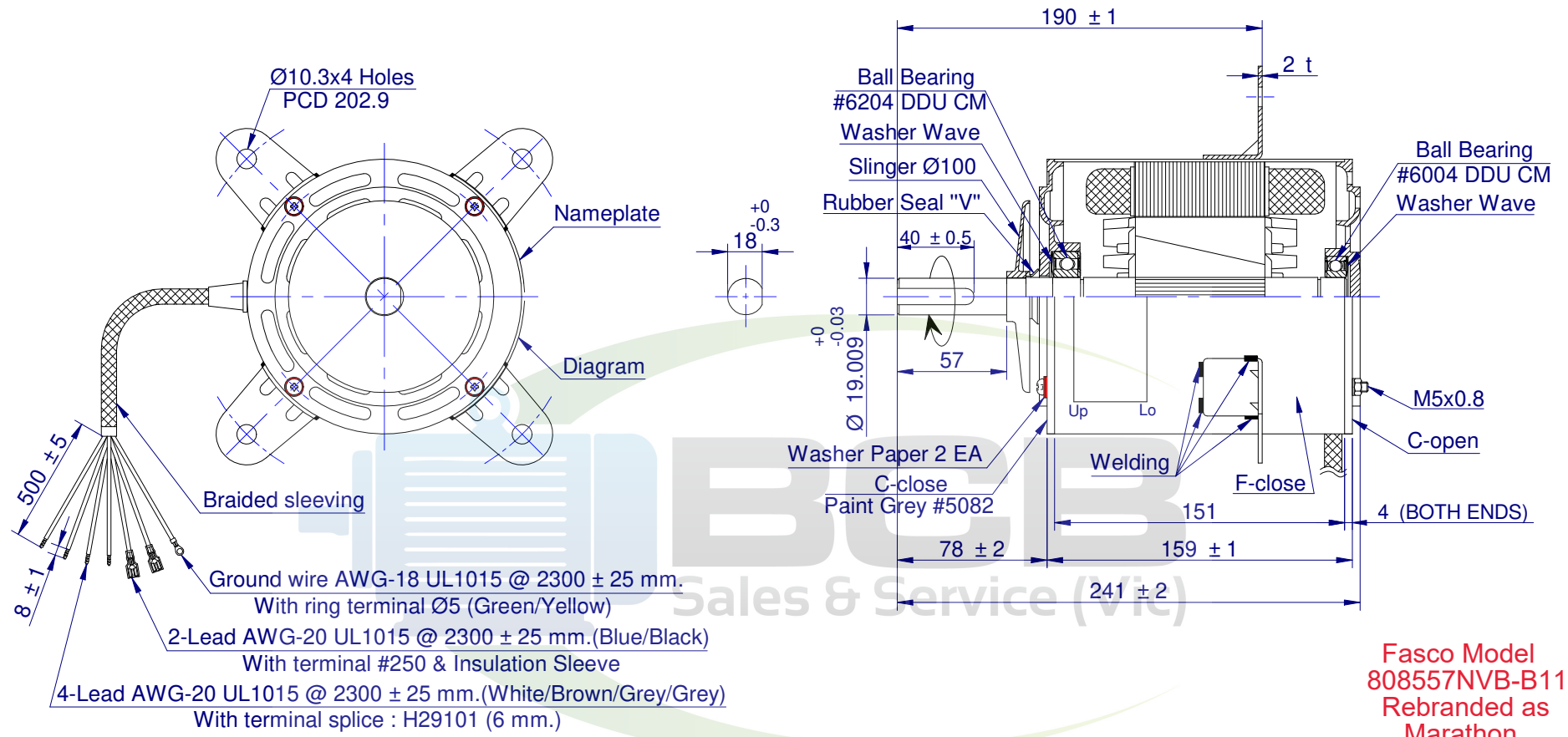

Fasco Model 808557NVB-B11 Rebranded as Marathon

marathon Motors DESIGNED AND MANUFACTURED TO AUSTRALIAN STANDARDS & SPECIFICATIONS

MODEL	8M8557NVB-B11S		
	DDMMYYXXXX		

VOLTS 240 R.P.M. 900/2SP CLASS B130 Hz 50
 WATTS 450 TYPE CSR μF/V R 20/450 Ph 1
 AMPS 3.0 DUTY S1/AOM PROT. AUTO

WARNING MOTOR FITTED WITH INTERNAL AUTO RESET OVERLOAD AND MAY RESTART WITHOUT WARNING

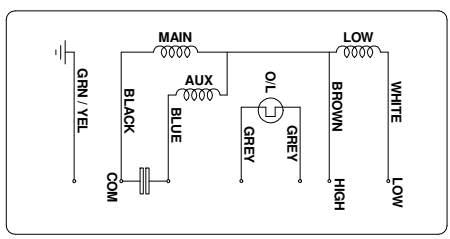

MOTOR SPECIFICATION

Q.R. NO.	QR230064	CUSTOMER PART NO.	808557NVB-B11S					
MOTOR RATING	VOLTS	240	Hz	50	PH	1	DUTY	A.O.M.
	RPM.	900/2SP		3.0		AMPS		
	NOM. OUTPUT	450 WATTS						
ROTATION	CLOCKWISE DRIVE END							
CAPACITOR	START	---	μF/V	RUN	20/450		μF/V	
MOTOR TYPE	CSR		INSULATION CLASS		B130			
THERMAL PROTECTION	AUTO RESET OVERLOAD							
DATA TEST NO.	W443-1118-SL		PAINT/ COLOUR		GREY #5082			

- SPECIAL REQUIREMENTS:**
- 1) After the motor is complete, applied rust proof oil at shaft end.
 - 2) The tensile strength of each lead wire at least 4 Kgs.
 - 3) The runout of the shaft end circumference 0.08 mm.
 - 4) Capacitor supplied by Customer.
 - 5) Motor to be packed in single carton.

UNLESS OTHERWISE SPECIFIED : DIMENSIONS ARE IN MM. TOLERANCES

DECIMALS	ANGULAR
X ± 1.0	± 30'
.XX ± 0.1	

THIS DRAWING REMAINS THE PROPERTY OF REGAL BELOIT AUSTRALIA AND MAY NOT BE USED, COPIED OR ISSUED WITHOUT WRITTEN PERMISSION FROM REGAL BELOIT AUSTRALIA

MOTOR WEIGHT	9.50	kg.
DRAWN	THANATCHA	12/09/2023
CHECKED	EKAPHOP	12/09/2023
RELEASED	WEERAPAN	12/09/2023
SCALE	N.T.S.	

BCB Sales & Service (Vic)
 sales@bcbsales.com.au
 03 9546 3833

FRAME	MOTOR		
STATUS	R	450W 6P 2SP 240V S/S CW DE FASCO MODEL 808557NVB-B11S	
SHEET	DWG. NO.		REVISION
A3	8M8557NVB-B11S		B

DOC No. ...
 By: Thanatcha
 Date: 12/09/2023
 DOC No. Change bearing at drive end from 6004 DDU CM
 Note: To be 6204 DDU CM