

THIRD ANGLE PROJECTION

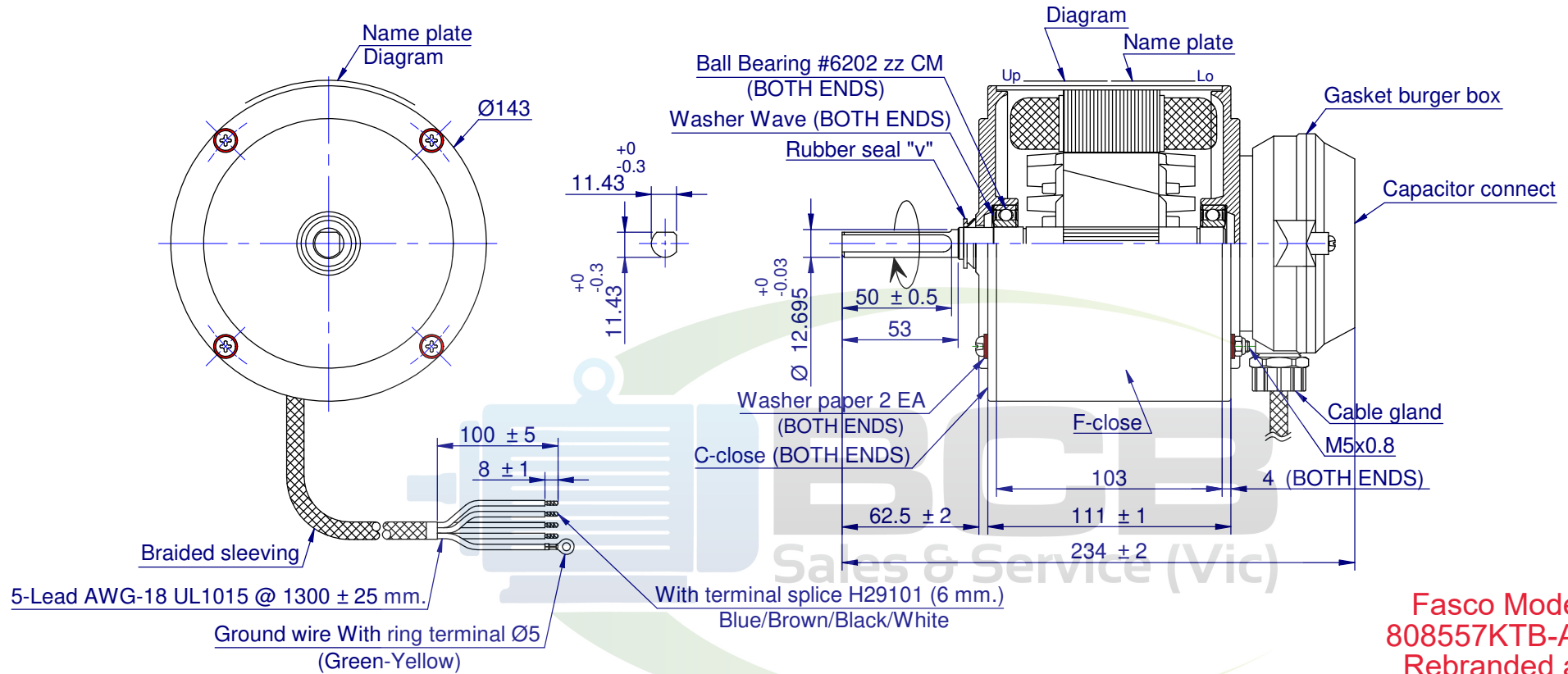

**Fasco Model 808557KTB-A11
 Rebranded as
 Marathon**

marathon Motors
 DESIGNED AND MANUFACTURED TO AUSTRALIAN STANDARDS & SPECIFICATIONS

MODEL	8M8557KTB-A11S		
	DDMMYYXXXX		

VOLTS 240 R.P.M. 900/3SP CLASS B130 Hz 50
 WATTS 150 TYPE CSR μF/V R 6/440 Ph 1
 AMPS 1.2 DUTY AOM PROT. AUTO

WARNING MOTOR FITTED WITH INTERNAL AUTO RESET OVERLOAD AND MAY RESTART WITHOUT WARNING

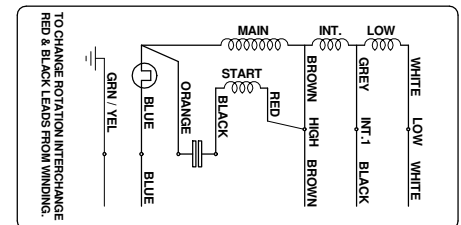

NAMEPLATE

DIAGRAM

MOTOR SPECIFICATION

Q.R. NO.	QR230046	CUSTOMER PART NO.	808557KTB-A11S		
MOTOR RATING	VOLTS	240	Hz	50	PH 1 DUTY A.O.M.
	RPM.	900/3SP			1.2 AMPS
	NOM. OUTPUT	150 WATTS			
ROTATION	CLOCKWISE DRIVE END (REVERSIBLE)				
CAPACITOR	START	---	μF/V	RUN	6/440 μF/V
MOTOR TYPE	CSR	INSULATION CLASS		B130	
THERMAL PROTECTION	AUTO RESET OVERLOAD				
DATA TEST NO.	W443-2911-SL	PAINT/ COLOUR	GREY #5082		

- SPECIAL REQUIREMENTS:**
- 1) After the motor is complete, applied rust proof oil at shaft end.
 - 2) The tensile strength of each lead wire at least 4 Kgs.
 - 3) The runout of the shaft end circumference 0.08 mm.
 - 4) Default : rotation clockwise at drive end.
 - 5) Motor to be packed in single carton.

UNLESS OTHERWISE SPECIFIED : DIMENSIONS ARE IN MM. TOLERANCES

DECIMALS	ANGULAR
.X ± 1.0	± 30'
.XX ± 0.1	

MOTOR WEIGHT: 6.19 kg.

DRAWN	THANATCHA	14/08/2023
CHECKED	EKAPHOP	14/08/2023
RELEASED	WEERAPAN	14/08/2023
SCALE	N.T.S.	

THIS DRAWING REMAINS THE PROPERTY OF REGAL BELOIT AUSTRALIA AND MAY NOT BE USED, COPIED OR ISSUED WITHOUT WRITTEN PERMISSION FROM REGAL BELOIT AUSTRALIA

BCB
 Sales & Service (Vic)
 sales@bcbsales.com.au
 03 9546 3833

FRAME	MOTOR		
STATUS	150W 6P 3SP 240V S/S REV		
	FASCO MODEL 808557KTB-A11S		
SHEET	DWG. NO.	REVISION	
A3	8M8557KTB-A11S	A	

DOC No. _____
 Date: _____
 DOC No. _____