

THIRD ANGLE PROJECTION

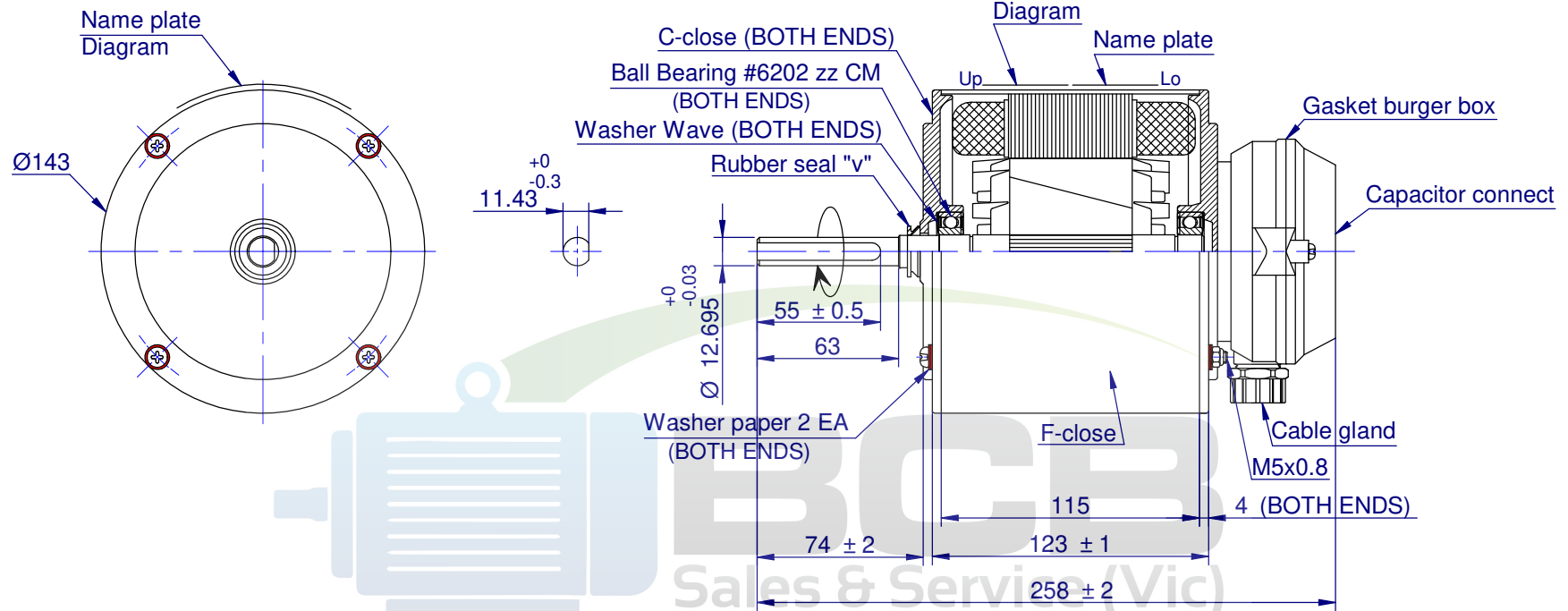

Fasco Model  
 8061S137-80  
 Rebranded as  
 Marathon

**marathon** Motors DESIGNED AND MANUFACTURED TO AUSTRALIAN STANDARDS & SPECIFICATIONS

MODEL	8M61S137-80S
	DDMMYYXXXX

VOLTS 240 R.P.M. 910 CLASS B130 Hz 50  
 WATTS 250 TYPE CSR µF/V R 4/440 Ph 1  
 AMPS 2.3 DUTY AOM PROT. AUTO

**WARNING** MOTOR FITTED WITH INTERNAL AUTO RESET OVERLOAD AND MAY RESTART WITHOUT WARNING

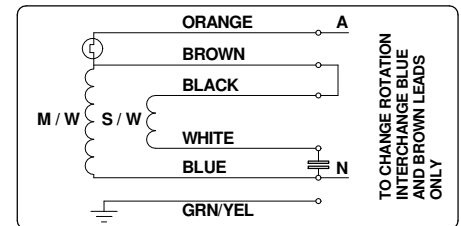

MOTOR SPECIFICATION									
Q.R. NO.	QR230054			CUSTOMER PART NO.	8061S137-80S				
MOTOR RATING	VOLTS	240	Hz	50	PH	1	DUTY	A.O.M.	
	RPM.	910				2.3		AMPS	
	NOM. OUTPUT	250 WATTS							
ROTATION	CLOCKWISE DRIVE END (REVERSIBLE)								
CAPACITOR	START	---	µF/V	RUN	4/440		µF/V		
MOTOR TYPE	CSR		INSULATION CLASS			B130			
THERMAL PROTECTION	AUTO RESET OVERLOAD								
DATA TEST NO.	W443-1570-SL		PAINT/COLOUR	GREY #5082					

- SPECIAL REQUIREMENTS:**
- 1) After the motor is complete, applied rust proof oil at shaft end.
  - 2) The tensile strength of each lead wire at least 4 Kgs.
  - 3) The runout of the shaft end circumference 0.08 mm.
  - 4) Default : rotation clockwise at drive end.
  - 5) Motor to be packed in single carton.

UNLESS OTHERWISE SPECIFIED : DIMENSIONS ARE IN MM. TOLERANCES			MOTOR WEIGHT		
			7.50 kg.		
DECIMALS	ANGULAR		DRAWN	THANATCHA	05/08/2023
X ± 1.0	± 30'		CHECKED	EKAPHOP	05/08/2023
.XX ± 0.1			RELEASED	WEERAPAN	05/08/2023
THIS DRAWING REMAINS THE PROPERTY OF REGAL BELOIT AUSTRALIA AND MAY NOT BE USED, COPIED OR ISSUED WITHOUT WRITTEN PERMISSION FROM REGAL BELOIT AUSTRALIA			SCALE	N.T.S.	

**BCB**  
 Sales & Service (Vic)  
 sales@bcbsales.com.au  
 03 9546 3833

FRAME	MOTOR		
STATUS	250W 6P 1SP 240V S/S REV		
SHEET	FASCO MODEL 8061S137-80S		REVISION
A3	8M61S137-80S		A

DOC No. \_\_\_\_\_  
 Date: \_\_\_\_\_  
 DOC No. \_\_\_\_\_