

THIRD ANGLE PROJECTION

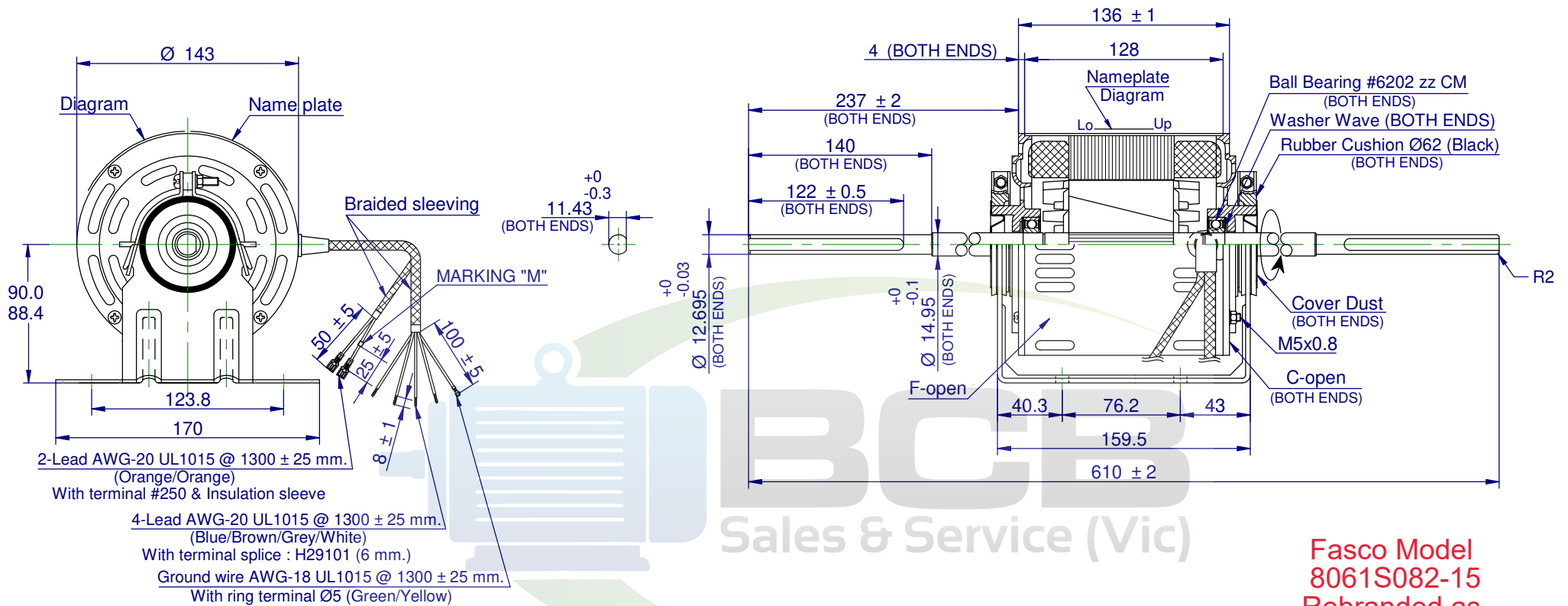

**Fasco Model 8061S082-15
 Rebranded as Marathon**

DOC No. ...
 By: Thanatcha
 Date: 13/01/2023
 DOC No. ...
 Note: Change length of the leads from 1m to be 1.3m

MOTOR SPECIFICATION

Q.R. NO.	---		CUSTOMER PART NO.	8061S082-15	
MOTOR RATING	VOLTS	240	Hz	50	PH 1
	RPM.	1330/3SP		4.0 AMPS	
	NOM. OUTPUT	600 WATTS			
ROTATION	ANTI CLOCKWISE AT LEAD END				
CAPACITOR	START	---	μ F/V	RUN	15/440 μ F/V
MOTOR TYPE	CSR		INSULATION CLASS		B130
THERMAL PROTECTION	AUTO RESET OVERLOAD				
DATA TEST NO.	W443-2847-SL		PAINT/ COLOUR	GREY #5082	

SPECIAL REQUIREMENTS:

- 1) After the motor is complete, applied rust proof oil at shaft end.
- 2) The tensile strength of each lead wire at least 4 Kgs.
- 3) The runout of the shaft end circumference 0.20 mm.

UNLESS OTHERWISE SPECIFIED : DIMENSIONS ARE IN MM. TOLERANCES
 DECIMALS ANGULAR
 X \pm 1.0 \pm 30'
 .XX \pm 0.1

THIS DRAWING REMAINS THE PROPERTY OF REGAL BELOIT AUSTRALIA AND MAY NOT BE USED, COPIED OR ISSUED WITHOUT WRITTEN PERMISSION FROM REGAL BELOIT AUSTRALIA

MOTOR WEIGHT		
10.49 kg.		
DRAWN	THANATCHA	13/01/2023
CHECKED	EKAPHOP	13/01/2023
RELEASED	WEERAPAN	13/01/2023
SCALE	N.T.S.	

BCB
Sales & Service (Vic)
 sales@bcbsales.com.au
 03 9546 3833

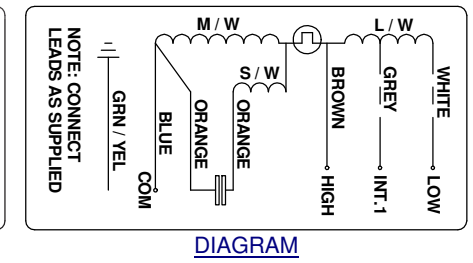

marathon Motors DESIGNED AND MANUFACTURED TO AUSTRALIAN STANDARDS & SPECIFICATIONS

MODEL	8M61S082-15		
	DDMMYYXXXX		

VOLTS 240 R.P.M. 1330/3SP CLASS B130 Hz 50
 WATTS 600 TYPE CSR μ F/V R 15/440 Ph 1
 AMPS 4.0 DUTY AOM PROT. AUTO

WARNING MOTOR FITTED WITH INTERNAL AUTO RESET OVERLOAD AND MAY RESTART WITHOUT WARNING

NAMEPLATE

FRAME	MOTOR		
STATUS	R		
SHEET	DWG. NO.		
A3	8M61S082-15		REVISION
			B