

THIRD ANGLE PROJECTION

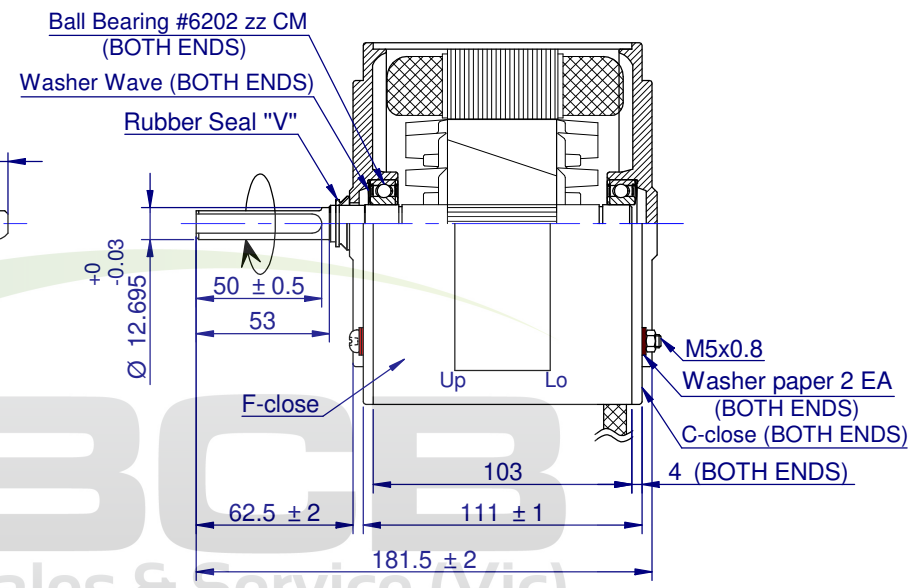
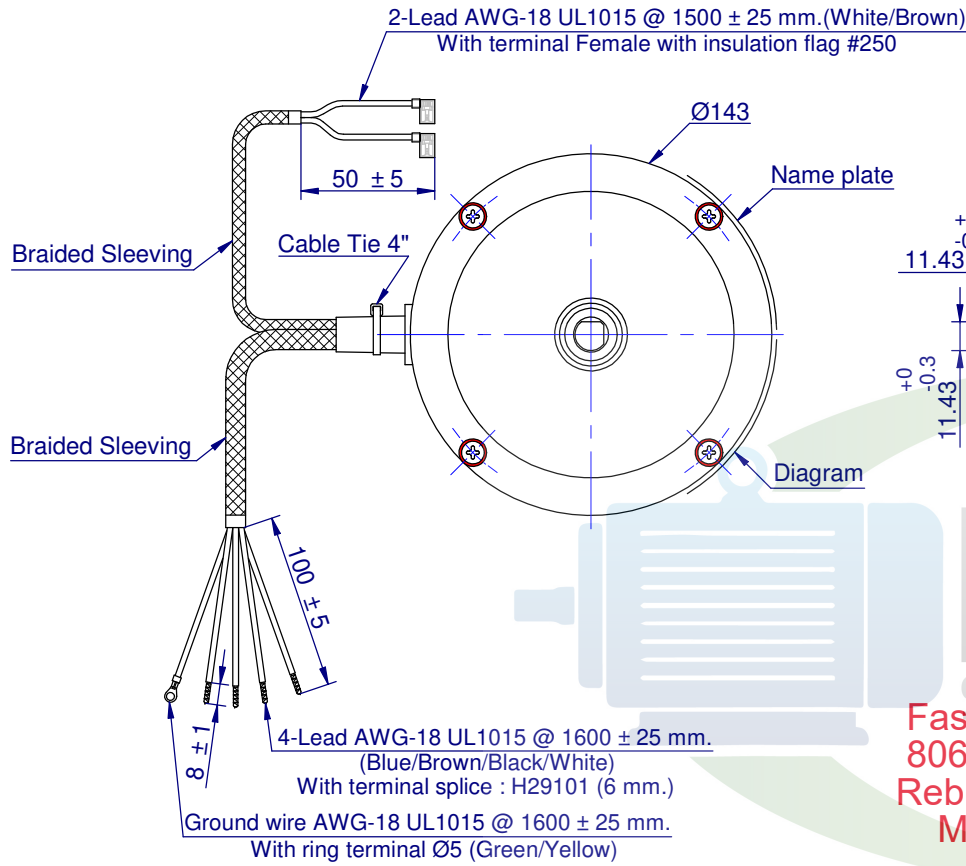

Fasco Model 8061S059-04
Rebranded as Marathon

marathon Motors DESIGNED AND MANUFACTURED TO AUSTRALIAN STANDARDS & SPECIFICATIONS

MODEL	8M61S059-04S		
	DDMMYYXXXX		

VOLTS 240 R.P.M. 900/3SP CLASS B130 Hz 50
 WATTS 150 TYPE CSR μF/V R 6/450 Ph 1
 AMPS 1.2 DUTY AOM PROT. AUTO

WARNING MOTOR FITTED WITH INTERNAL AUTO RESET OVERLOAD AND MAY RESTART WITHOUT WARNING

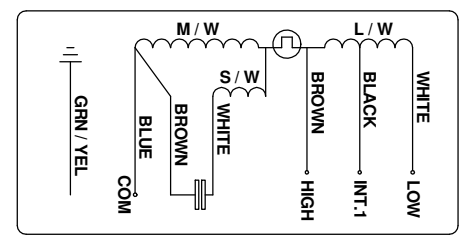

NAMEPLATE

DIAGRAM

MOTOR SPECIFICATION

Q.R. NO.	QR230049	CUSTOMER PART NO.	8061S059-04S		
MOTOR RATING	VOLTS	240	Hz	50	PH 1 DUTY A.O.M.
	RPM.	900/3SP			1.2 AMPS
	NOM. OUTPUT	150 WATTS			
ROTATION	CLOCK WISE AT DRIVE END				
CAPACITOR	START	---	μF/V	RUN	6/450 μF/V
MOTOR TYPE	CSR	INSULATION CLASS		B130	
THERMAL PROTECTION	AUTO RESET OVERLOAD				
DATA TEST NO.	W443-2870-SL	PAINT/ COLOUR	GREY #5082		

SPECIAL REQUIREMENTS:

- 1) After the motor is complete, applied rust proof oil at shaft end.
- 2) The tensile strength of each lead wire at least 4 Kgs.
- 3) The runout of the shaft end circumference 0.08 mm.
- 4) Capacitor supplied loose with motor.
- 5) Motor to be packed in single carton.

UNLESS OTHERWISE SPECIFIED : DIMENSIONS ARE IN MM. TOLERANCES		MOTOR WEIGHT	---
DECIMALS	ANGULAR		kg.
X ± 1.0	± 30'	DRAWN	THANATCHA 06/05/2023
.XX ± 0.1		CHECKED	EKAPHOP 06/05/2023
THIS DRAWING REMAINS THE PROPERTY OF REGAL BELOIT AUSTRALIA AND MAY NOT BE USED, COPIED OR ISSUED WITHOUT WRITTEN PERMISSION FROM REGAL BELOIT AUSTRALIA		RELEASED	WEERAPAN 06/05/2023
		SCALE	N.T.S.

BCB
Sales & Service (Vic)
sales@bcbsales.com.au
03 9546 3833

FRAME	MOTOR		
STATUS	R	150W 6P 3SP 240V S/S CW DE FASCO MODEL 8061S059-04S	
SHEET	DWG. NO.	8M61S059-04S	REVISION
A3			A

DOC No. / Date / Rev / DOC No. / Note