

THIRD ANGLE PROJECTION

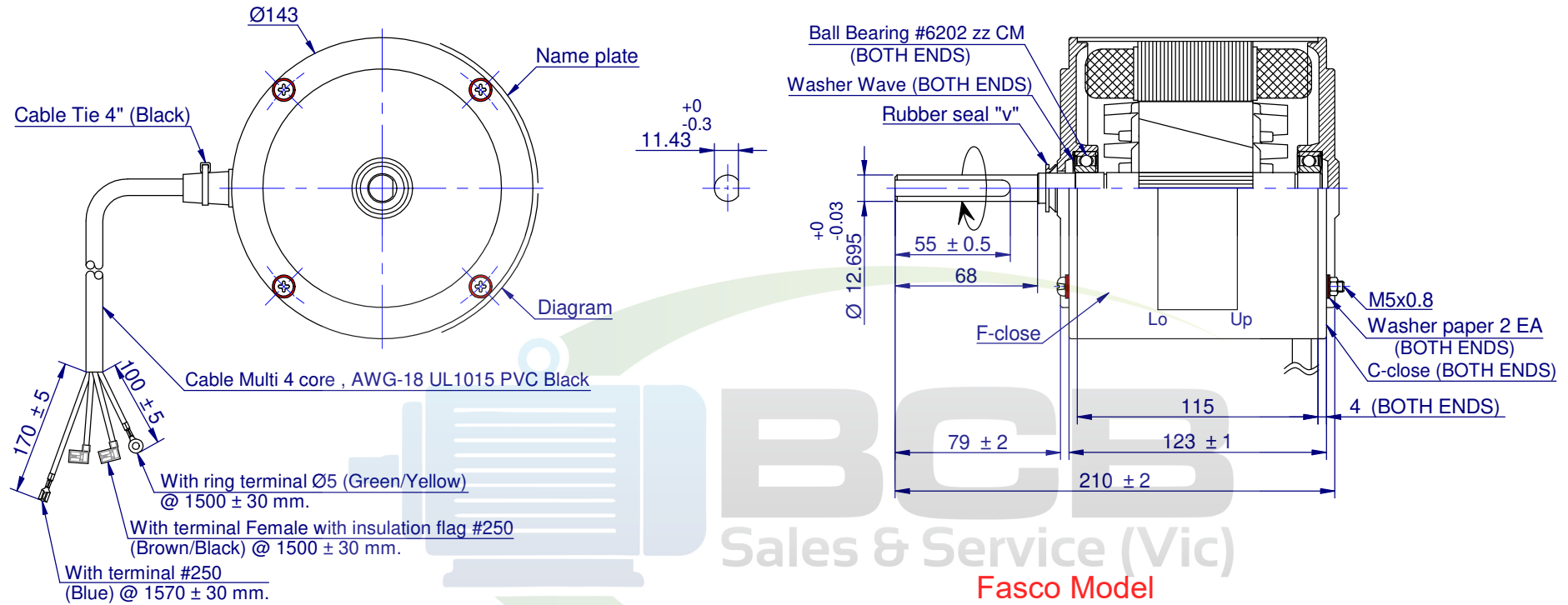

BCB
 Sales & Service (Vic)

**Fasco Model
 8061S009-06
 Rebranded as
 Marathon**

DOC No.
 By:
 Date:
 DOC No.
 Note:

MOTOR SPECIFICATION									
Q.R. NO.	QR230024		CUSTOMER PART NO.		8061S009-06S				
MOTOR RATING	VOLTS	240	Hz	50	PH	1	DUTY	A.O.M.	
	RPM.	915					2.6	AMPS	
	NOM. OUTPUT	250 WATTS							
ROTATION	CLOCK WISE AT DRIVE END								
CAPACITOR	START	---	μF/V	RUN	6/440		μF/V		
MOTOR TYPE	CSR		INSULATION CLASS		B130				
THERMAL PROTECTION	AUTO RESET OVERLOAD								
DATA TEST NO.	W443-2863-SL		PAIN/ COLOUR	GREY #5082					

- SPECIAL REQUIREMENTS:**
- 1) After the motor is complete, applied rust proof oil at shaft end.
 - 2) The tensile strength of each lead wire at least 4 Kgs.
 - 3) The runout of the shaft end circumference 0.08 mm.
 - 4) Motor to be packed in single carton.

marathon Motors				DESIGNED AND MANUFACTURED TO AUSTRALIAN STANDARDS & SPECIFICATIONS			
MODEL		8M61S009-06S		DDMMYYXXXX			
VOLTS 240	R.P.M. 915	CLASS B130	Hz 50				
WATTS 250	TYPE CSR	μF/V R 6/440	Ph 1				
AMPS 2.6	DUTY AOM	PROT. AUTO					
WARNING				MOTOR FITTED WITH INTERNAL AUTO RESET OVERLOAD AND MAY RESTART WITHOUT WARNING			

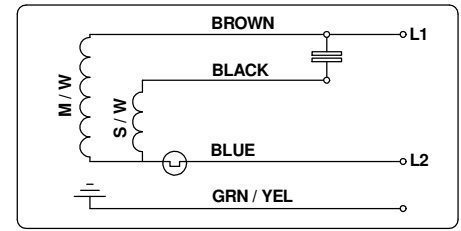

UNLESS OTHERWISE SPECIFIED : DIMENSIONS ARE IN MM. TOLERANCES			MOTOR WEIGHT		
			7.25 kg.		
DECIMALS	ANGULAR		DRAWN	THANATCHA	21/04/2023
.X ± 1.0	± 30'		CHECKED	EKAPHOP	21/04/2023
.XX ± 0.1			RELEASED	WEERAPAN	21/04/2023
THIS DRAWING REMAINS THE PROPERTY OF REGAL BELOIT AUSTRALIA AND MAY NOT BE USED, COPIED OR ISSUED WITHOUT WRITTEN PERMISSION FROM REGAL BELOIT AUSTRALIA			SCALE	N.T.S.	

BCB
 Sales & Service(Vic)
 sales@bcbsales.com.au
 03 9546 3833

FRAME	MOTOR		
STATUS	250W 6P 1SP 240V S/S CW DE		
SHEET	FASCO MODEL 8061S009-06S		
A3	DWG. NO.	REVISION	
	8M61S009-06S	A	