

FASCO MOTORS MAY PROVIDE TECHNICAL ASSISTANCE TO CUSTOMERS IN MANY AREAS. HOWEVER, SINCE FASCO MOTOR IS THE PROPERTY OF ALL DATA CONCERNING THE USE AND APPLICATION OF THIS MOTOR, THE FITNESS OF THE MOTOR FOR THE APPLICATION MUST BE DETERMINED BY AND IS THE RESPONSIBILITY OF THE CUSTOMER.

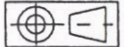

THIRD ANGLE PROJECTION

MOTOR SPECIFICATION

808536MTB-A11

Q.R. No.	Y001045	CUSTOMER NO.	-
CUSTOMER	VARIOUS		
MOTOR RATING	VOLTS	415	Hz 50 Ph 3 Duty A.O.M.
	RPM.	900	0.95 AMPS
	NOM. OUTPUT	250 WATTS	
ROTATION	CLOCKWISE DRIVE END (REVERSIBLE)		
CAPACITOR	START	-----	μF/V RUN - μF/V
ENCLOSURE	TOTALLY ENCLOSED		
MOTOR TYPE	3 PH	INSULATION CLASS	B130
THERMAL PROTECTION	NIL		
APPLICATION	FAN		
BEARING D.E.	6202 DDU C3 EA2	LUBRICATION	LONG LIFE, WIDE RANGE
BEARING N.D.E.	6202 DDU C3 EA2		
SUPPLY LEAD	-		
EARTH PROVISION	IN TERM. BOX		
BASIC BUILD SPECIFICATION	305-570-05	PAINT/ COLOUR	PC GREY CASE PLAIN E/SH
PERFORMANCE SPECIFICATION	SP85105-01		
CONNECTION DIAGRAM	393-000-AM	RATING LABEL	LABELSTD.FMT

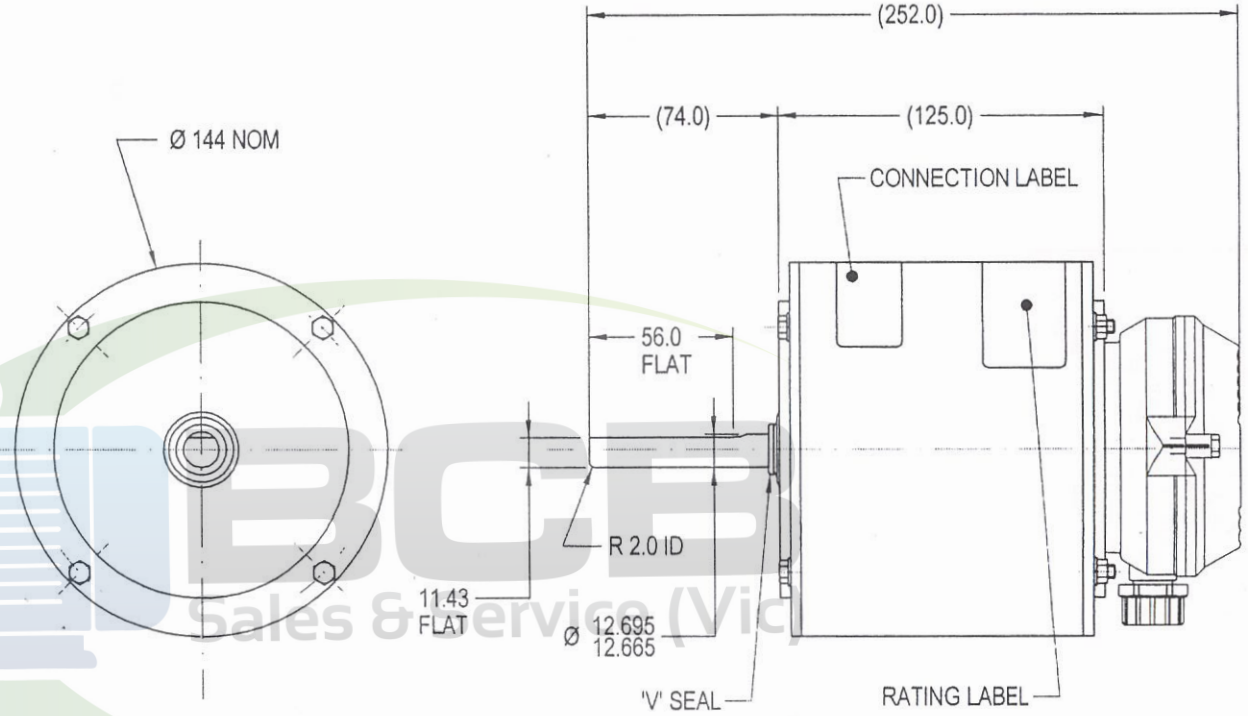

FASCO DESIGNED AND MANUFACTURED TO AUSTRALIAN STANDARDS & SPECIFICATIONS

C N693 MODEL **808536MTB-A11**

VOLTS	415	TYPE	3 PHASE	Hz	50
WATTS	250	DUTY	AOM	PH	3
AMPS	0.95	CLASS	B130	PROT.	NIL
R.P.M.	900	uF/V	S NIL	R	NIL
WATTS IN MAX		MAX kPa			

SPECIAL REQUIREMENTS:

- WEATHER PROOF SPEC. BEI 176.
- CONNECTION LABEL 393-487-01 TO BE PUT ON CASE.

UNLESS OTHERWISE SPECIFIED : DIMENSIONS ARE IN MM. TOLERANCES

DECIMALS	ANGULAR
.X ± 1.0	± 30'
.XX ± 0.5	

THIS DRAWING REMAINS THE PROPERTY OF FASCO MOTORS AND MAY NOT BE USED, COPIED OR ISSUED WITHOUT WRITTEN PERMISSION FROM FASCO MOTORS

BCB SALES & SERVICE

PH : 03 9546 3833
FAX : 03 9546 3356

MATL & FINISH	FRAME
DRAWN NUTAPONG	STATUS R
CHECKED KITTI	SHEET
RELEASED KITTI	DWG. NO.
SCALE	A3

24/02/01
DISTRIBUTION, MUANG NONGTHABURI DISTRICT, NONTHABURI 11000 THAILAND

MOTOR

105:8536T-250-XCH

DWG. NO. **808536MTB-A11**

REVISION **A**

CONTROLLED COPY
18 AUG 2001

MIC No. 003841
 BY: NUTAPONG
 Date: 24/02/01
 MIC MODEL RELEASED AT FMTL RE-INSTATED

Replaces 61524-80