

ORACLE PART REV. 013

THERMALLY PROTECTED  
CLASS "B" INSULATION  
416 S.S. SHAFT

APPLICATION:	B	LA	FR	A	S	C	E	B	A
CUSTOMER:	06	21	30	V	02	FF	5	3	6
CUSTOMER PN:	5-2810-005-035								

- NOTES:
- LOCATION OF IMPELLER TO BE .164(.084 [4,168/2,134]) FROM EDGE OF IMPELLER TO INSIDE OF HOUSING SHELL.
  - PACK 6 PER CONTAINER, 4 CONTAINERS PER LAYER, 5 LAYERS PER PALLET, 120 MAX. PER PALLET, PACKING ASSY.: 87654355, P.S. 88634200 & P.S. 88634408.
  - FOR PALLET LAYOUT SEE 87654929.
  - PALLET MUST BE BANDED (4) PLACES, THEN STRETCH WRAPPED.

CORDSET MATERIAL  
18 GA, 105°C SJT  
3-COND, BLK JACKET  
(1) BLU (1) BRN (1) GRN/YEL  
27.50/25.50 IN. [698,50/647,70] [mm] LONG  
2.25/1.75 IN. [57,15/44,45] [mm] RIP  
.44/.32 IN. [11,18/8,128] [mm] STRIP

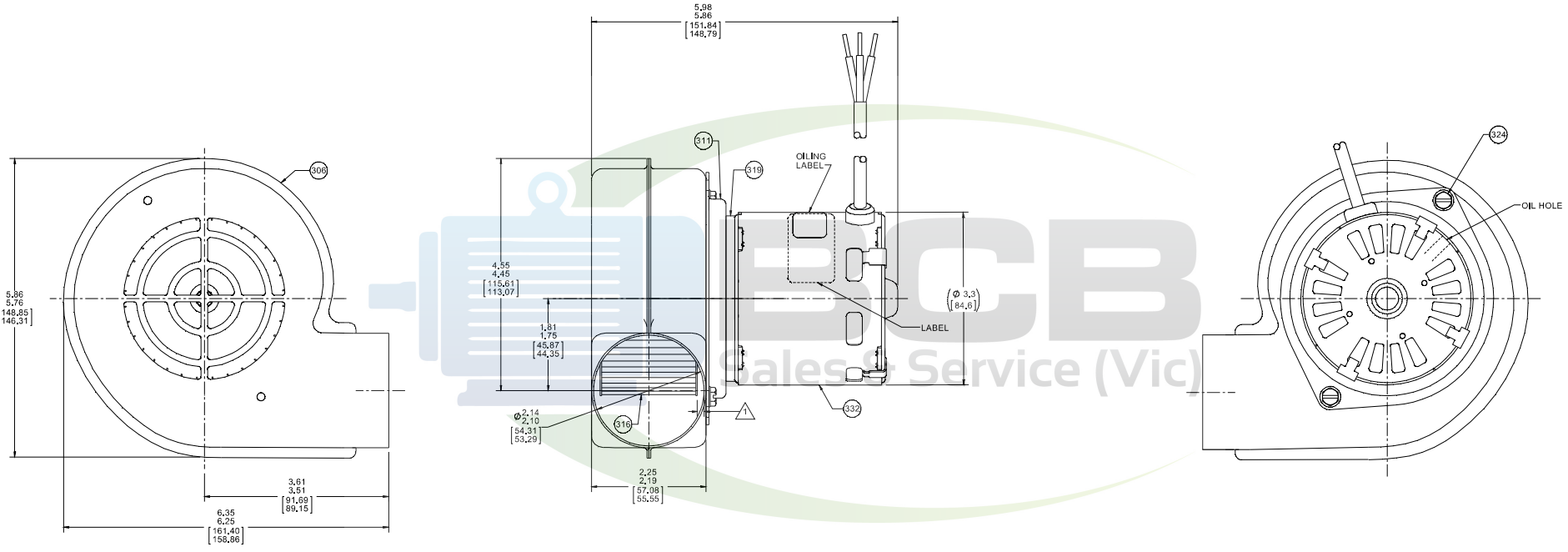

TYPICAL PERFORMANCE TEST DATA IN FREE AIR

AT 240 VOLTS 50 Hz			
	RPM	WATTS	AMPS
	2770	64	.43
BLOWER WEIGHT	ENDPLAY		
3.75 LBS.	.036/.010 [889/254]		

DRAWING REVISION P	APPROVED BY JMG	DATE 4/22/2015	REGAL BELT'S ONLY USE OTHERS SPECIFIED	DRAWN BY JMG	DATE 4/22/2015	REGAL BELT AMERICA, INC.
ECO-0072430	APPROVED BY JMG	DATE 4/22/2015	XXXX 450000 [15,127]	APPROVED BY JMG	DATE 4/22/2015	DESCRIPTION BLOWER ASSY
REGISTRATION: UPDATED PACKING, REDRAWN ON SW			REMOVE BURRS & BREAK SHARP EDGES - .00125 DIA. CORNER R	REFERENCE	DATE	PROCESSOR: BEAC
PROMPTLY CONTACT REGAL BELT AMERICA, INC. IF YOU HAVE ANY QUESTIONS REGARDING THIS DRAWING. TO ORDER, PLEASE CONTACT REGAL BELT AMERICA, INC. AT 1-800-828-8888. REGAL BELT AMERICA, INC. IS NOT RESPONSIBLE FOR ANY DAMAGE TO PROPERTY OR PERSONS RESULTING FROM THE USE OF THIS DRAWING. REGAL BELT AMERICA, INC. IS NOT RESPONSIBLE FOR ANY DAMAGE TO PROPERTY OR PERSONS RESULTING FROM THE USE OF THIS DRAWING.			CORNER RADIUS: RCH ✓	DATE	DESCRIPTION NUMBER	70219938
REGAL BELT AMERICA, INC. 10000 REGAL BLVD. REGAL, OHIO 44079-1000			FINISH: RAUGH	DATE	DESCRIPTION NUMBER	70219938
REGAL BELT AMERICA, INC. 10000 REGAL BLVD. REGAL, OHIO 44079-1000			FINISH: RAUGH	DATE	DESCRIPTION NUMBER	70219938