

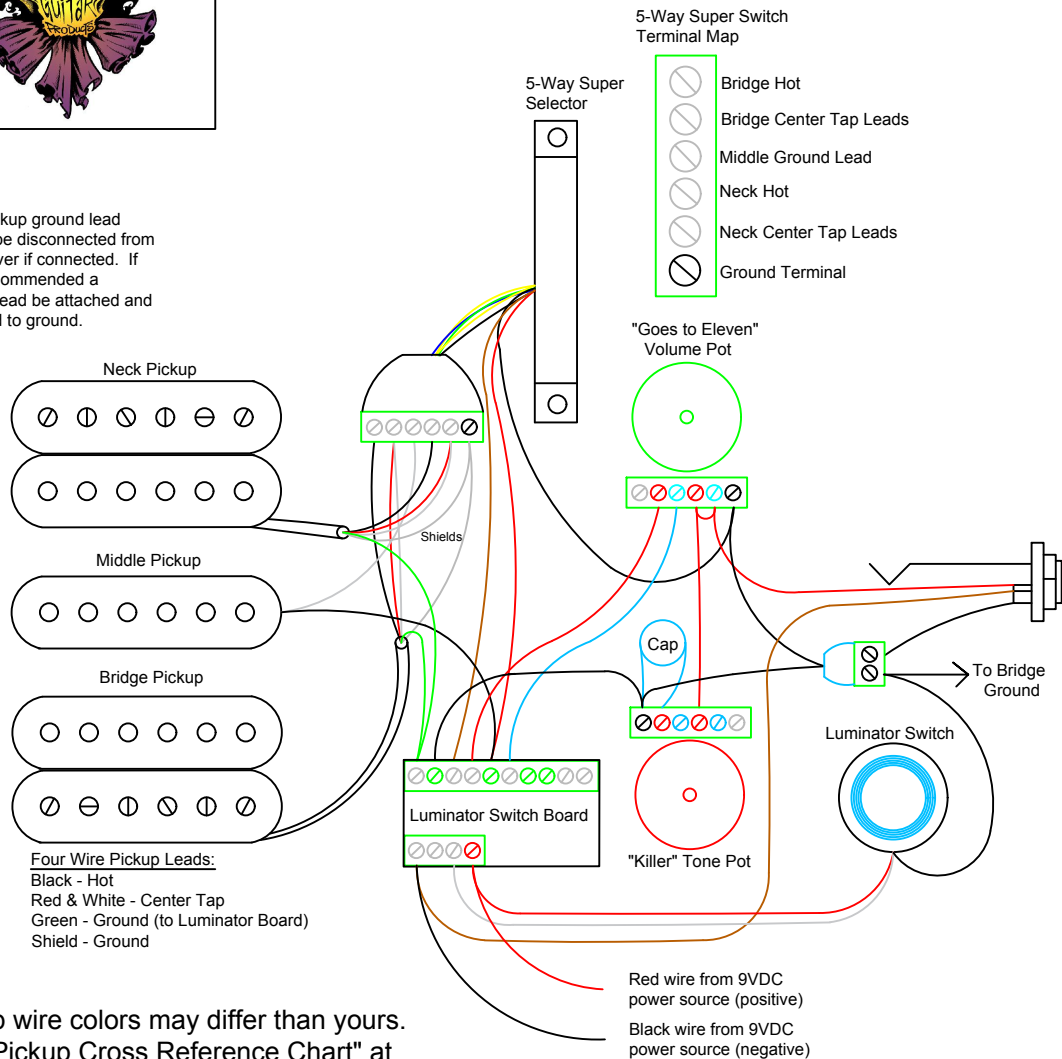

Luminator TEN

Middle pickup ground lead needs to be disconnected from pickup cover if connected. If so, it's recommended a separate lead be attached and connected to ground.



Pickup wire colors may differ than yours. See "Pickup Cross Reference Chart" at madhatterguitarproducts.com to verify your pickup wire color configuration.

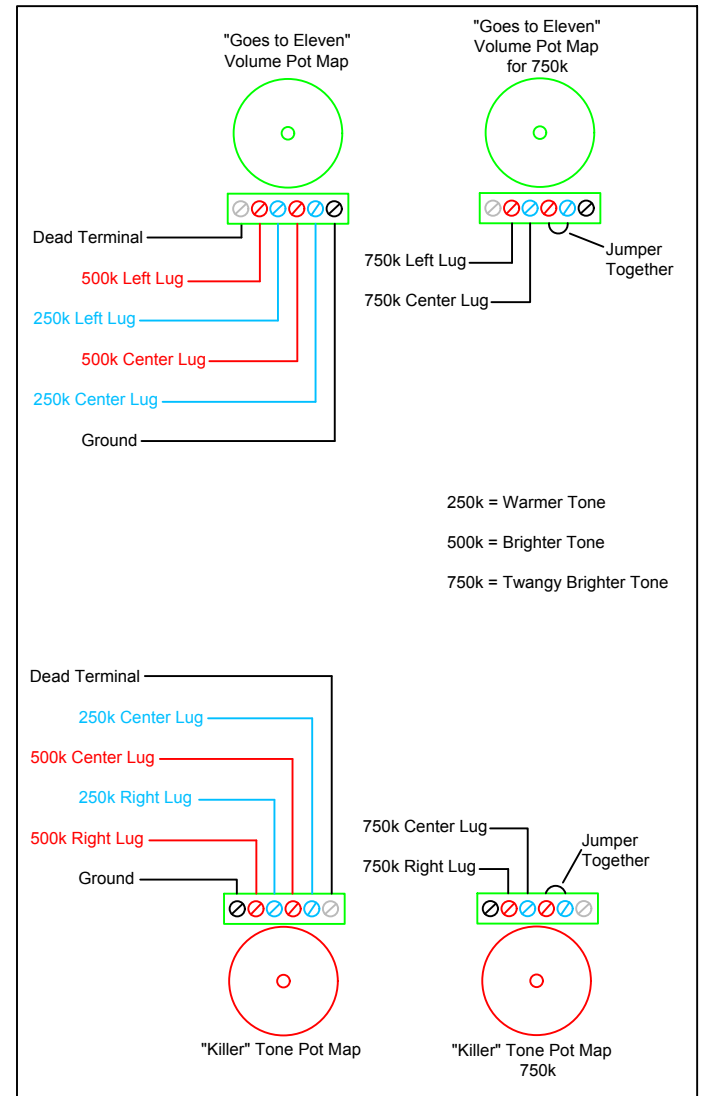

Ground Terminals (black):

- All components must be interconnected with a ground wire
- Avoid placing more than three wires per Ground Terminal
- Pickup shields and ground wires can be placed on any Ground Terminal
- Dead Terminals can be utilized as an additional ground wire landing point by placing a jumper from a Ground Terminal to the Dead Terminal

Customer Support:
info@madhatterguitarproducts.com

The Terminator is Patent Pending

Installation Instructions

Getting Started:

1. Determine where to mount the Luminator Touch Capacitance Switch. The switch requires a 5/8" (15.9mm) clearance hole that is no more than a 1/2" (12.7mm) thick.
2. Be sure the location will not impede any of the other components and all non-shielded signal wires will be at least a 1/4" away from switch to avoid unwanted noise.
3. Determine if there is enough space within the control cavity for the Luminator Switch Board. The Luminator Switch Board is 1 1/2" (38.1mm) x 1" (25.4mm) x 1/2" (12.7mm). The Luminator Switch Board can be Velcro attached to the Luminator Touch Capacitance Switch, or another solid surface. It's very important that the Power Input – Switch Terminal is free and clear of other components to avoid shorting.
4. The Luminator System requires a 9V power supply.
 - If using a standard 9V battery, test fit cavity locations for simple installations, or consider installing an external accessible battery compartment (available separately.) It is very important the battery is not allowed to short contacts between controls in the instrument.

4. Cont.

- If using a separate rechargeable battery, refer to those instructions to complete this part of the installation.
- The Luminator System works best with its own independent power source. It may not work well when sharing a 9V power supply with other components such as active pickups.
- Only switch the negative (black) lead of the power source to apply power to the Luminator System.

5. System Operation

- 7.5-9.5VDC Operating Voltage
- -10°C to 65°C Operating Temperature
- In Blue Mode only the blue light is being powered by the battery.
- In Red Mode the Luminator Switch Board is active. When activated the LDO Regulator on the Luminator Switch Board will become hot to the touch. This is normal.
- In Red Mode battery consumption is much greater. Continual operation in Red Mode only is less than an hour.
- The Red light will dim when battery is low, but guitar operation will continue.

Installation Warning!

By self-installing and/or misusing this product, you understand and agree that and such uses are high risk activities and, to the extent permitted by law, YOU EXPRESSLY AND VOLUNTARITLY ASSUME THE RISK OF DEATH OR OTHER PERSONAL INJURY SUSTAINED WHILE PARTICIPATING IN SUCH ACTIVITIES WHETHER OR NOT CAUSED BY THE NEGLIGENCE OR ANY OTHER FAULT of Mad Hatter Guitar Products and its parent company Goes to Eleven, Inc., including but not limited to equipment malfunction from whatever cause, or any other fault of Mad Hatter Guitar Products and its parent company Goes to Eleven, Inc. Additionally, you agree to indemnify, defend, and hold Mad Hatter Guitar Products and its parent company Goes to Eleven, Inc. harmless from third party claims arising from such activities.

Luminator

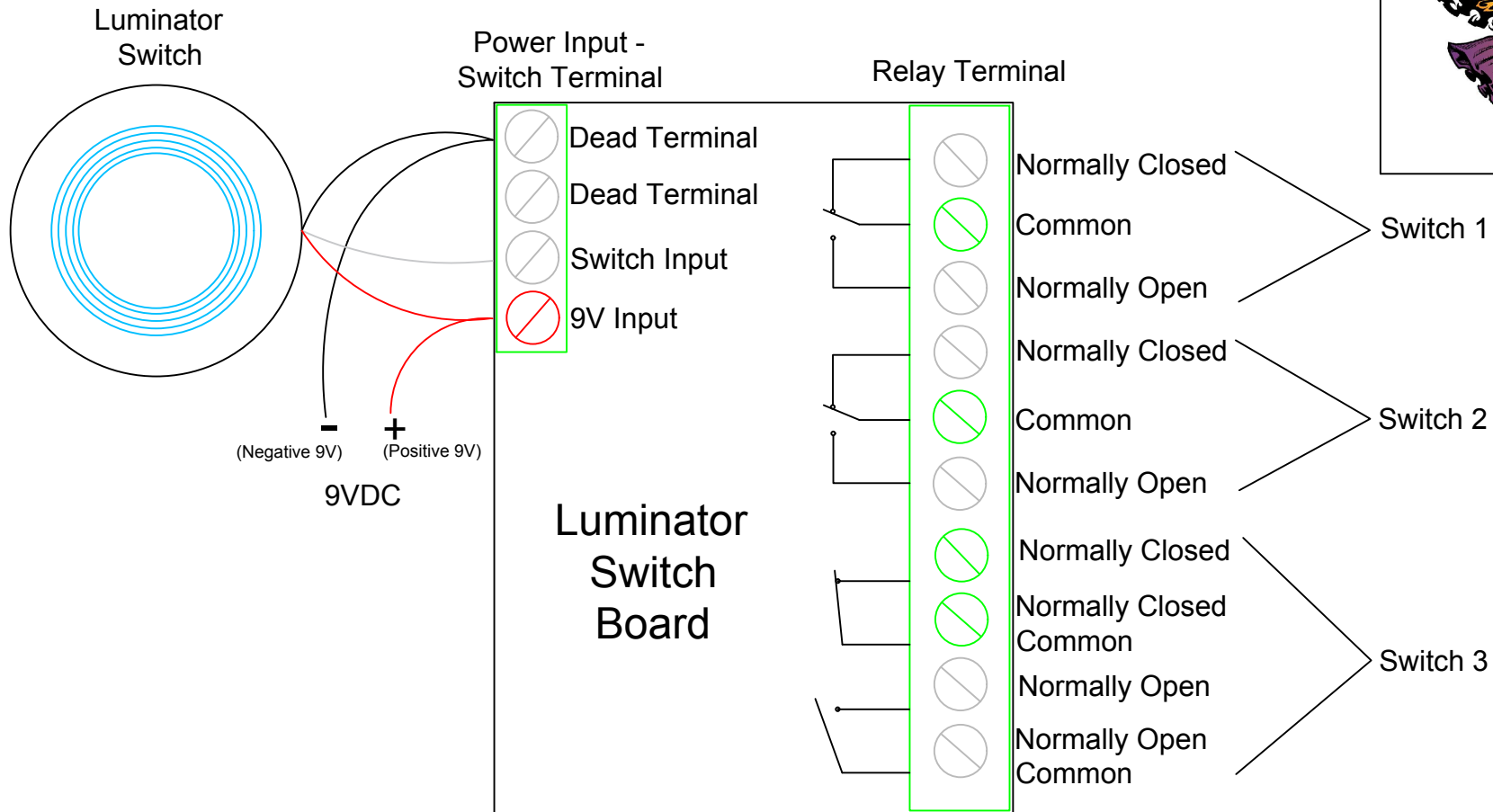

IMPORTANT!!! Read Installation Instructions Prior to Installing.

The Luminator is Patent Pending

Customer Support:
info@madhatterguitarproducts.com

Please watch our Installation Videos!!!

Beware of tight fitting knobs!

Forcing a 6mm metric knob with a course 18 tooth knurl onto our pots will damage them. Our pots have a ¼" 24 tooth fine knurl **brass** shaft. (Terminator EVO volume and certain P/P Pots do have a 6mm shaft. They have aluminum shafts.)



You can enlarge the inside diameter of your metric knob to better fit a standard ¼" diameter shaft by using a 7/32" drill bit. By hand carefully twist the 7/32" drill bit into your knob. This will slightly open up the inside diameter.



Set screw style knobs work great with our pots. To install place the screw of the knob over the gap on the spline shaft and tighten screw into gap.

When installing selector switches make sure the following sides (metal/spring) are facing down when holding your instrument. This will ensure correct operation.

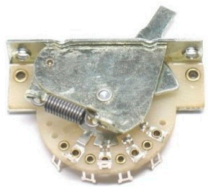

CRL



OakGrigsy

Basic Installation Instructions:

- Carefully remove all components being replaced by the Terminator
- Cut solder off remaining wires, grounds and pickup wires, and strip wires back approximately 1/8"
- Using painter's tape, tape wires to the guitar body away from the control cavity
- Carefully install Mad Hatter components into guitar. For small control cavities, wire components outside of control cavity and install in guitar after wiring
- Tape wires related to the Mad Hatter components away from the control cavity
- Determine your desired value of each Potentiometer and note where to attach wires
- Following the wiring instructions, attach needed wires between Mad Hatter components using wire provided with Kit. All components need to be connected together with a black ground wire
- **Attached pickup, bridge, output jack and all other ground wires to ANY of the ground lugs.** If needed you can also utilize one of the unused Dead Terminals with a jumper wire from a ground terminal if more ground connection points are needed
- Attach Red wire from Output Jack as per instructions
- Individually attach each pickup as per instructions
- Attach desired tone cap to tone pot, Blue leads = .022uf, Black leads = .047uf.
- Ensure all wires are properly attached and no stray wires touching other components
- Test to ensure everything is operating correctly
- Route wires within control cavity and close up

*****Note - Only use the Little Ass Screwdriver provided with the Kit. A larger screwdriver may damage components*****

Basic Troubleshooting -

No Sound - Typically shorted wire, check for shorted wires, or wires not connected properly

Loud Hum - Typically an open signal, recheck connections

Hums when hands leave strings - Check bridge ground wire is attached and all other ground wires are properly attached. Also double check all components are interconnected with a ground lead