

IMPORTANT INSTALLATION NOTE:
TEMPORARILY REMOVE THE EXISTING "LEAF STRAINER" AND CLAMPING RING PRIOR TO THE APPLICATION OF NEW FLASHING AND FIELD SYSTEM. REINSTALL CLAMPING RING AND STRAINER AFTER THE APPLICATION OF APOC FIELD SYSTEM.

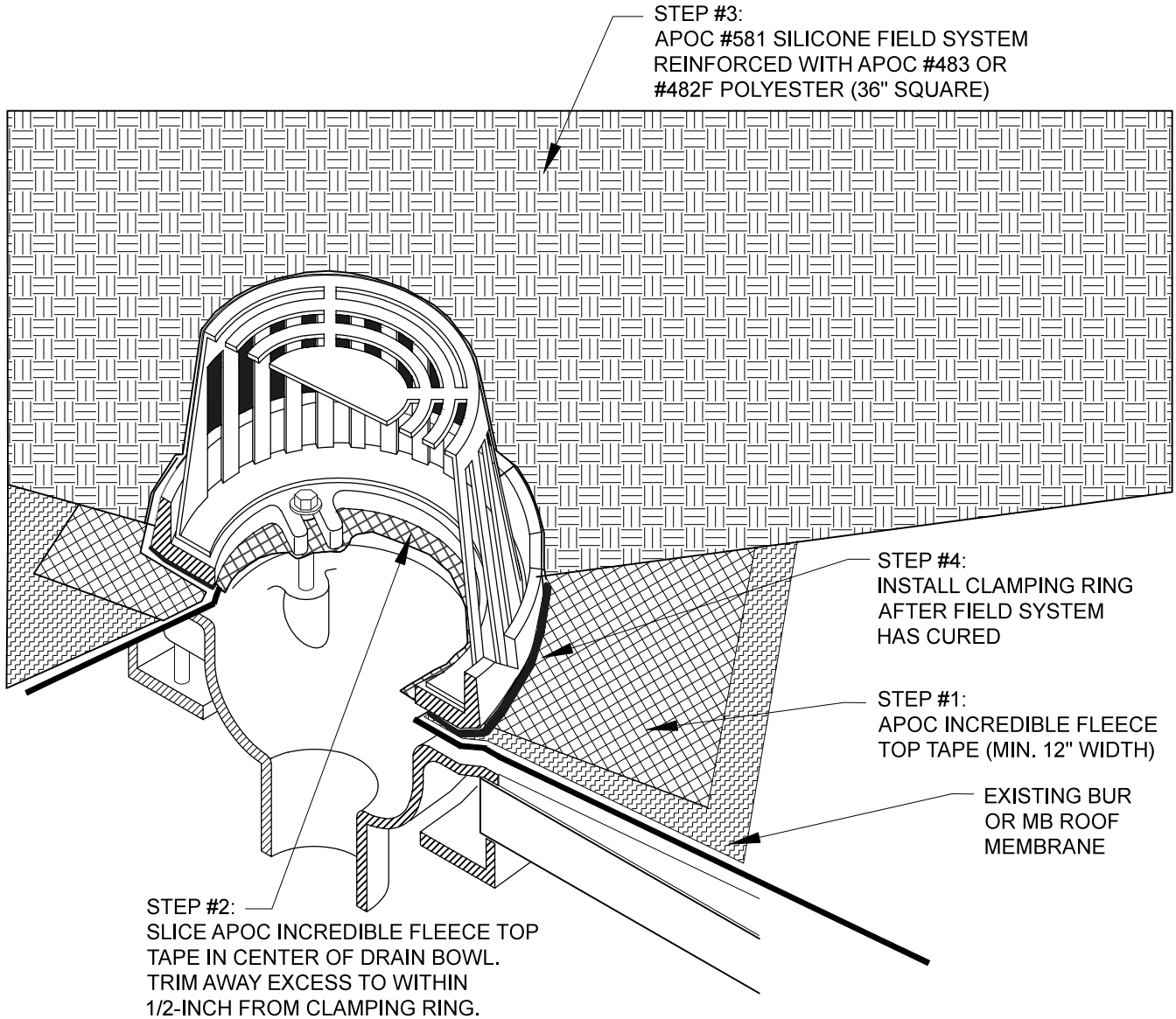

ROOF DRAIN FLASHING RESTORATION

BUR - 5
SILICONE 581

NOT TO SCALE