

# MBP

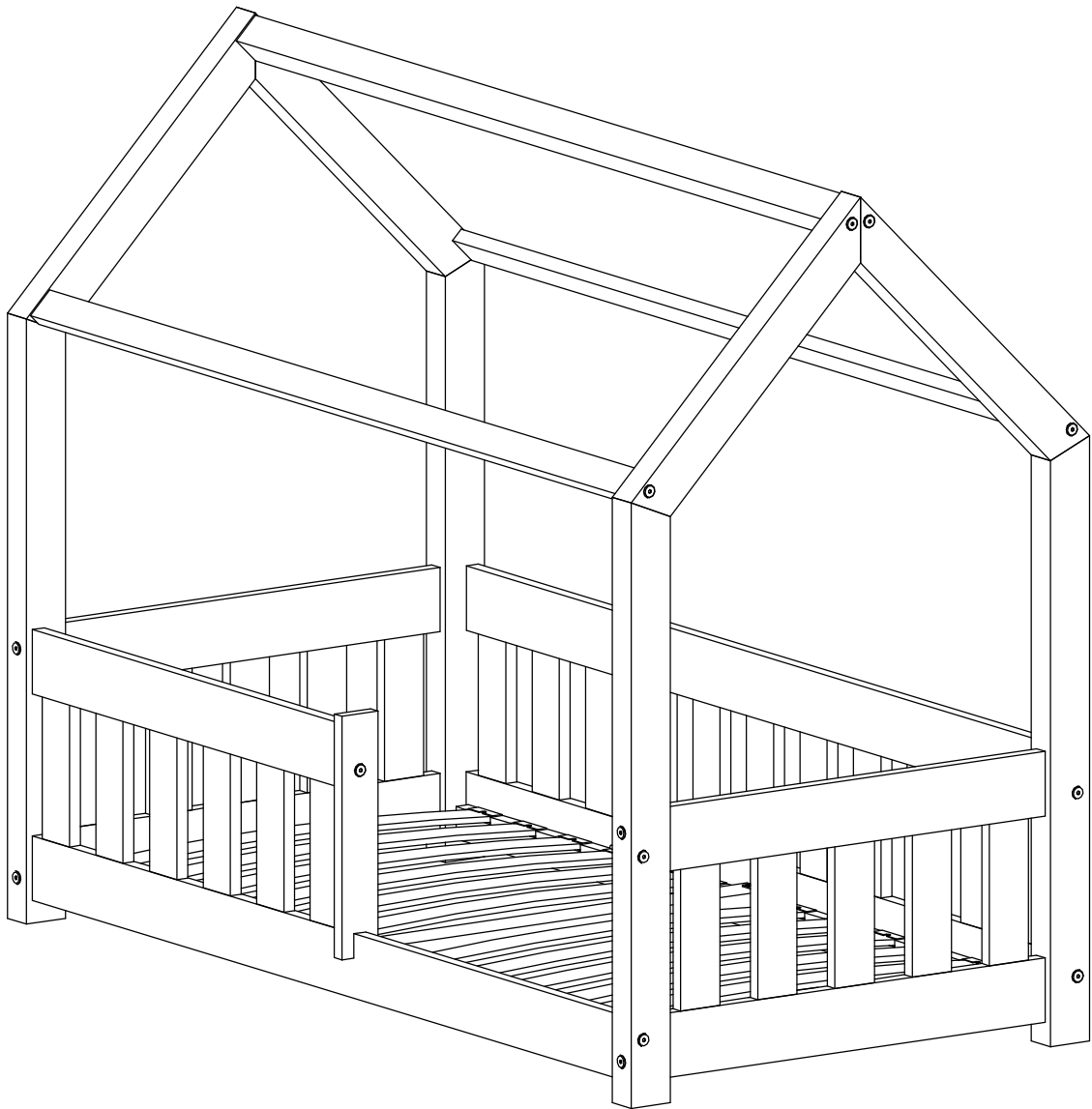

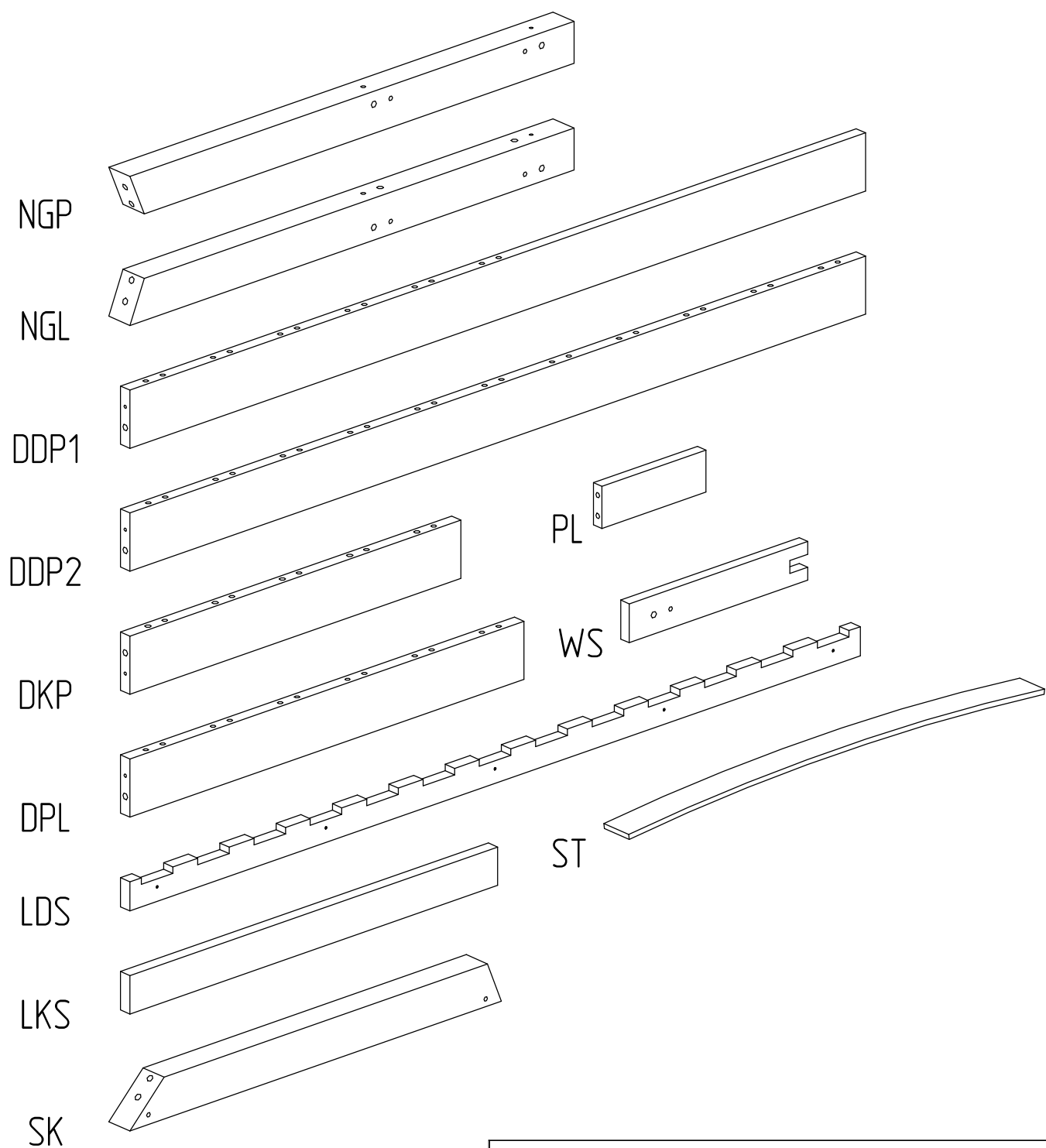

| ST                  |                |
|---------------------|----------------|
| DŁUGOŚĆ/LENGTH [cm] | ILOŚĆ/QUANTITY |
| 140                 | 12             |
| 160                 | 14             |
| 180                 | 14             |
| 190                 | 16             |
| 200                 | 16             |

| CZĘŚĆ/PART     | NGP | NGL | DDP1 | DDP2 | DKP | DPL | WS | LDS | LKS | SK |
|----------------|-----|-----|------|------|-----|-----|----|-----|-----|----|
| ILOŚĆ/QUANTITY | 2   | 2   | 1    | 2    | 4   | 1   | 1  | 2   | 1   | 4  |

# ILOŚĆ / QUANTITY OF PL

| DŁUGOŚĆ / LENGTH<br>[cm] | SZEROKOŚĆ / WIDTH [cm] |    |    |     |     |     |     |     |
|--------------------------|------------------------|----|----|-----|-----|-----|-----|-----|
|                          | 70                     | 80 | 90 | 100 | 120 | 135 | 140 | 160 |
| 140                      | 27                     | 27 | 29 | -   | -   | -   | -   | -   |
| 160                      | 28                     | 28 | 30 | -   | -   | -   | -   | -   |
| 180                      | -                      | 31 | 33 | 35  | 39  | 41  | 41  | 45  |
| 190                      | -                      | 33 | 35 | 37  | 41  | 43  | 43  | 47  |
| 200                      | -                      | 33 | 35 | 37  | 41  | 43  | 43  | 47  |

S110

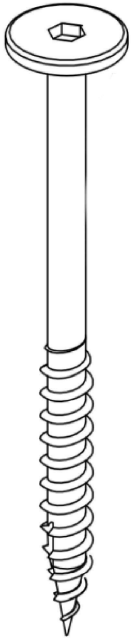

S80

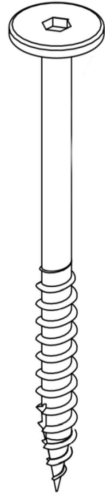

S50

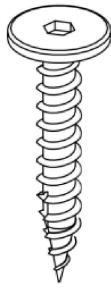

W30

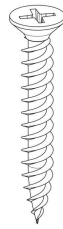

K10



K8



W16



G

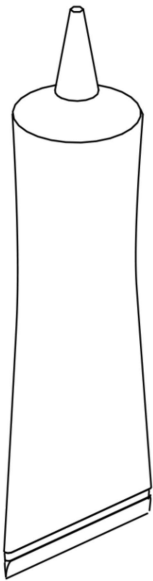

KT

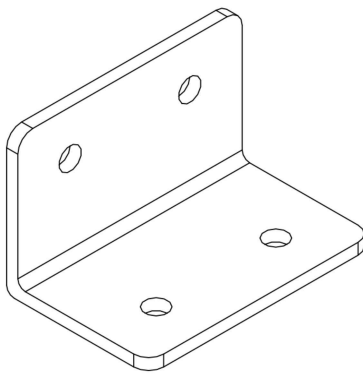

P

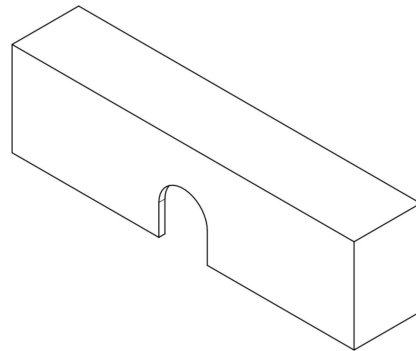

INBUS

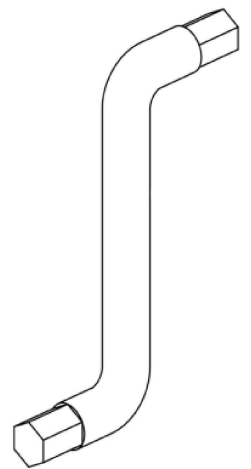

| P                   |                |
|---------------------|----------------|
| DŁUGOŚĆ/LENGTH [cm] | ILOŚĆ/QUANTITY |
| 140                 | 24             |
| 160                 | 28             |
| 180                 | 28             |
| 190                 | 32             |
| 200                 | 32             |

| CZEŚĆ/PART     | S110 | S80 | S50 | W30 | K10 | W16 | G | KT |
|----------------|------|-----|-----|-----|-----|-----|---|----|
| ILOŚĆ/QUANTITY | 8    | 15  | 1   | 12  | 28  | 8   | 4 | 2  |

# ILOŚĆ / QUANTITY OF K8

| DŁUGOŚĆ / LENGTH<br>[cm] | SZEROKOŚĆ / WIDTH [cm] |     |     |     |     |     |     |     |
|--------------------------|------------------------|-----|-----|-----|-----|-----|-----|-----|
|                          | 70                     | 80  | 90  | 100 | 120 | 135 | 140 | 160 |
| 140                      | 108                    | 108 | 116 | -   | -   | -   | -   | -   |
| 160                      | 112                    | 112 | 120 | -   | -   | -   | -   | -   |
| 180                      | -                      | 124 | 132 | 140 | 156 | 164 | 164 | 180 |
| 190                      | -                      | 132 | 140 | 148 | 164 | 172 | 172 | 180 |
| 200                      | -                      | 132 | 140 | 148 | 164 | 172 | 172 | 180 |

W30

G

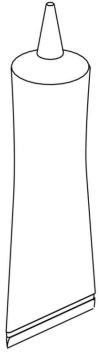
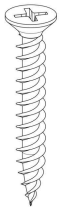

1

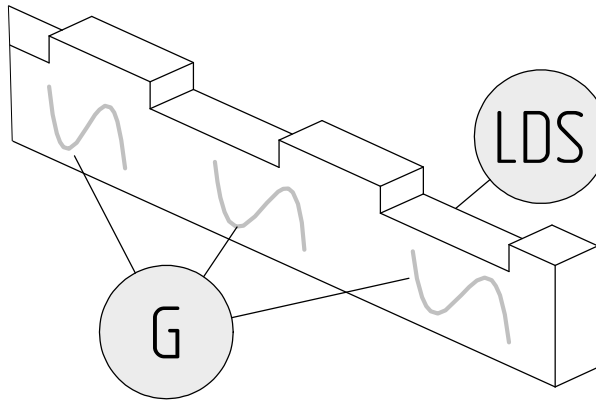

LDS

G

2

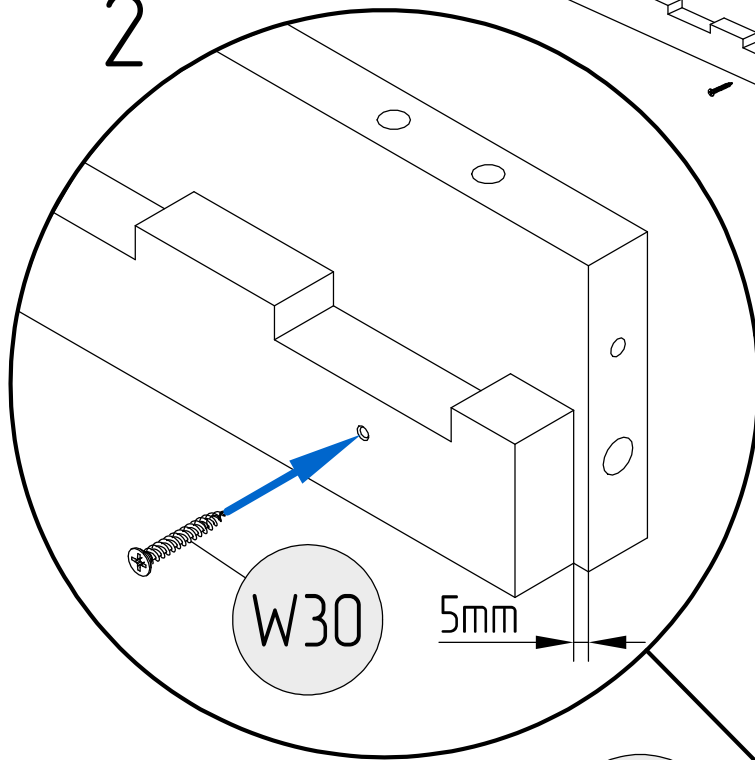

W30

5mm

DDP2

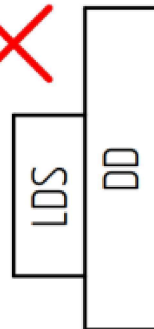
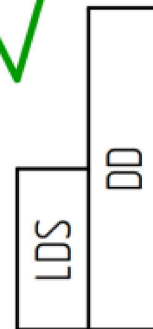

DDP1

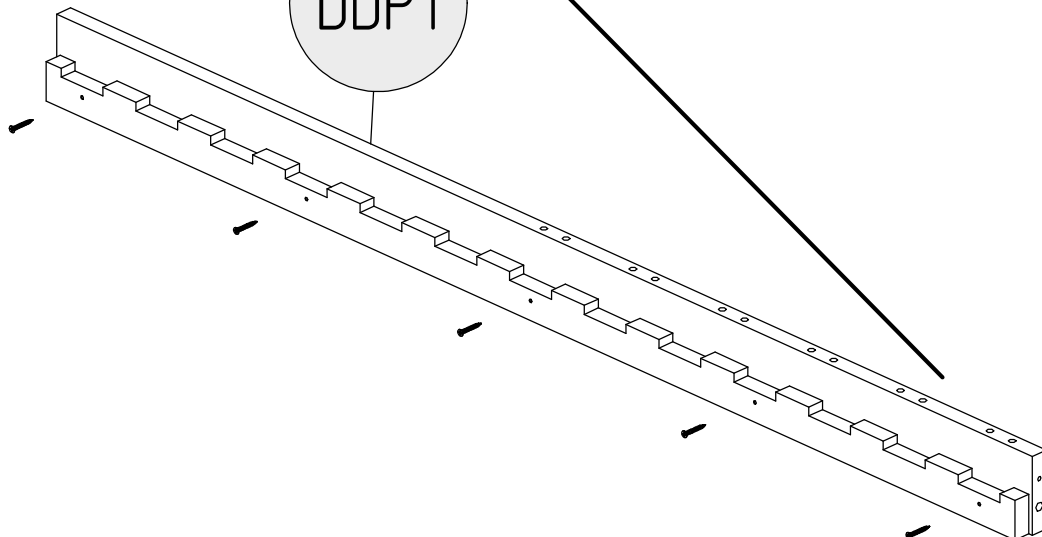

G K10

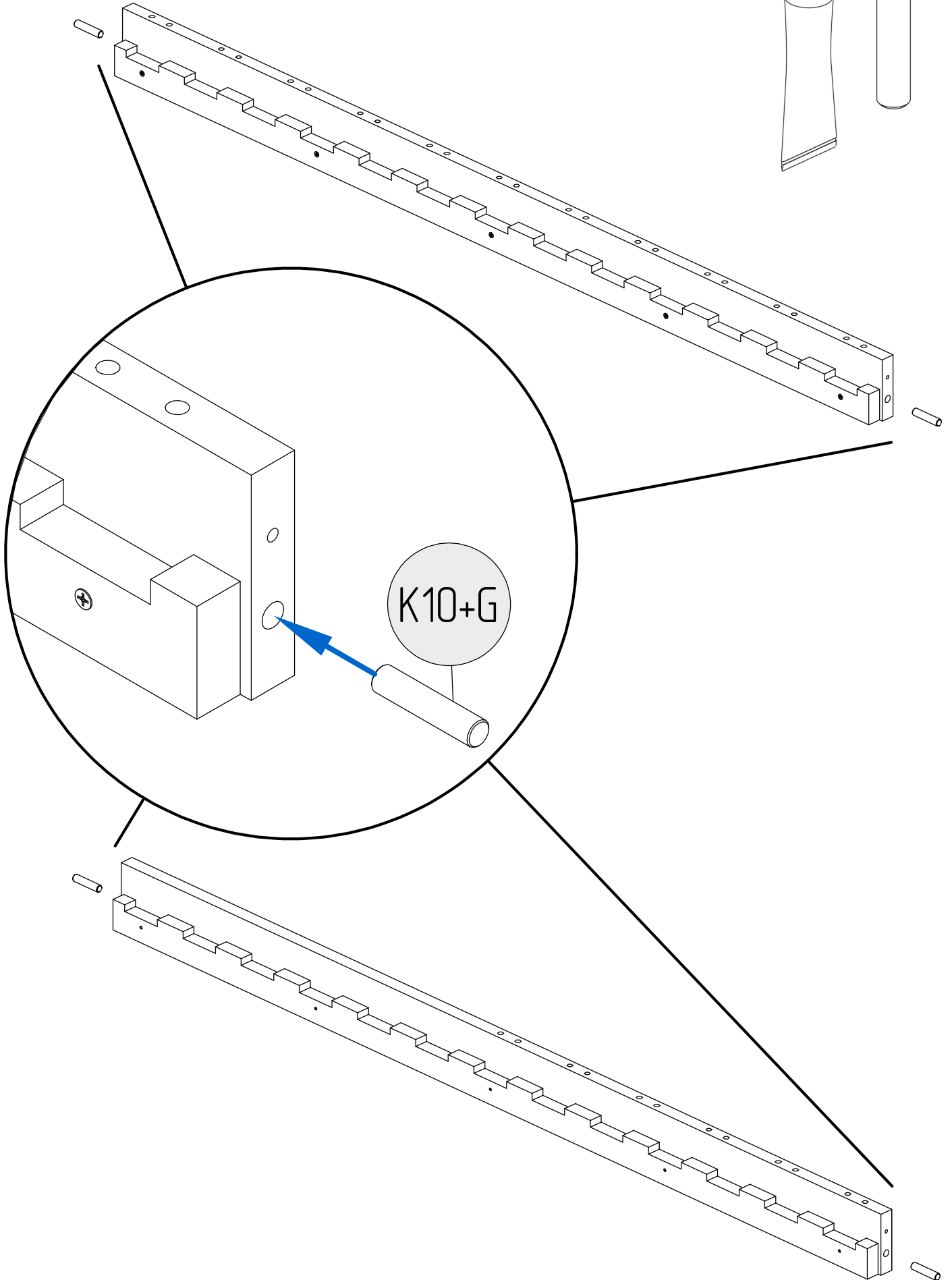
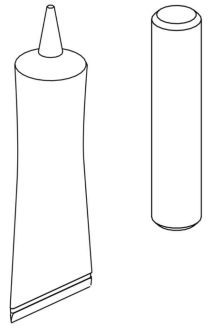

G

K10

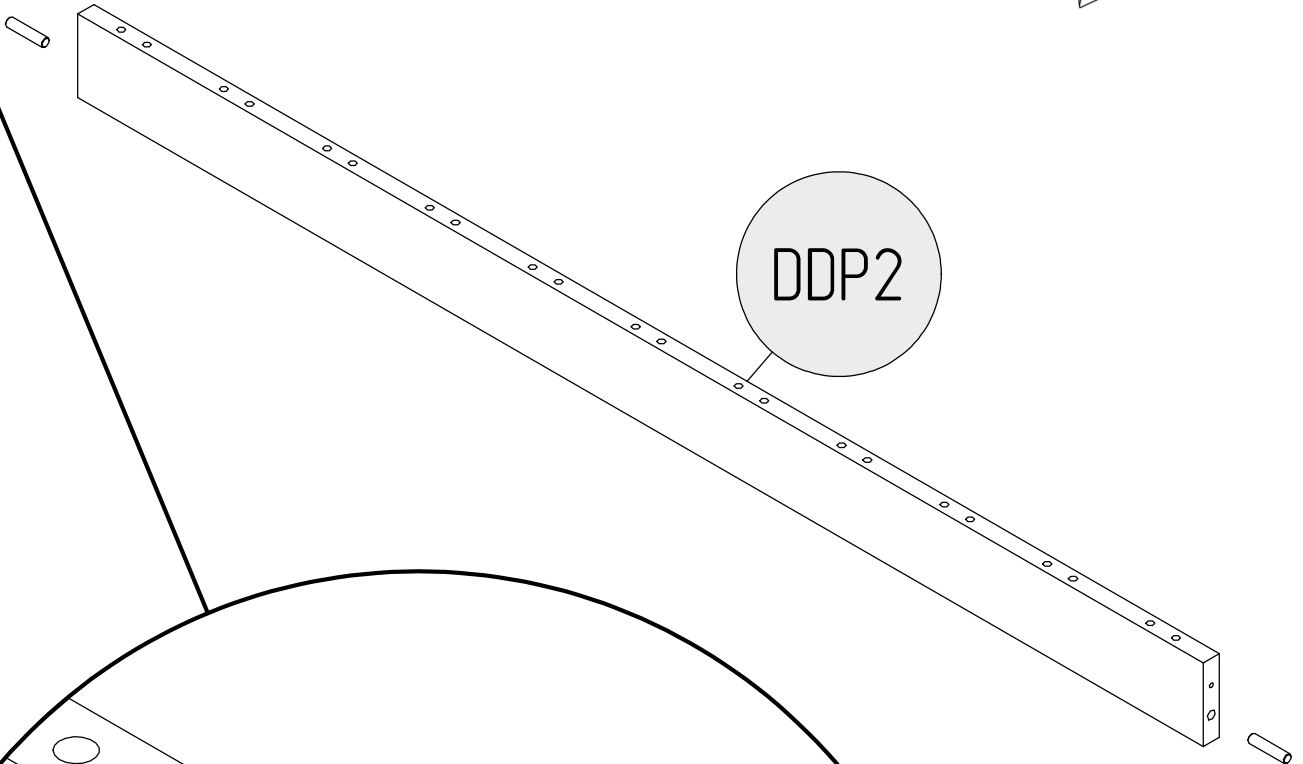
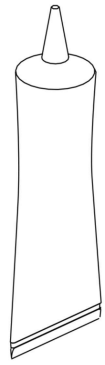

DDP2

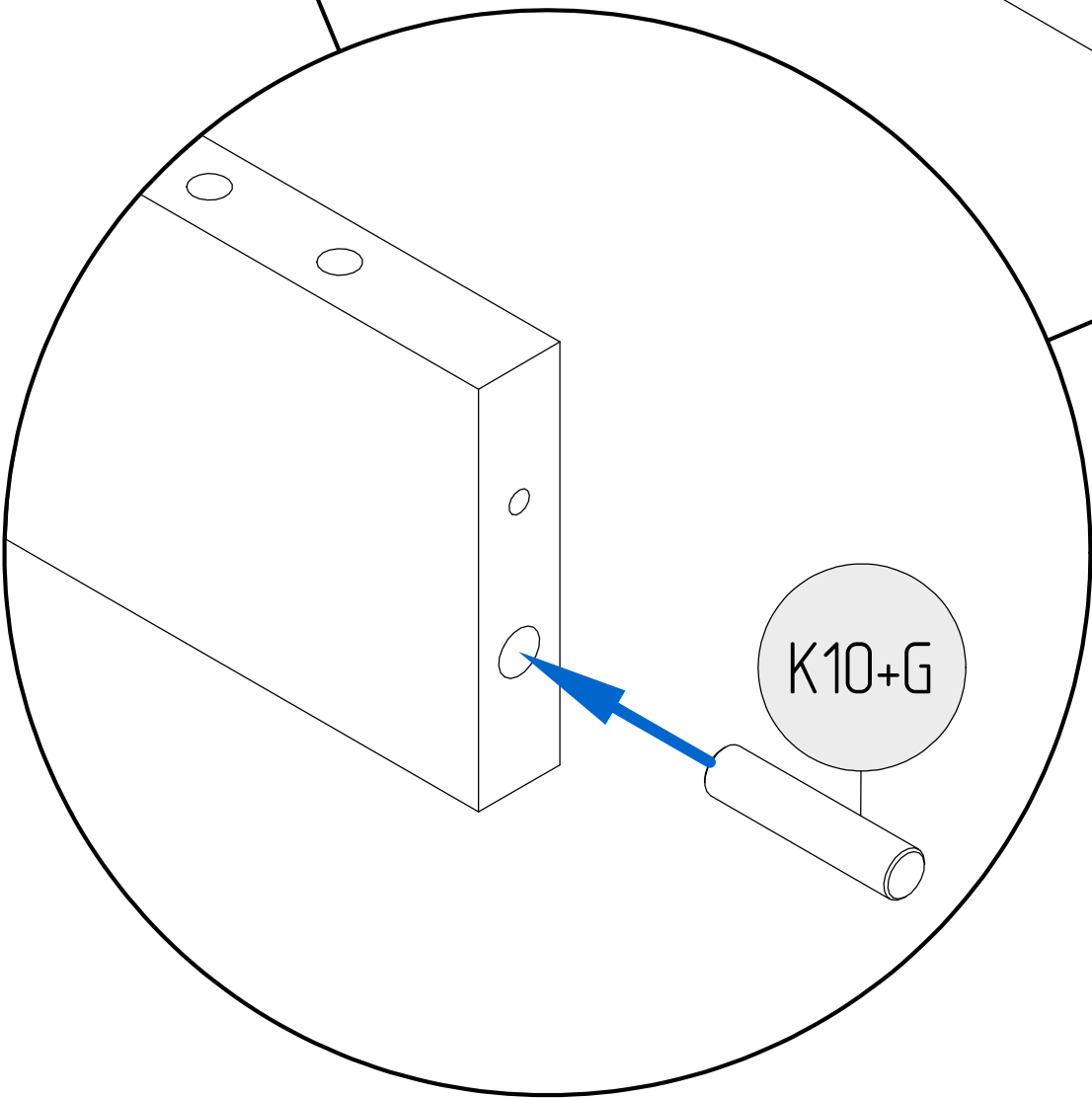

K10+G



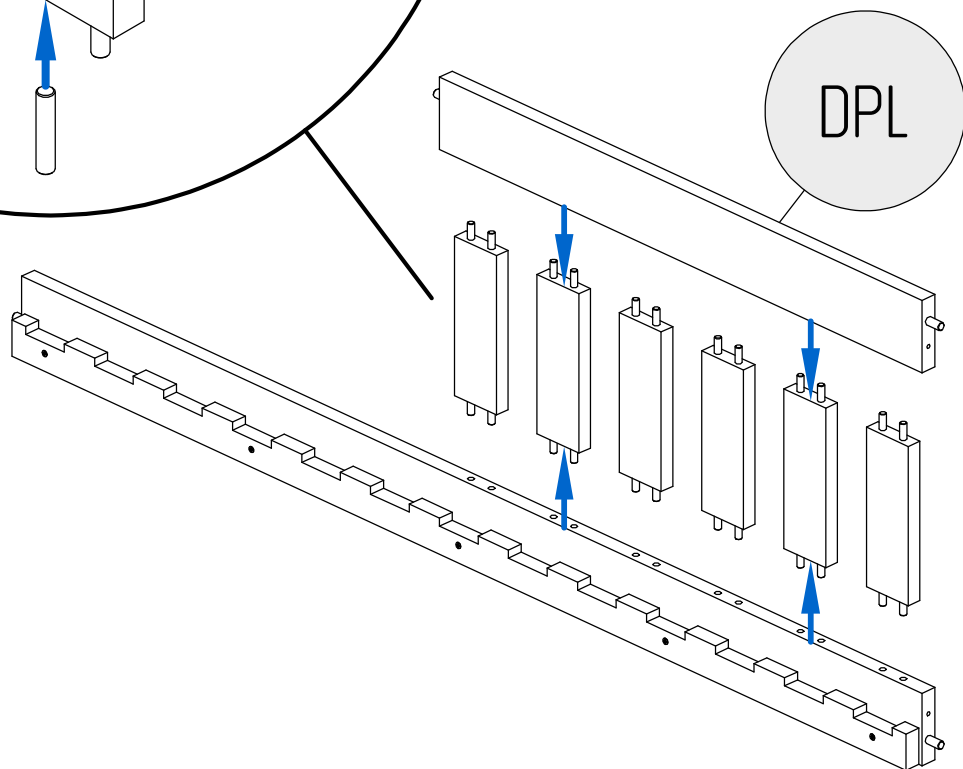
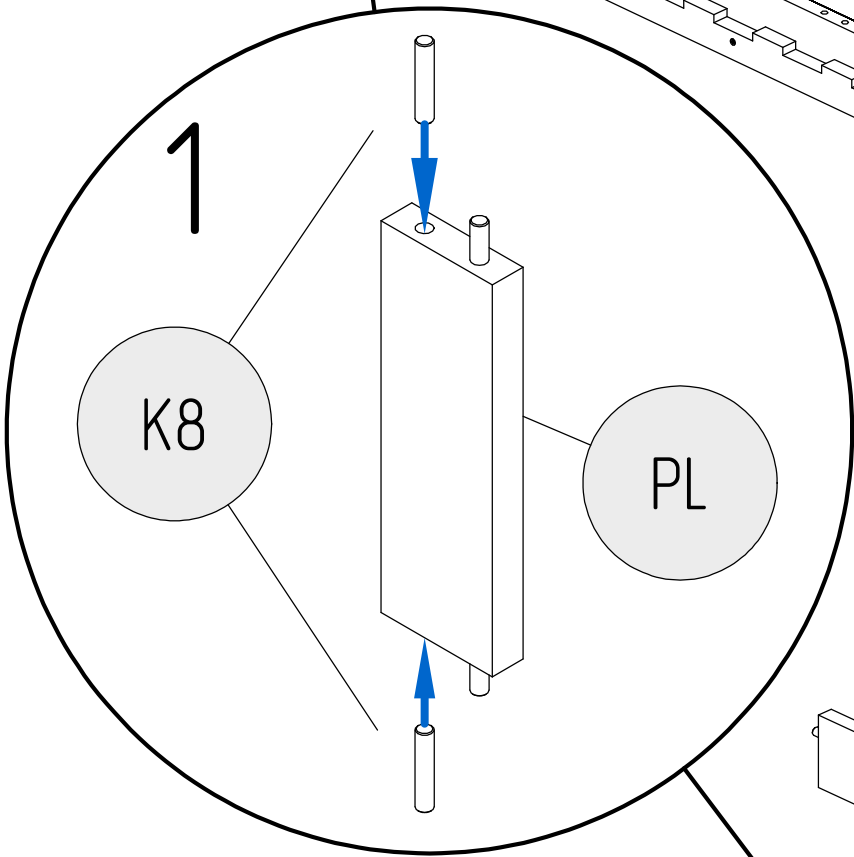
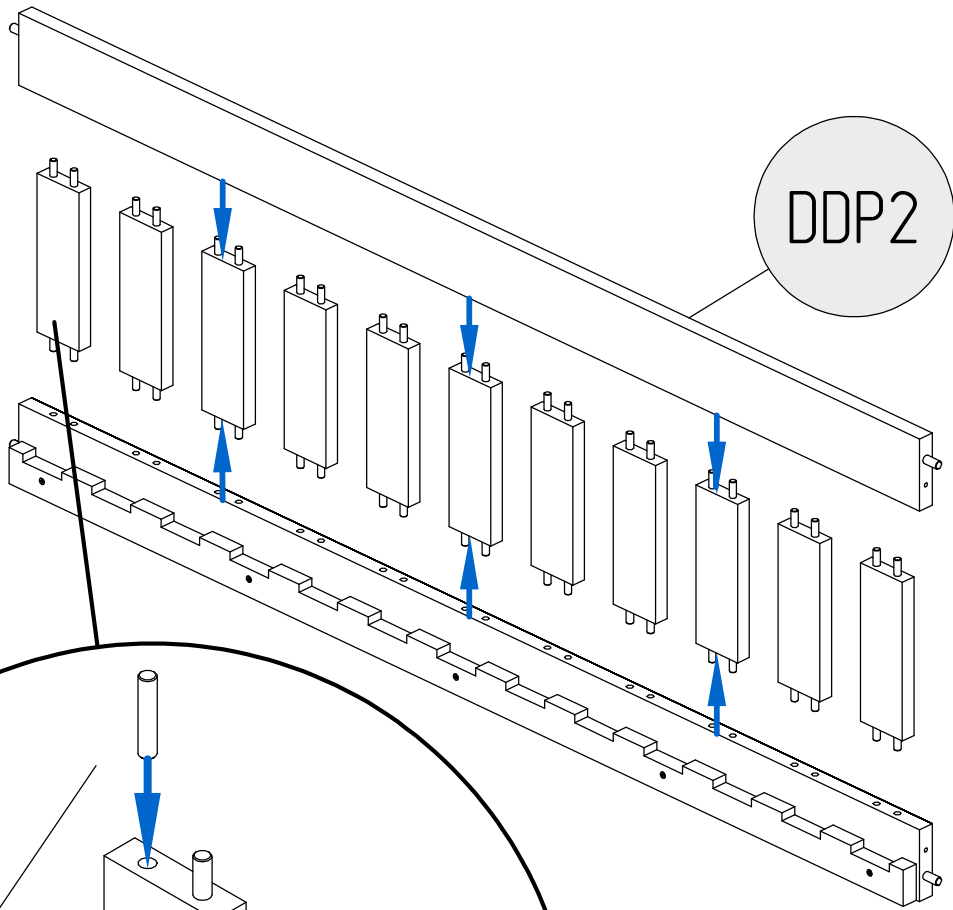

K8



2

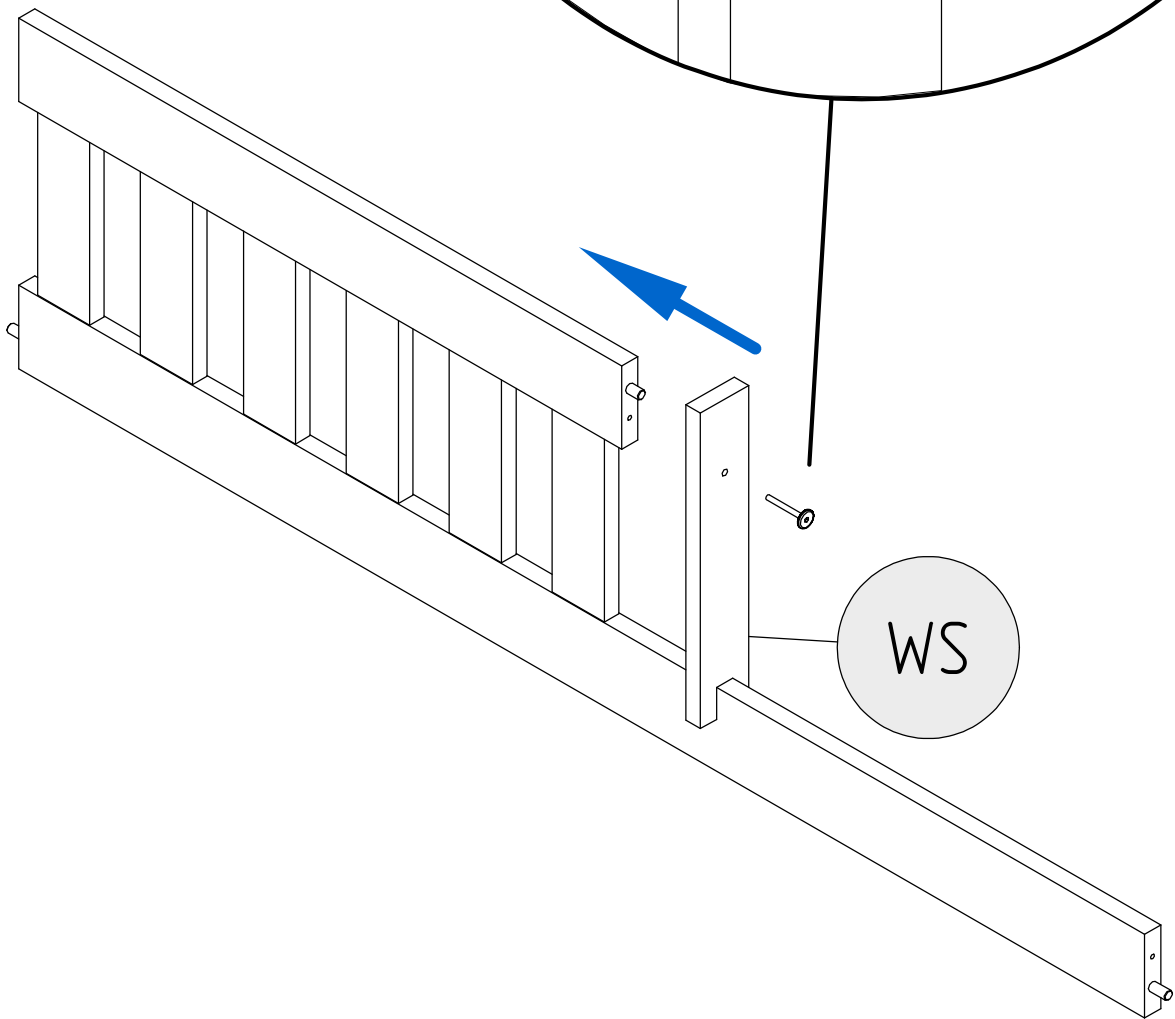
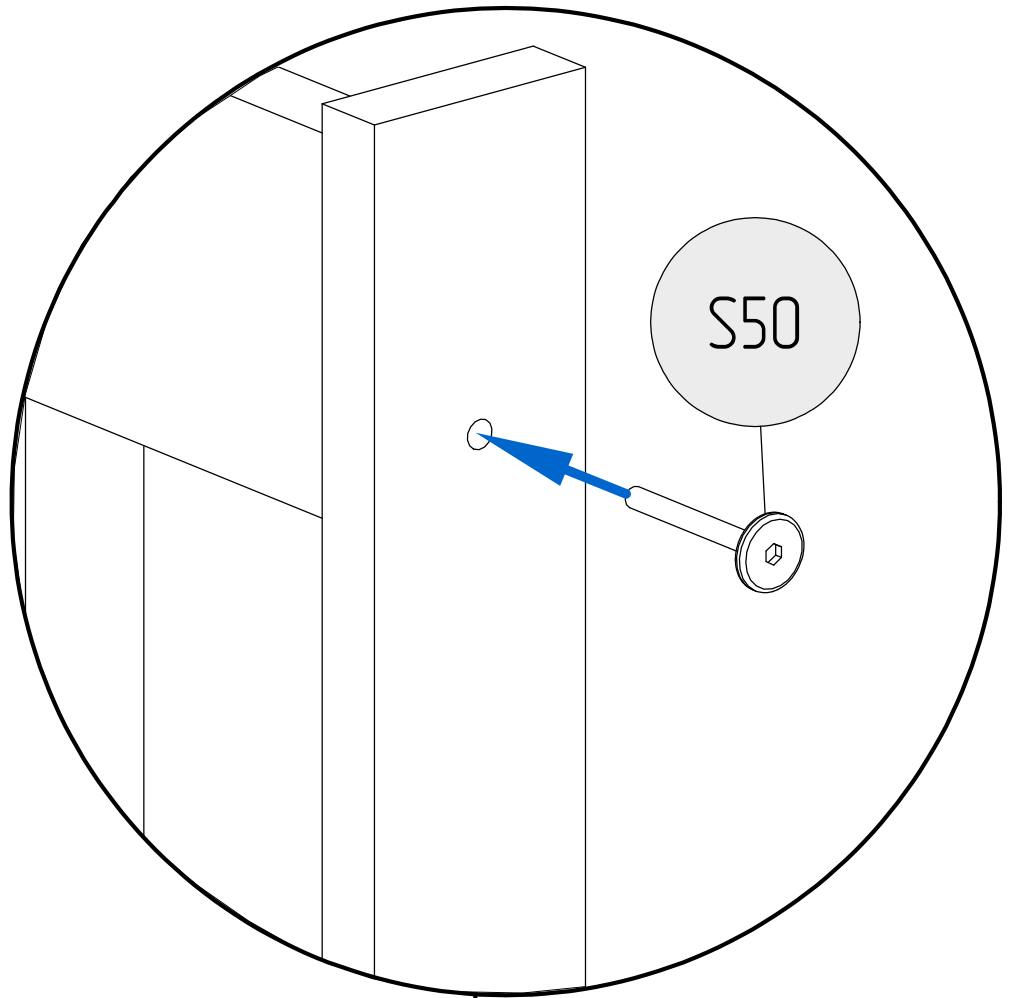
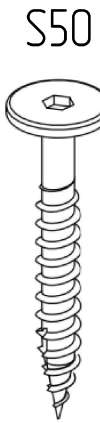

G

K10

X4

DKP

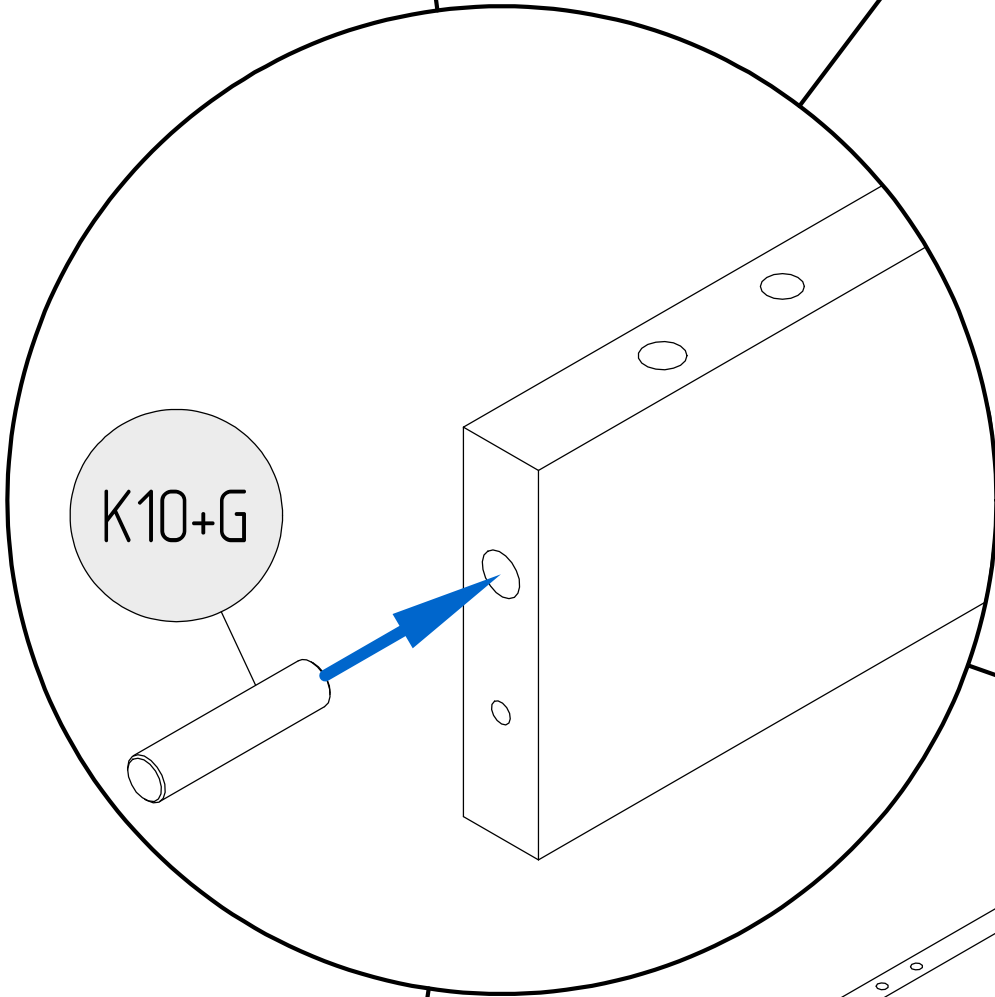
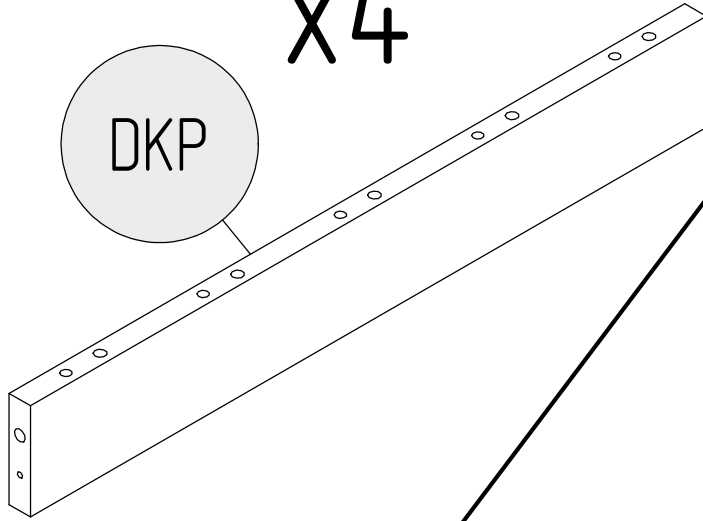
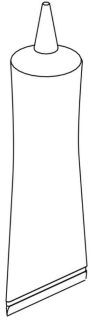

K10+G

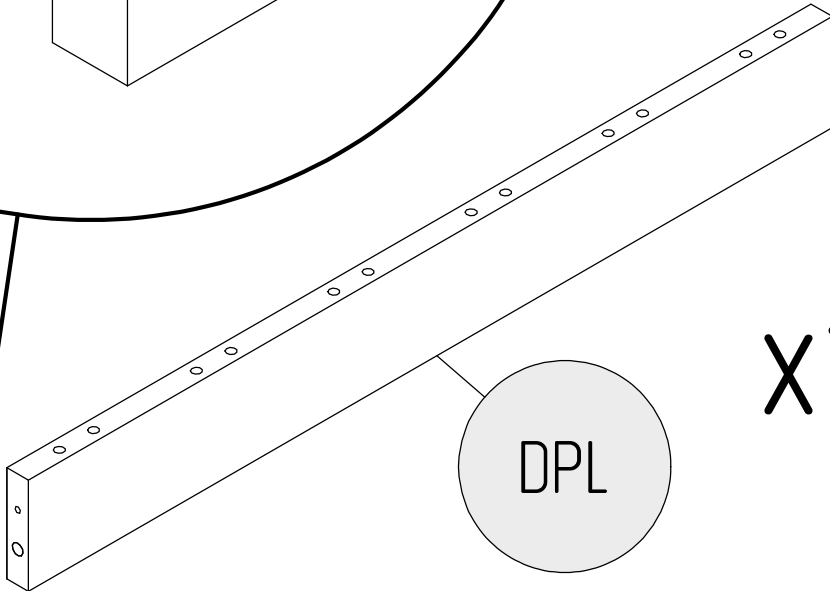

DPL

X1



K8



2

DKP

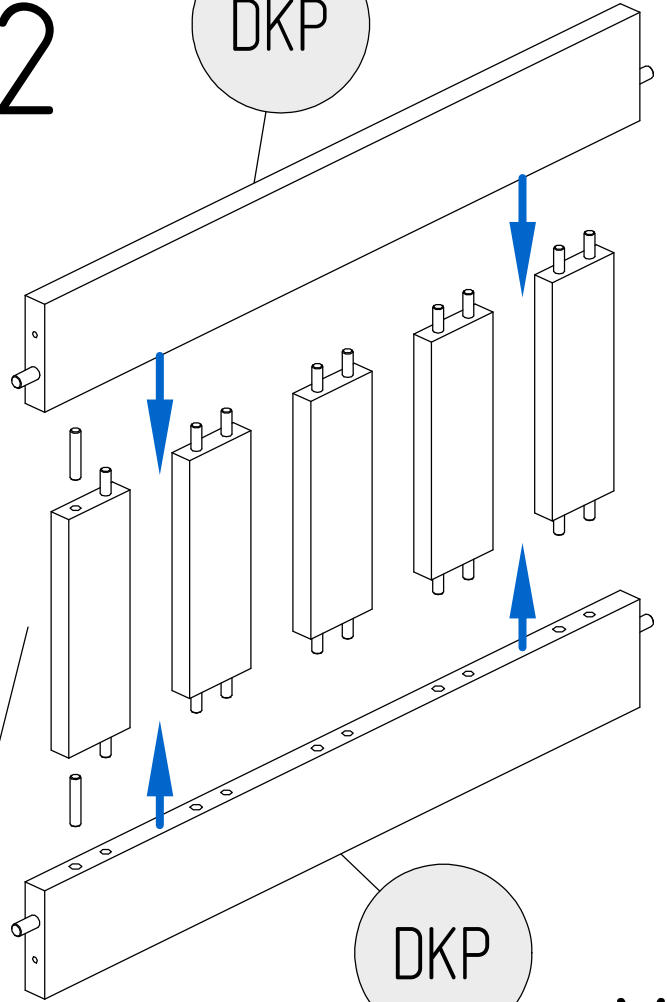

DKP

x2

1

K8

PL

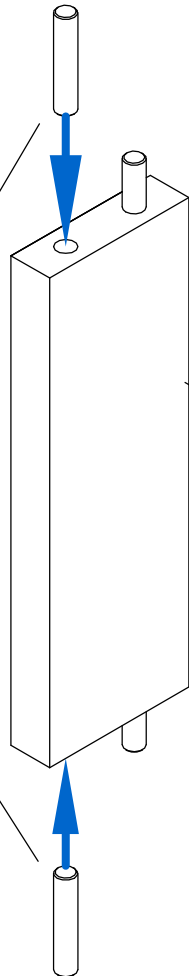

G K10

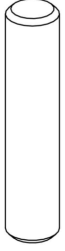
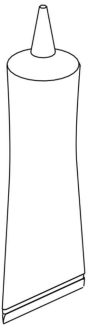

X4

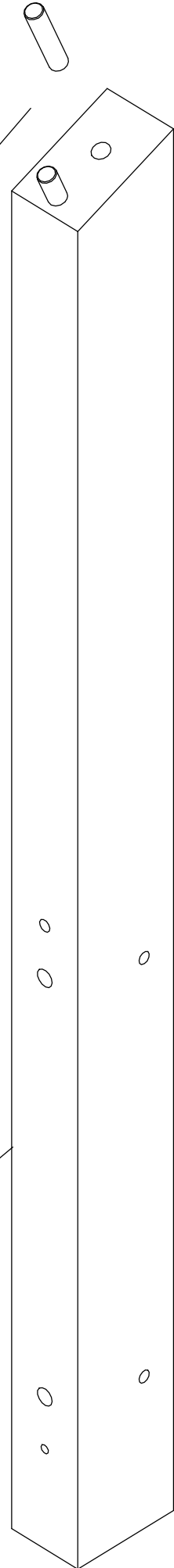
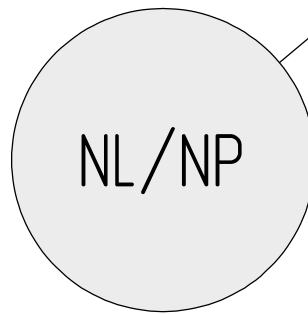
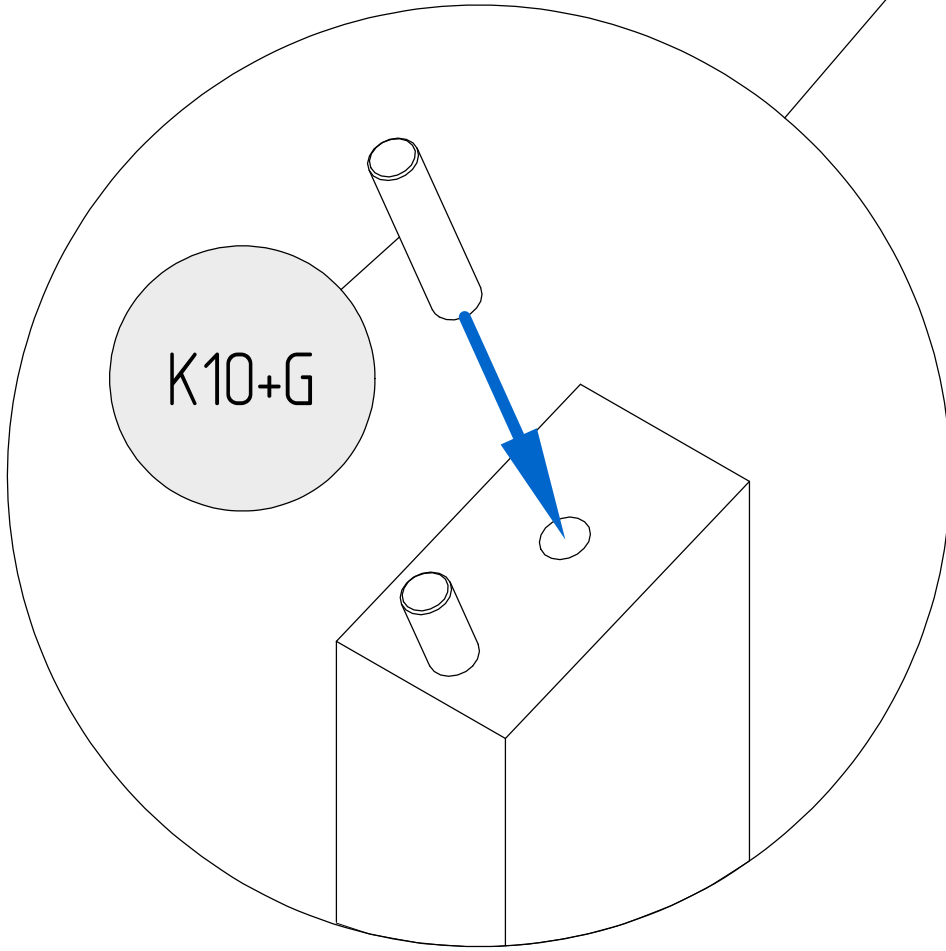

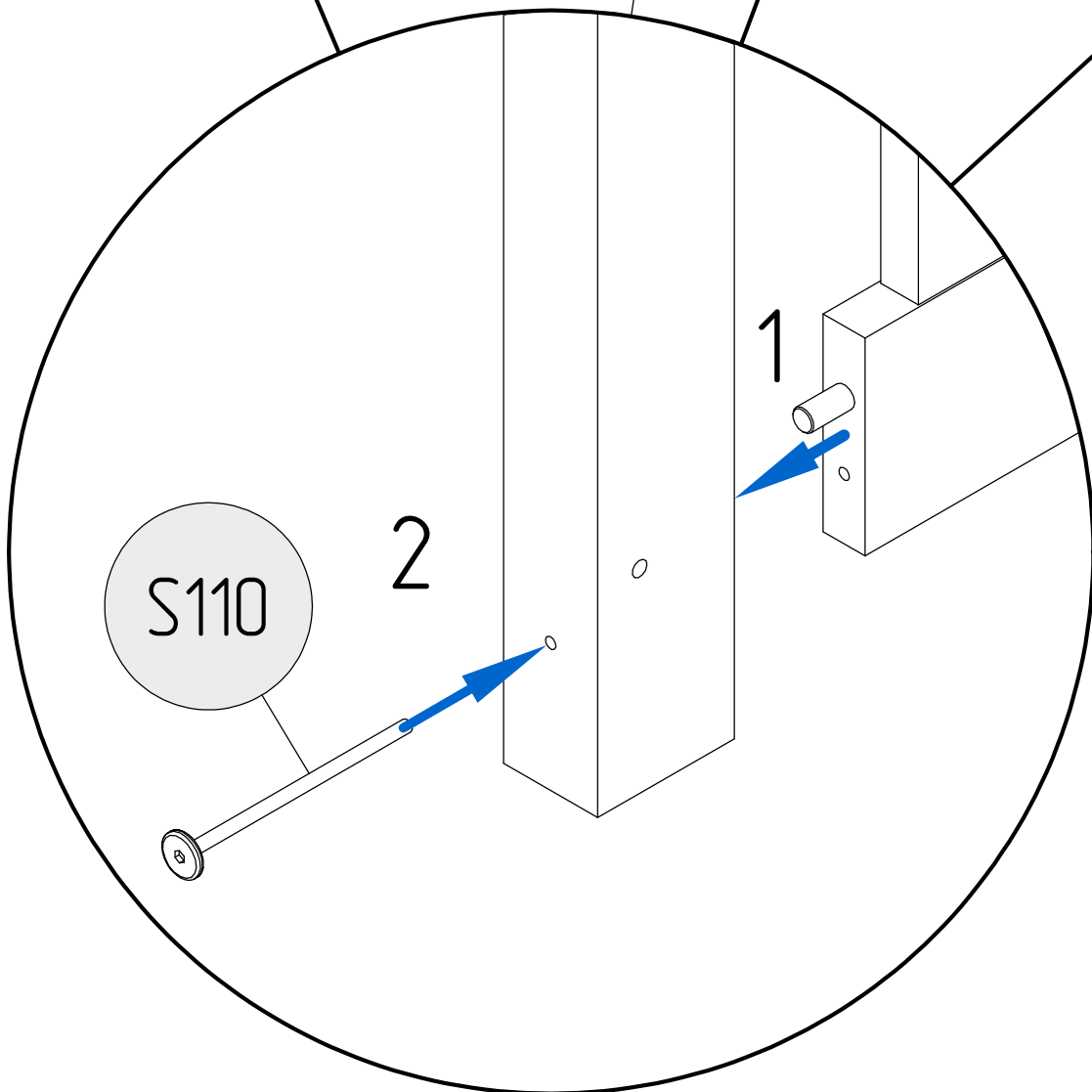
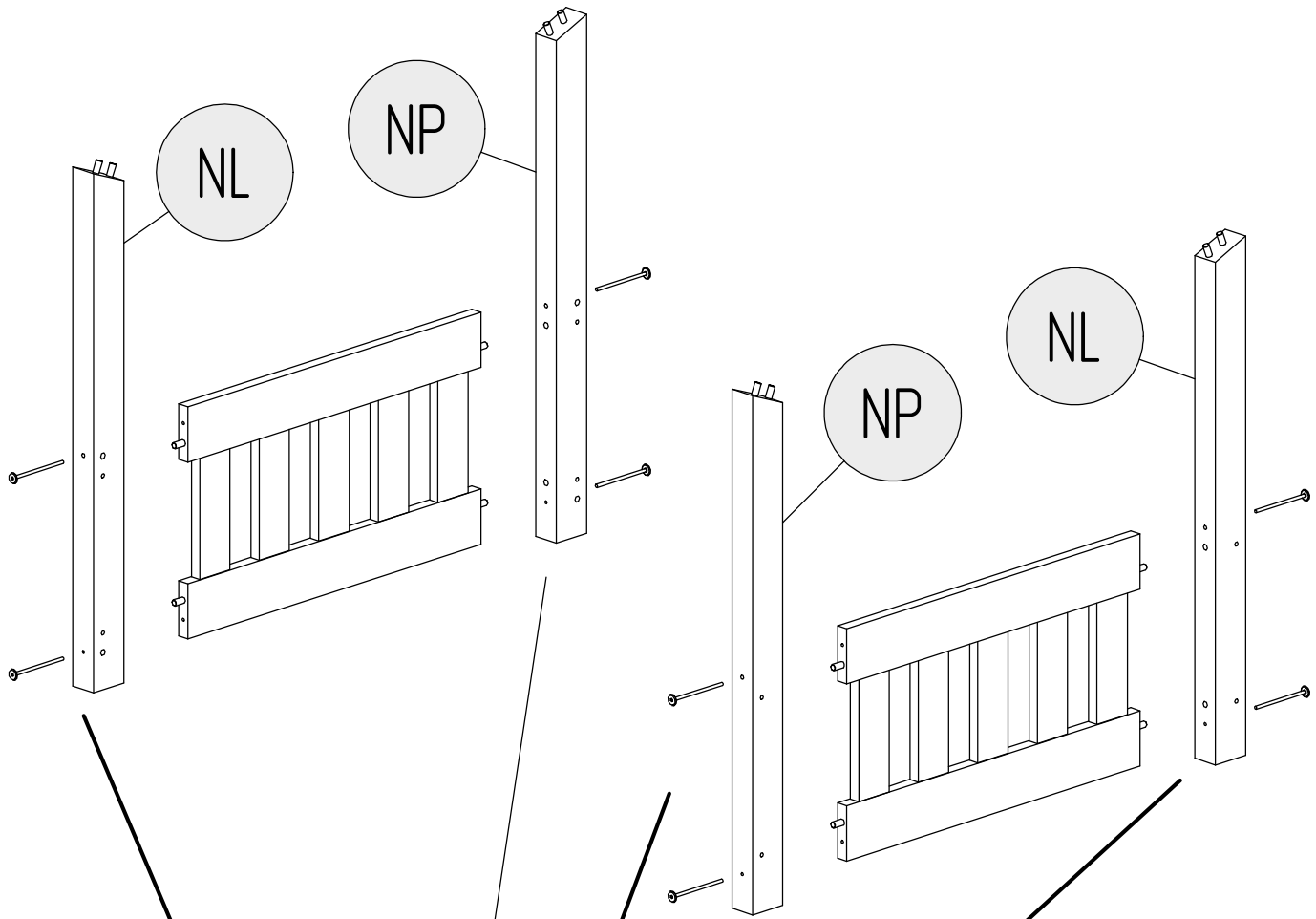

S110

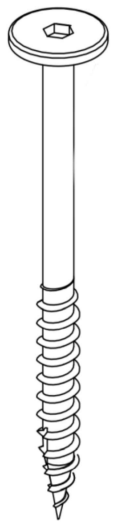

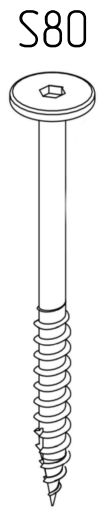
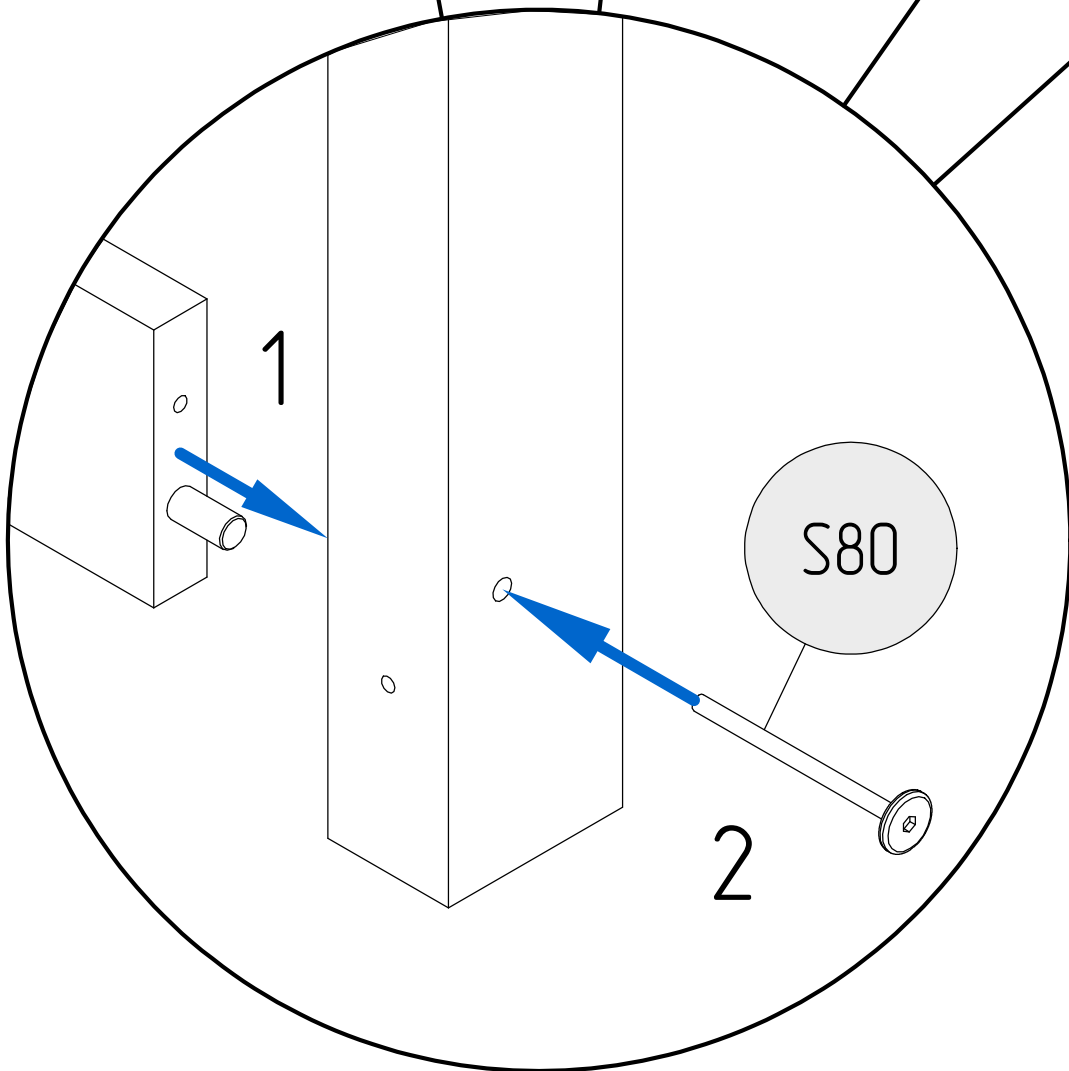
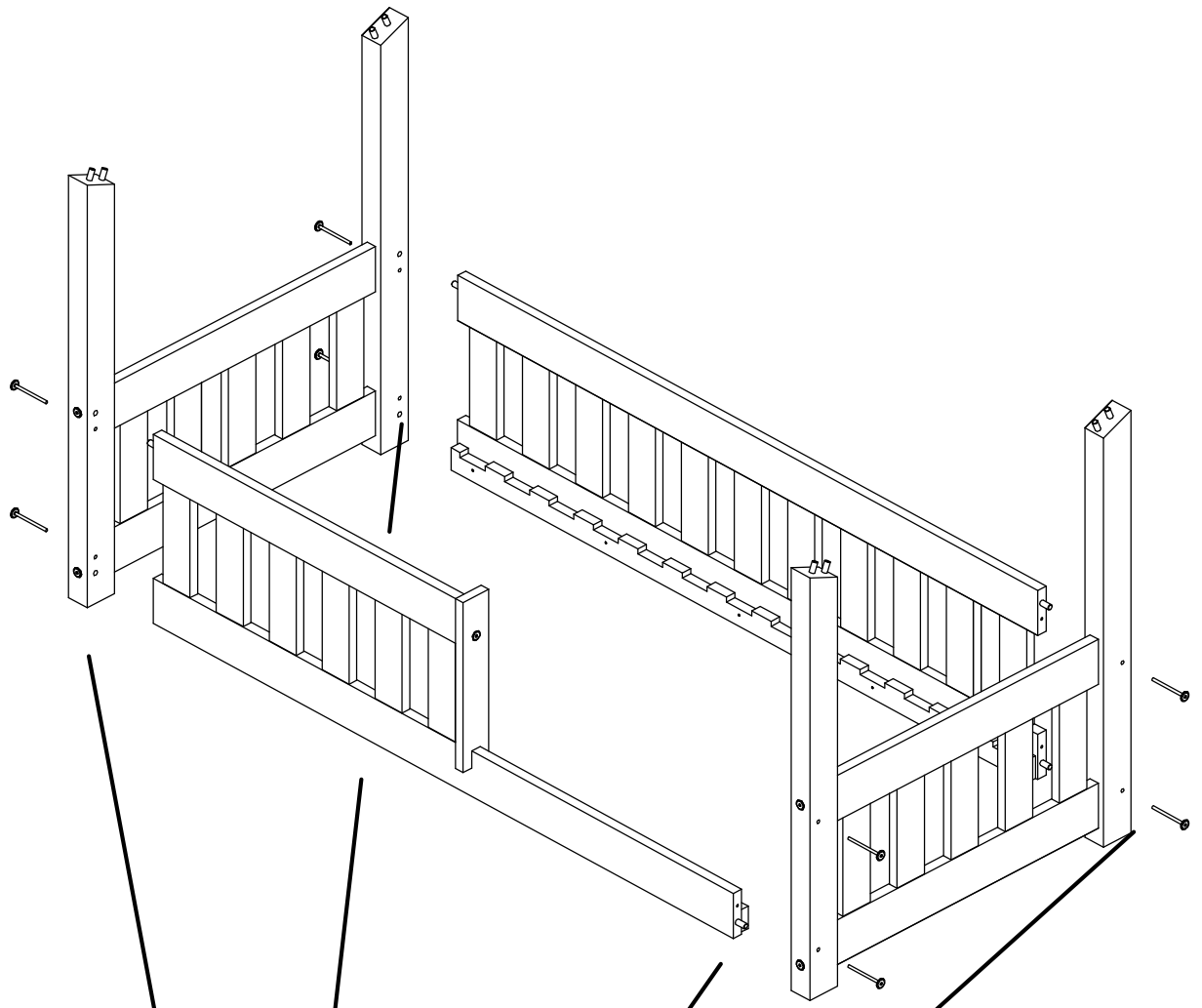

W16

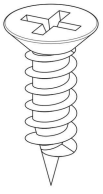

KT

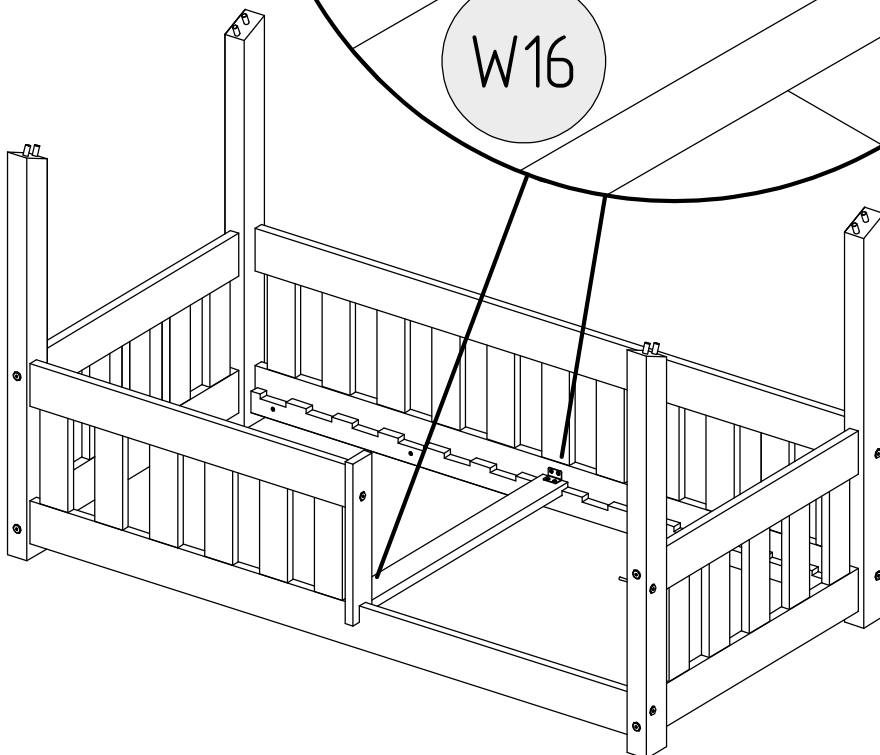
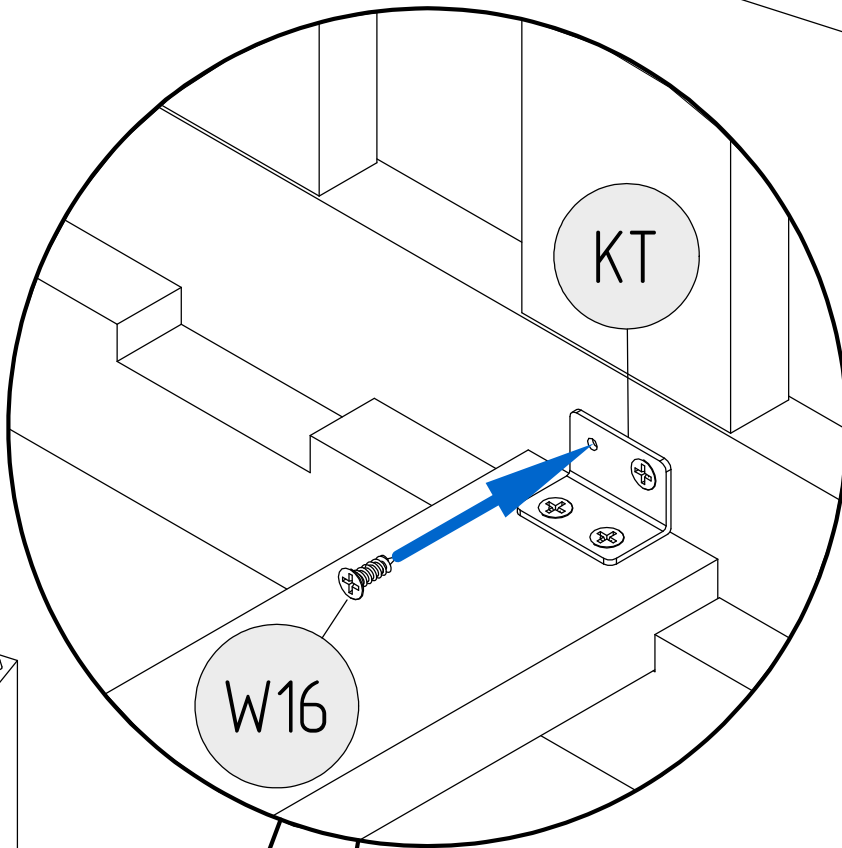
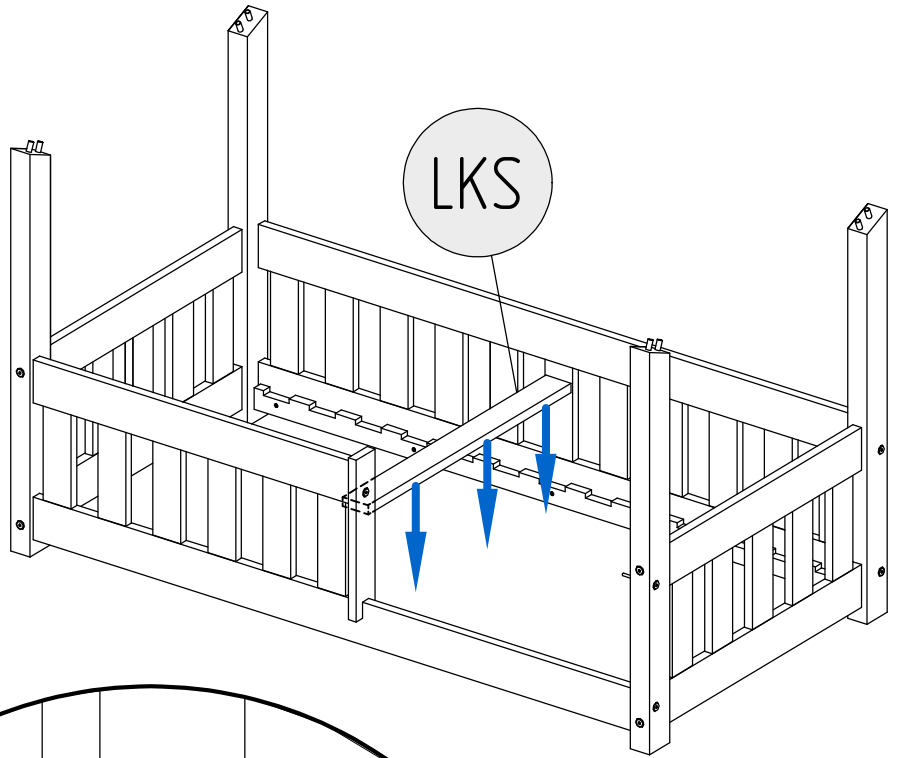
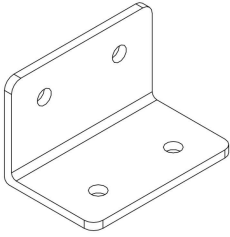



1

G

K10

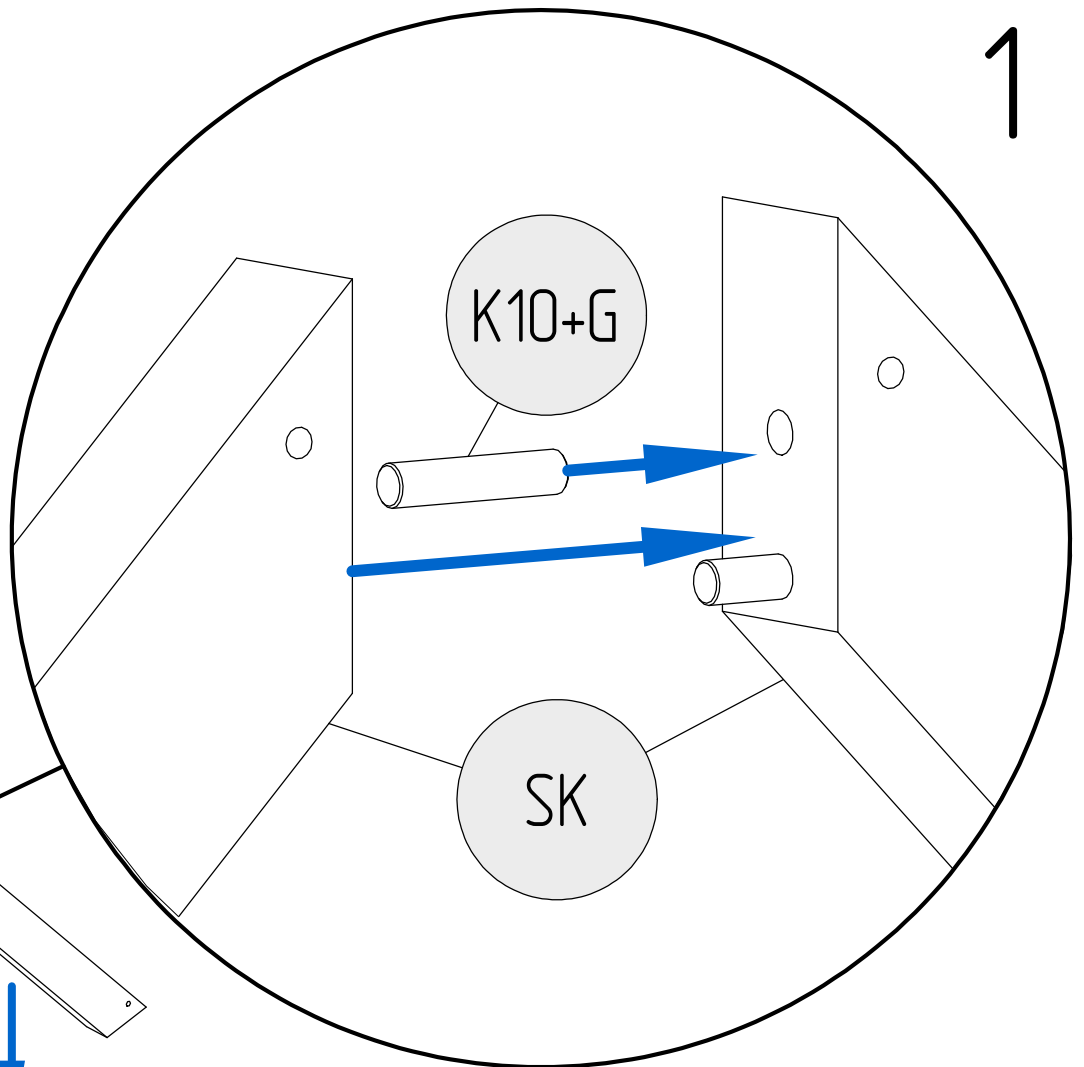
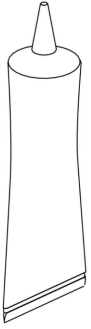

2

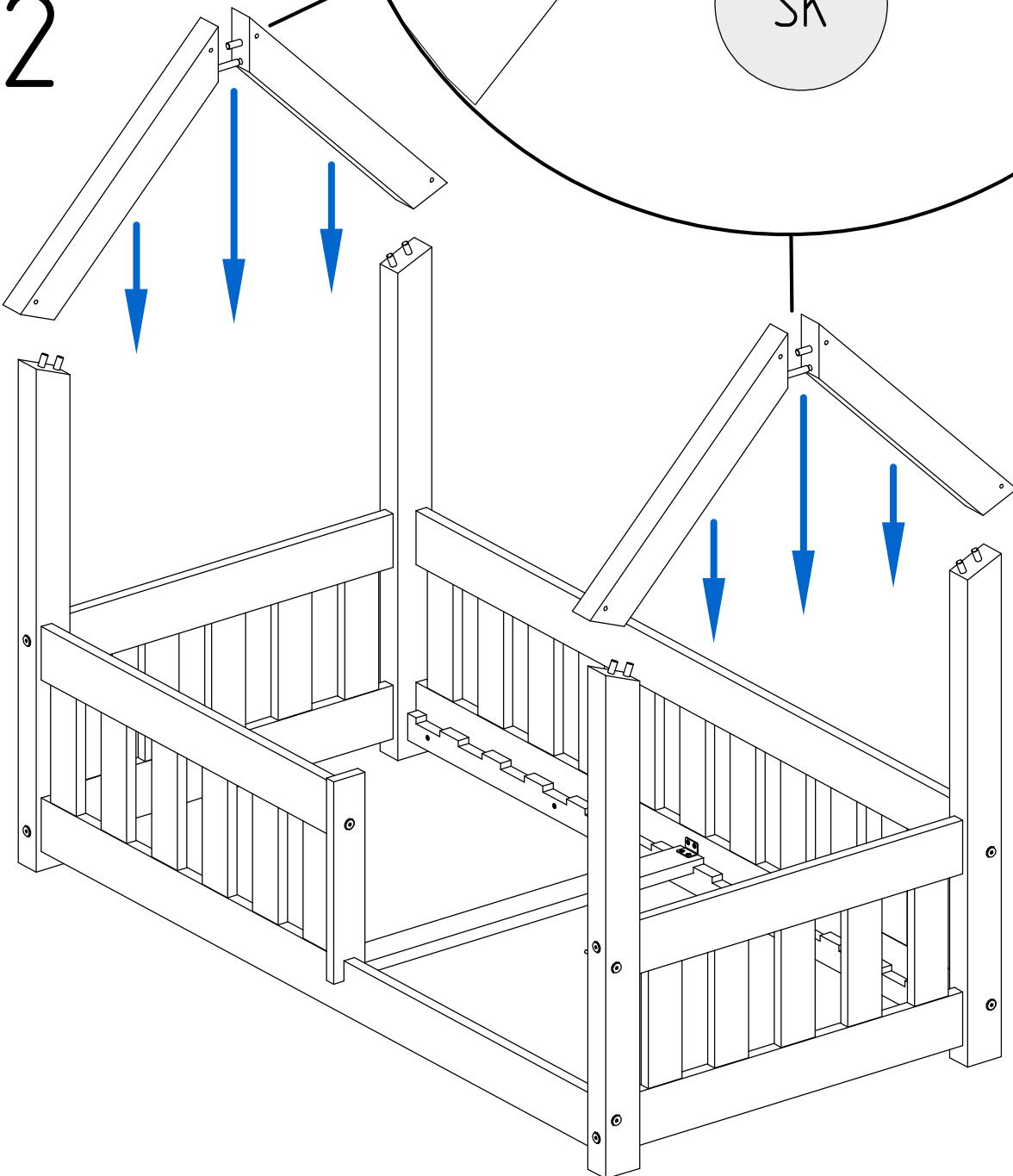

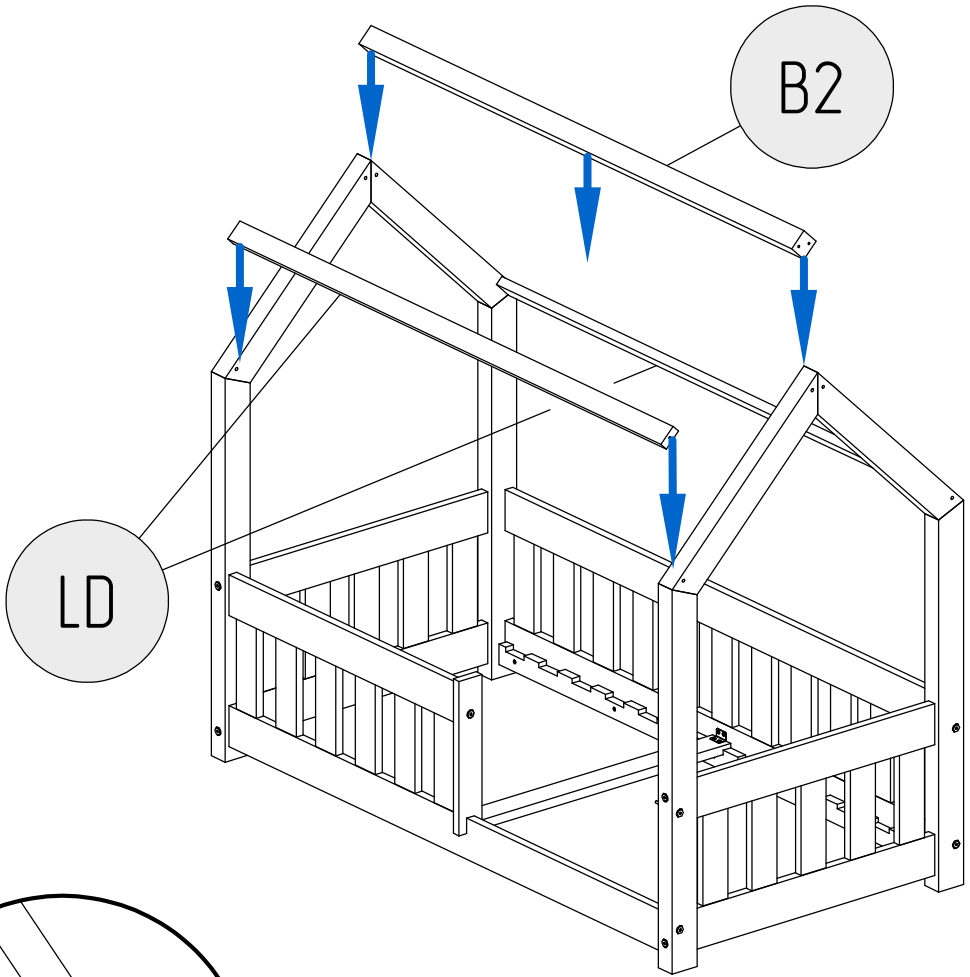

S80

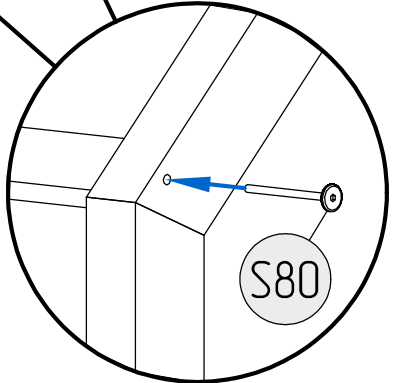
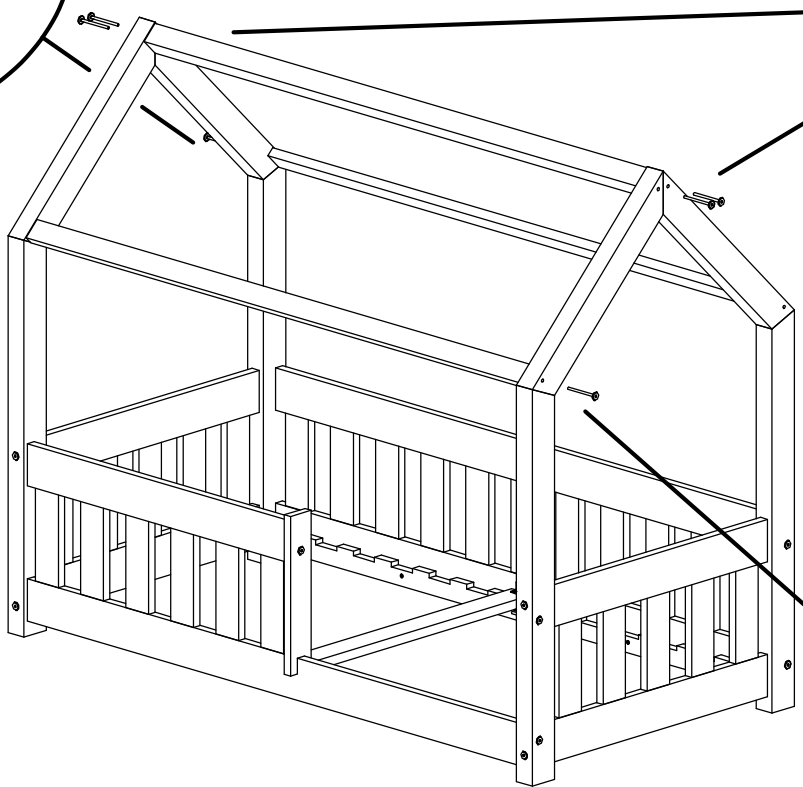
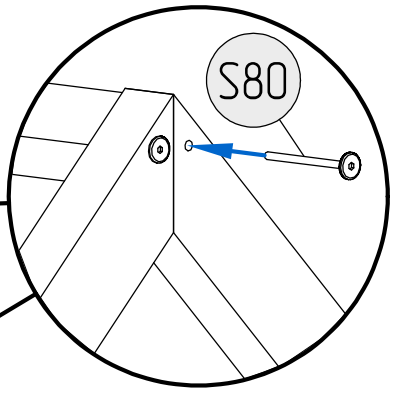
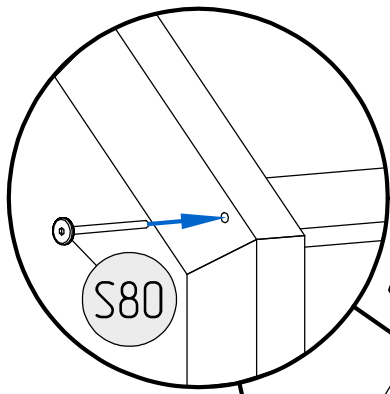
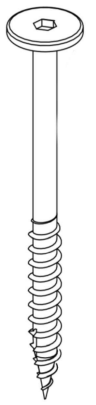

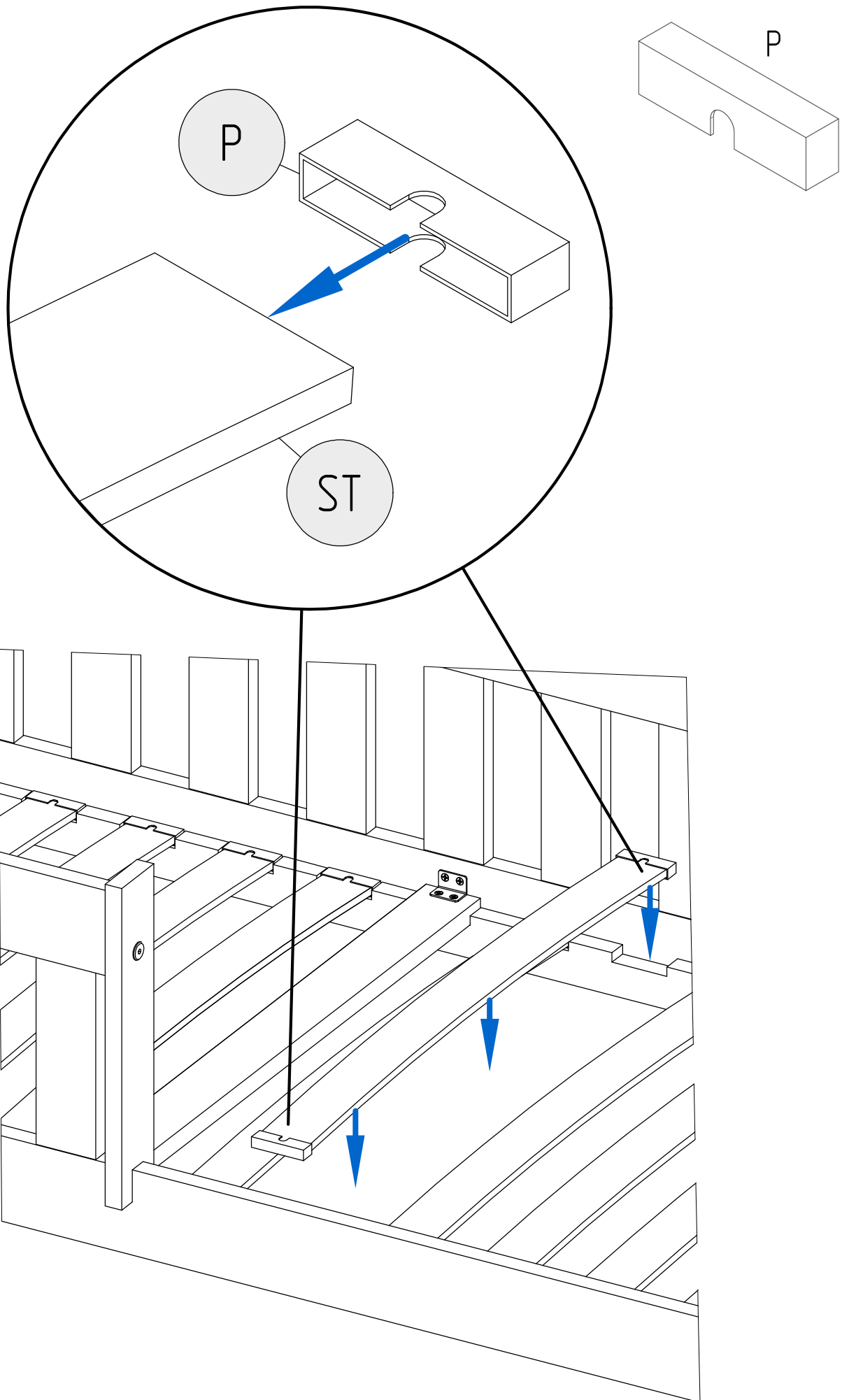

MONTAŻ ŁÓŻEK O SZEROKOŚCI POWYŻEJ 100 cm,  
UZUPEŁNIAMY NINIEJSZĄ INSTRUKCJĄ,

INSTALATION OF BEDS OVER 100 cm WIDE,  
WE COMPLEMENT THIS INSTRUCTION

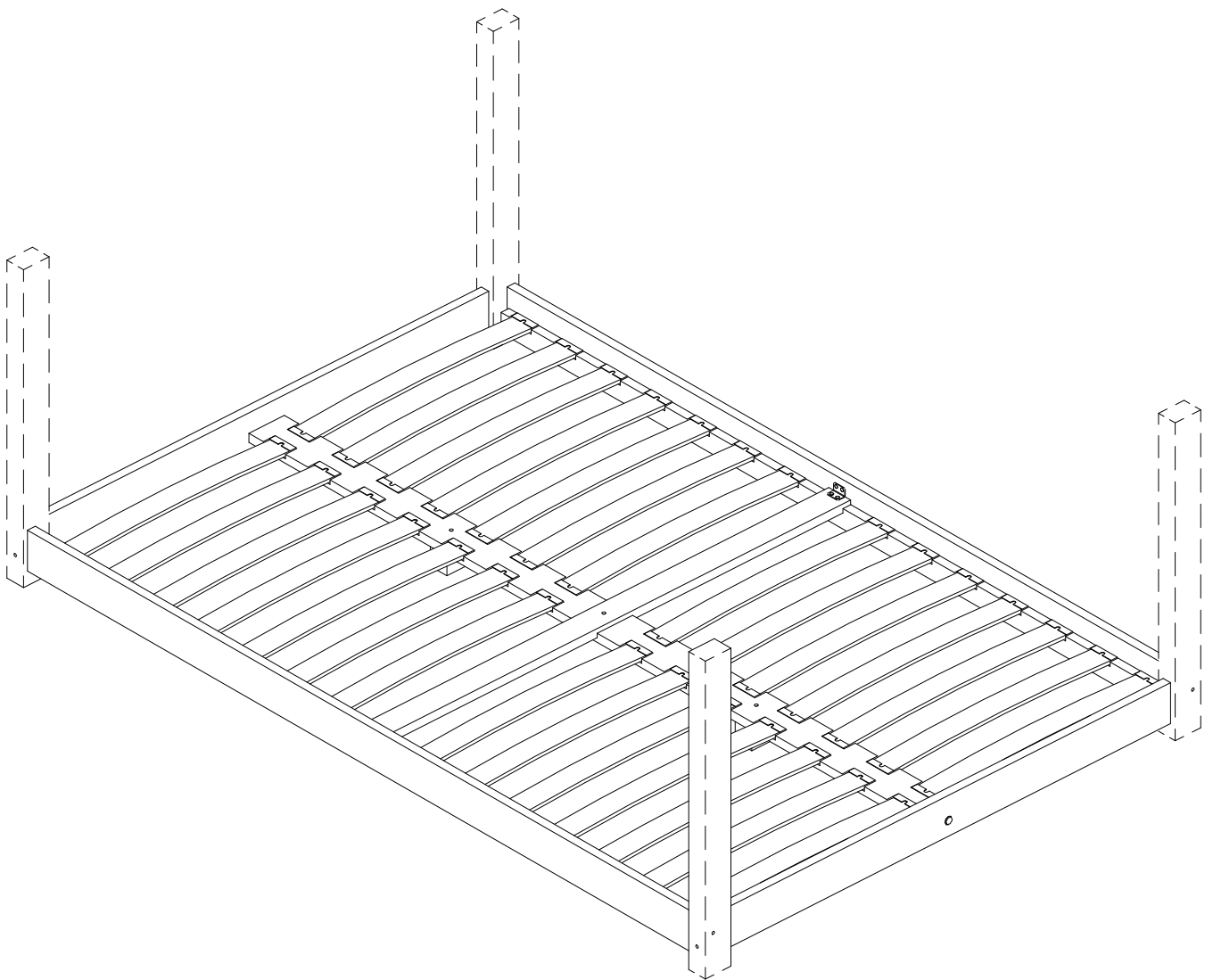

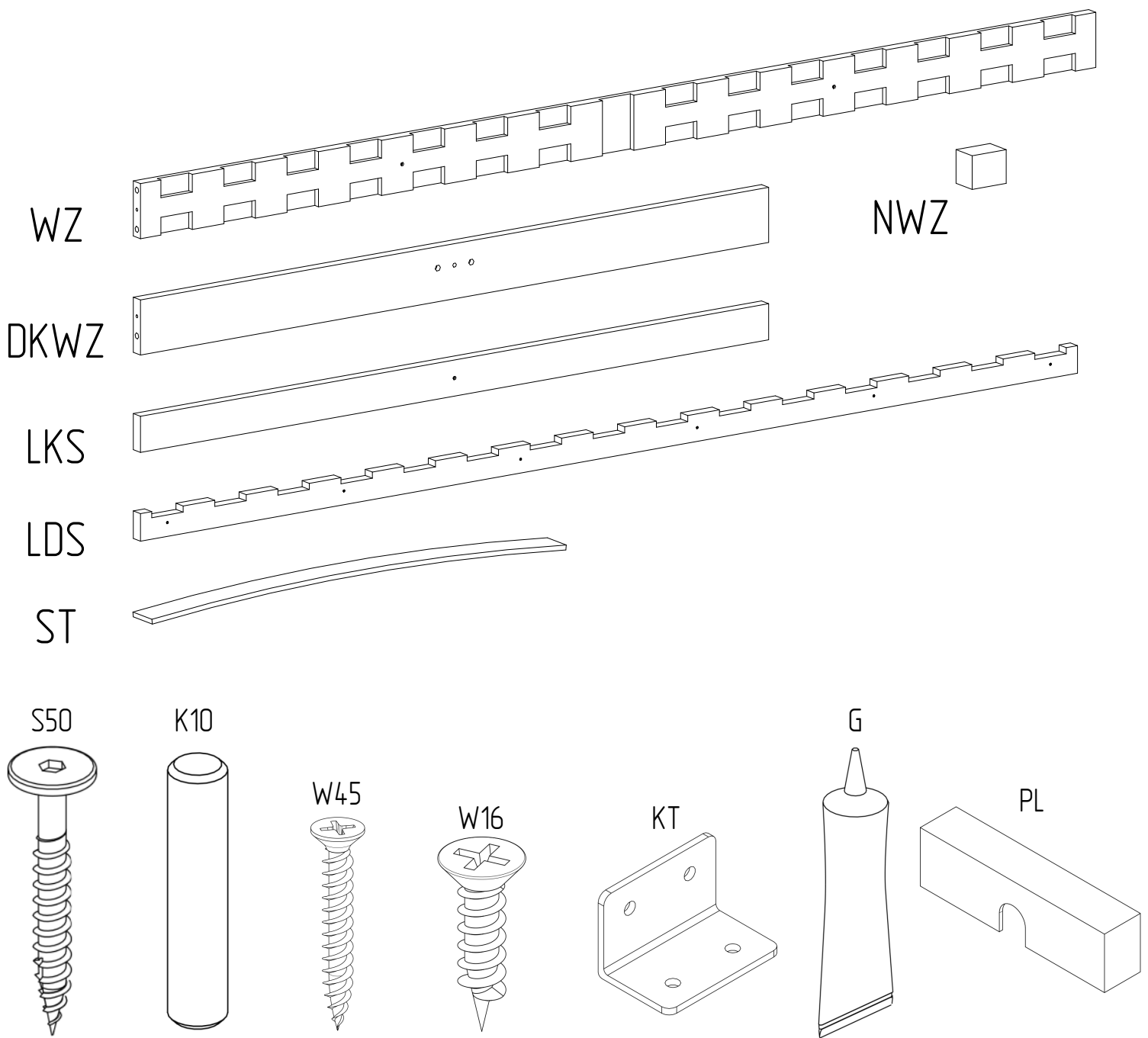

| ST                  |                |
|---------------------|----------------|
| DŁUGOŚĆ/LENGTH [cm] | ILOŚĆ/QUANTITY |
| 180                 | 28             |
| 190                 | 32             |
| 200                 | 32             |

| PL                  |                |
|---------------------|----------------|
| DŁUGOŚĆ/LENGTH [cm] | ILOŚĆ/QUANTITY |
| 180                 | 56             |
| 190                 | 64             |
| 200                 | 64             |

| CZĘŚĆ/PART     | WZ | DKWZ | NWZ | LKS | LDS | S50 | K10 | W45 | W16 | KT |
|----------------|----|------|-----|-----|-----|-----|-----|-----|-----|----|
| ILOŚĆ/QUANTITY | 1  | 2    | 3   | 1   | 2   | 2   | 4   | 3   | 8   | 2  |

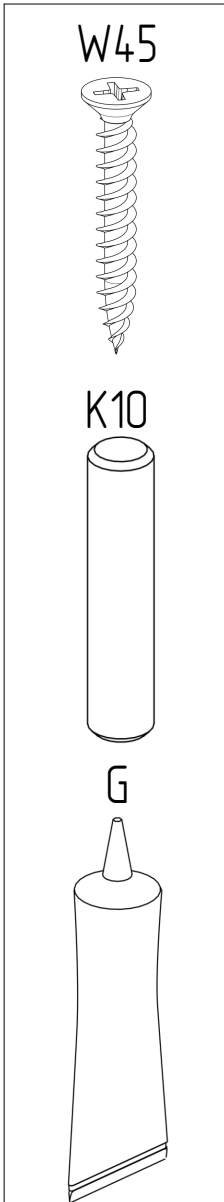
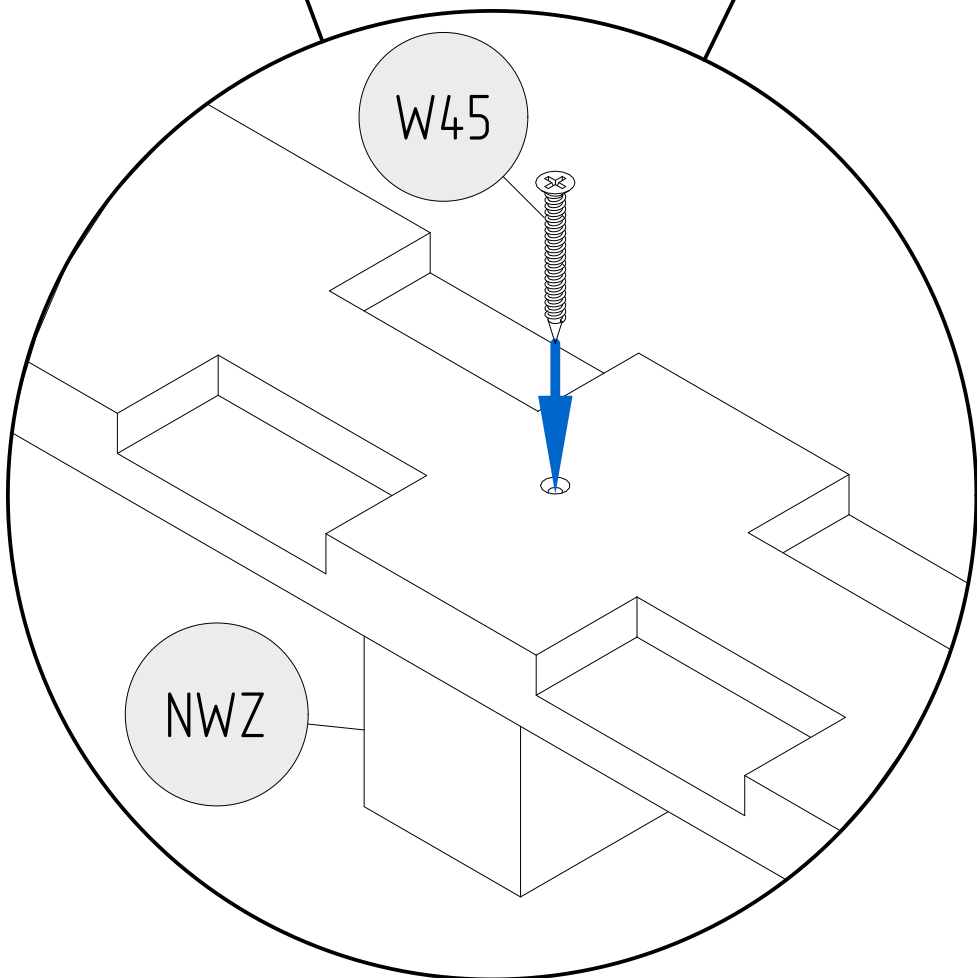
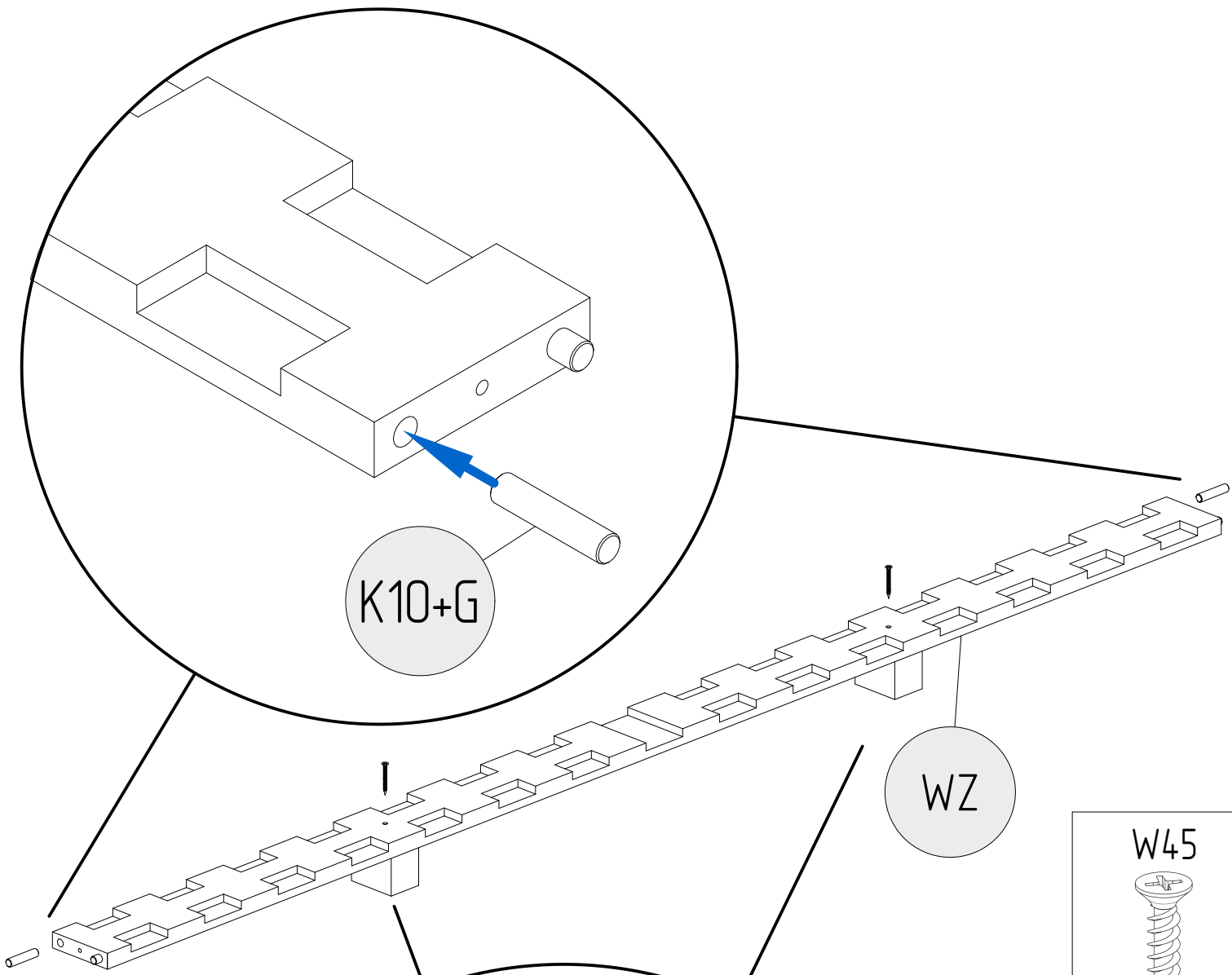

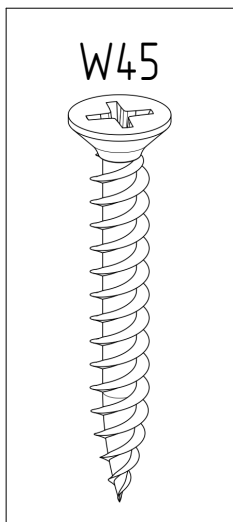
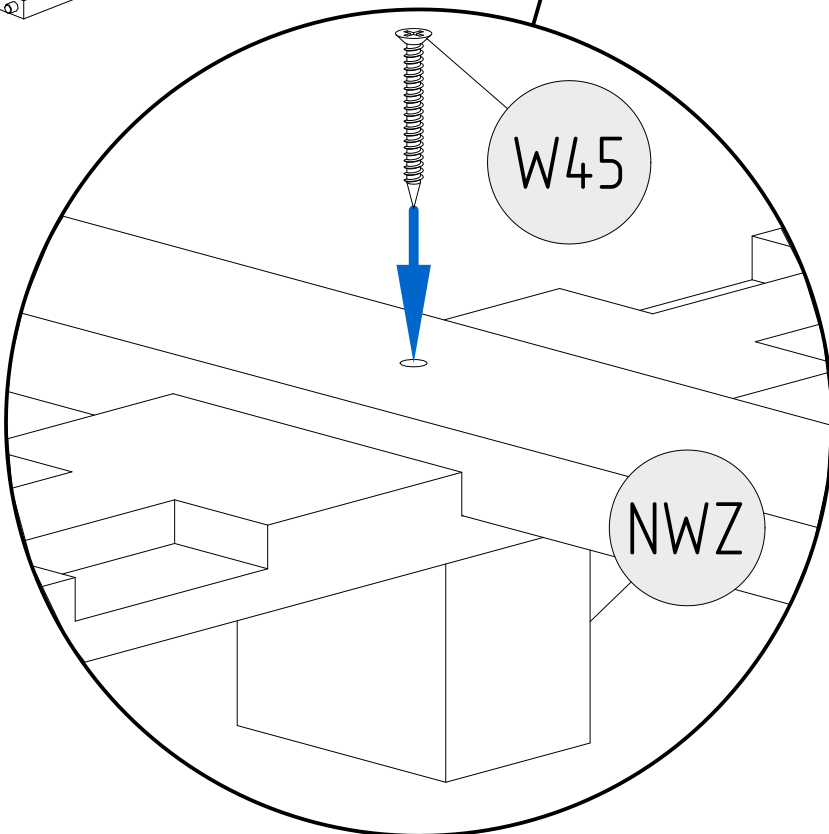
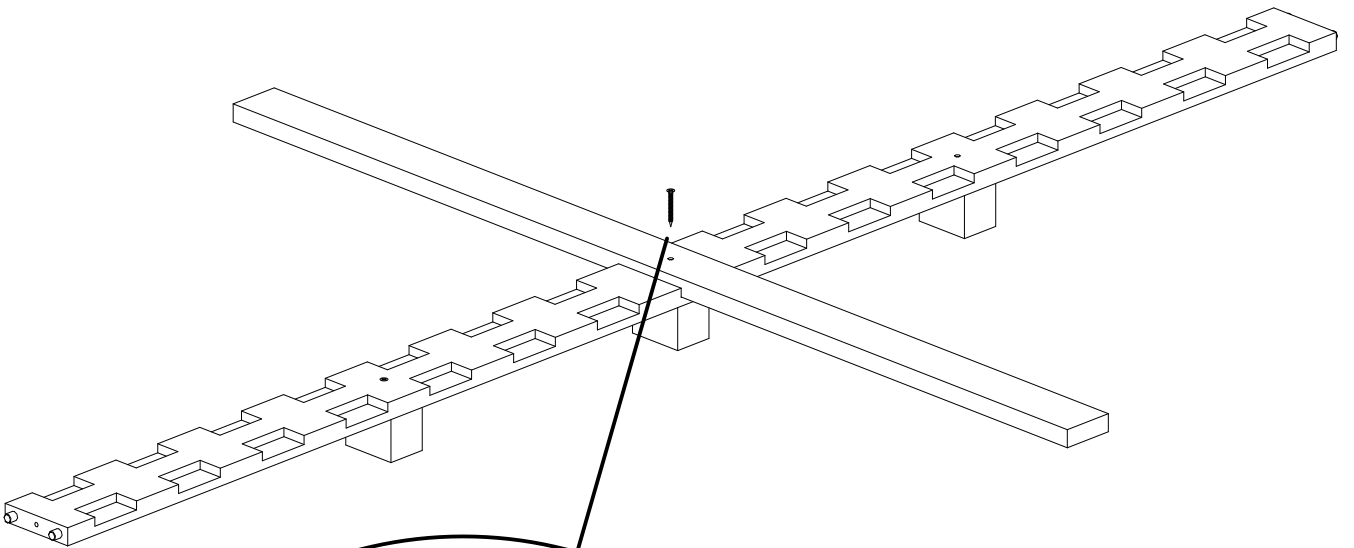
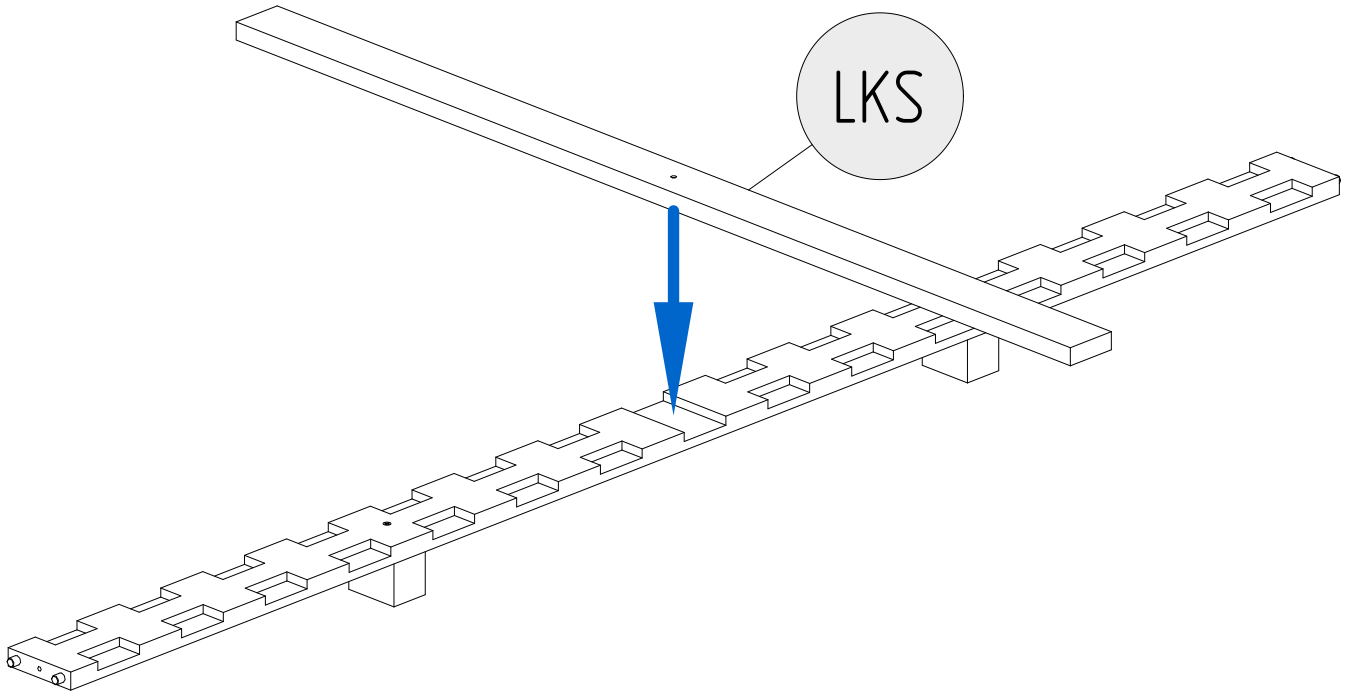

TO PROPERLY SCREW DOWN THE BED LEG, SEE  
THE FIRST PART OF THE MANUAL

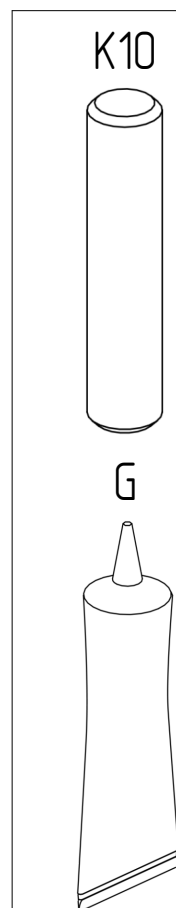
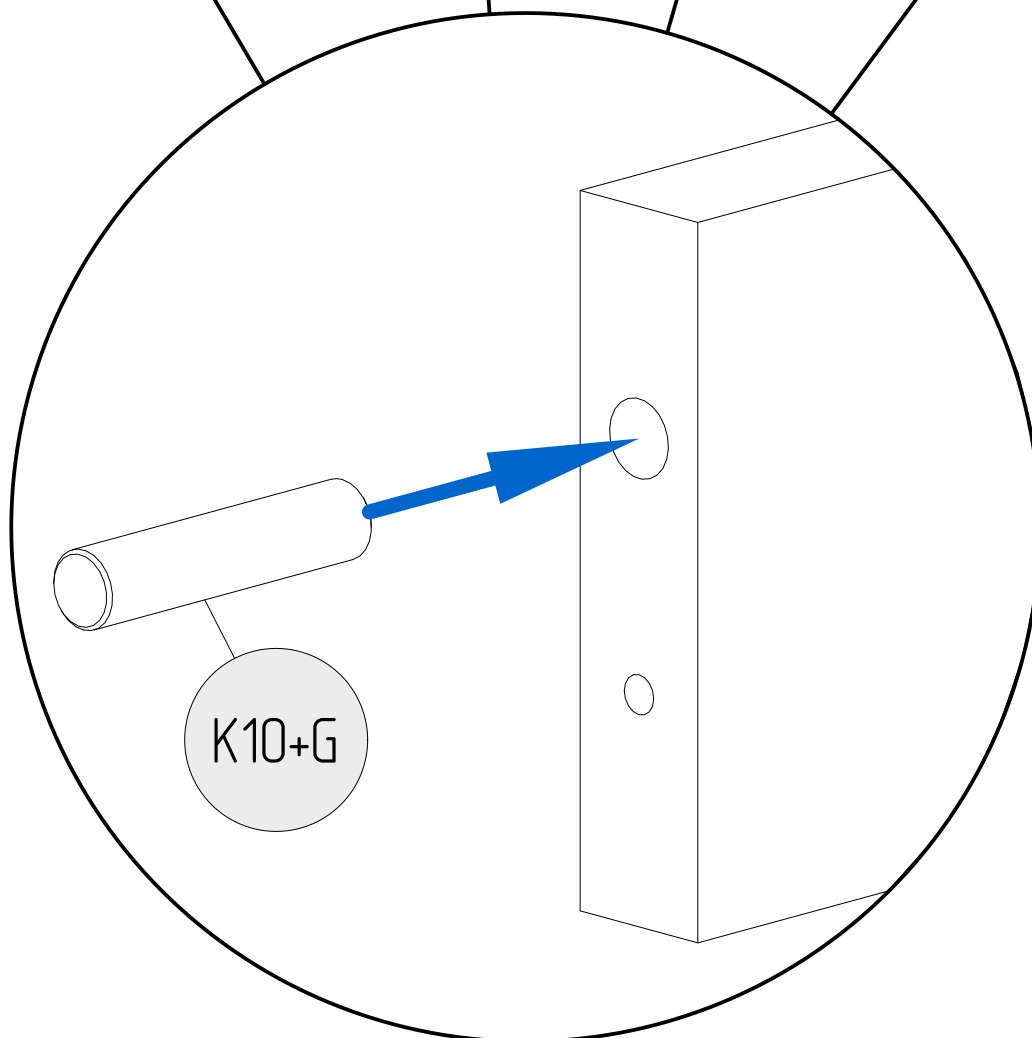
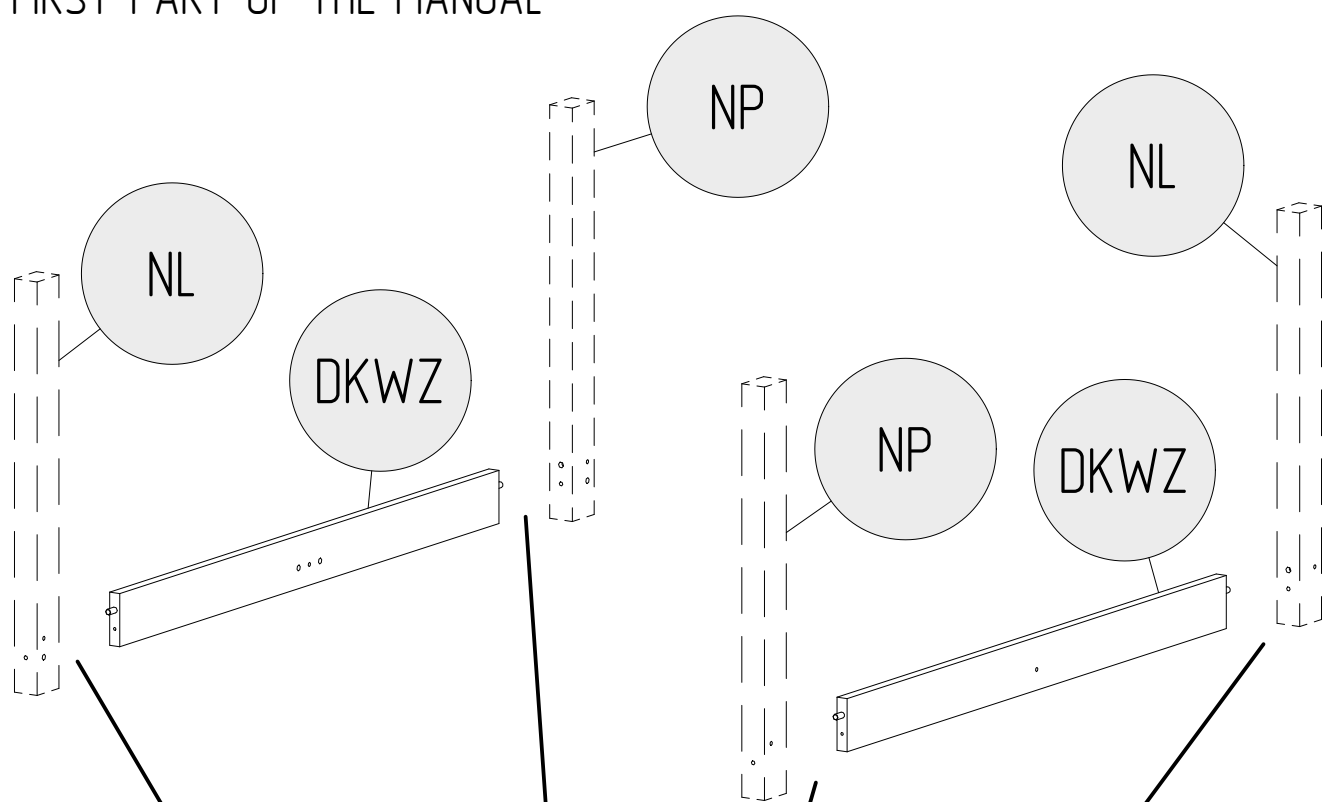



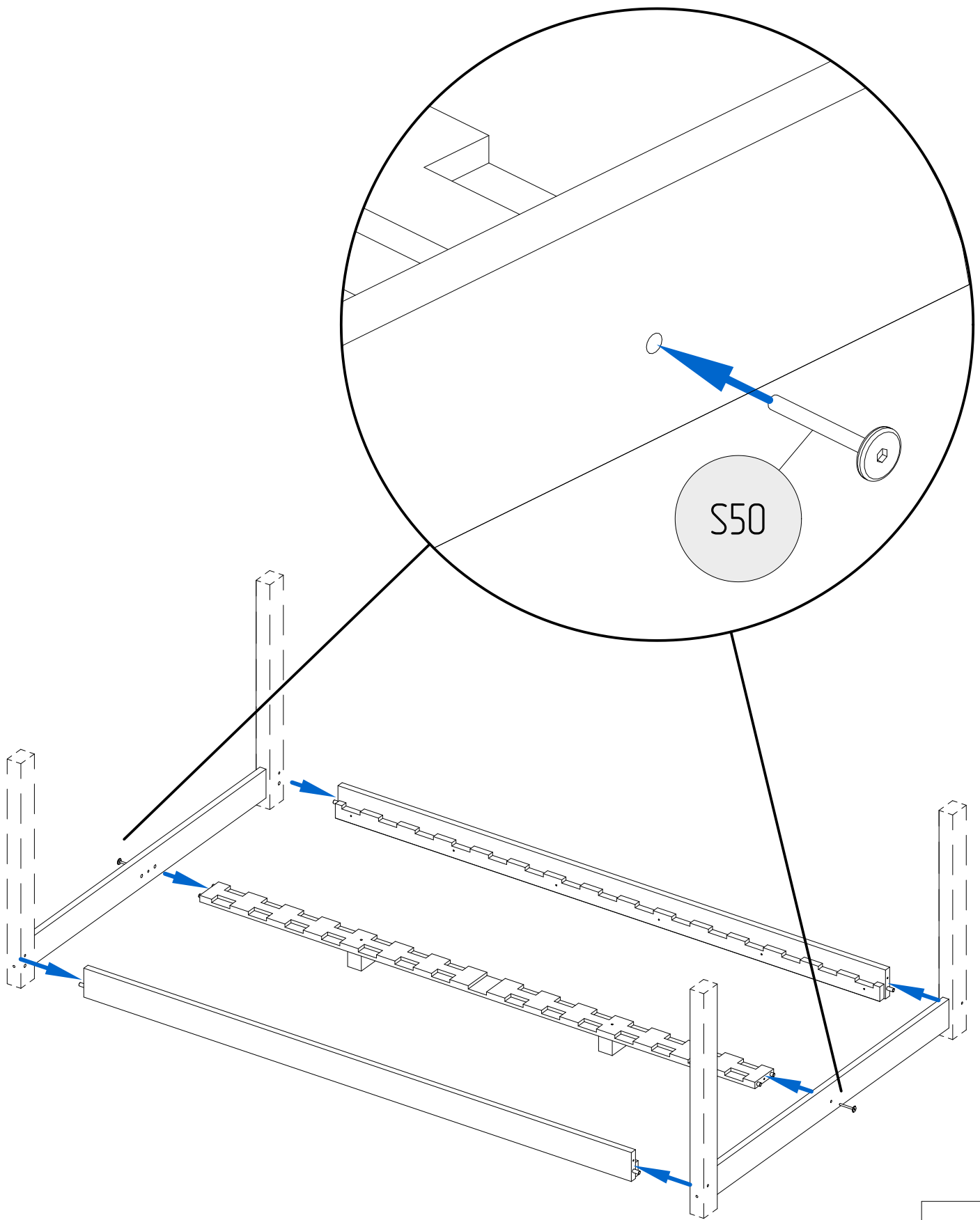

TO INSTALL ALL THE ELEMENTS CORRECTLY,  
PLEASE REFER TO THE FIRST PART OF MANUAL

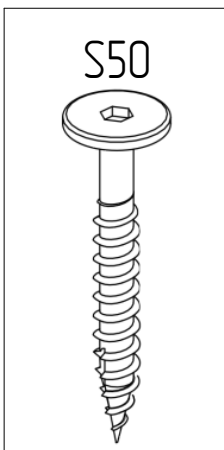

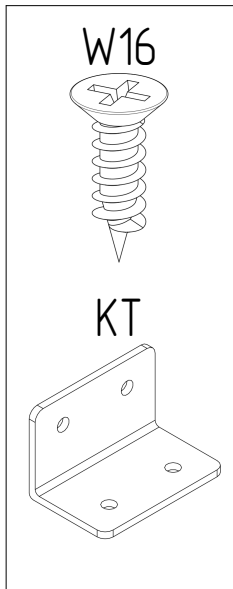
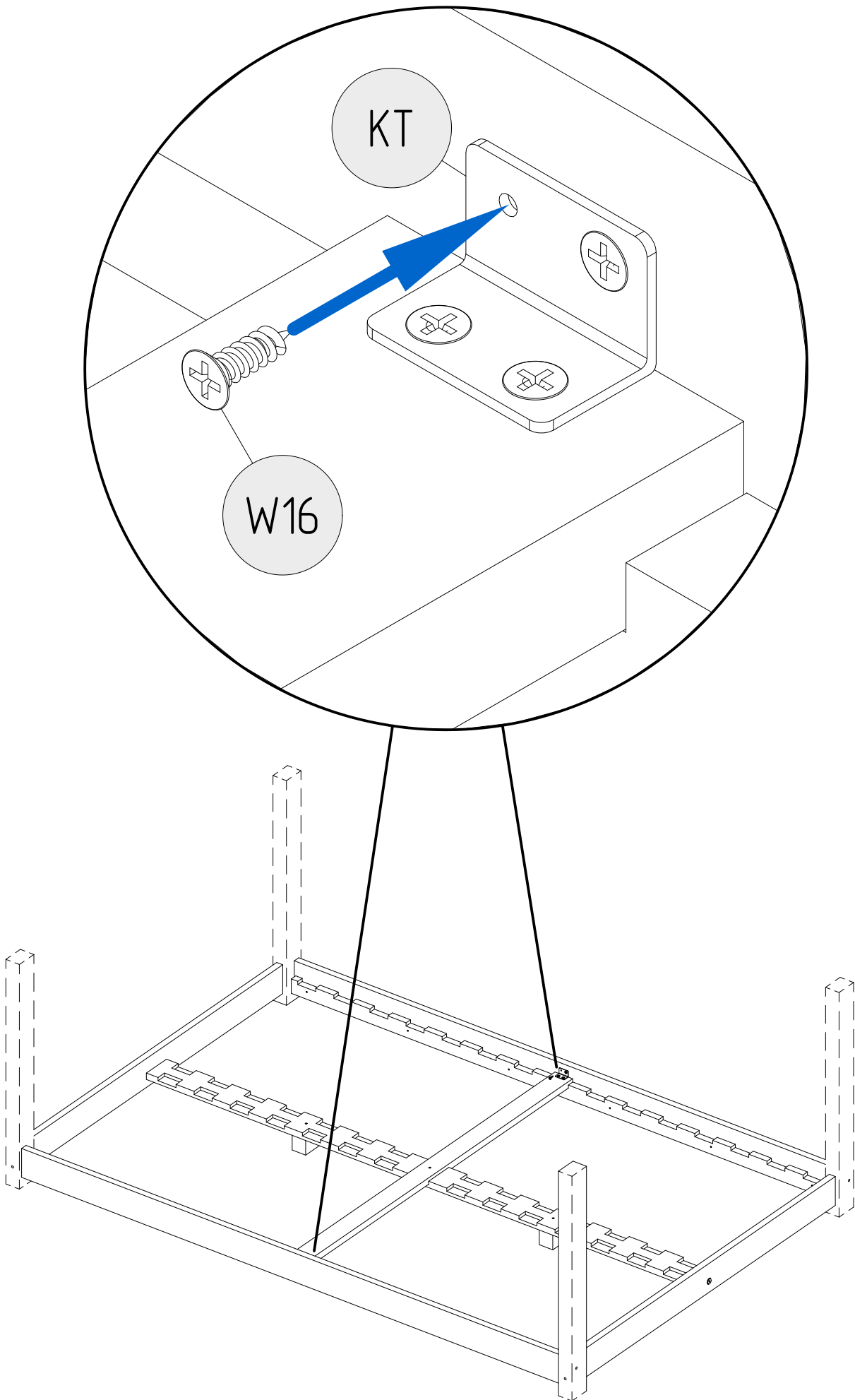

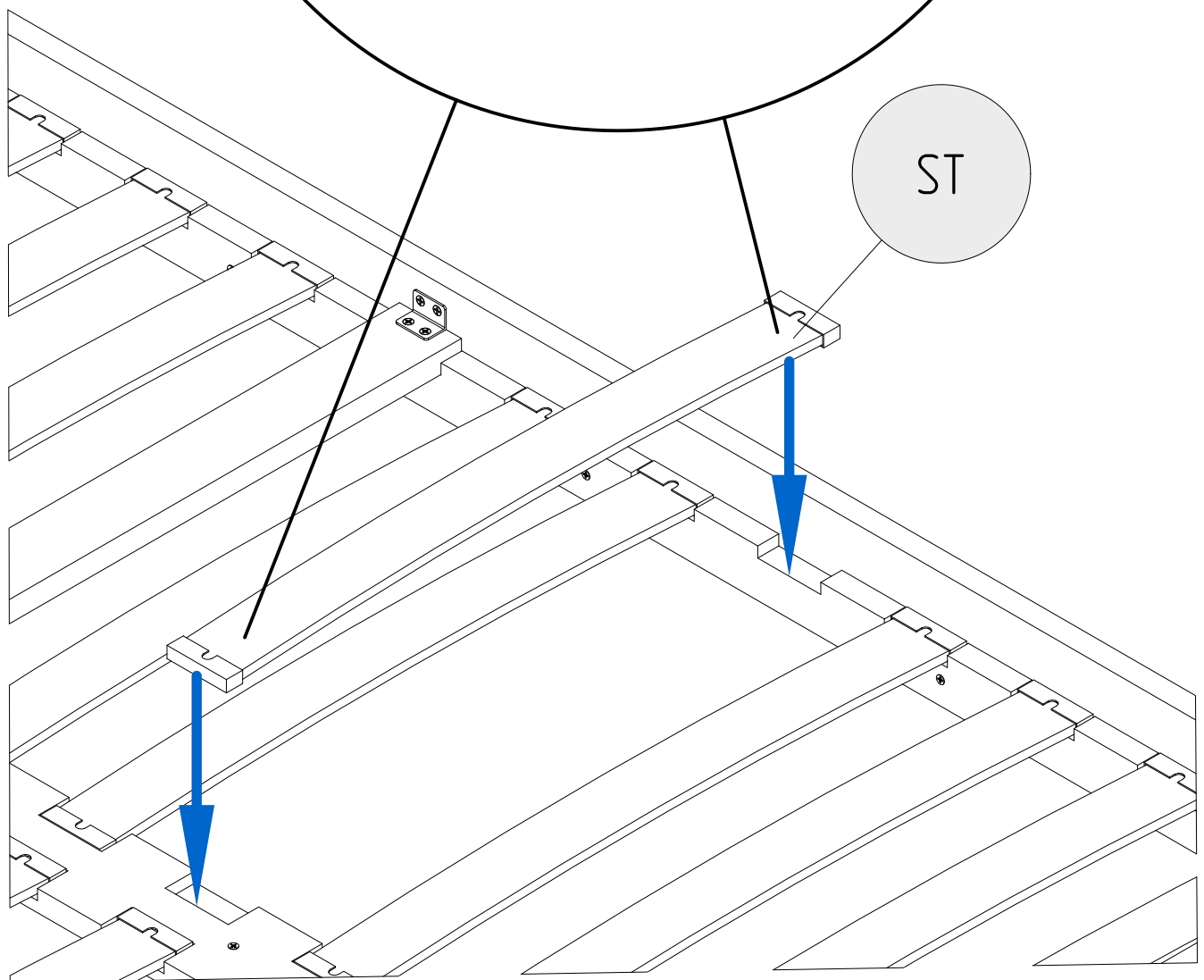
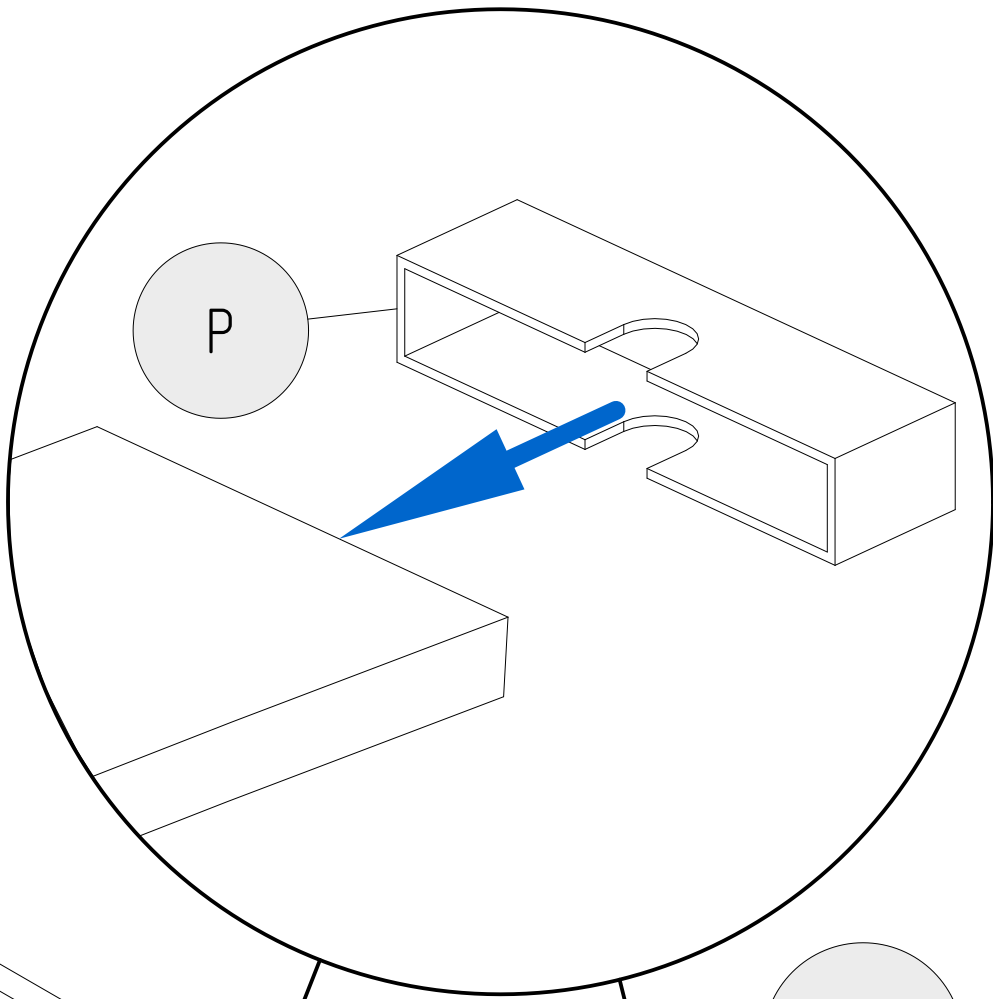
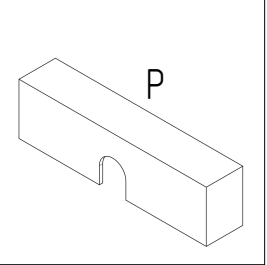

# UWAGA / WARNING

- Używać tylko materacy o grubości 8-16 cm
- Nie skakać na łóżku
- Nie wieszać się na elementach konstrukcyjnych
- Maksymalne obciążenie konstrukcji wynosi 100 kg

Części drewniane i plastikowe należy czyścić za pomocą suchej szmatki oraz zwykły, łagodnych środków do pielęgnacji i czyszczenia surowego drewna

- Use only mattress with thickness is 8-16 cm height
- Prohibit horseplay on or under bed(s)
- Do not hang on construction components
- The maximum load of the structure is 100 kg

Wooden and plastic should be cleaned with a dry cloth and ordinary, mild care and cleaning of raw wood