

ASCENT™ LINEAR SERIES 36-1 DIRECT VENT GAS FIREPLACE



Specifications

Model	BTU	Width		Height		Depth		Viewing Area
		Actual	Framing	Actual	Framing	Actual	Framing	
BL36-1	17,500 (NG) 16,000 (P)	35 15/16	36 1/2	39 1/16	39 3/8	15 3/4	16	16 3/4 x 30 3/4

Front Options

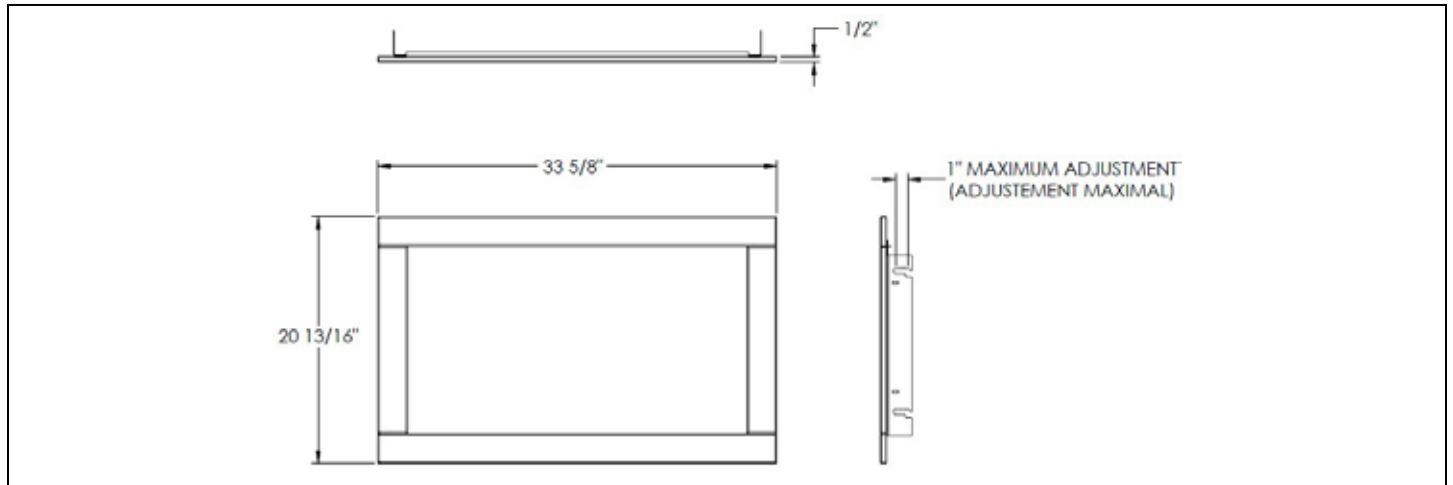

Framing

⚠ WARNING

- Do not build into this area - it must be left clear to provide adequate clearance for the vent in this 14" (35.6cm) wide area centered along the front of the appliance. The appliance should be in its final location before framing.

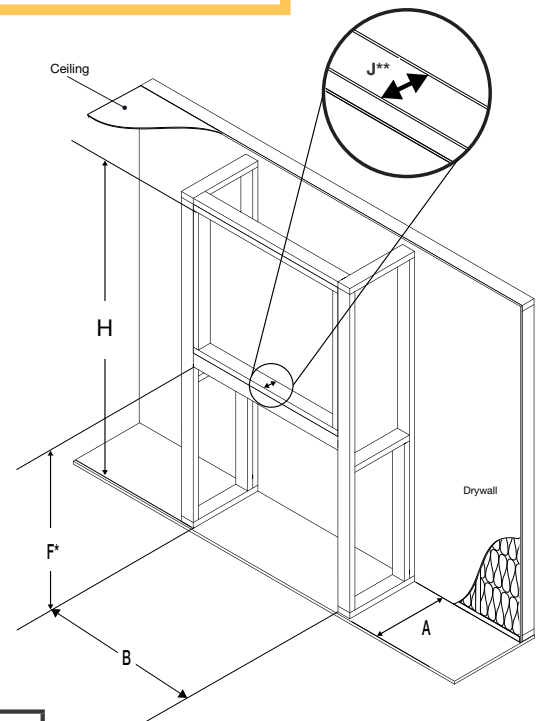
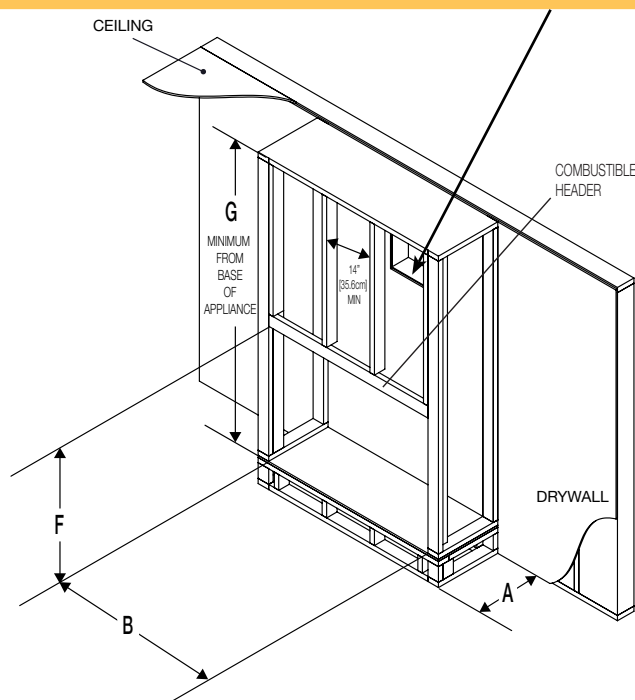

B	36 1/2" (92.7cm)
F	39 3/8" (100cm)
A	16" (40.6cm)
G	56" (142.2cm)

H	84" (213cm)
J	3 1/2" (89cm)

* Allow for finished floor and hearth thickness when setting these dimensions.

** 2" x 4" frame can be "backed" with 3/4" ply to support TV mounting hardware.

ASCENT™ LINEAR SERIES 36-1 DIRECT VENT GAS FIREPLACE



Product information provided is not complete and is subject to change without notice. Please consult the installation manual for the most up to date installation information.

Dimensions

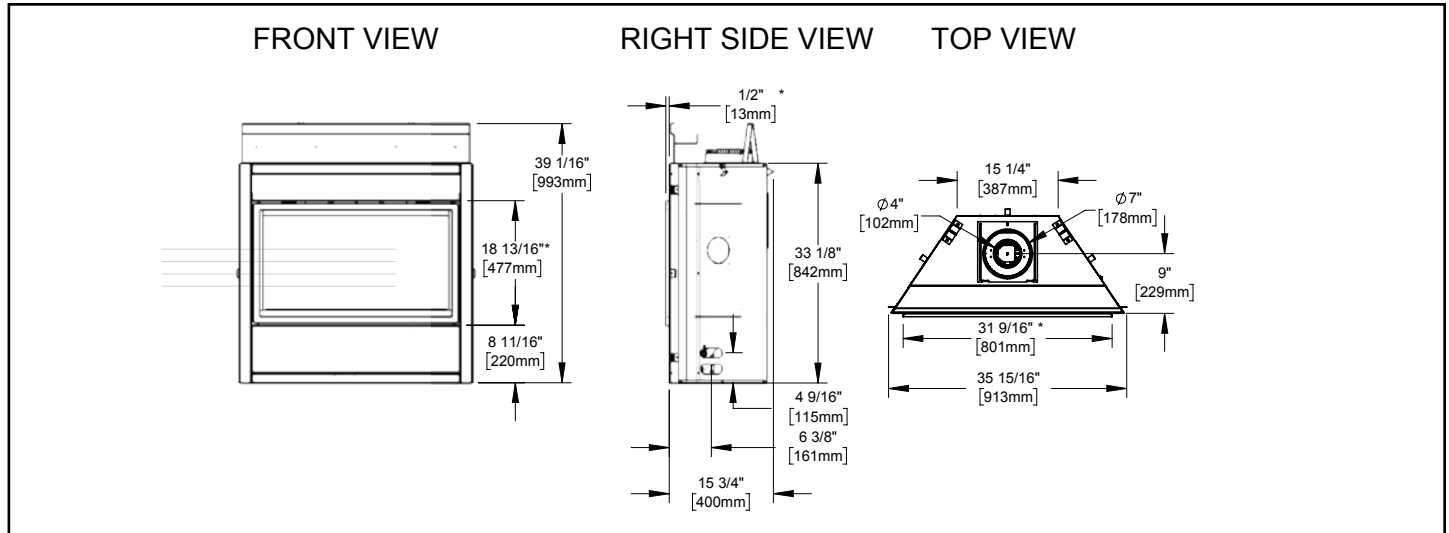

Wall Penetration

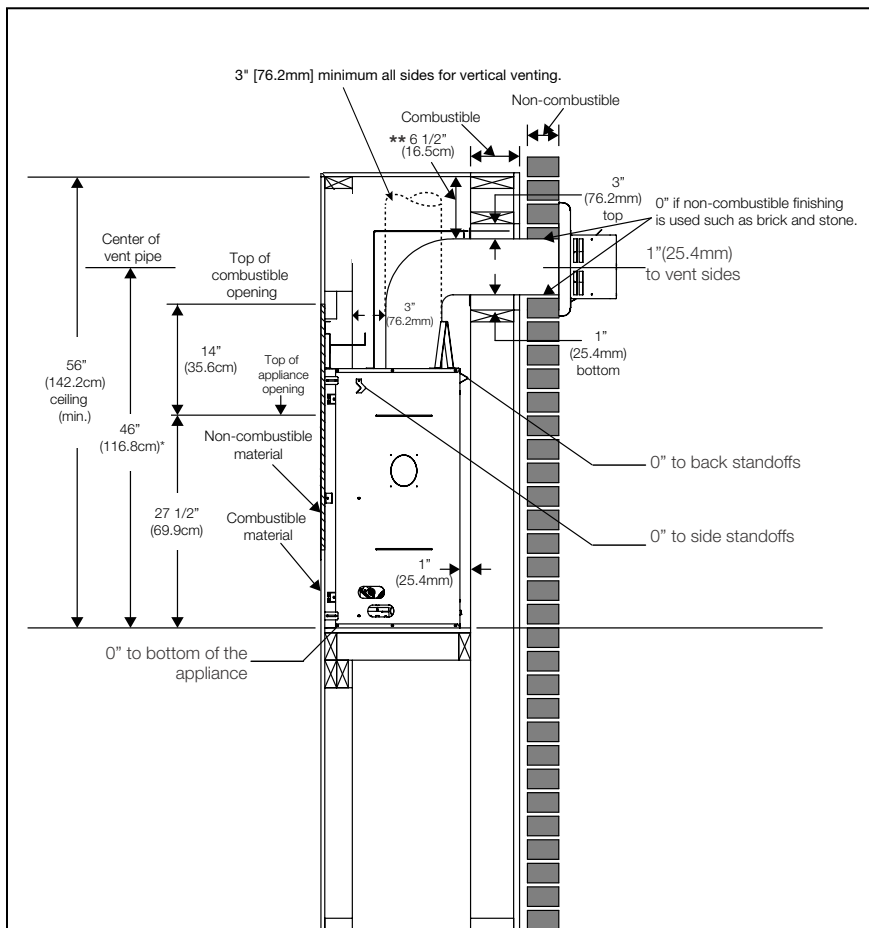

note:
The vent shield is telescopic and must be adjusted to shield the full depth of the combustible wall penetration.

* See "venting requirements" and "venting installation" sections.

** Clearances within the enclosure may be higher, see "minimum framing dimensions" section.

Combustible Mantel Clearances

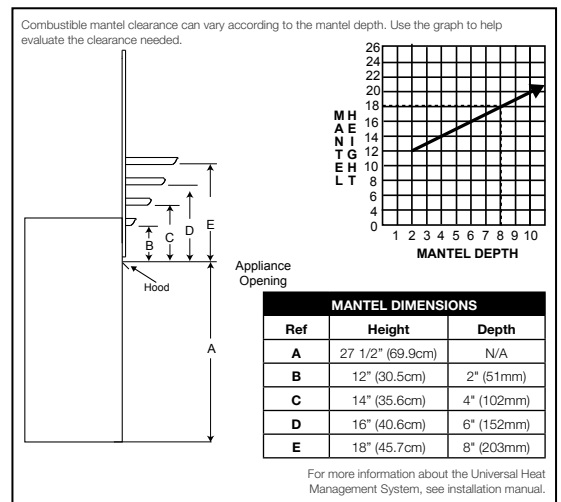

Appliance Location

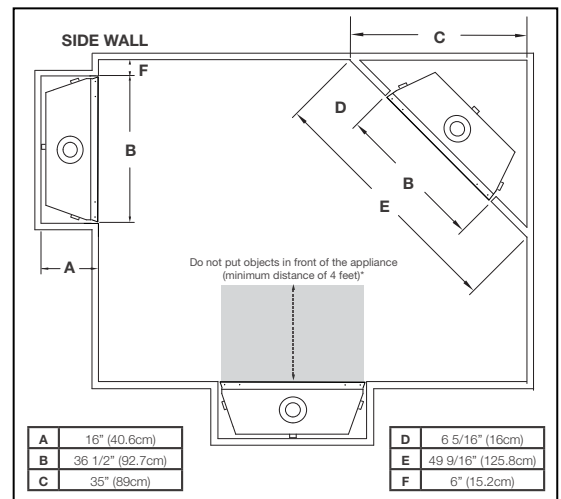

W415-3130 / 10.07.22

Spécifications

Modèle	BTU	Largeur		Hauteur		Profondeur		Dimensions de Vision
		Réel	Ossature	Réel	Ossature	Réel	Ossature	
BL36-1	17,500 (NG) 16,000 (P)	35 15/16	36 1/2	39 1/16	39 3/8	15 3/4	16	16 3/4 x 30 3/4

Options de Façade

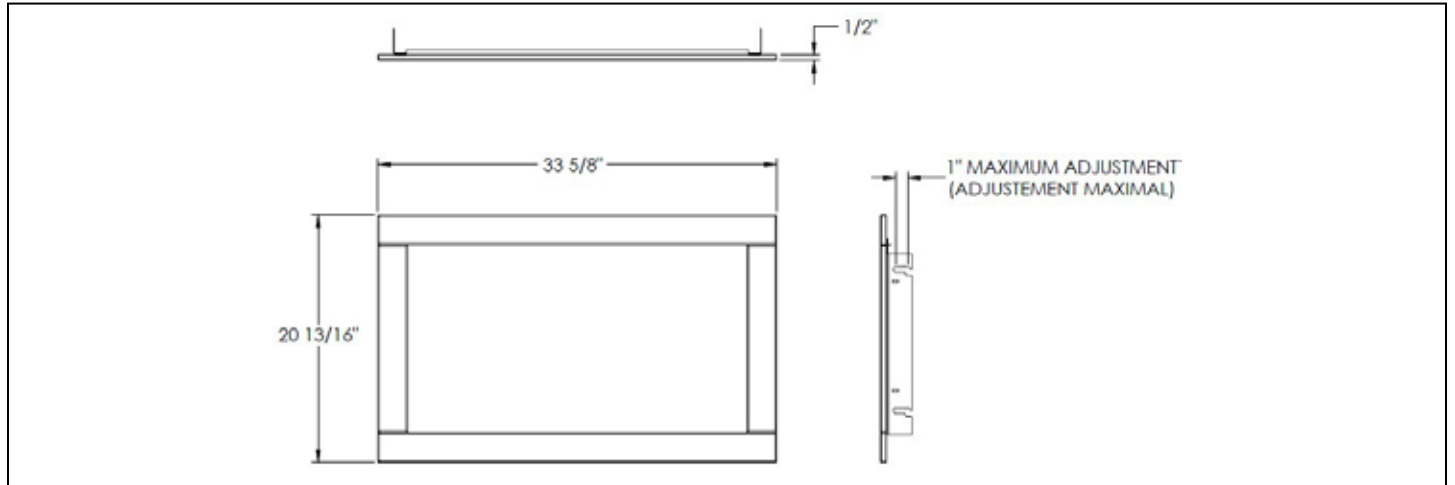

Ossature

⚠ AVERTISSEMENT

- Ne construisez pas dans cette zone - elle doit être dégagée pour fournir un dégagement suffisant pour l'évent dans cette zone de 14 po (35,6 cm) de large centrée le long de l'avant de l'appareil. L'appareil doit être à son emplacement définitif avant l'encadrement.

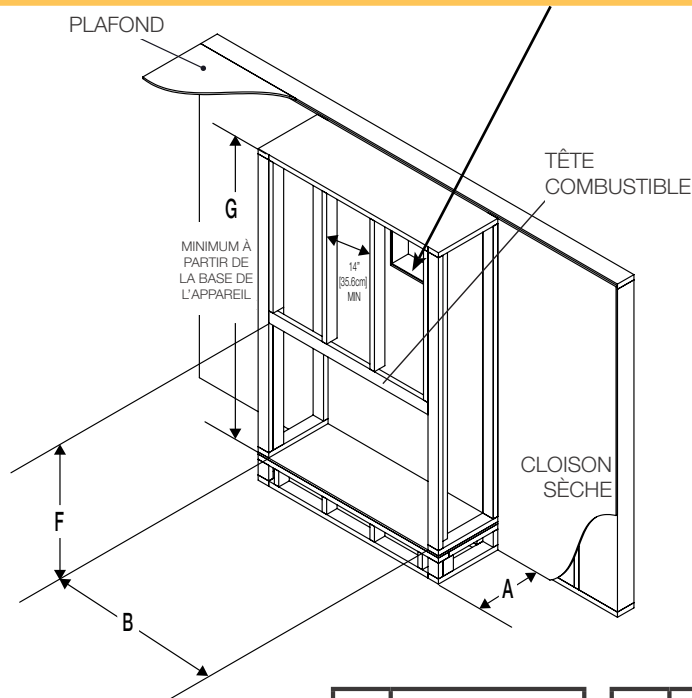

B	36 1/2" (92.7cm)
F	39 3/8" (100cm)
A	16" (40.6cm)
G	56" (142.2cm)

H	84" (213cm)
J	3 1/2" (89cm)

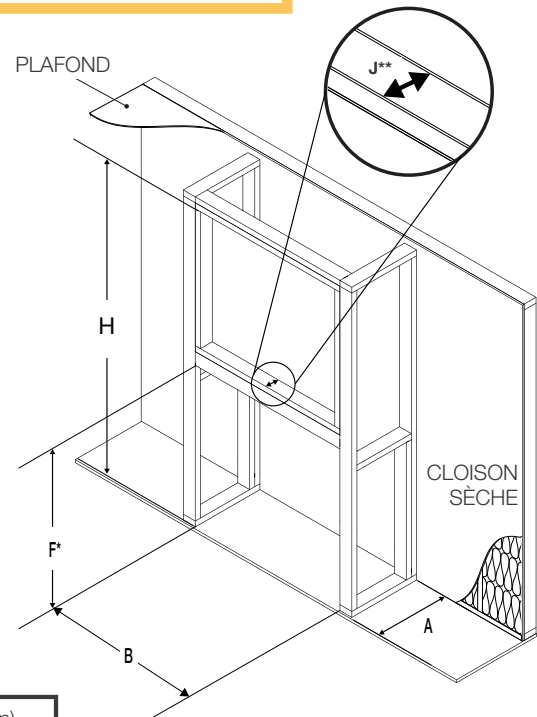

- * Tenez compte de l'épaisseur du sol fini et de l'âtre lors du réglage de ces dimensions.
- ** Le cadre de 2" x 4" peut être "soutenu" avec un pli de 3/4" pour supporter le matériel de montage du téléviseur.

FOYER À GAZ VENTILÉ DIRECTE SÉRIES ASCENT^{MD} LINÉAIRE 36-1



Les informations sur les produits fournies ne sont pas complètes et peuvent être modifiées sans préavis. Veuillez consulter le manuel d'installation pour obtenir les informations d'installation les plus récentes.

Dimensions

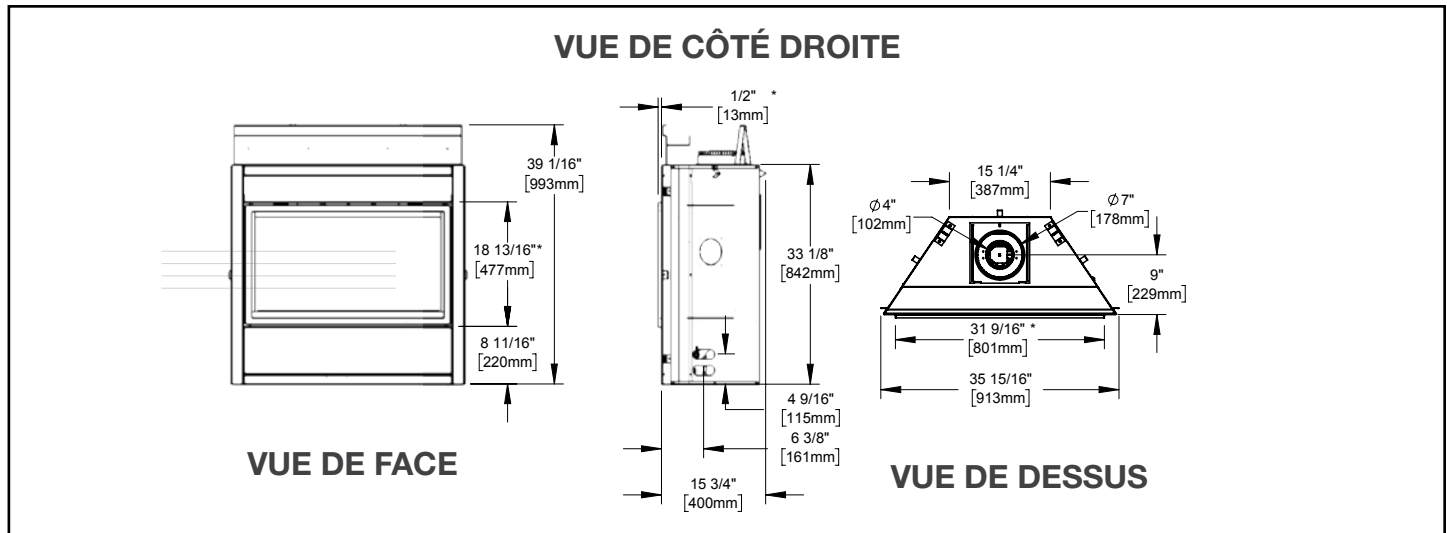

Pénétration de Mur

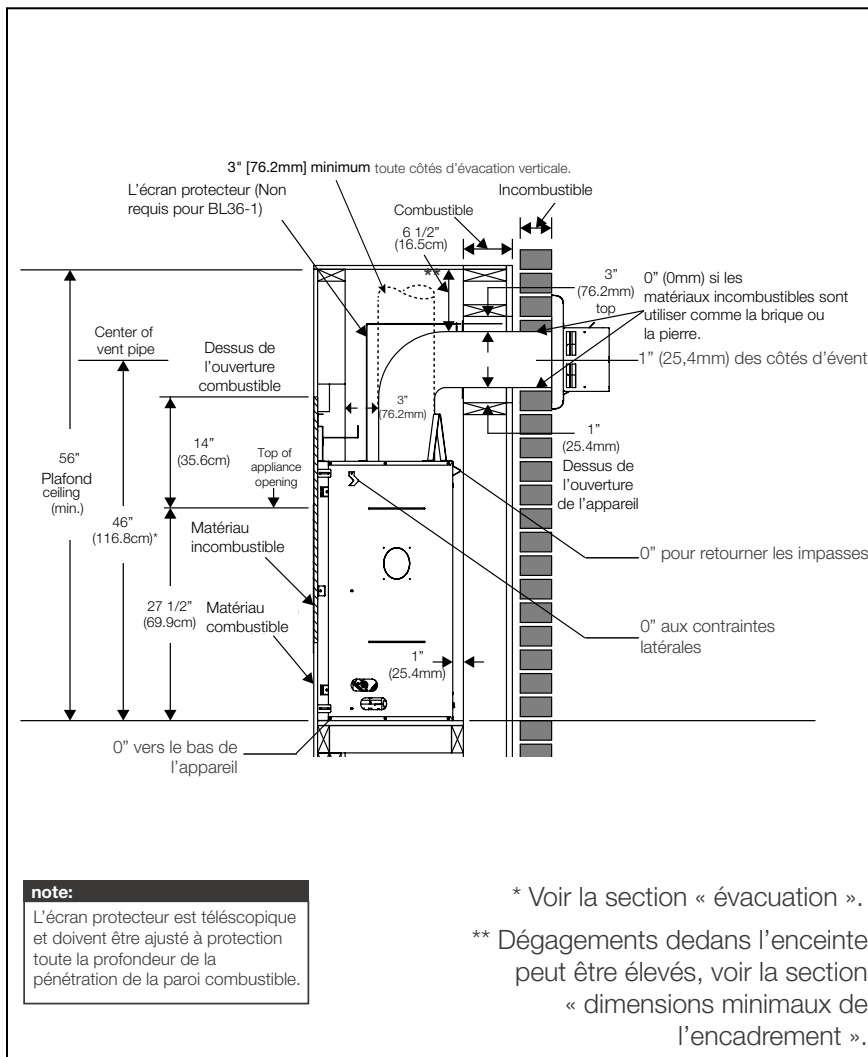

Dégagements de Tablette Combustible

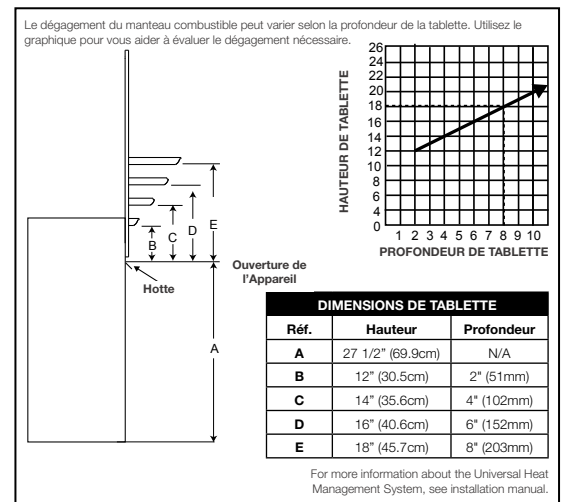

Emplacement de l'Appareil

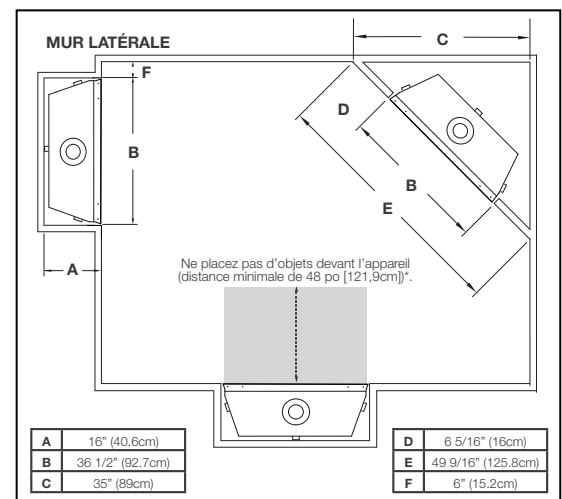

W415-3130 / 10.07.22

ASCENT™ LINEAR SERIES 42 DIRECT VENT GAS FIREPLACE



Specifications

Model	BTU	Width		Height		Depth		Glass
		Actual	Framing	Actual	Framing	Actual	Framing	
BL42	20,000	42	42 1/2	38 3/16	39 3/8	18 5/16	18 9/16	37 1/2 x 16 3/4

Dimensions

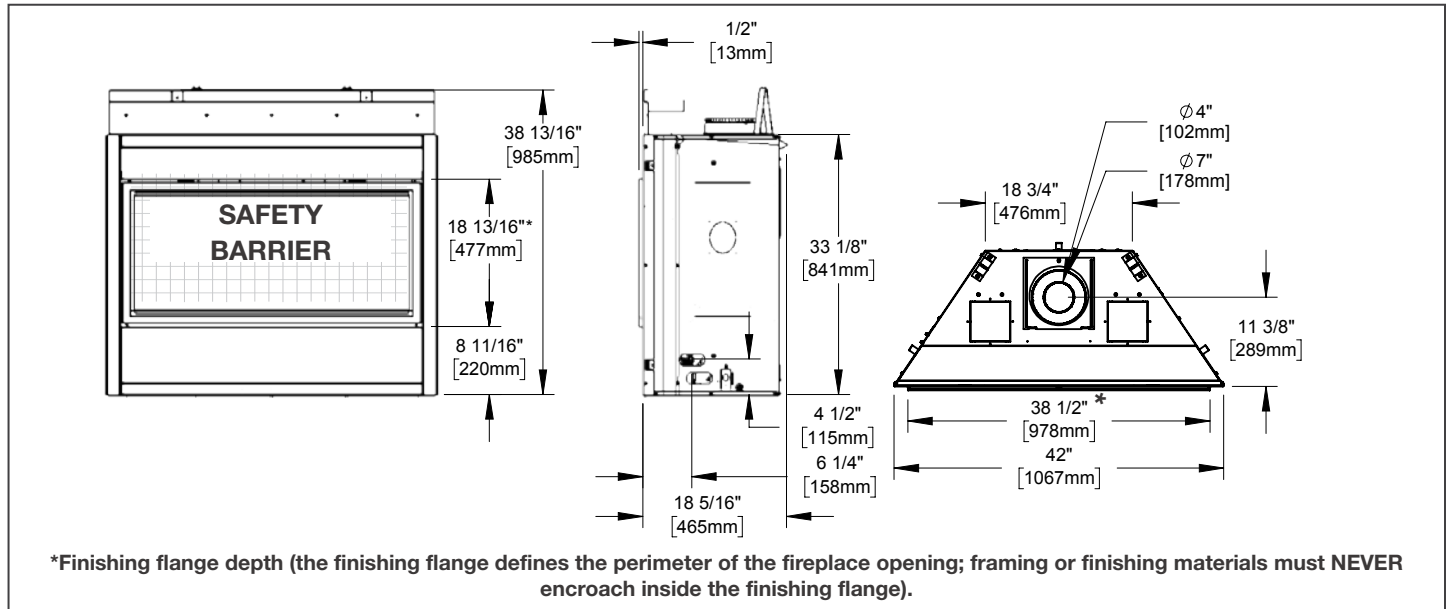

Appliance Location

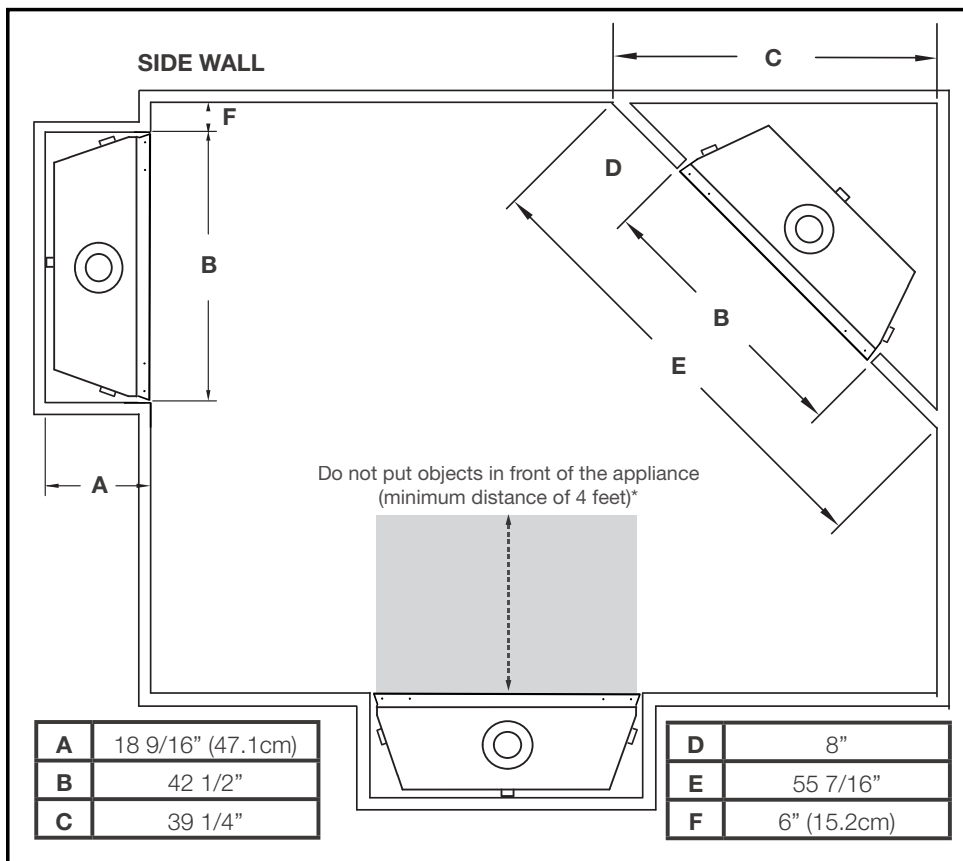

Combustible Mantel Clearances

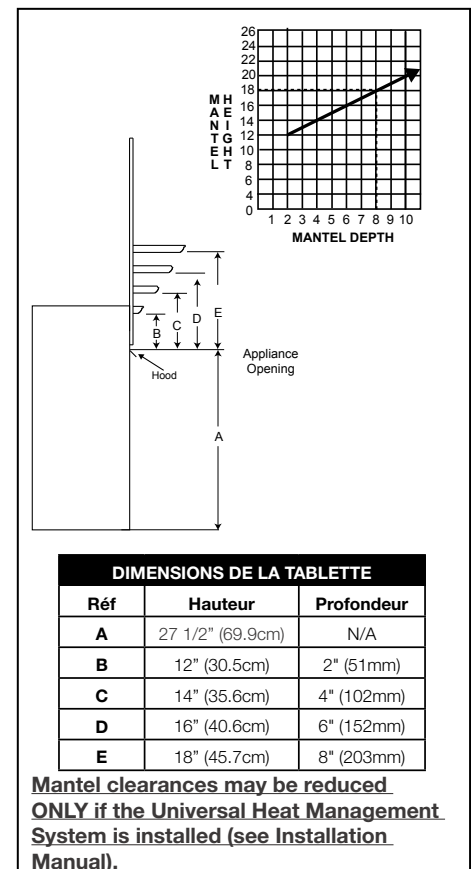

W415-3065 / A / 10.07.22

ASCENT™ LINEAR SERIES 42 DIRECT VENT GAS FIREPLACE



Product information provided is not complete and is subject to change without notice. Please consult the installation manual for the most up to date installation information.

Wall Penetration

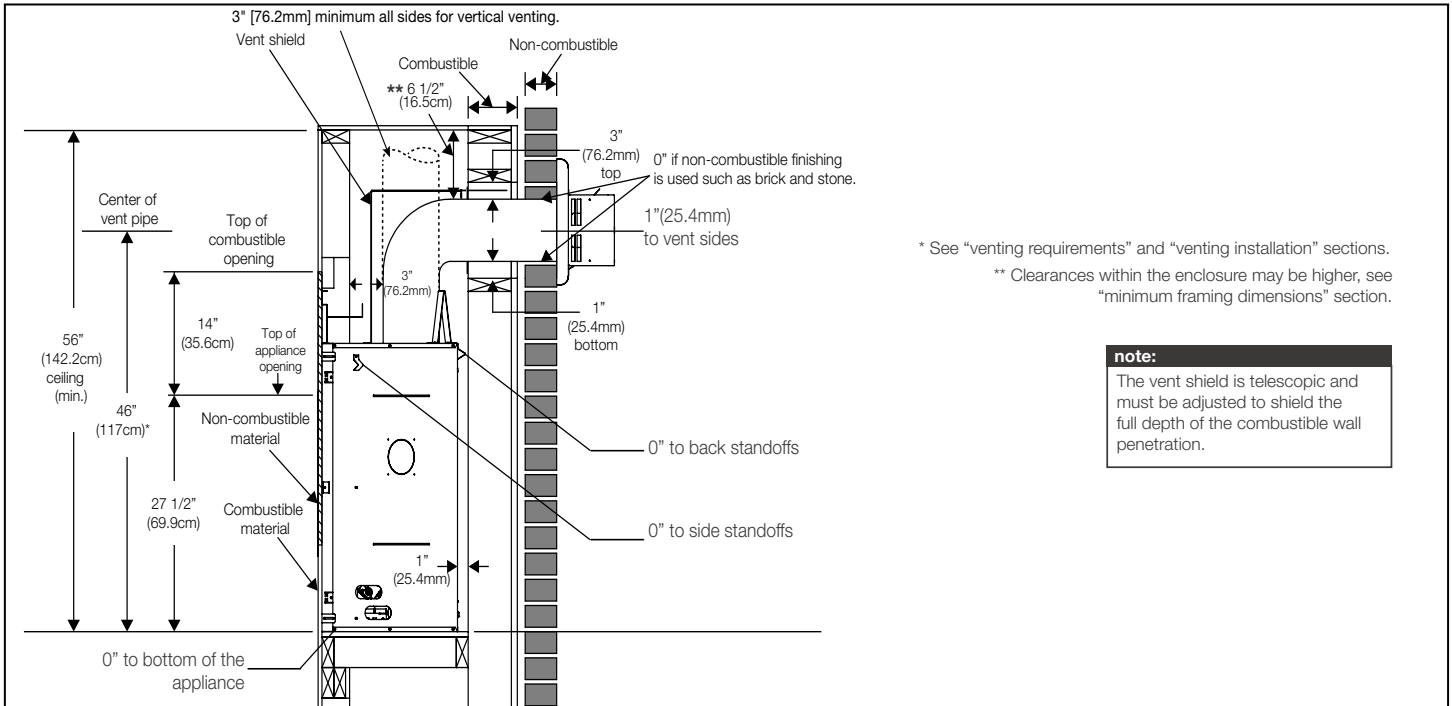

Framing

WARNING

- Do not build into this area - it must be left clear to provide adequate clearance for the vent in this 14" (35.6cm) wide area centered along the front of the appliance. The appliance should be in its final location before framing.

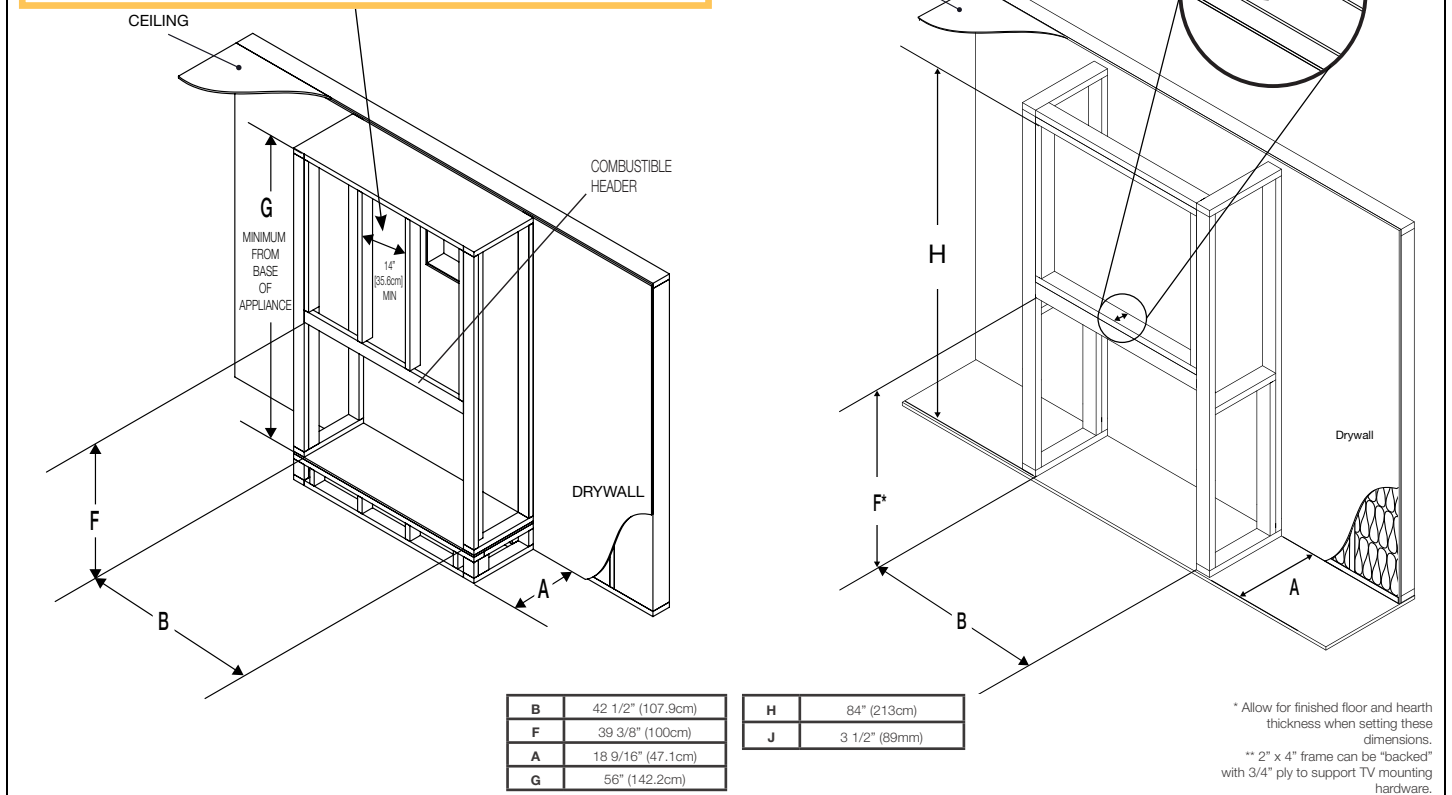

W415-3065 / A / 10.07.22

Spécifications

Modèle	BTU	Largeur		Hauteur		Profondeur		Verre
		Réel	Ossature	Réel	Ossature	Réel	Ossature	
BL42	20 000	42	42 1/2	38 3/16	39 3/8	18 5/16	18 9/16	37 1/2 x 16 3/4

Dimensions

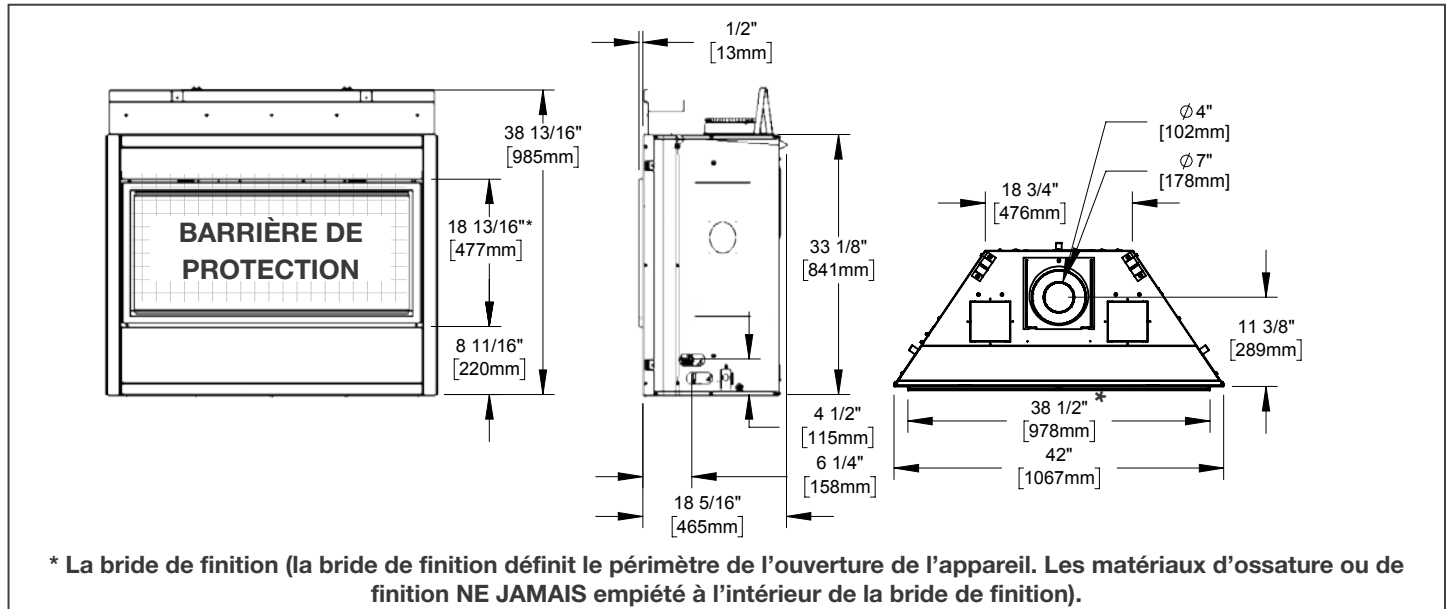

Emplacement de l'appareil

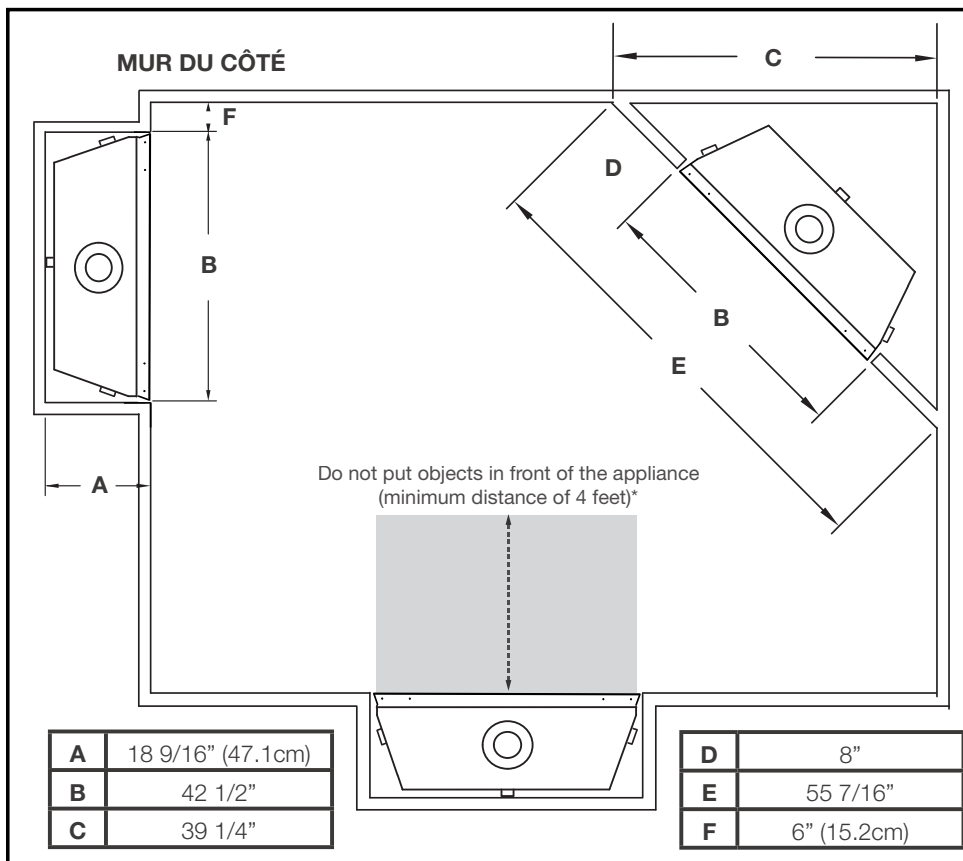

Dégagements Combustibles de la Tablette

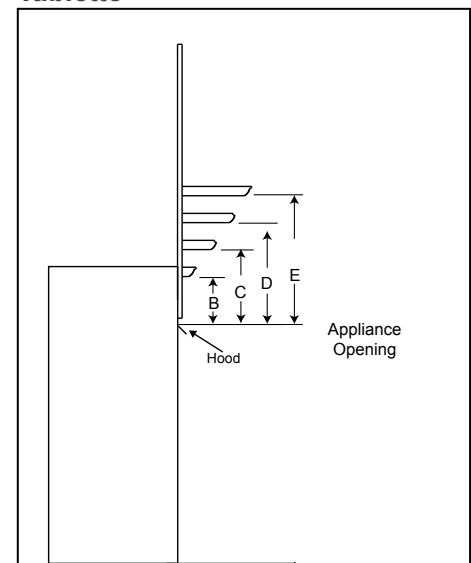

DIMENSIONS DE TABLETTE		
Réf	Hauteur	Profondeur
B	12" (30.5cm)	2" (51mm)
C	14" (35.6cm)	4" (102mm)
D	16" (40.6cm)	6" (152mm)
E	18" (45.7cm)	8" (203mm)

Les dégagements de la tablette peuvent être réduites SEULEMENT si la système de gestion de chaleur universelle est installée (voir la manuel d'installation).

FOYER À GAZ VENTILÉ DIRECTE SÉRIES ASCENT^{MD} LINÉAIRE 42



L'information du produit fourni n'est pas complet et est sujet de changer sans préavis. Consultez le manuel d'installation pour plus d'information d'installation actuel.

Pénétration du Mur

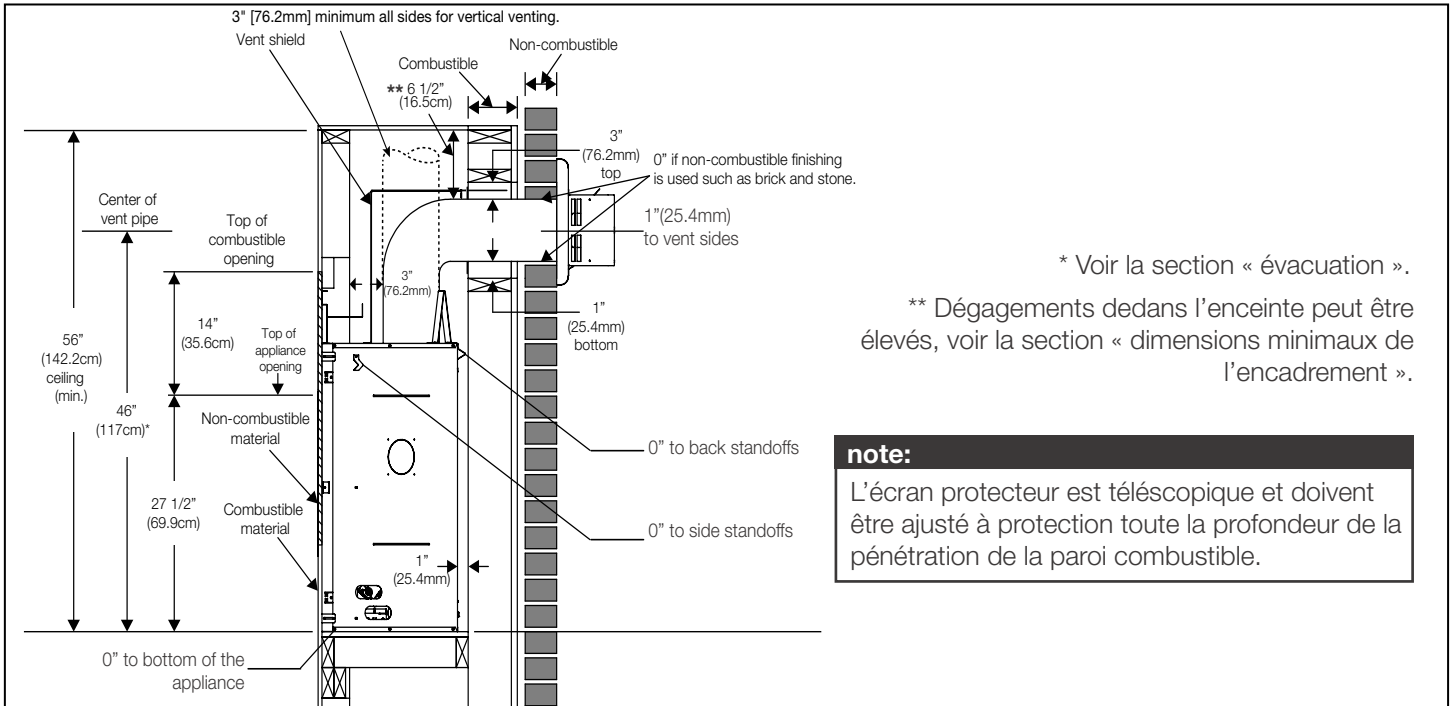

Ossature

⚠ AVERTISSEMENT

- Ne construisez pas dans cet espace de 14" (35,6cm) de largeur, centré le long de l'avant de l'appareil. Cet espace doit resté libre afin d'offrir un dégagement adéquat pour l'évacuation. Aucun matériaux combustible n'est permis.

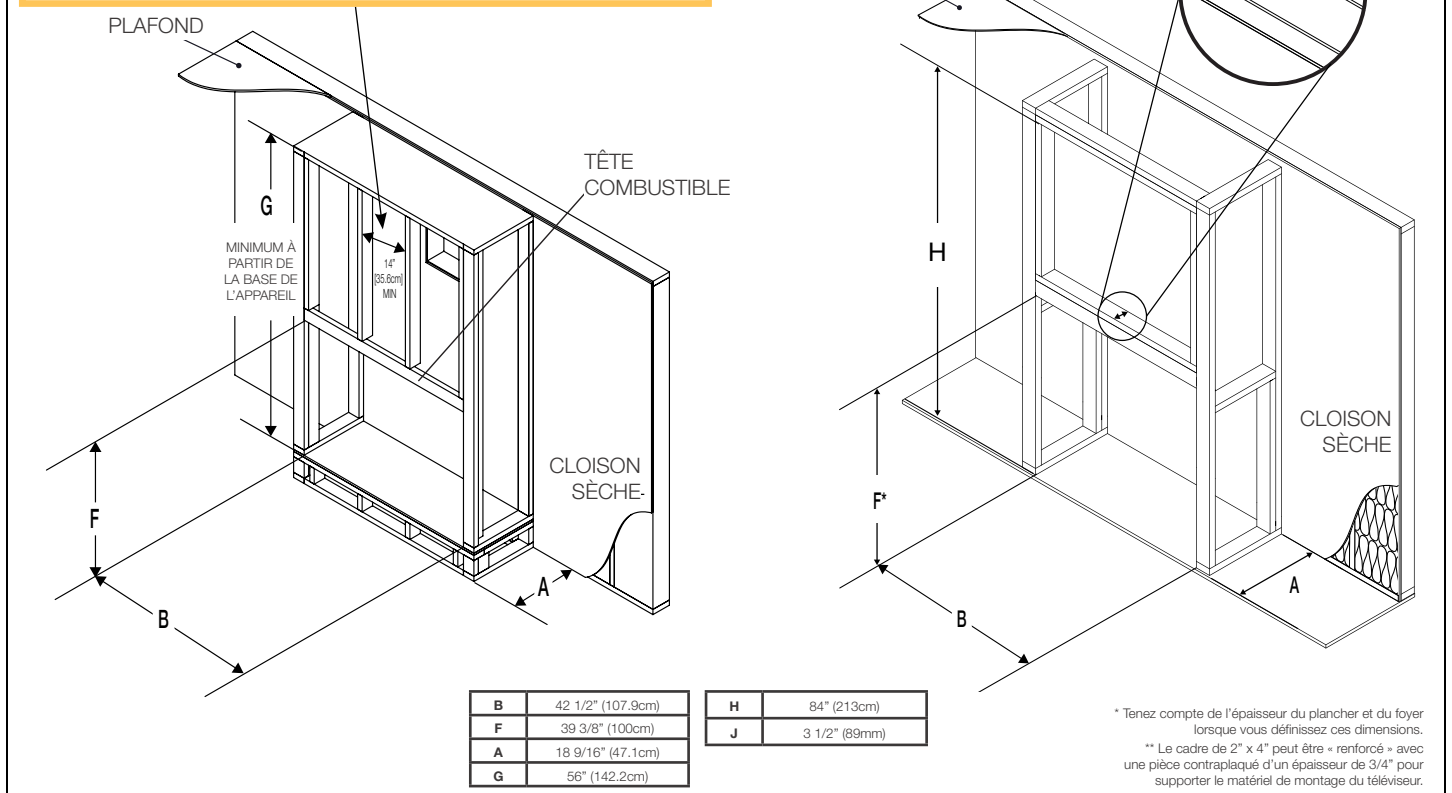

ASCENT™ LINEAR SERIES 46 DIRECT VENT GAS FIREPLACE



Specifications

Model	BTU	Width		Height		Depth		Viewing Area
		Actual	Framing	Actual	Framing	Actual	Framing	
BL46	24,000	46 7/8	47 3/8	39 1/16	39 3/8	18 5/16	18 9/16	14 1/8 x 39

Dimensions

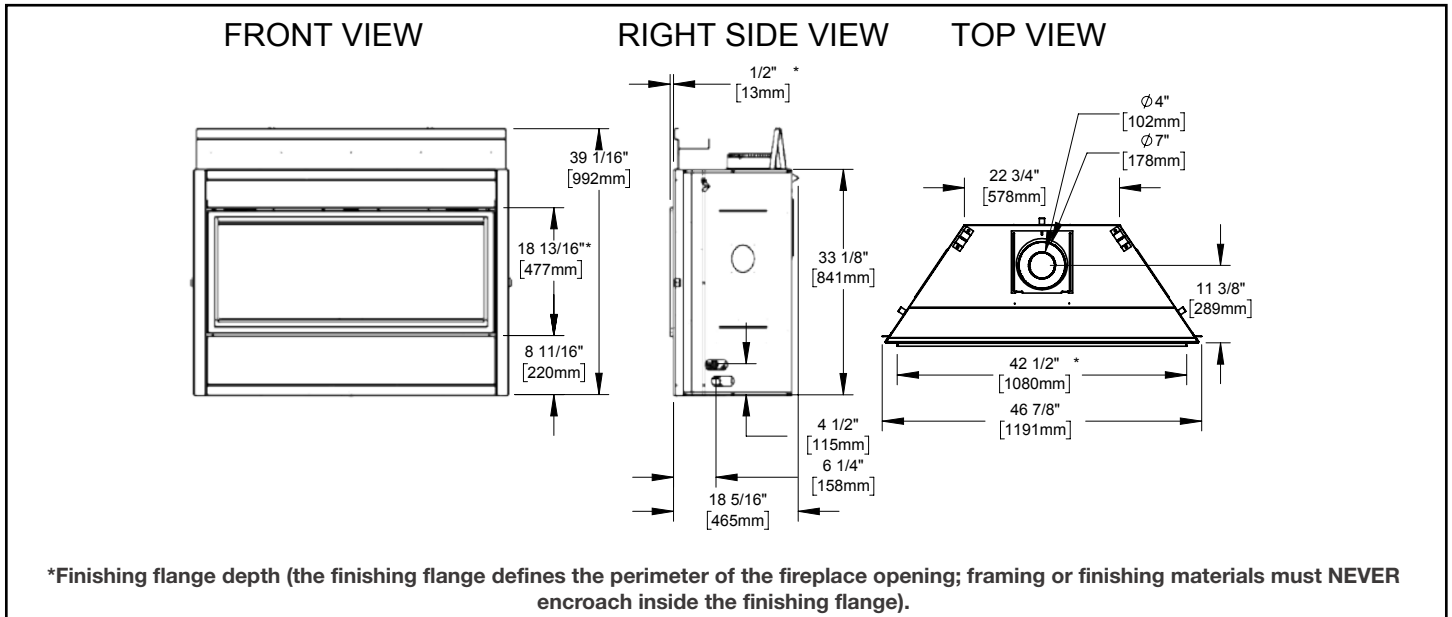

Appliance Location

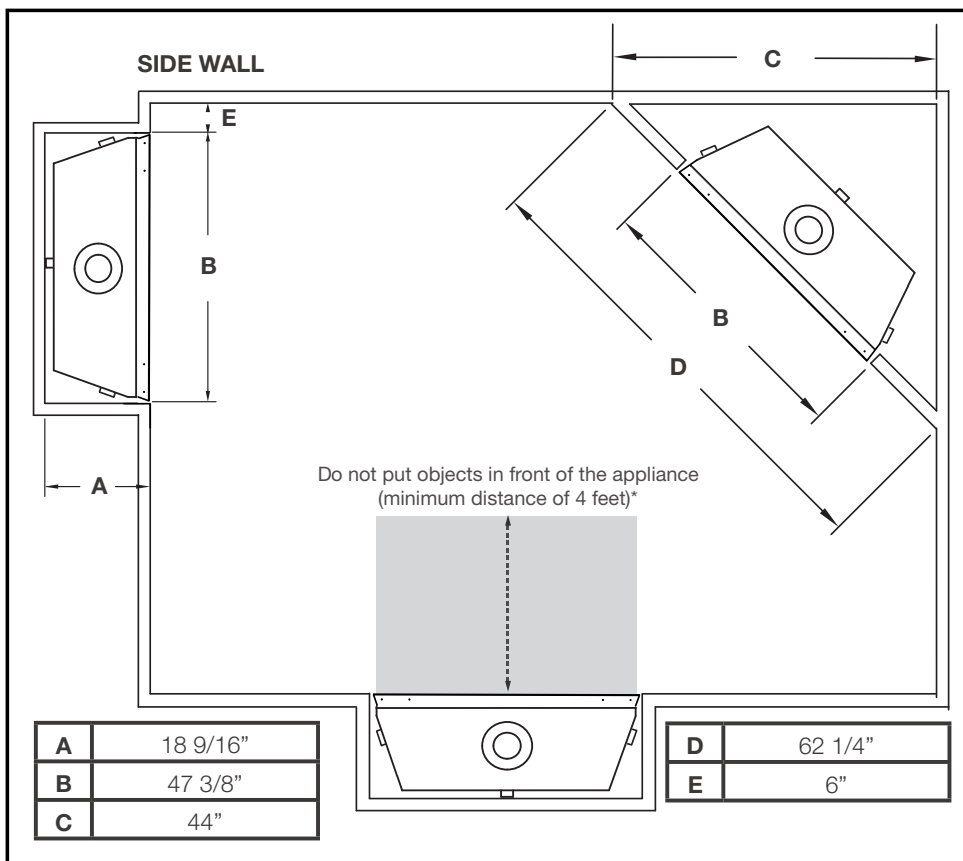

Combustible Mantel Clearances

Mantel Height (MH) vs. Mantel Depth (D)

Mantel Depth (D)	Mantel Height (MH)
1	12
2	13
3	14
4	15
5	16
6	17
7	18
8	19
9	20
10	21

Dimensions A, B, C, D, E are defined in the diagram above the graph.

DIMENSIONS DE LA TABLETTE		
Réf	Hauteur	Profondeur
A	27 1/2" (69.9cm)	N/A
B	12" (30.5cm)	2" (51mm)
C	14" (35.6cm)	4" (102mm)
D	16" (40.6cm)	6" (152mm)
E	18" (45.7cm)	8" (203mm)

Mantel clearances may be reduced ONLY if the Universal Heat Management System is installed (see Installation Manual).

ASCENT™ LINEAR SERIES 46 DIRECT VENT GAS FIREPLACE



Product information provided is not complete and is subject to change without notice. Please consult the installation manual for the most up to date installation information.

Wall Penetration

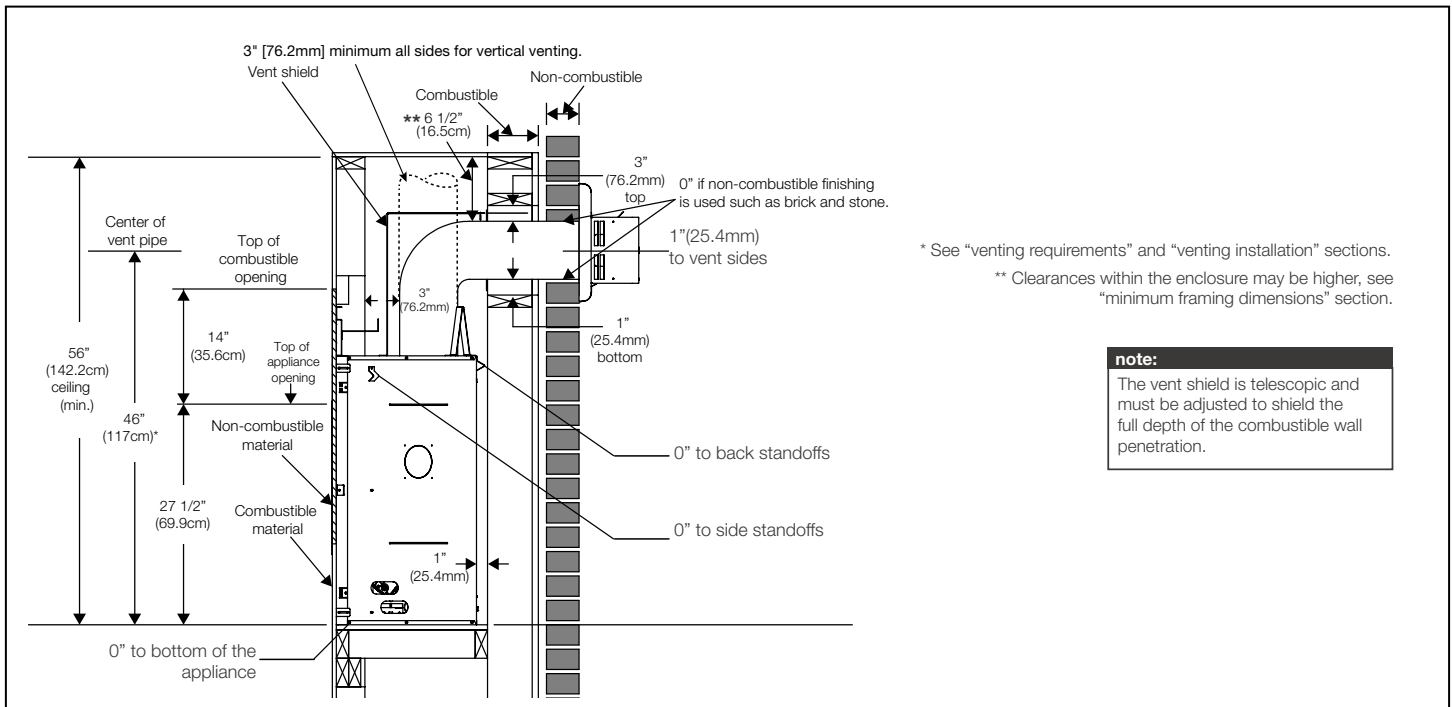

Framing

⚠ WARNING

- Do not build into this area - it must be left clear to provide adequate clearance for the vent in this 14" (35.6cm) wide area centered along the front of the appliance. The appliance should be in its final location before framing.

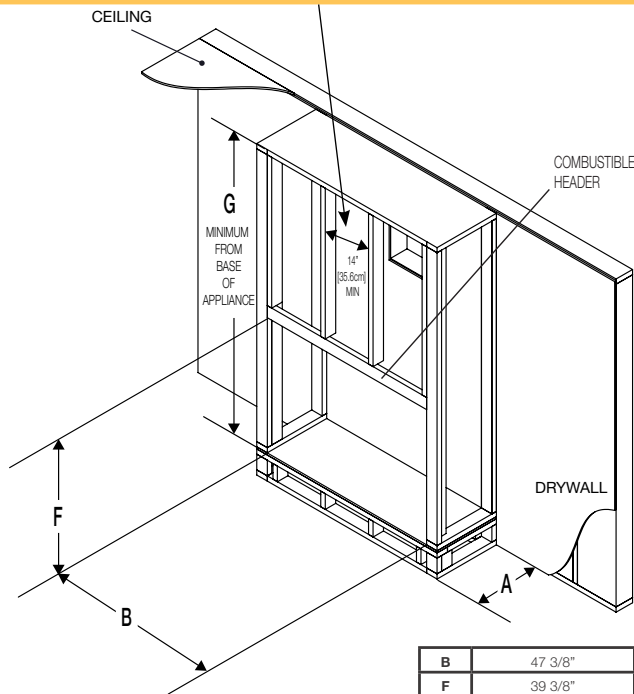

B	47 3/8"	H	84"
F	39 3/8"	I	3 1/2"
A	18 9/16"		
G	56"		

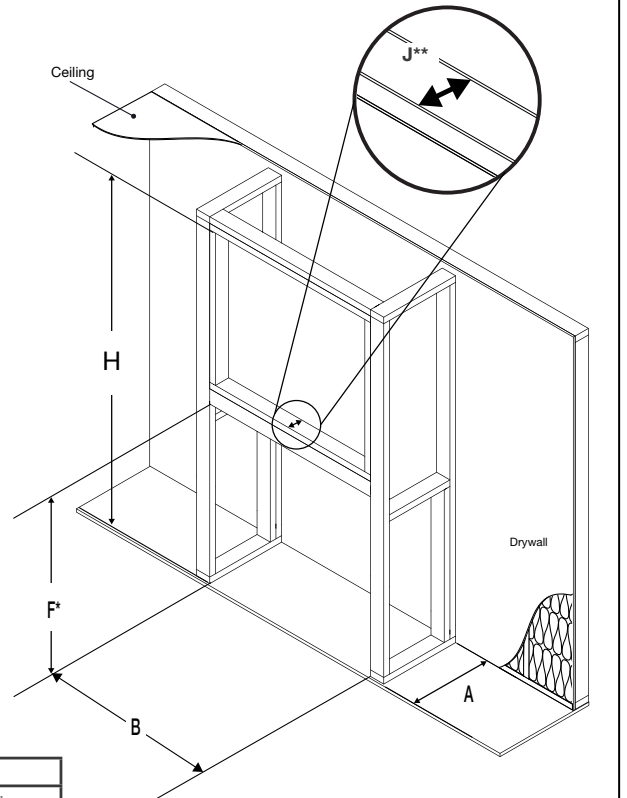

* Allow for finished floor and hearth thickness when setting these dimensions.
** 2" x 4" frame can be "backed" with 3/4" ply to support TV mounting hardware.

W415-3131 / 10.07.22

Spécifications

Modèle	BTU	Largeur		Hauteur		Profondeur		Dimensions de Vision
		Réel	Ossature	Réel	Ossature	Réel	Ossature	
BL46	24,000	46 7/8	47 3/8	39 1/16	39 3/8	18 5/16	18 9/16	14 1/8 x 39

Dimensions

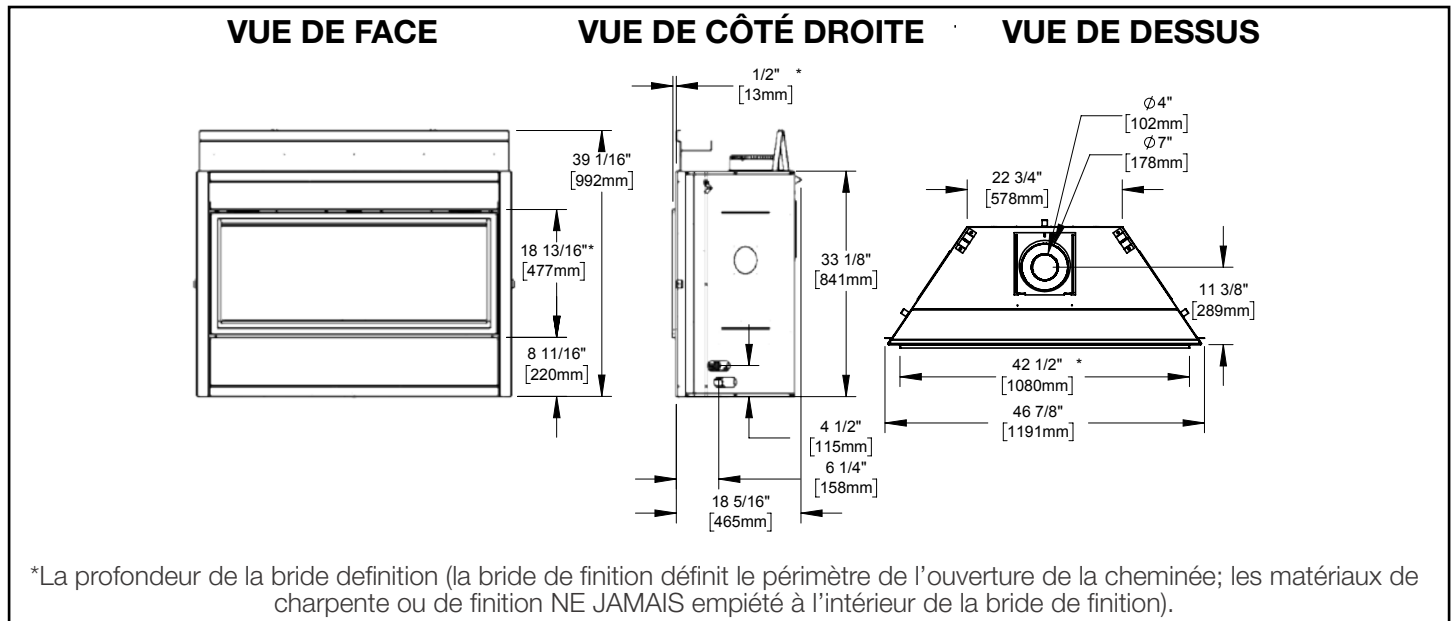

Emplacement de l'appareil

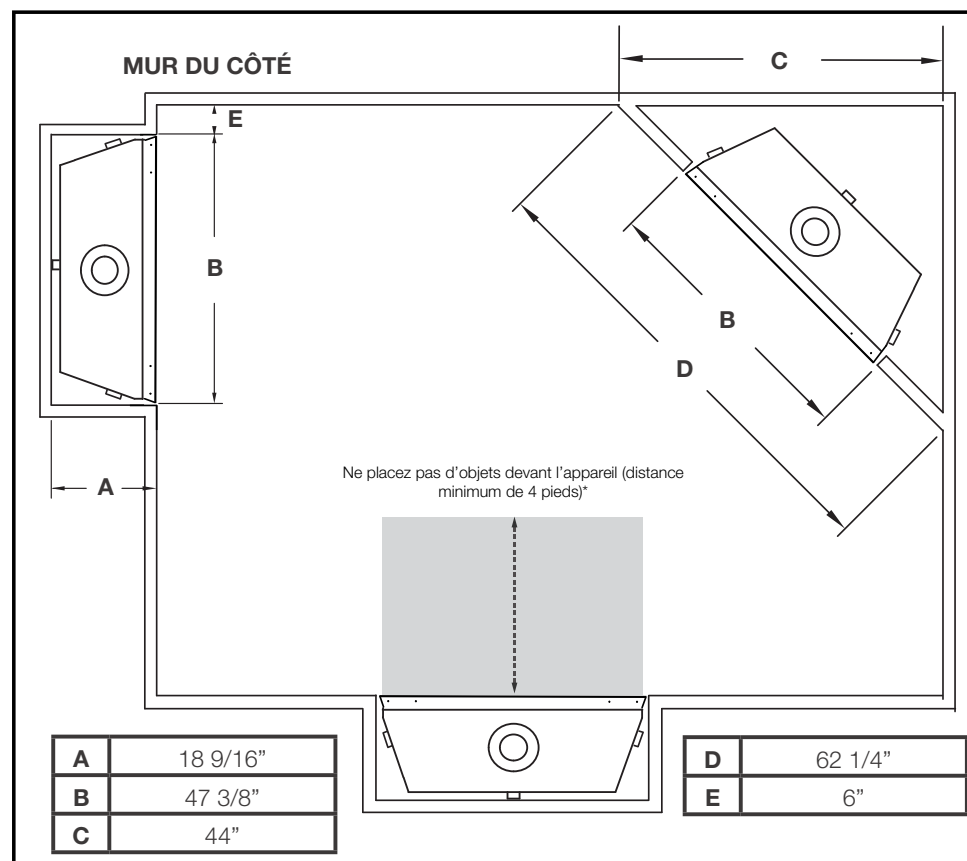

Dégagements Combustibles de la Tablette

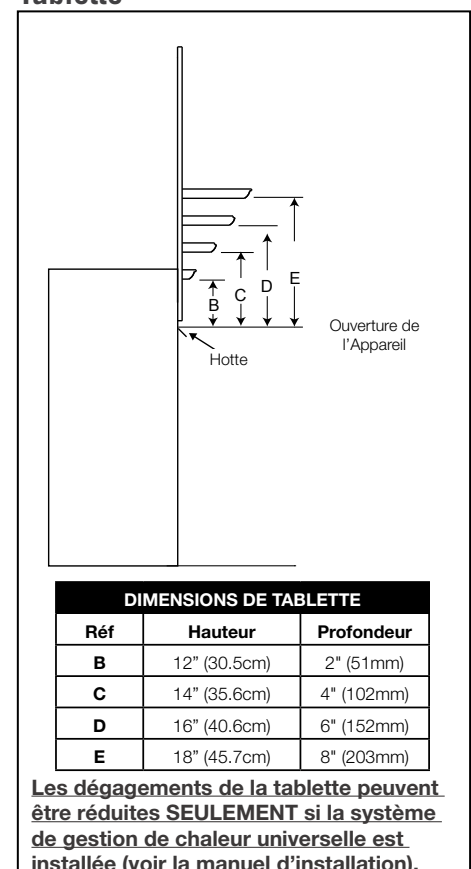

L'information du produit fourni n'est pas complet et est sujet de changer sans préavis. Consultez le manuel d'installation pour plus d'information d'installation actuel.

Pénétration du Mur

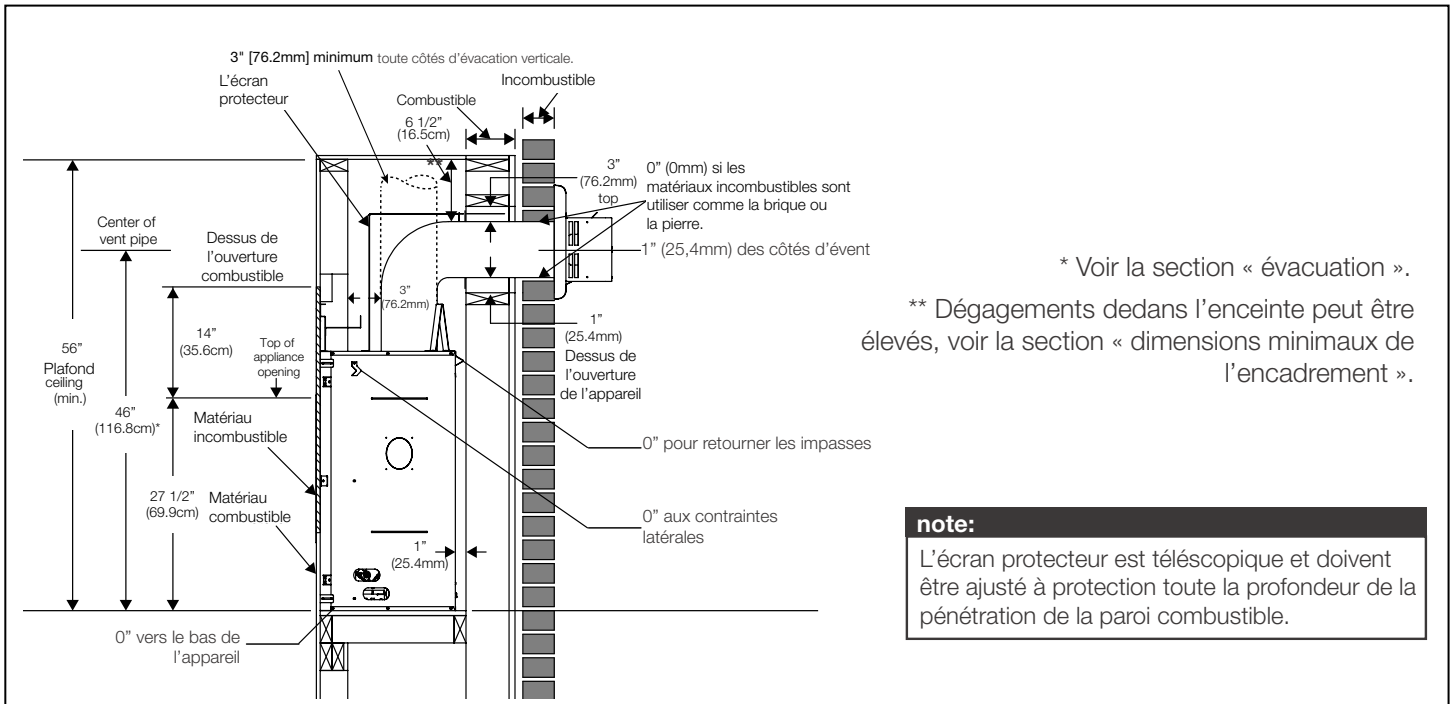

Ossature

⚠ AVERTISSEMENT

- Ne construisez pas dans cet espace de 14" (35,6cm) de largeur, centré le long de l'avant de l'appareil. Cet espace doit resté libre afin d'offrir un dégagement adéquat pour l'évacuation. Aucun matériaux combustible n'est permis.

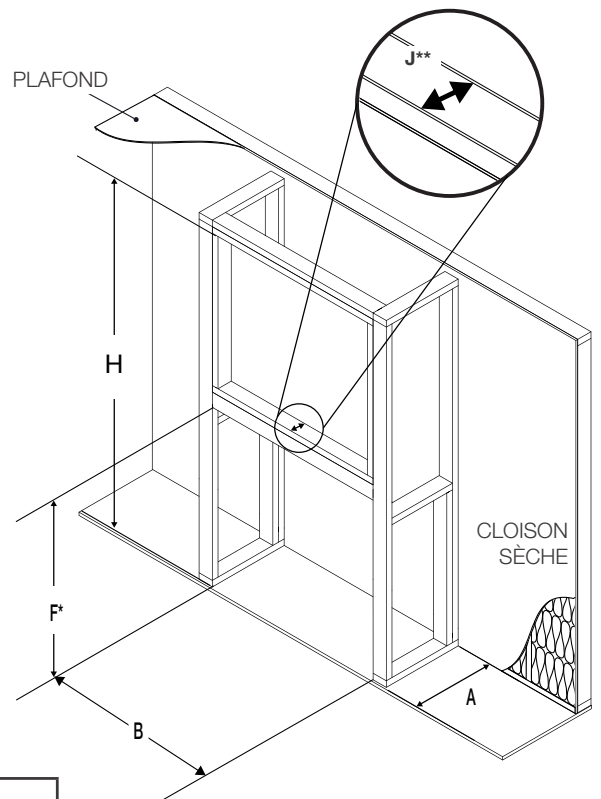
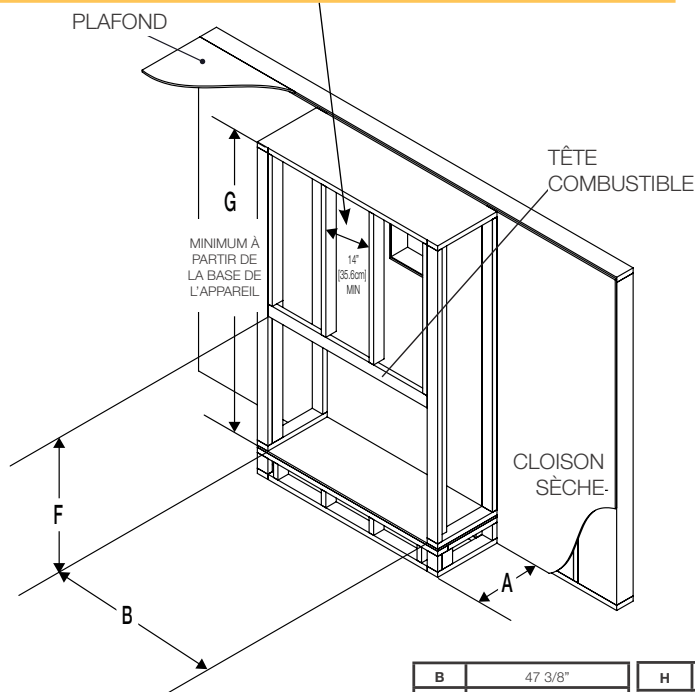

B	47 3/8"	H	84"
F	39 3/8"	I	3 1/2"
A	18 9/16"		
G	56"		

* Tenez compte de l'épaisseur du plancher et du foyer lorsque vous définissez ces dimensions.
 ** Le cadre de 2" x 4" peut être « renforcé » avec une pièce contraplâqué d'un épaisseur de 3/4" pour supporter le matériel de montage du téléviseur.

ASCENT™ LINEAR SERIES 56 DIRECT VENT GAS FIREPLACE



Specifications

Model	BTU	Width		Height		Depth		Glass
		Actual	Framing	Actual	Framing	Actual	Framing	
BL56	28 000 (NG) 26,500 (P)	56	56 1/2	38 13/16	39 3/8	18 5/16	18 9/16	14 1/4 x 49

Dimensions

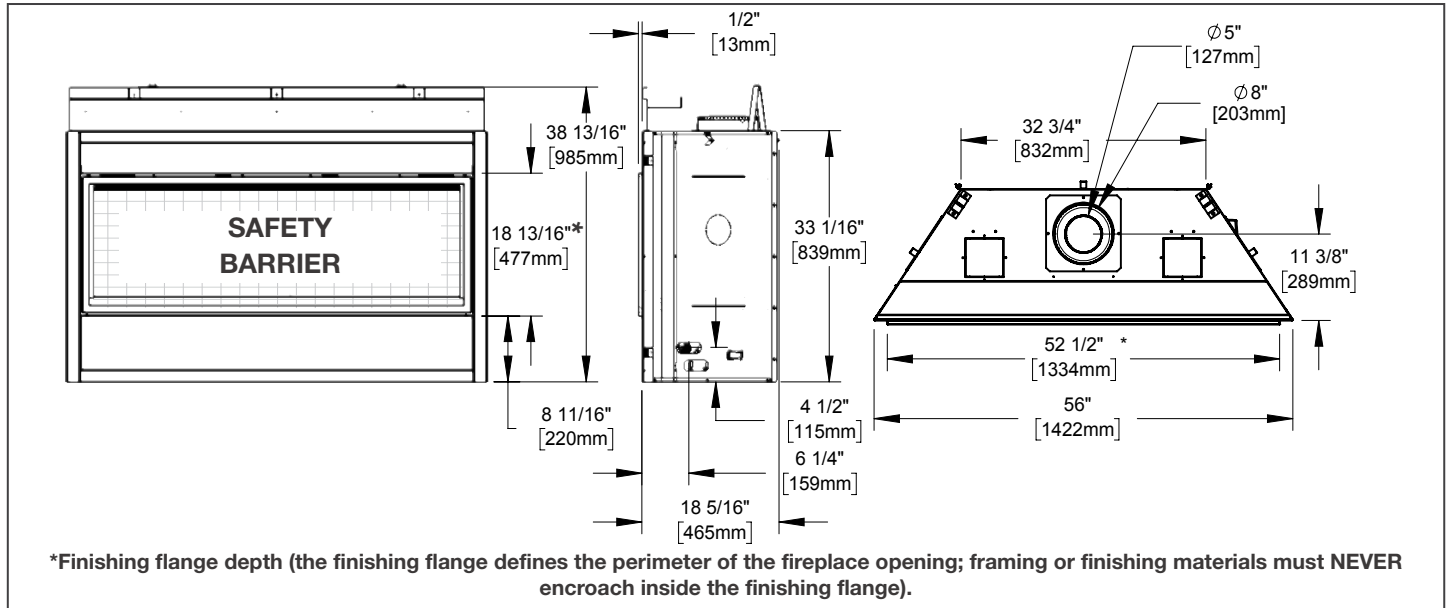

Appliance Location

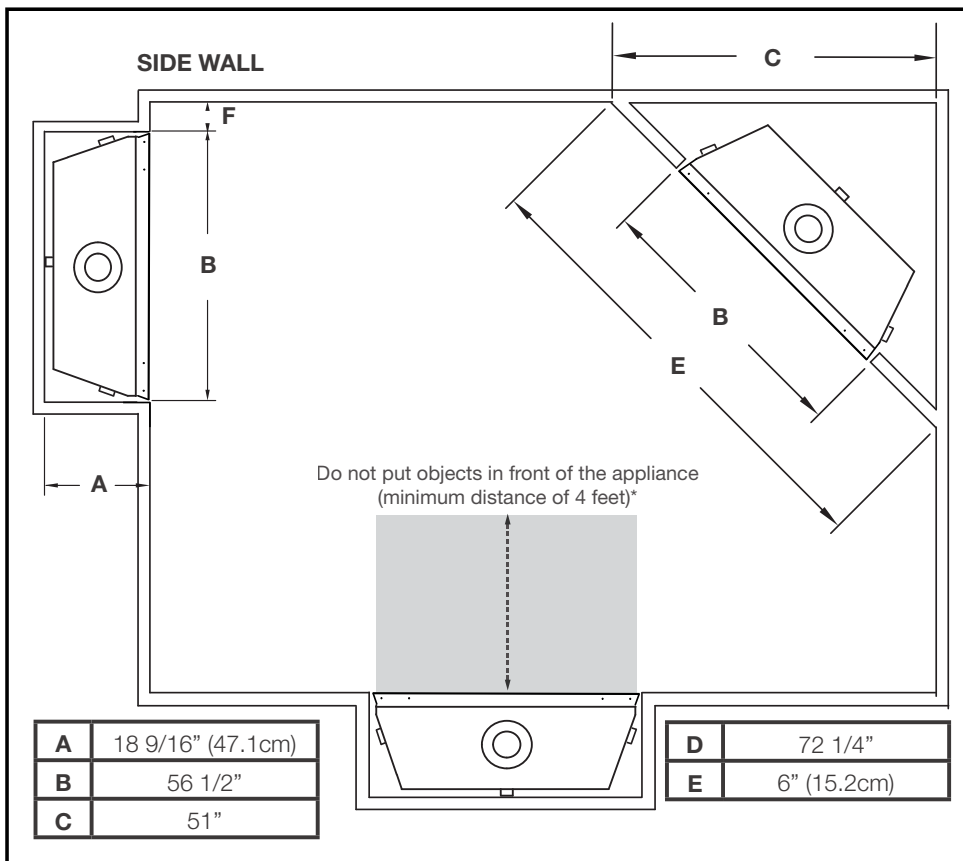

Combustible Mantel Clearances

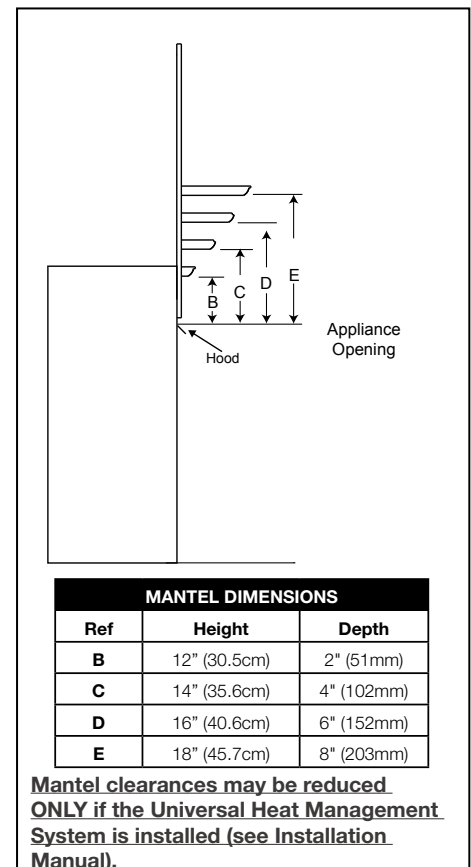

ASCENT™ LINEAR SERIES 56 DIRECT VENT GAS FIREPLACE



Product information provided is not complete and is subject to change without notice. Please consult the installation manual for the most up to date installation information.

Wall Penetration

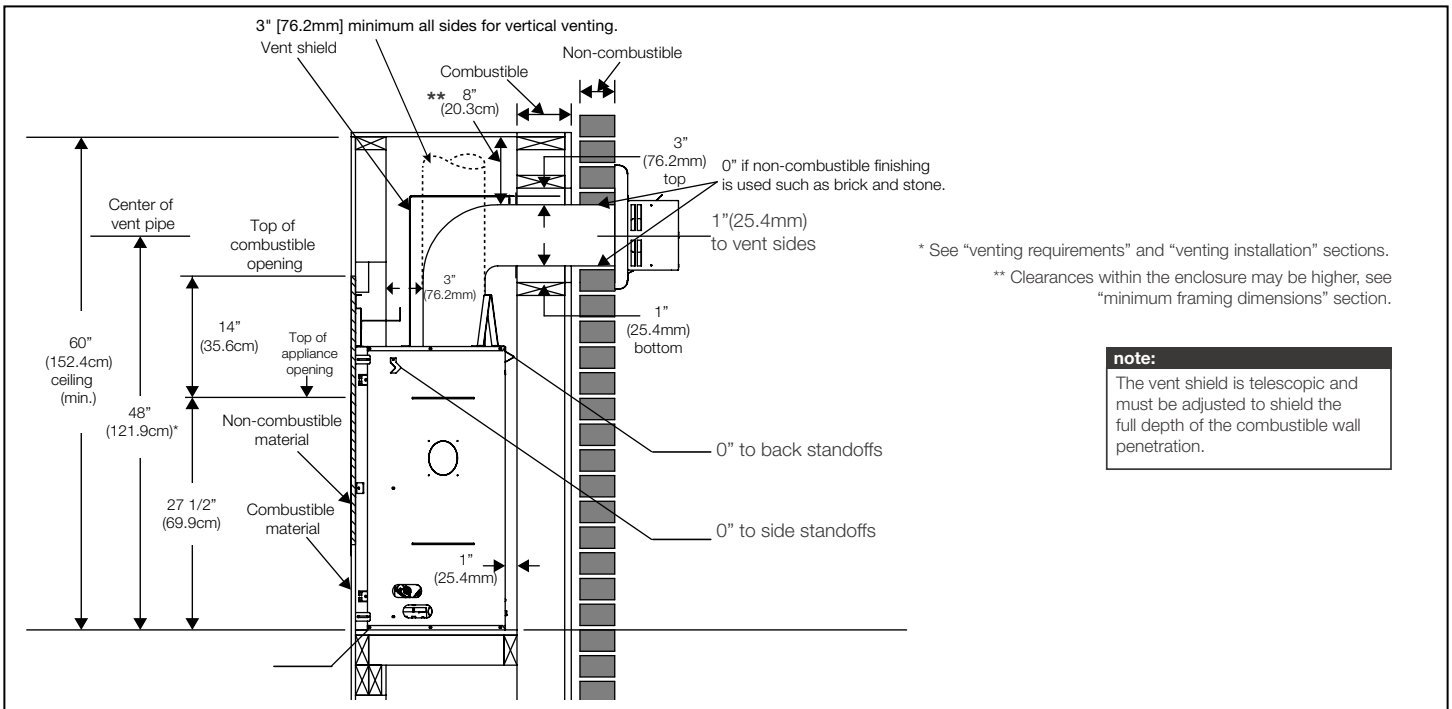

Framing

⚠ WARNING

- Do not build into this area - it must be left clear to provide adequate clearance for the vent in this 14" (35.6cm) wide area centered along the front of the appliance. The appliance should be in its final location before framing.

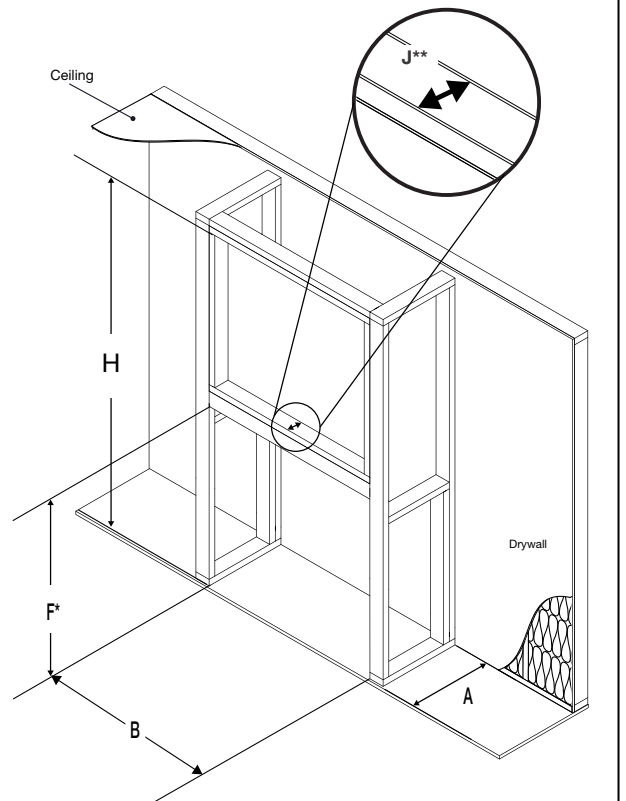
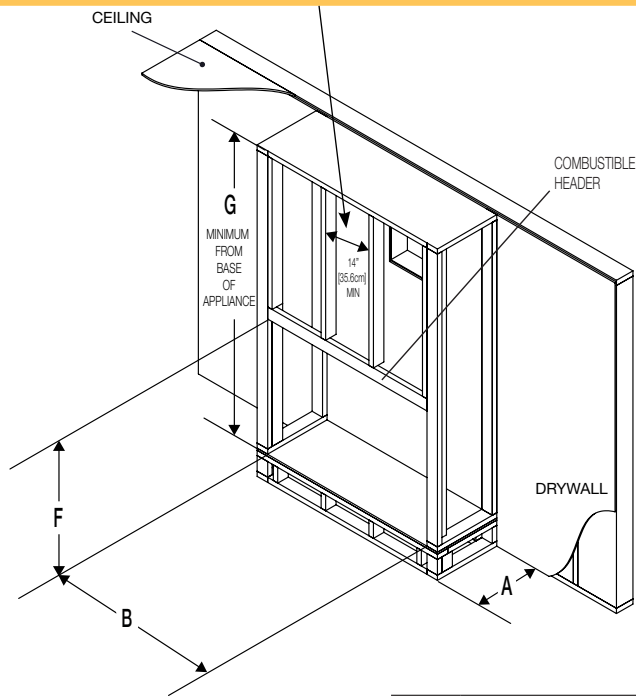

B	56 1/2"
F	39 3/8" (100cm)
A	18 9/16" (47.1cm)
G	60"

H	84" (213cm)
J	3 1/2" (89mm)

* Allow for finished floor and hearth thickness when setting these dimensions.

** 2" x 4" frame can be "backed" with 3/4" ply to support TV mounting hardware.

W415-3066 / A / 10.07.22

Spécifications

Modèle	BTU	Largeur		Hauteur		Profondeur		Verre
		Réel	Ossature	Réel	Ossature	Réel	Ossature	
BL56	28 000 (GN) 26 500 (P)	56	56 1/2	38 13/16	39 3/8	18 5/16	18 9/16	14 1/4 x 49

Dimensions

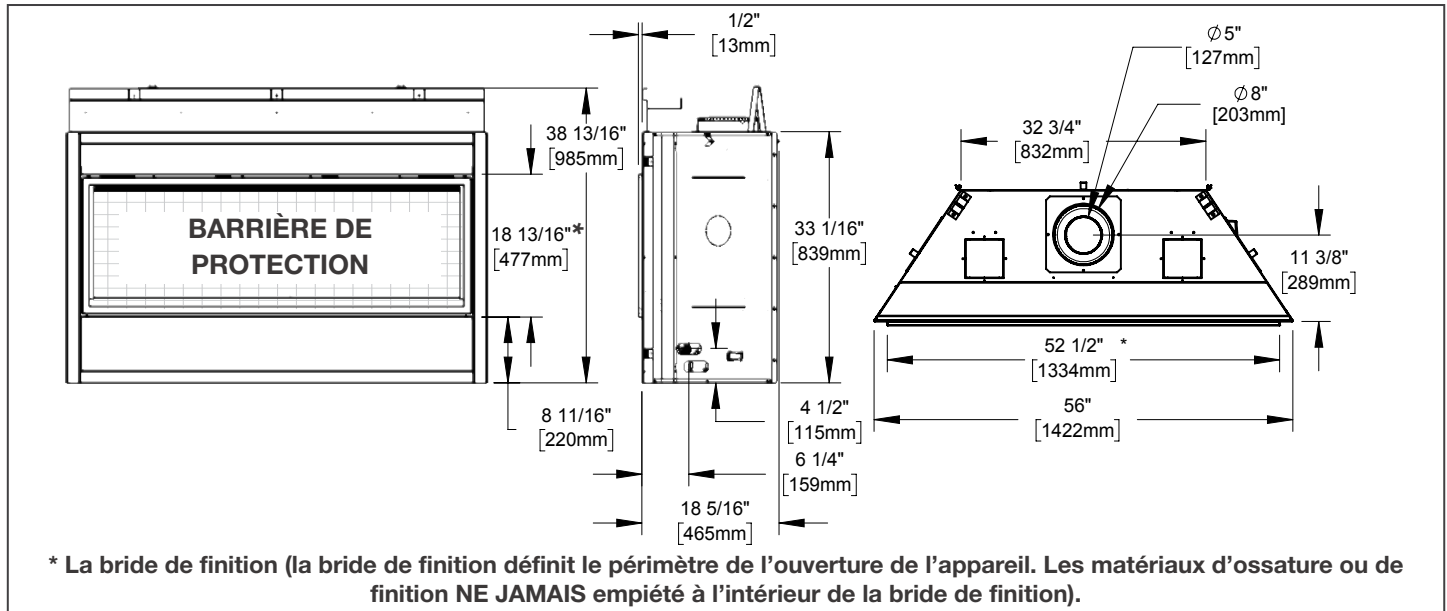

Emplacement de l'appareil

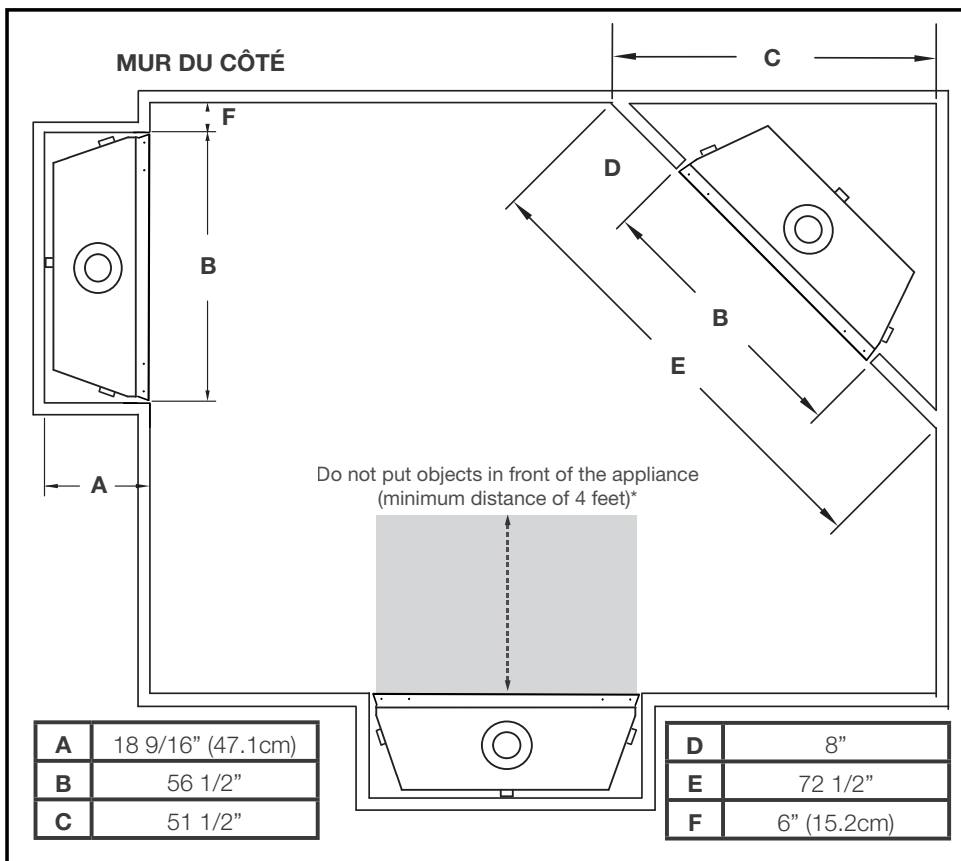

Dégagements Combustibles de la Tablette

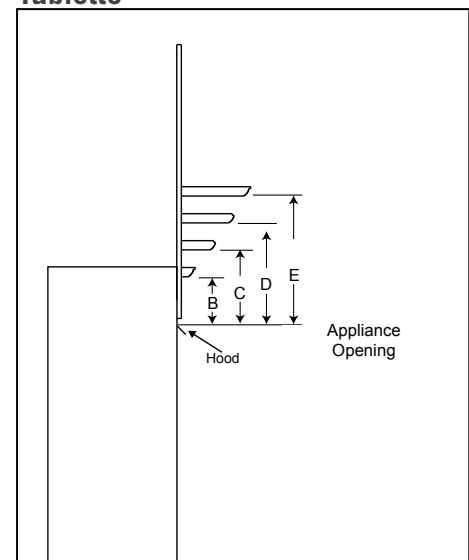

DIMENSIONS DE TABLETTE		
Réf	Hauteur	Profondeur
B	12" (30.5cm)	2" (51mm)
C	14" (35.6cm)	4" (102mm)
D	16" (40.6cm)	6" (152mm)
E	18" (45.7cm)	8" (203mm)

Les dégagements de la tablette peuvent être réduites SEULEMENT si la système de gestion de chaleur universelle est installée (voir la manuel d'installation).

FOYER À GAZ VENTILÉ DIRECTE SÉRIES ASCENT^{MD} LINÉAIRE 56



L'information du produit fourni n'est pas complet et est sujet de changer sans préavis. Consultez le manuel d'installation pour plus d'information d'installation actuel.

Pénétration du Mur

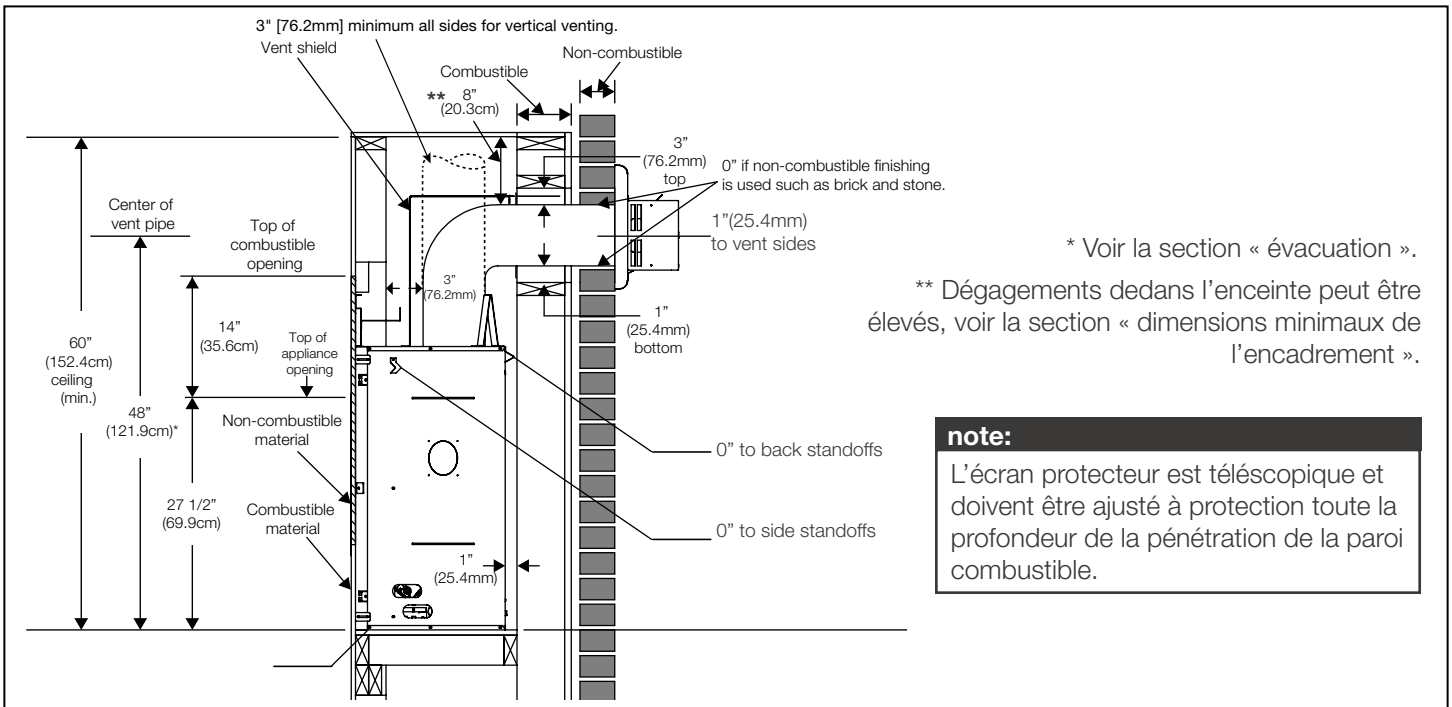

note:
L'écran protecteur est télescopique et doivent être ajusté à protection toute la profondeur de la pénétration de la paroi combustible.

Ossature

⚠ AVERTISSEMENT

- Ne construisez pas dans cet espace de 14" (35,6cm) de largeur, centré le long de l'avant de l'appareil. Cet espace doit resté libre afin d'offrir un dégagement adéquat pour l'évacuation. Aucun matériaux combustible n'est permis.

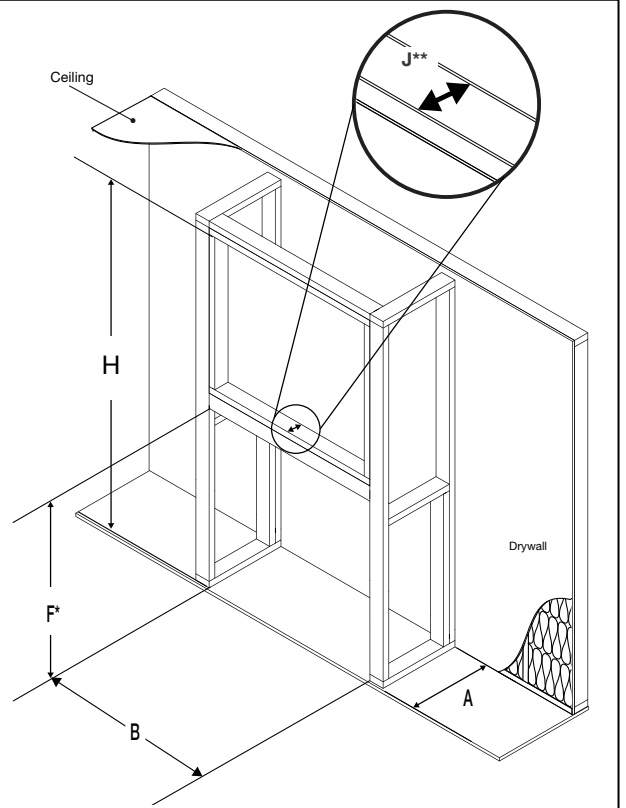
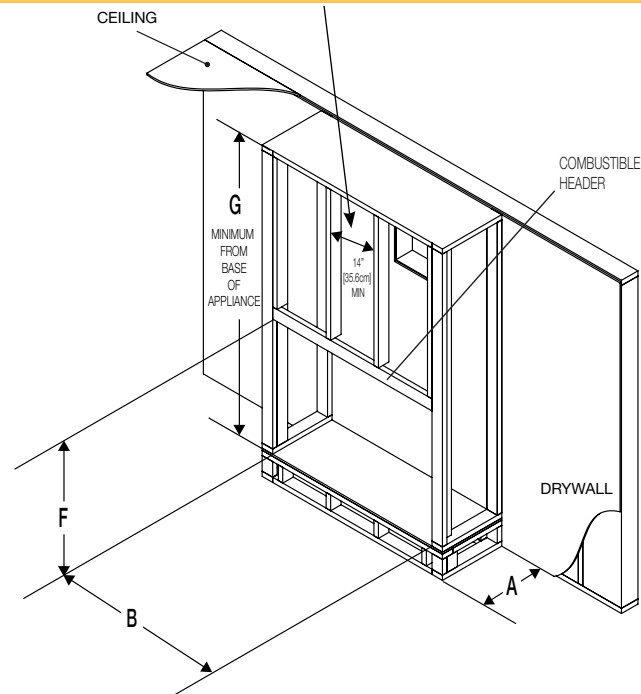

B	56 1/2"
F	39 3/8" (100cm)
A	18 9/16" (47.1cm)
G	60"

H	84" (213cm)
J	3 1/2" (89mm)

* Tenez compte de l'épaisseur du plancher et du foyer lorsque vous définissez ces dimensions.
** Le cadre de 2" x 4" peut être renforcé avec une pièce contraplâqué d'un épaisseur de 3/4" pour supporter le matériel de montage du téléviseur.