





Assembly Manual for MAUI

Congratulations on your new Petit Puk bed! Get ready to transform your kid's sleeping space into a fortress of imagination, a castle of coziness, and a launchpad for their sweetest dreams! When you follow this step-by-step assembly, you'll breeze through the process.

Quick Checklist:

-  Is everything complete?
-  All pieces in good shape?
-  Do no start adding glue before you made sure all pieces are there and in perfect shape
-  Note! Applying glue to the bed base is **not** mandatory, as it could hinder the disassembly process later on. Let's keep things flexible for future adventures!
-  Ready to take a photo of your great work once completed and share with us?

Ticked all the boxes? Put on your superhero cape, and let's dive into the wonderful world of bed building.

Big wave,
Team Petit Puk

Questions? Reach out via customercare@petitpuk.com

Compliments? Tag us on instagram @petitpuk

P.3

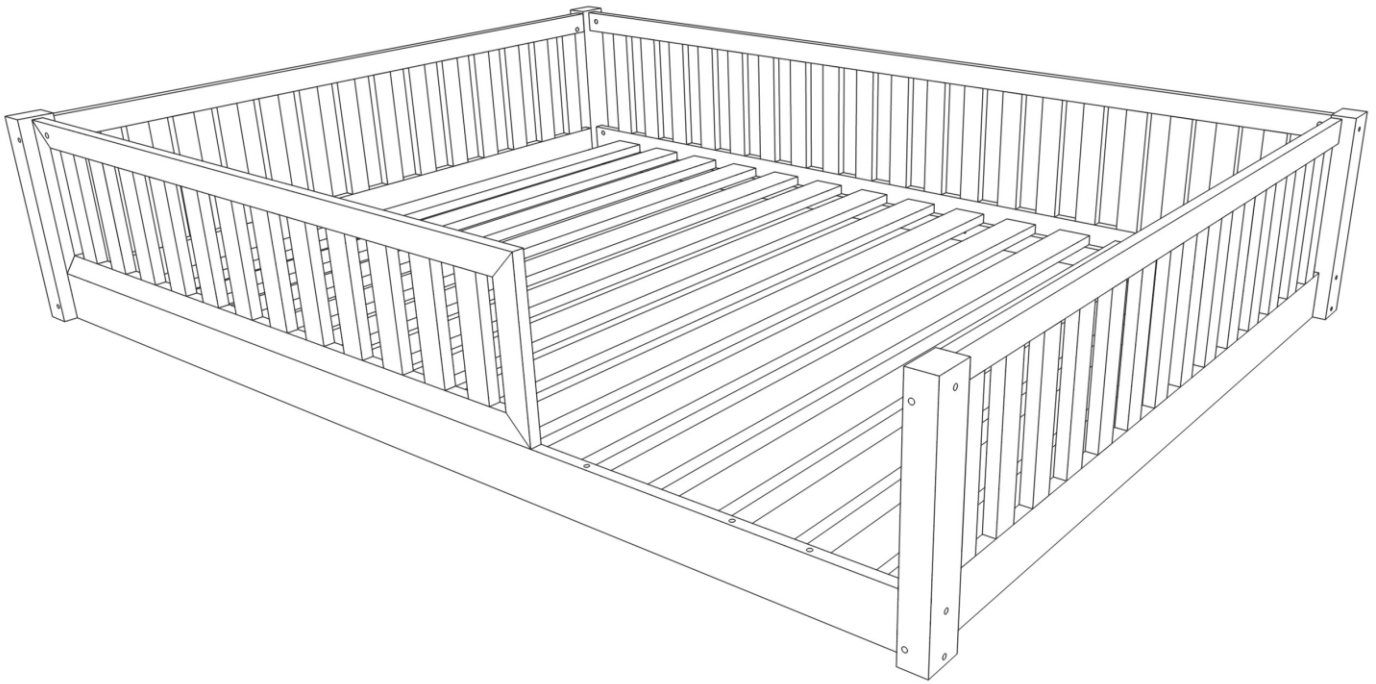

P.12

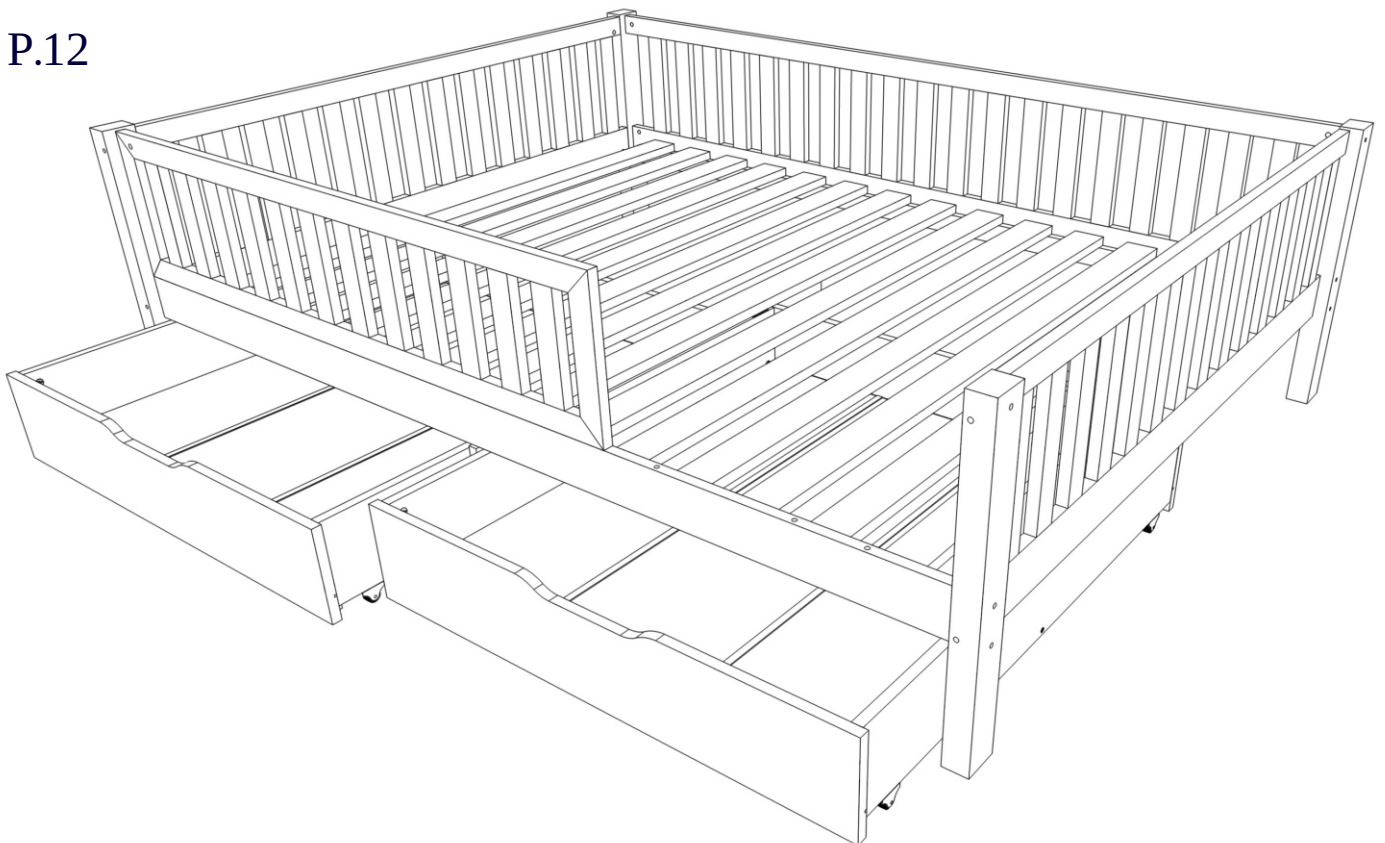



IMPORTANT! KEEP FOR FUTURE REFERENCE: READ CAREFULLY.

- a. Warning: Be aware of the risks posed by open fire and other heat sources such as electric or gas heaters etc. near the bed.
- b. Warning: Do not use the bed if any part is damaged, torn or missing, use only the parts approved by the manufacturer.
- c. Warning: Do not leave anything in the bed or place the bed near any other equipment that could support the foot or pose a risk of suffocation or hanging the child, such as cords, curtain / blind cords.
- d. Warning: Do not use more than one mattress in the bed.
- e. Recommended maximum mattress thickness of 12 cm - 15 cm.
- f. The selected bed size is the size of the mattress to be used.
- g. It is recommended that all assembly elements be tightened well during assembly, regularly checked and tightened if necessary.

Warning: Before starting the assembly, please check all the elements. If any parts are damaged, please do not assemble the bed, and notify us of the damaged parts immediately by email, with photos, so that we can send you replacement parts. Once the bed has been assembled, any complaint regarding damages parts will no longer be accepted.

**WICHTIG! FÜR SPÄTERES NACHSCHLAGEN AUFBEWAHREN:
SORGFÄLTIG LESEN.**

- a. **Warnung:** Seien Sie sich der Risiken bewusst, die durch offenes Feuer und andere Wärmequellen wie Elektro- oder Gasheizungen usw. in der Nähe des Bettes entstehen.
- b. **Warnung:** Verwenden Sie das Bett nicht, wenn Teile beschädigt, gerissen oder fehlen, verwenden Sie nur die vom Hersteller zugelassenen Teile.
- c. **Warnung:** Lassen Sie nichts im Bett liegen und stellen Sie das Bett nicht in die Nähe anderer Geräte, die den Fuß stützen oder eine Erstickungsgefahr oder das Aufhängen des Kindes darstellen könnten, wie z.B. Drähte, Gardinen-/Rolloschnüre.
- d. **Warnung:** Verwenden Sie nicht mehr als eine Matratze im Bett.
- e. **Empfohlene maximale Matratzendicke** von 12 cm - 15 cm.
- f. Die gewählte Bettgröße ist die Größe der zu verwendenden Matratze.
- g. Es wird empfohlen, alle Montageelemente während der Montage gut anzuziehen, regelmäßig zu kontrollieren und ggf. nachzuziehen.

Achtung: Bitte prüfen Sie vor dem Aufbau ob Sie alle Elemente erhalten haben. Sollten einige Teile beschädigt sein, bitten wir Sie das Bett vorerst nicht aufzubauen und uns die Schäden schriftlich zu melden. Wir werden diese schnellstens ersetzen. Sollte das Bett bereits aufgebaut worden sein, so kann die Reklamation nicht akzeptiert werden.

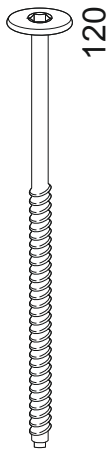

3x

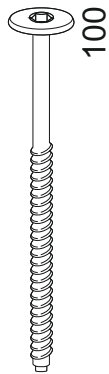

9x

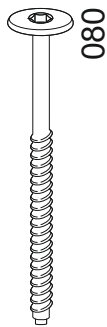

10x

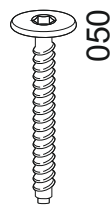

2x



20x



1x

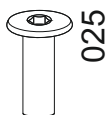

3x

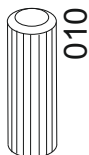

8x



16x



16x



1x

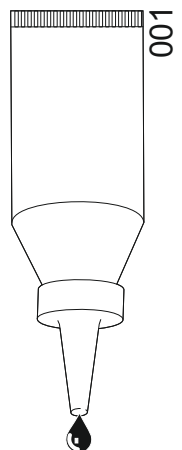

1x

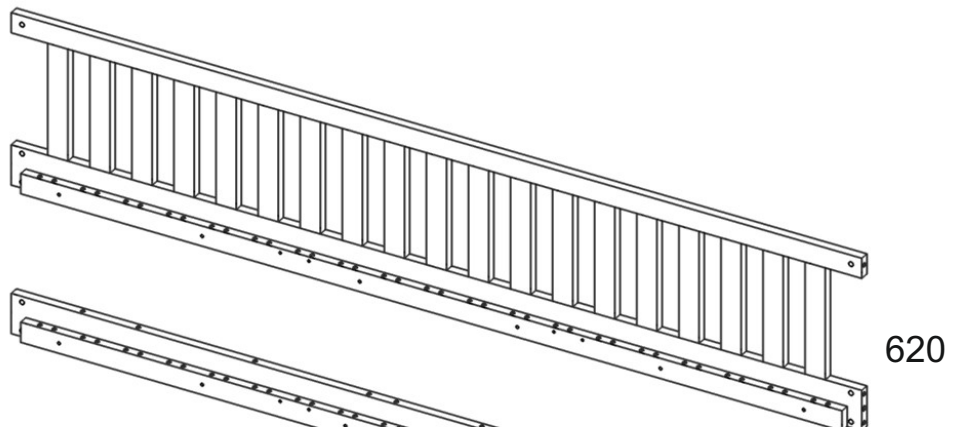

620

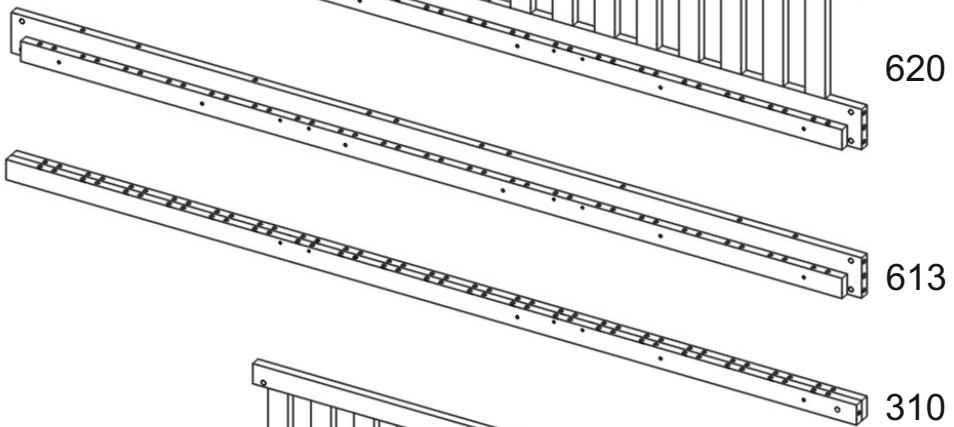

613

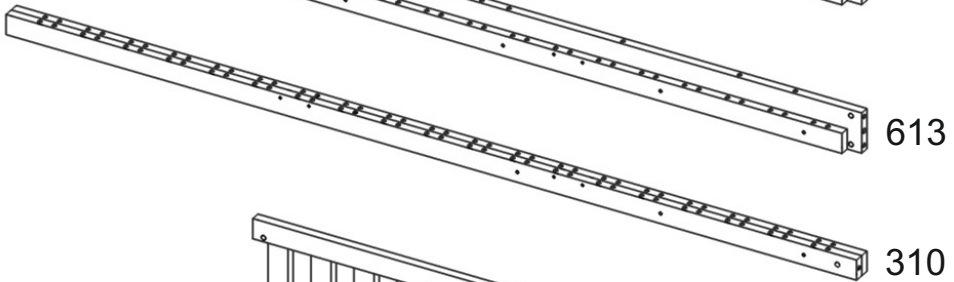

310

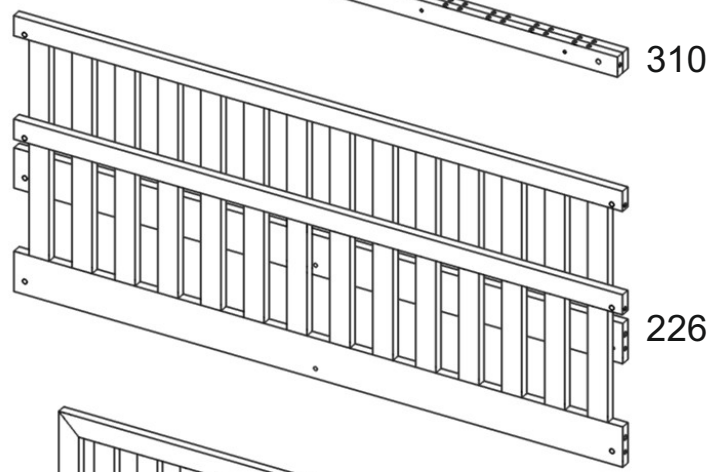

226

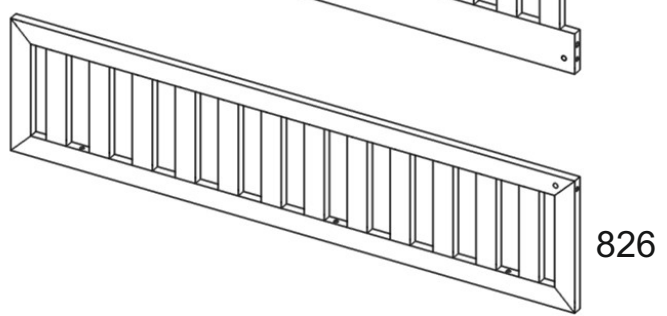

826

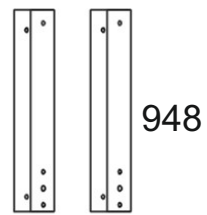

948

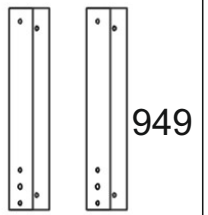

949

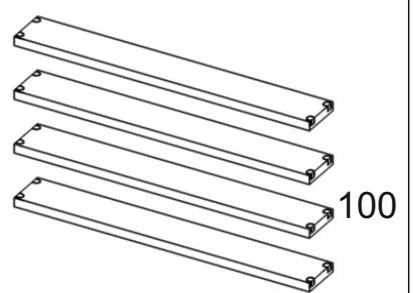

100

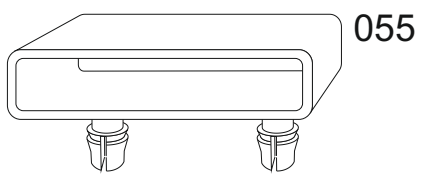

055

76x

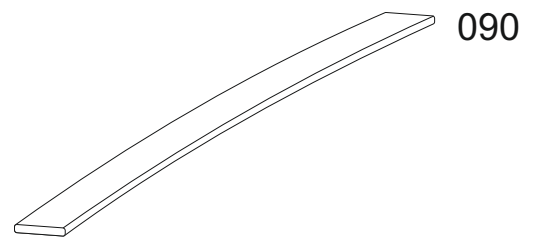

090

38x

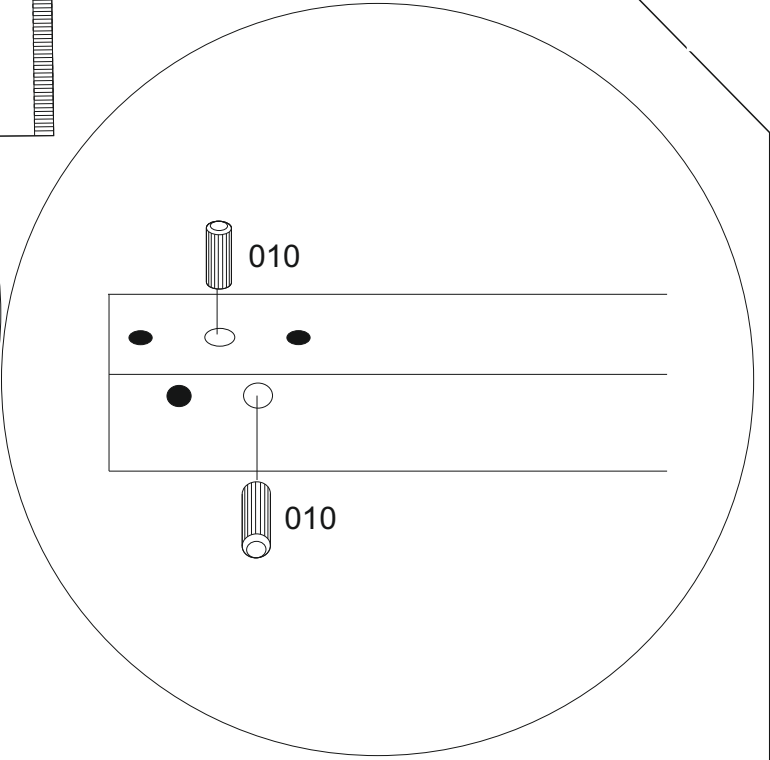
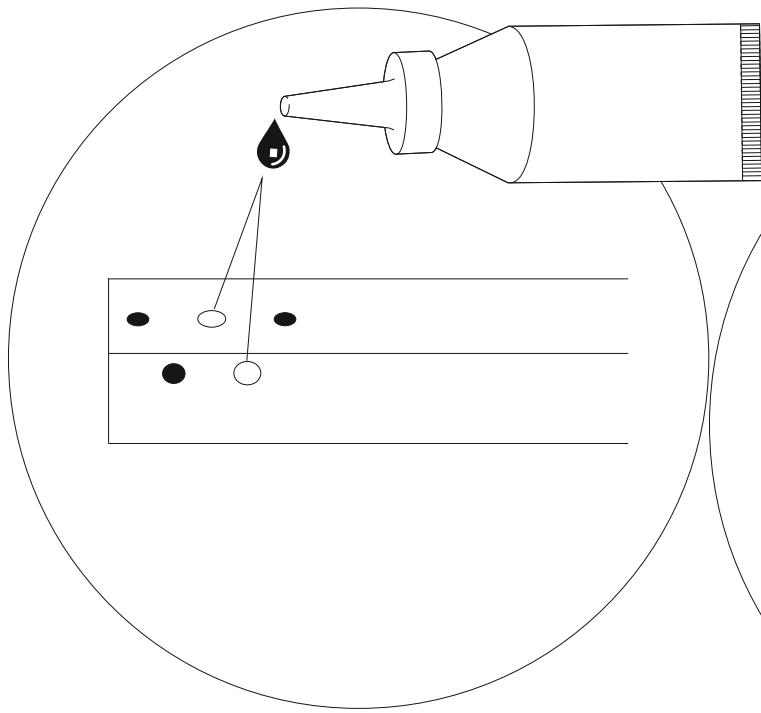

948

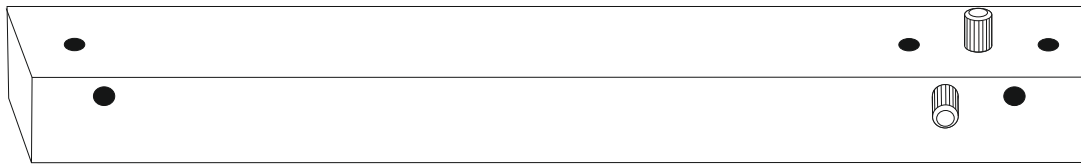

949

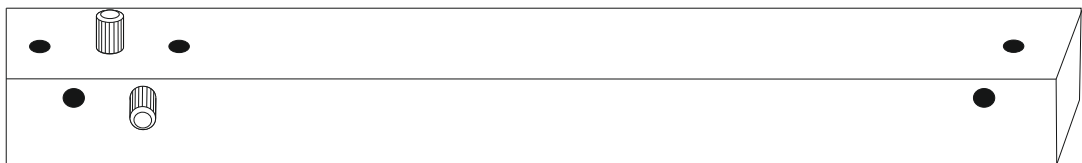
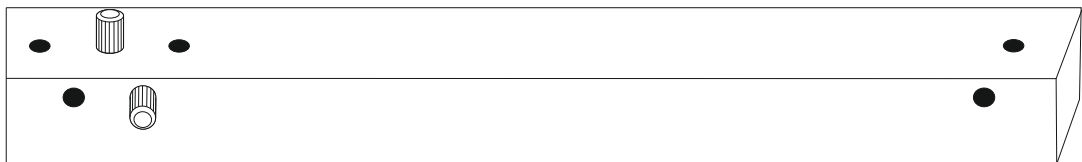

230

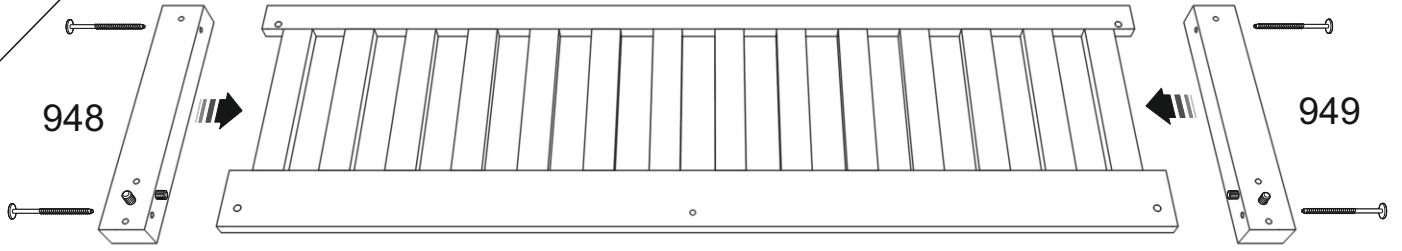

230

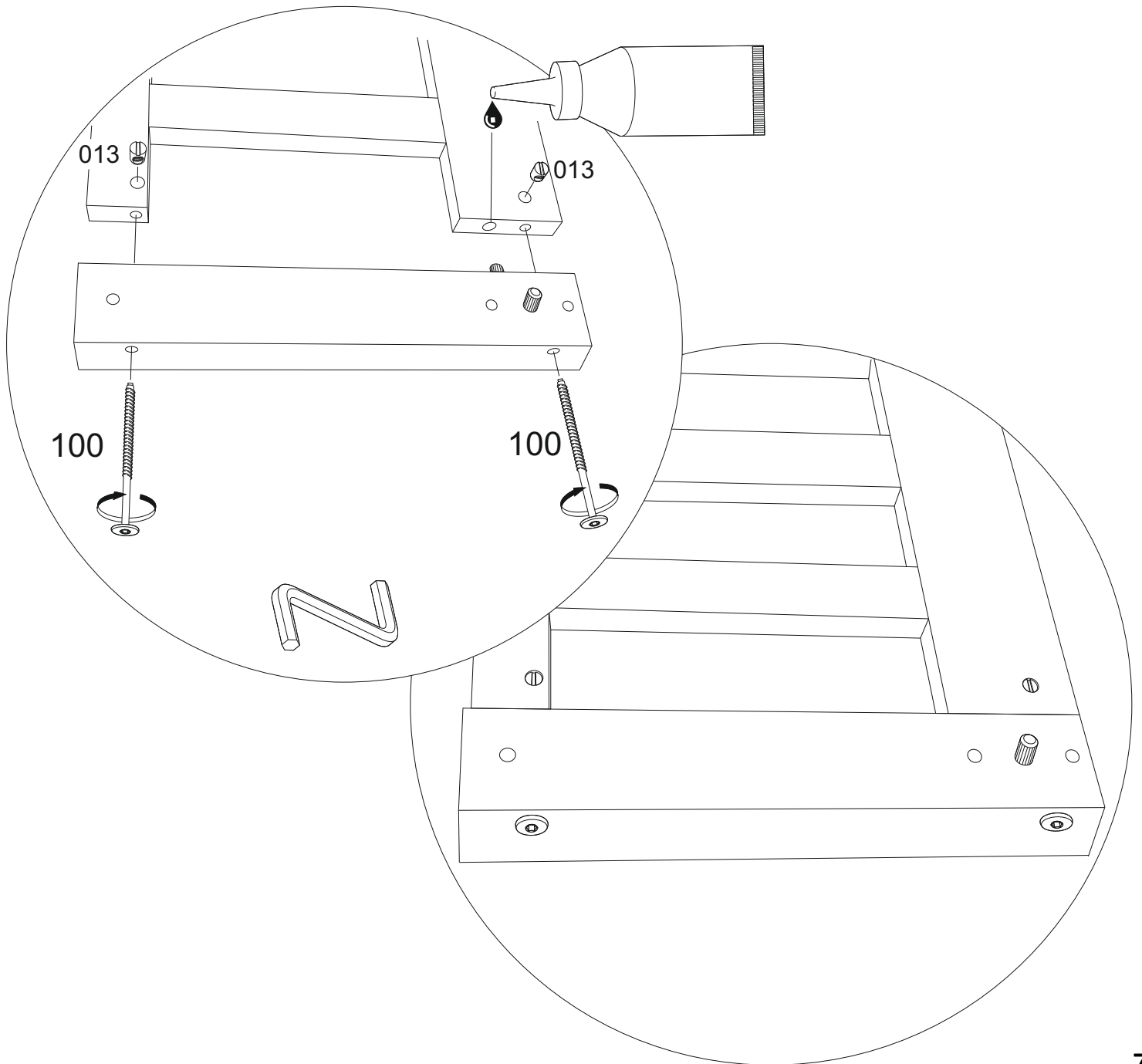
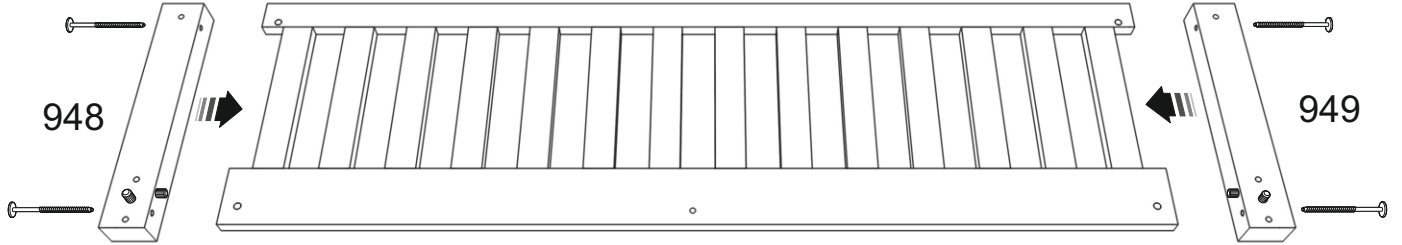

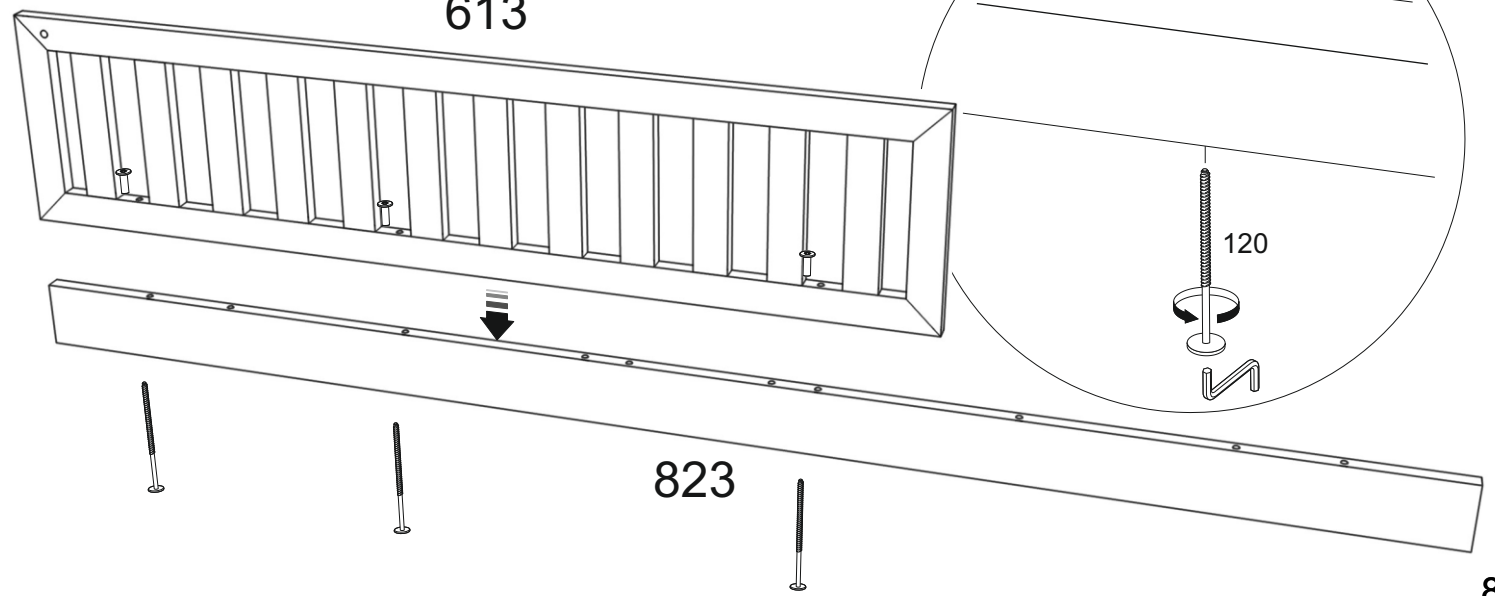
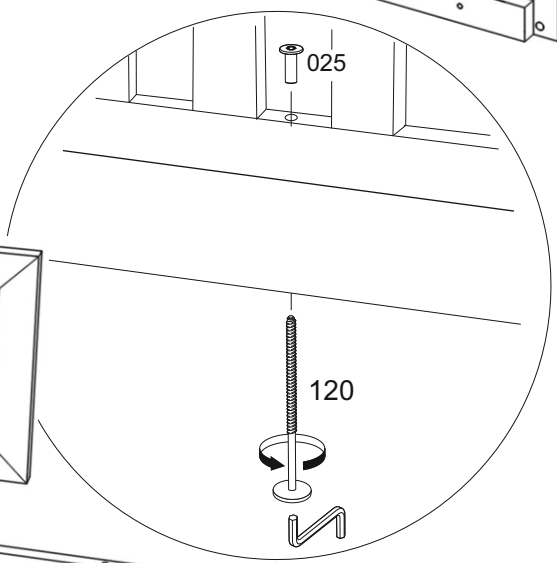
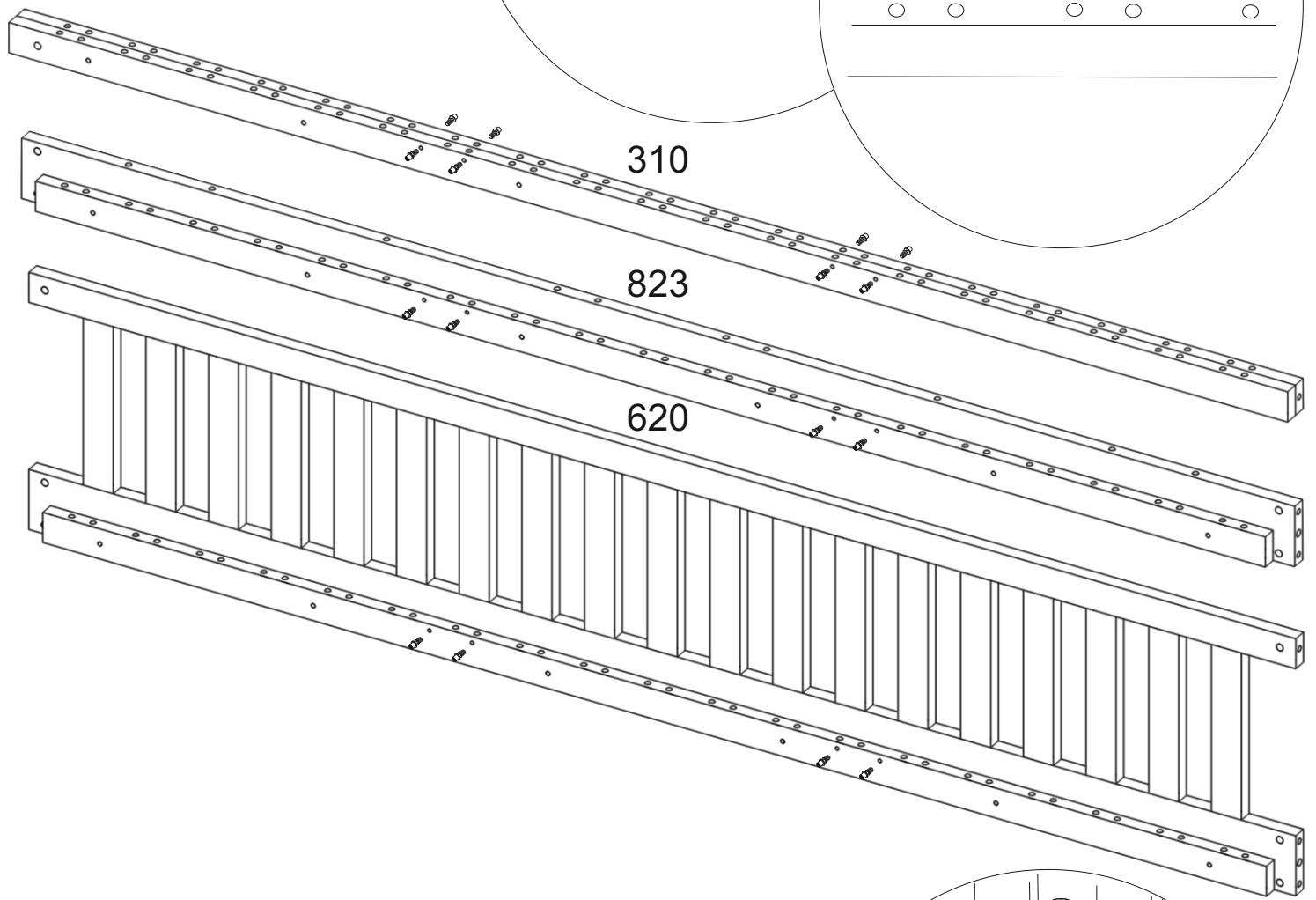
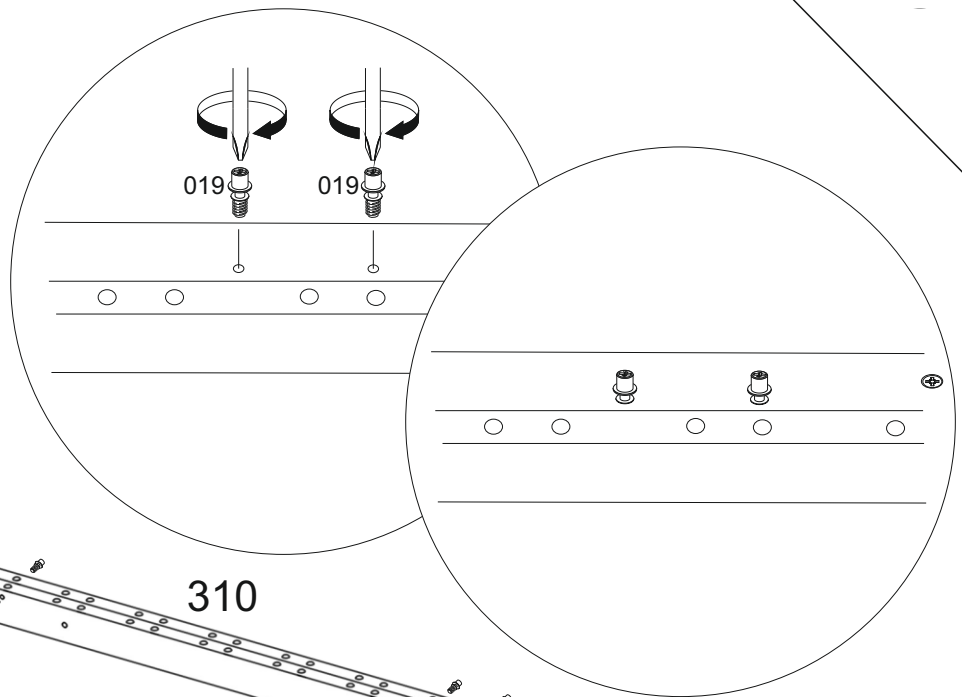

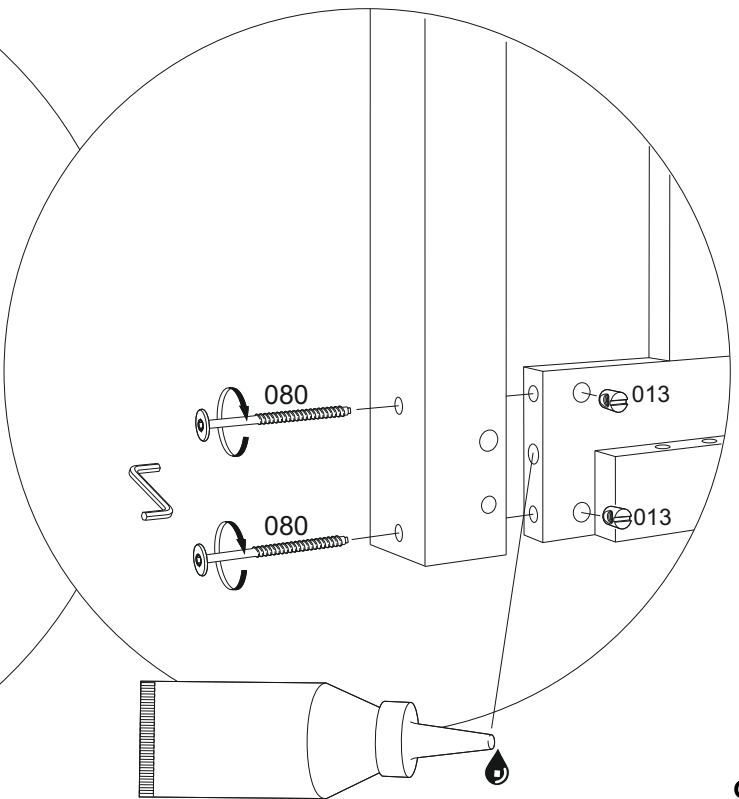
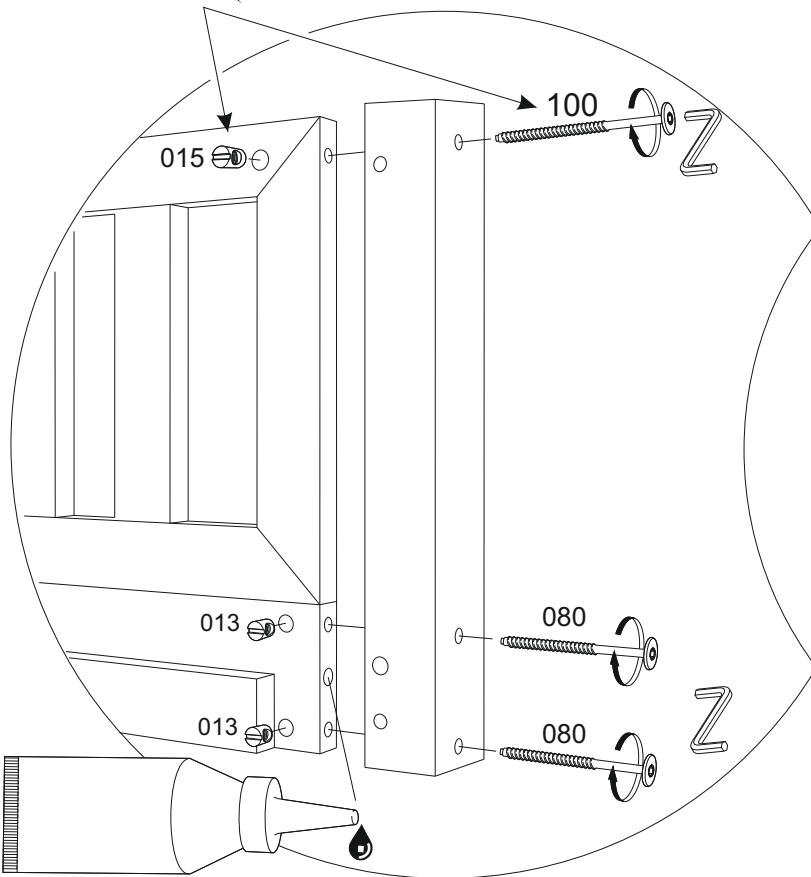
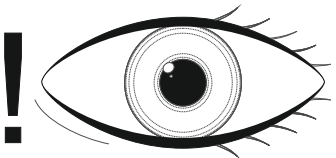
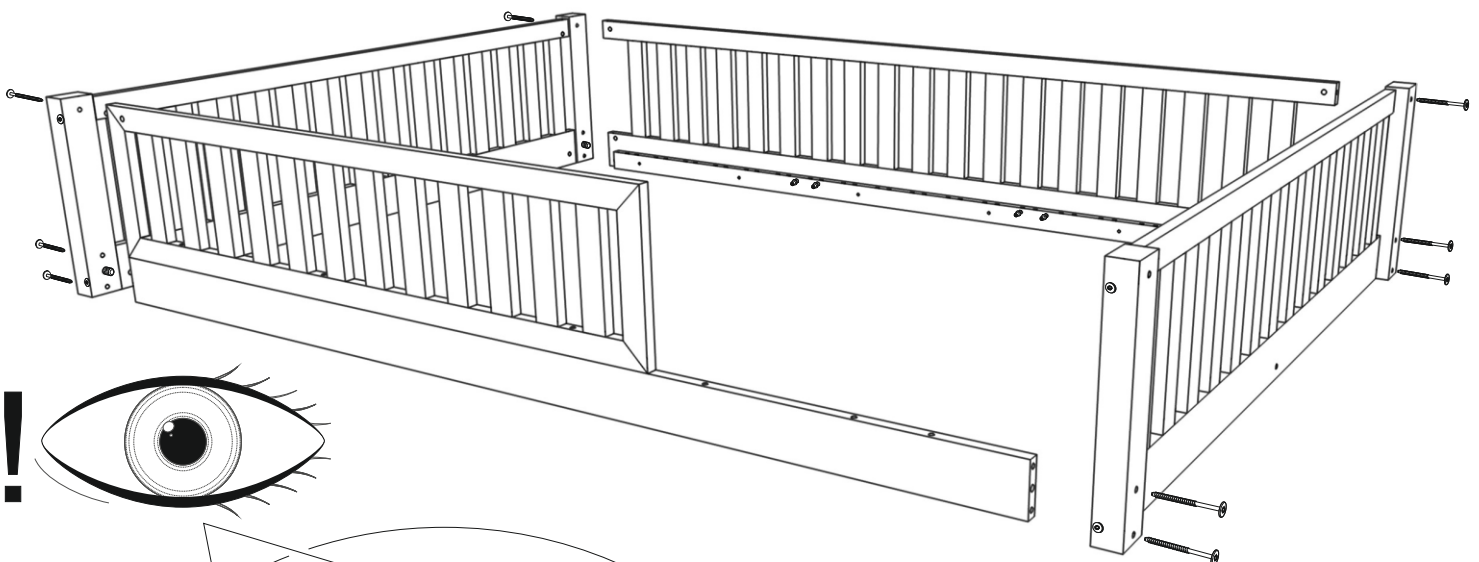
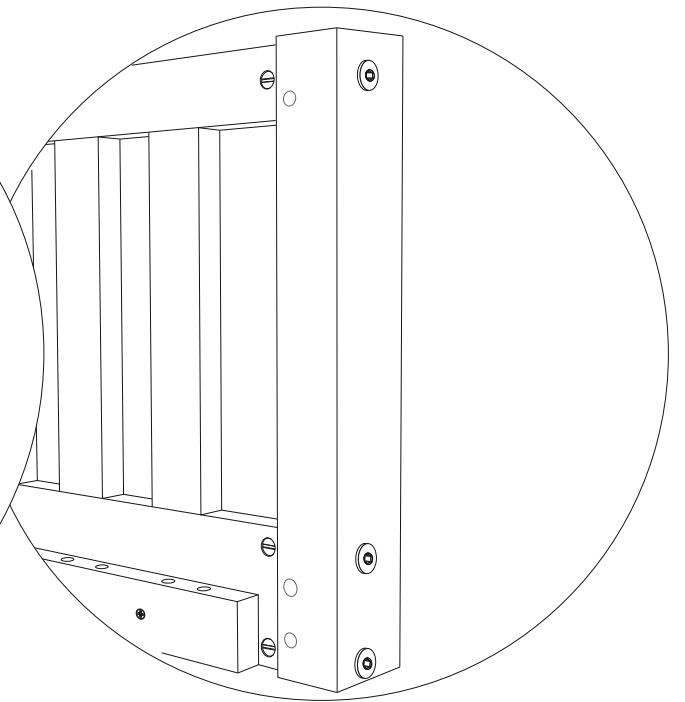
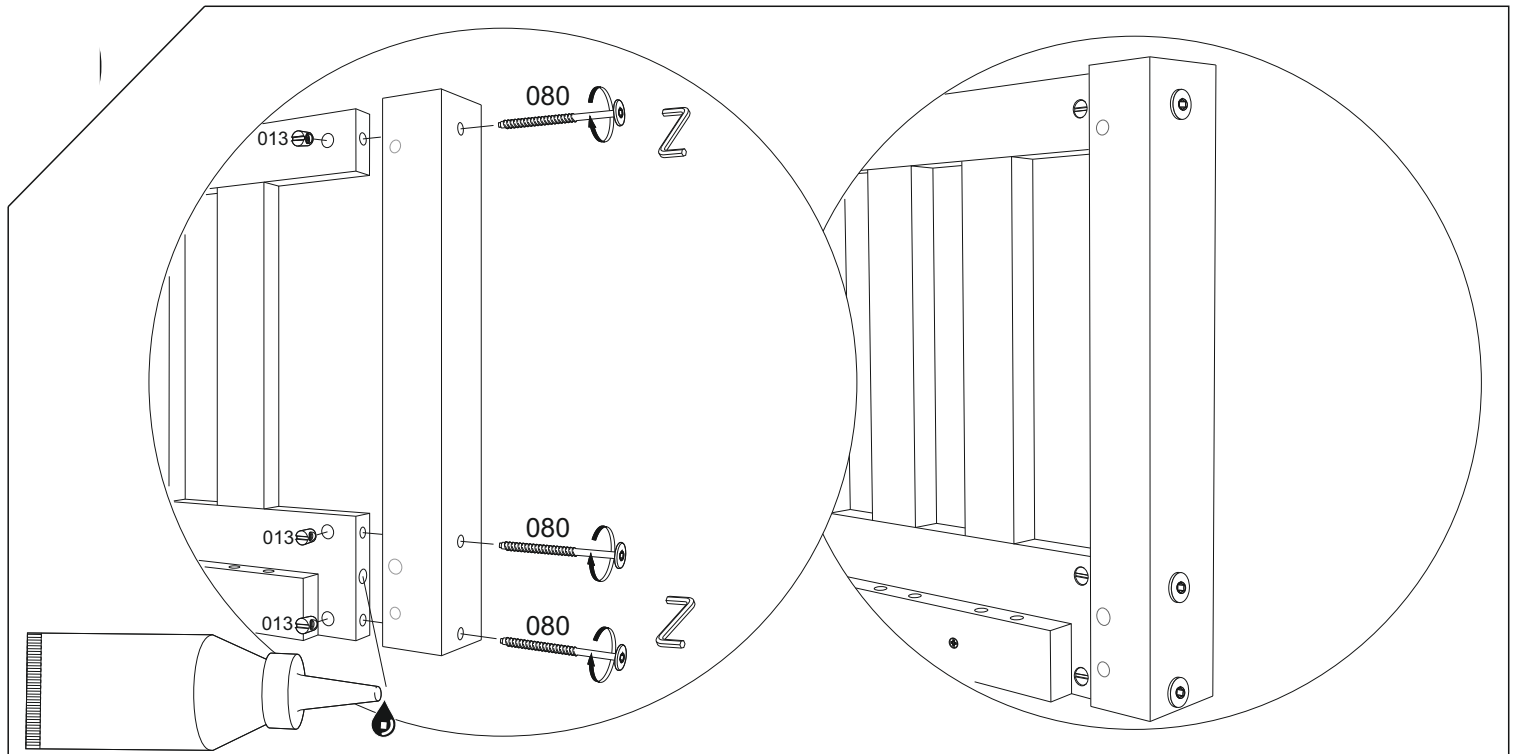

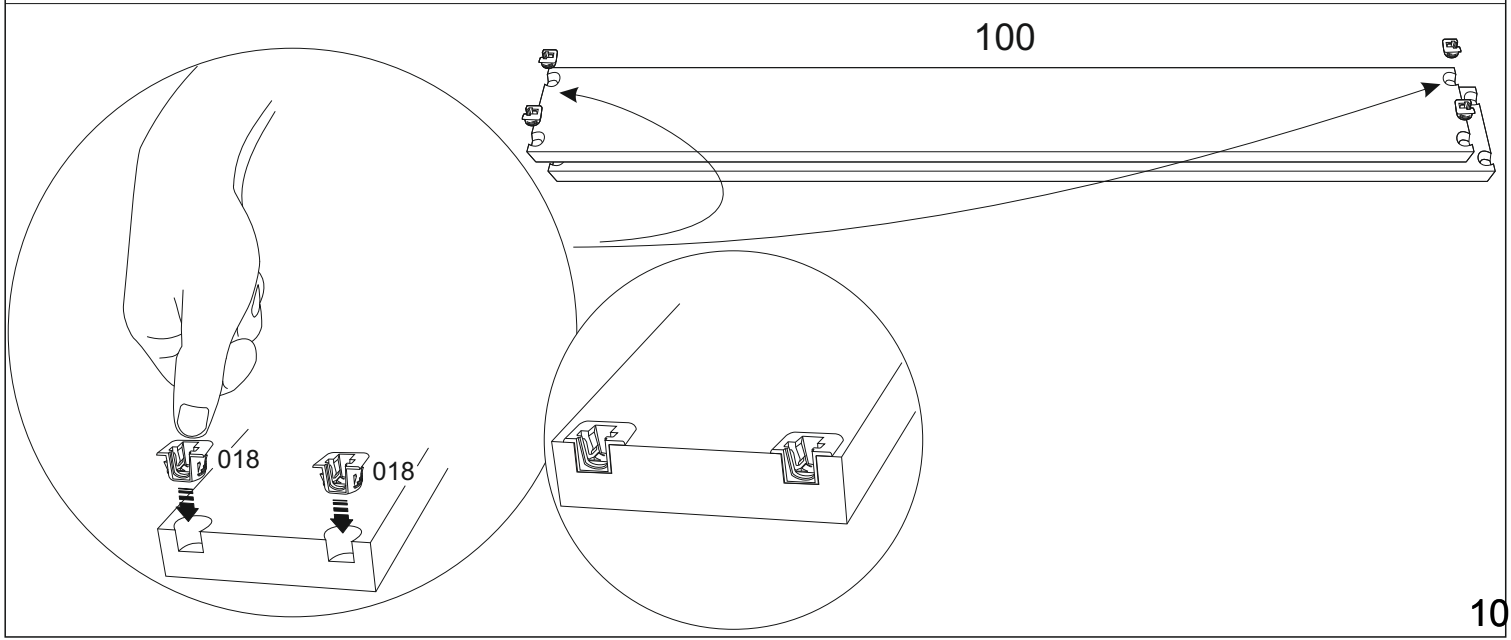
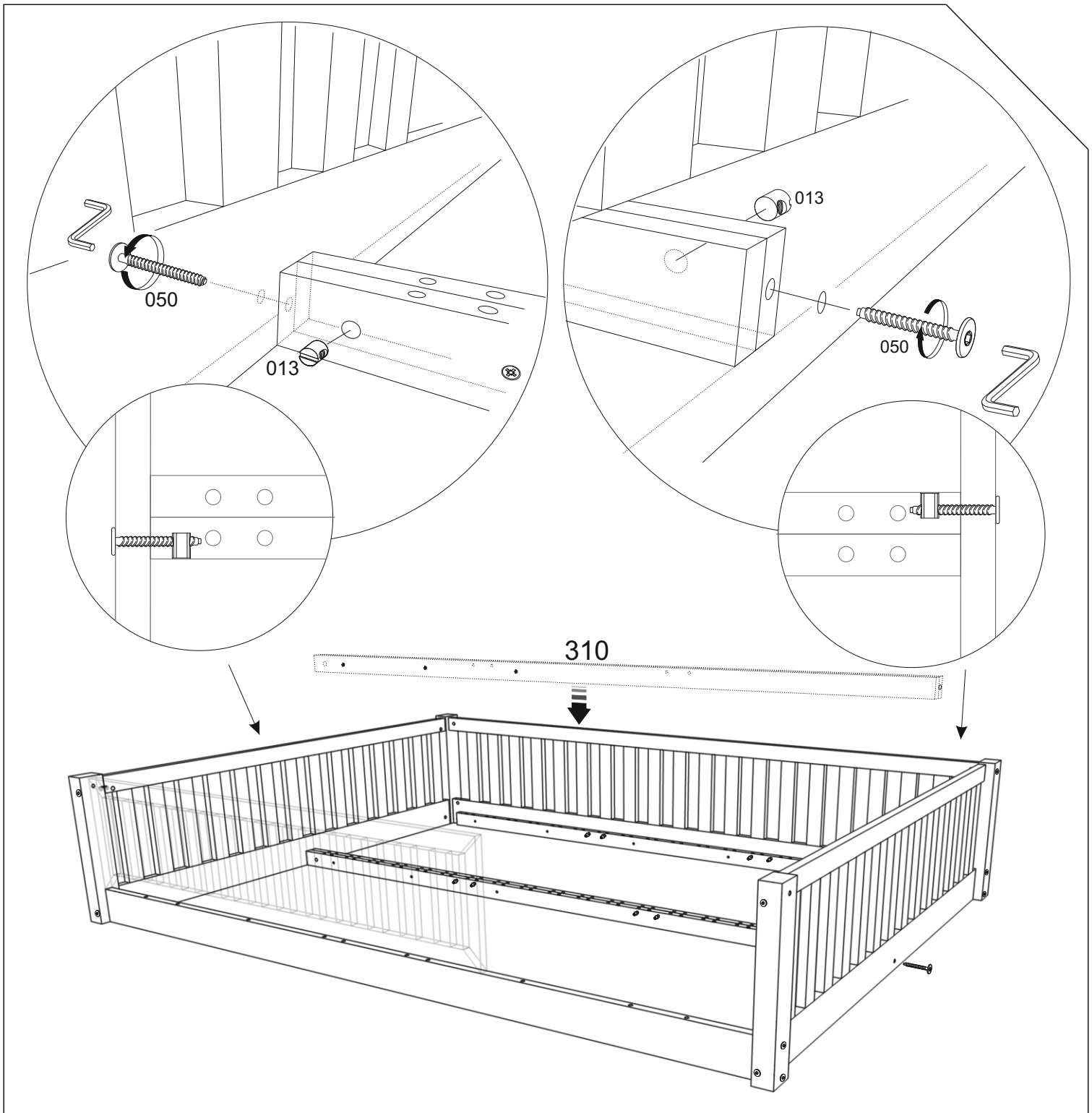

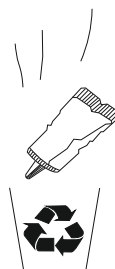
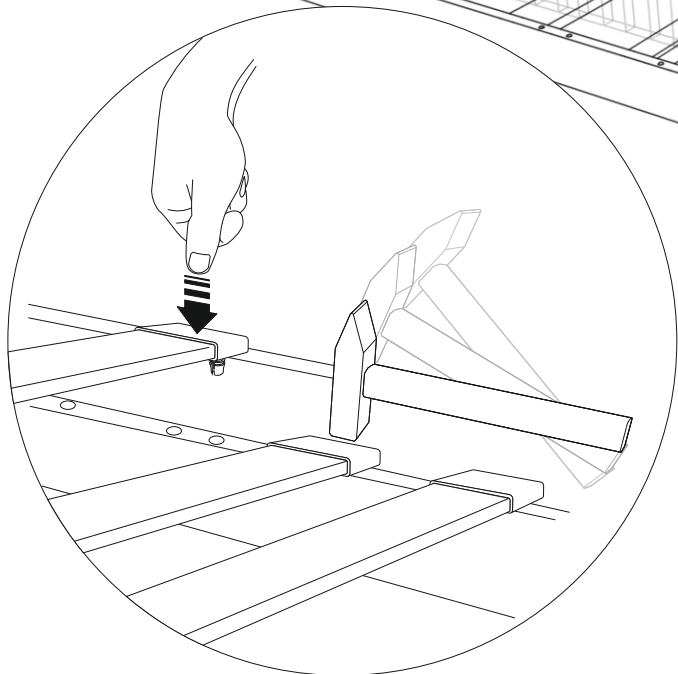
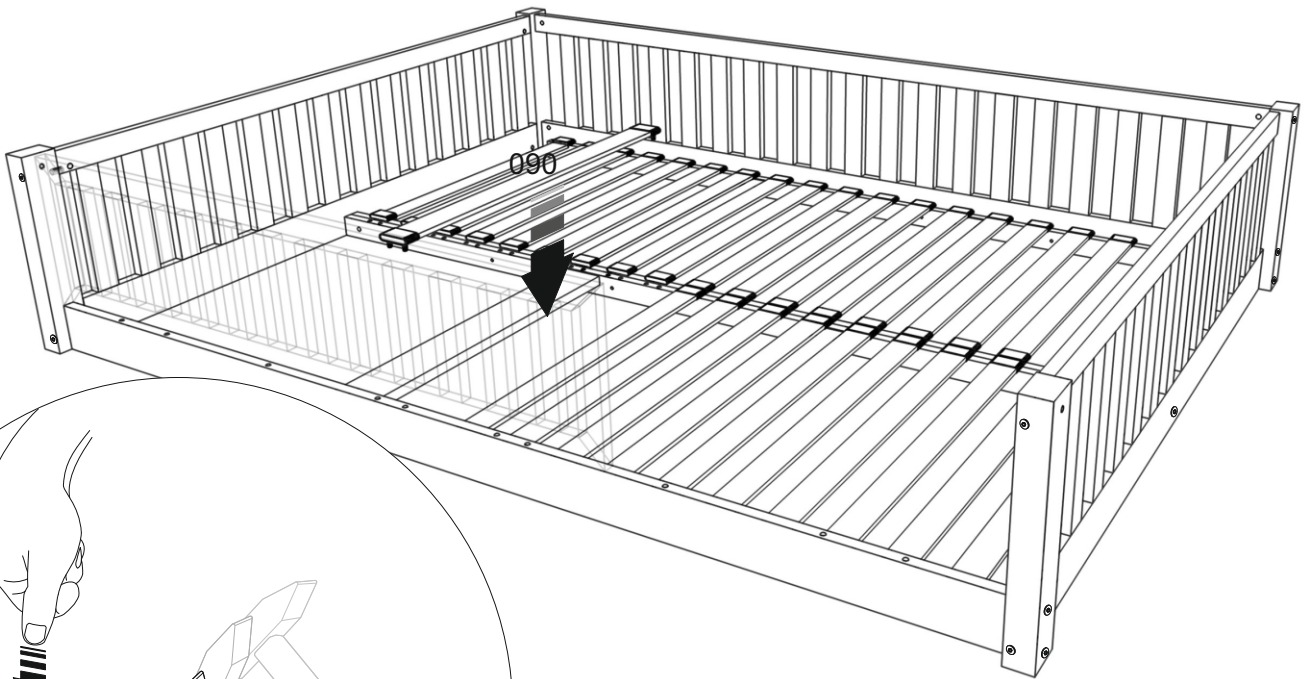
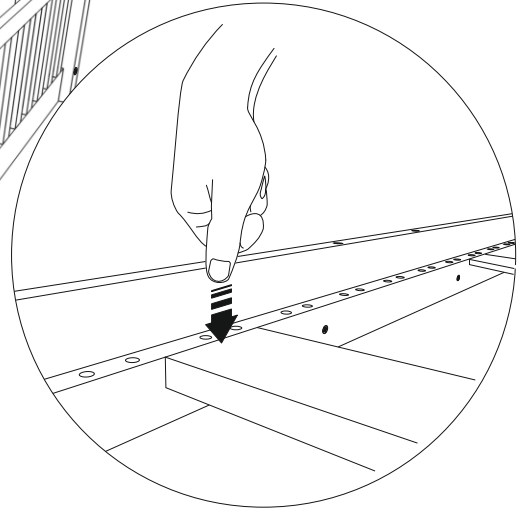
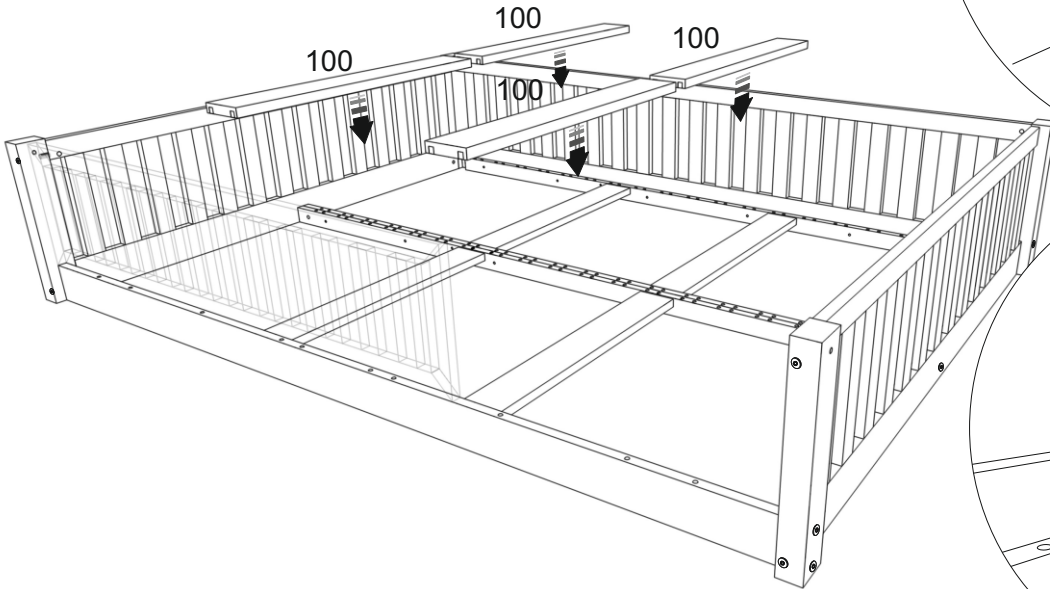
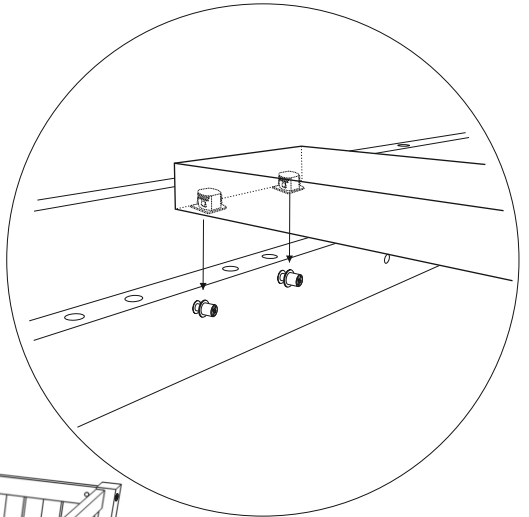
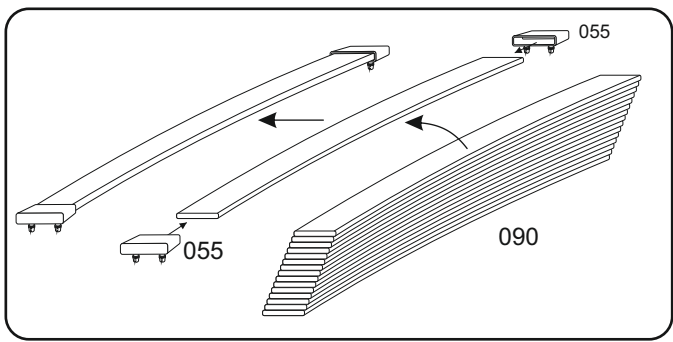

PLASTIC

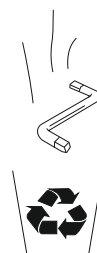

METAL



PAPER



IMPORTANT! KEEP FOR FUTURE REFERENCE: READ CAREFULLY.

- a. Warning: Be aware of the risks posed by open fire and other heat sources such as electric or gas heaters etc. near the bed.
- b. Warning: Do not use the bed if any part is damaged, torn or missing, use only the parts approved by the manufacturer.
- c. Warning: Do not leave anything in the bed or place the bed near any other equipment that could support the foot or pose a risk of suffocation or hanging the child, such as cords, curtain / blind cords.
- d. Warning: Do not use more than one mattress in the bed.
- e. Recommended maximum mattress thickness of 12 cm - 15 cm.
- f. The selected bed size is the size of the mattress to be used.
- g. It is recommended that all assembly elements be tightened well during assembly, regularly checked and tightened if necessary.



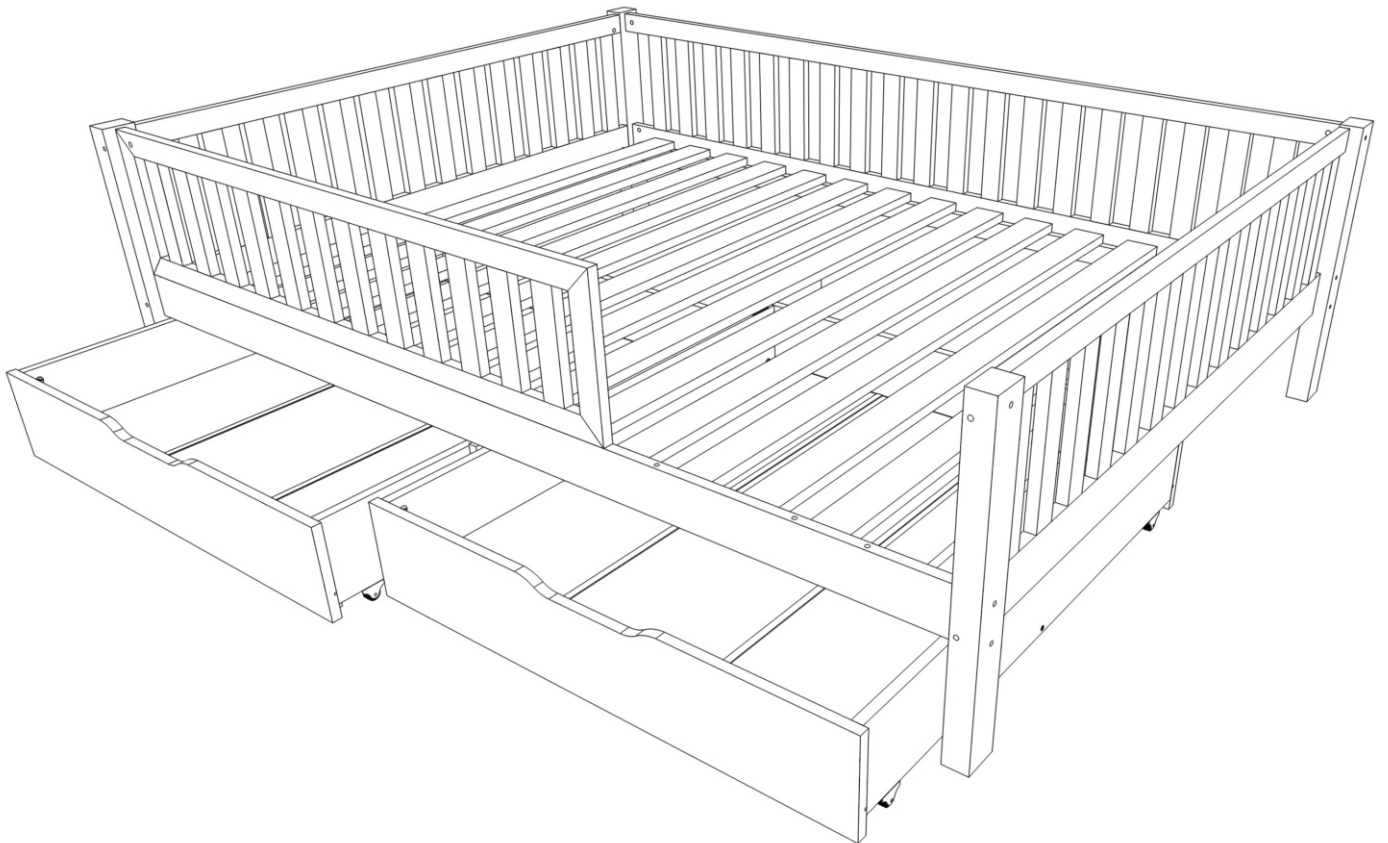
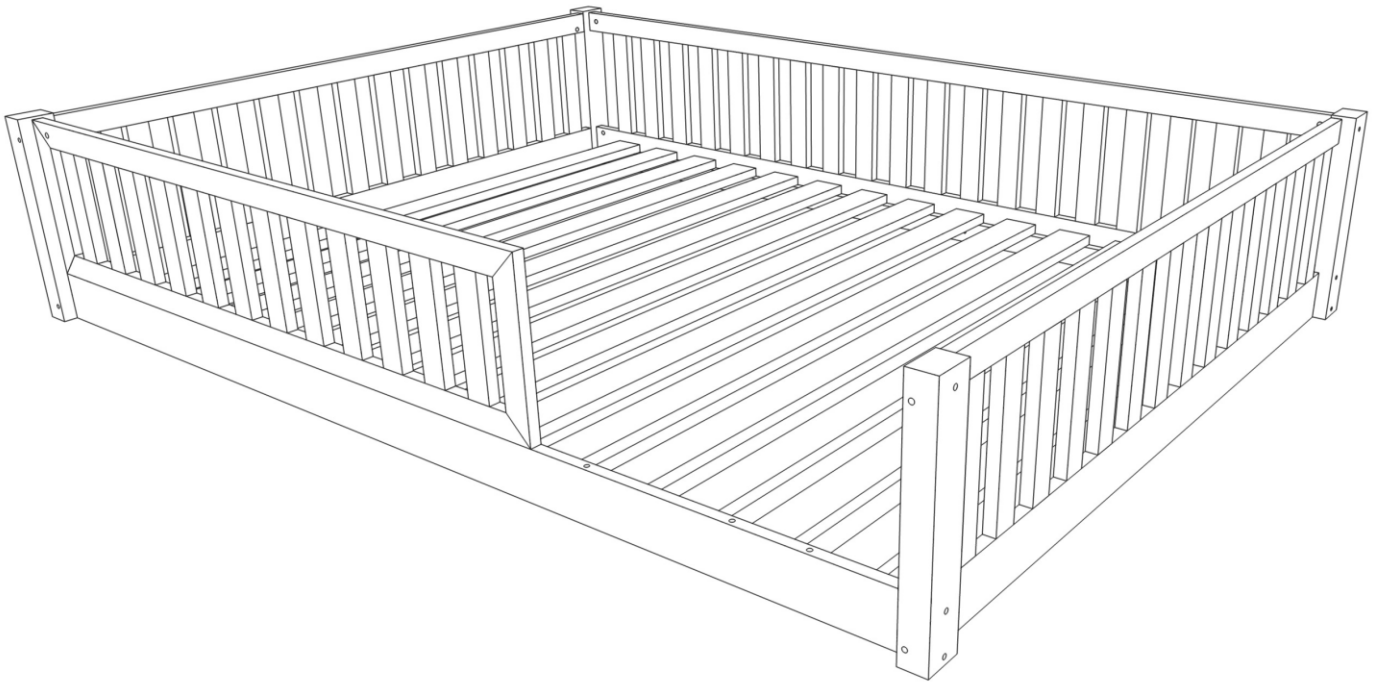

Warning: Before starting the assembly, please check all the elements. If any parts are damaged, please do not assemble the bed, and notify us of the damaged parts immediately by email, with photos, so that we can send you replacement parts. Once the bed has been assembled, any complaint regarding damages parts will no longer be accepted.

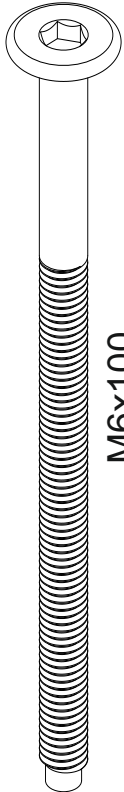

WICHTIG! FÜR SPÄTERES NACHSCHLAGEN AUFBEWAHREN: SORGFÄLTIG LESEN.

- a. Warnung: Seien Sie sich der Risiken bewusst, die durch offenes Feuer und andere Wärmequellen wie Elektro- oder Gasheizungen usw. in der Nähe des Bettes entstehen.
- b. Warnung: Verwenden Sie das Bett nicht, wenn Teile beschädigt, gerissen oder fehlen, verwenden Sie nur die vom Hersteller zugelassenen Teile.
- c. Warnung: Lassen Sie nichts im Bett liegen und stellen Sie das Bett nicht in die Nähe anderer Geräte, die den Fuß stützen oder eine Erstickungsgefahr oder das Aufhängen des Kindes darstellen könnten, wie z.B. Drähte, Gardinen-/Rolloschnüre.
- d. Warnung: Verwenden Sie nicht mehr als eine Matratze im Bett.
- e. Empfohlene maximale Matratzendicke von 12 cm - 15 cm.
- f. Die gewählte Bettgröße ist die Größe der zu verwendenden Matratze.
- g. Es wird empfohlen, alle Montageelemente während der Montage gut anzuziehen, regelmäßig zu kontrollieren und ggf. nachzuziehen.

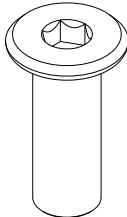
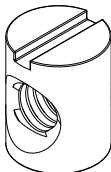
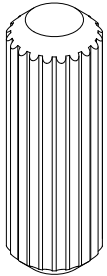
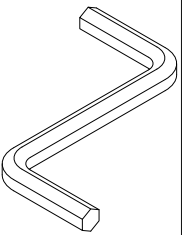
Achtung: Bitte prüfen Sie vor dem Aufbau ob Sie alle Elemente erhalten haben. Sollten einige Teile beschädigt sein, bitten wir Sie das Bett vorerst nicht aufzubauen und uns die Schäden schriftlich zu melden. Wir werden diese schnellstens ersetzen. Sollte das Bett bereits aufgebaut worden sein, so kann die Reklamation nicht akzeptiert werden.

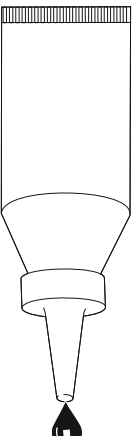
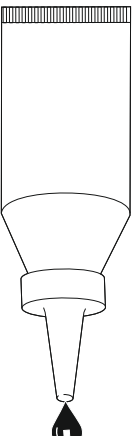
120	100	080	025	013	010	050	002
							
M6x120	M6x100	M6x80	3-4X	18x	8x	2x	
			015				001
							
3-4x	9x	10x	1x				

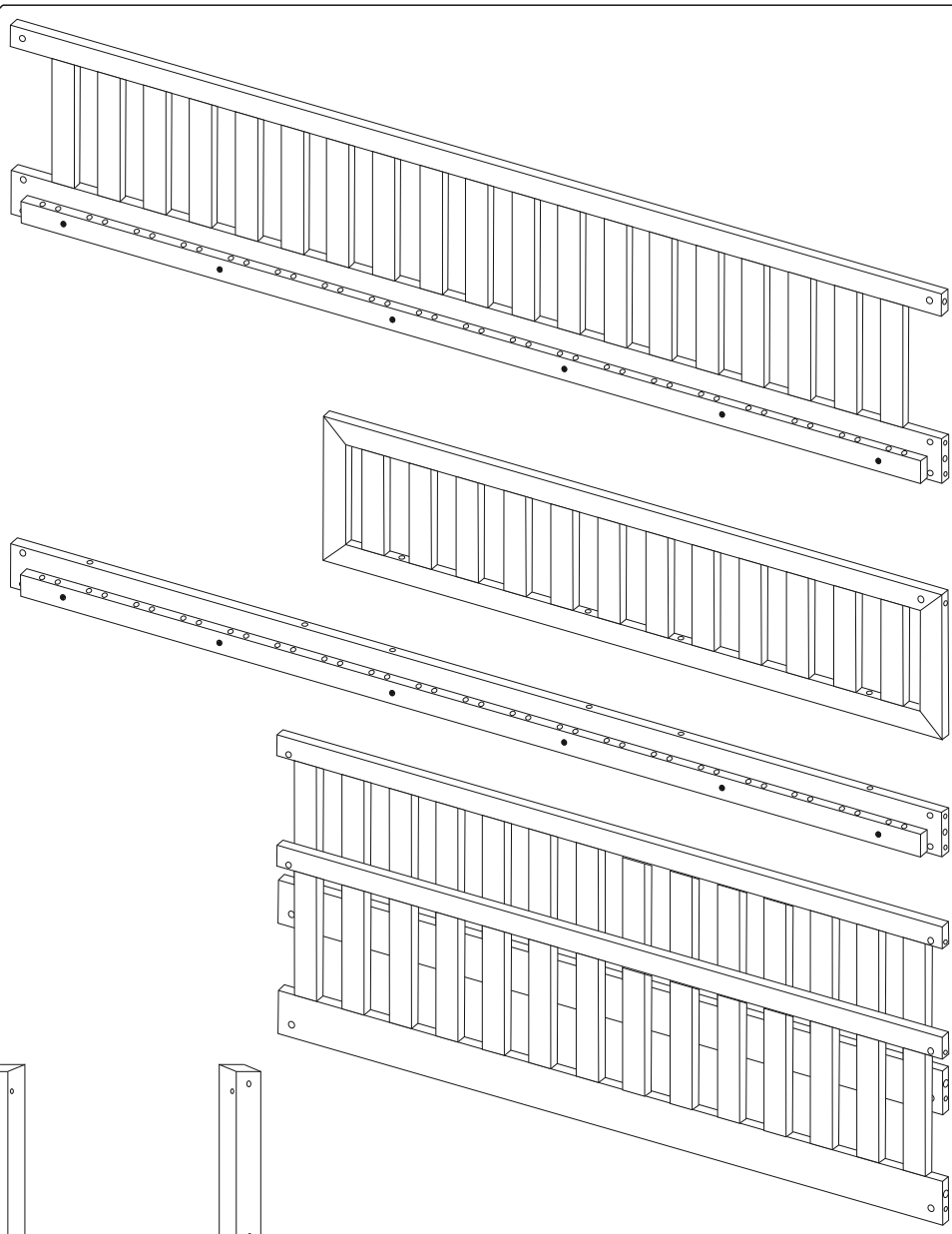

BAP20

BAP21

BAP22

BAP24

BAP24

BAP02

BAP03

BAP01

BAP04

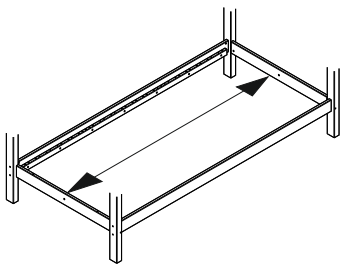

190 cm

200 cm

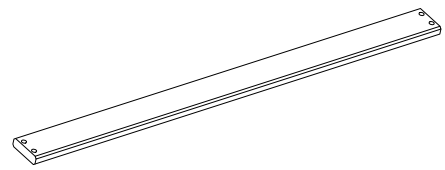

14x

15x

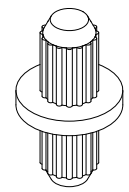

56x

60x

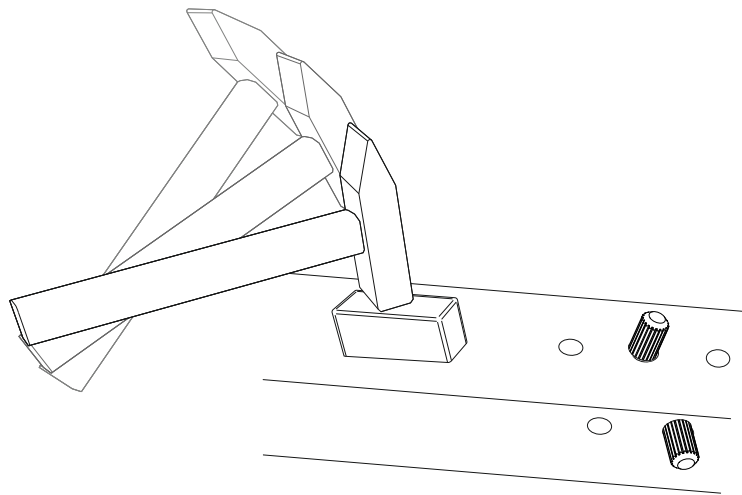
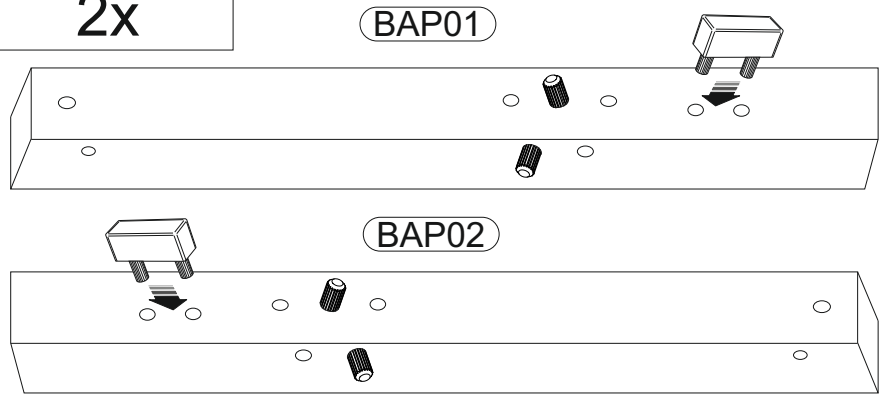
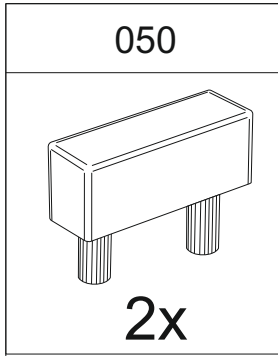
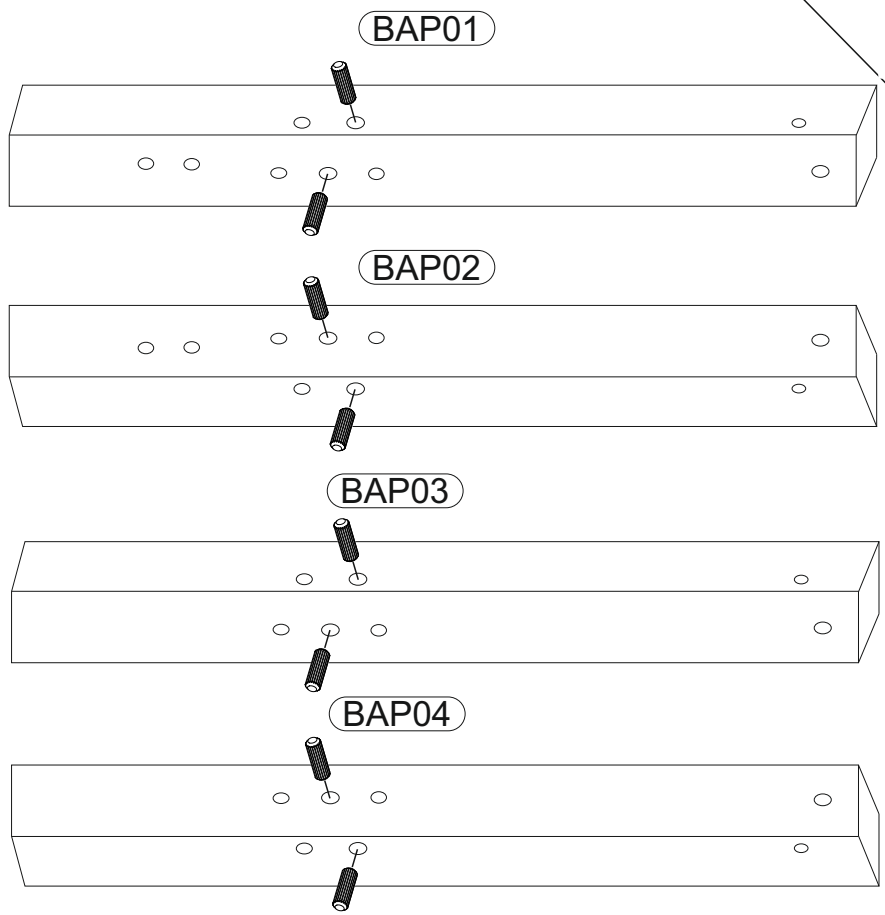
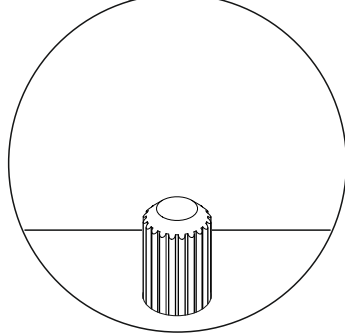
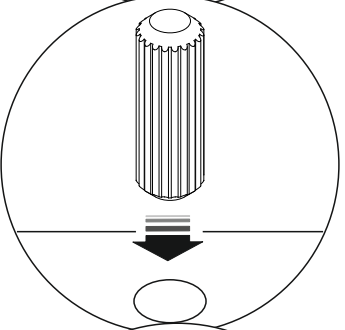
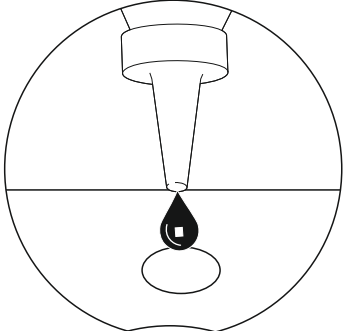
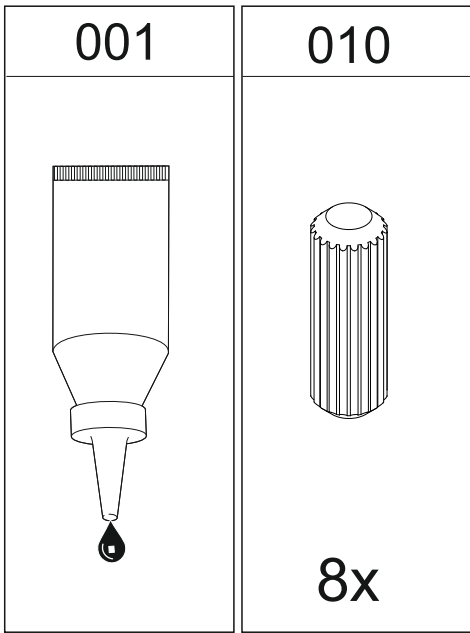

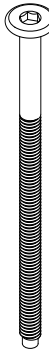
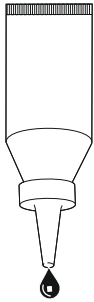
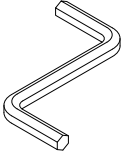

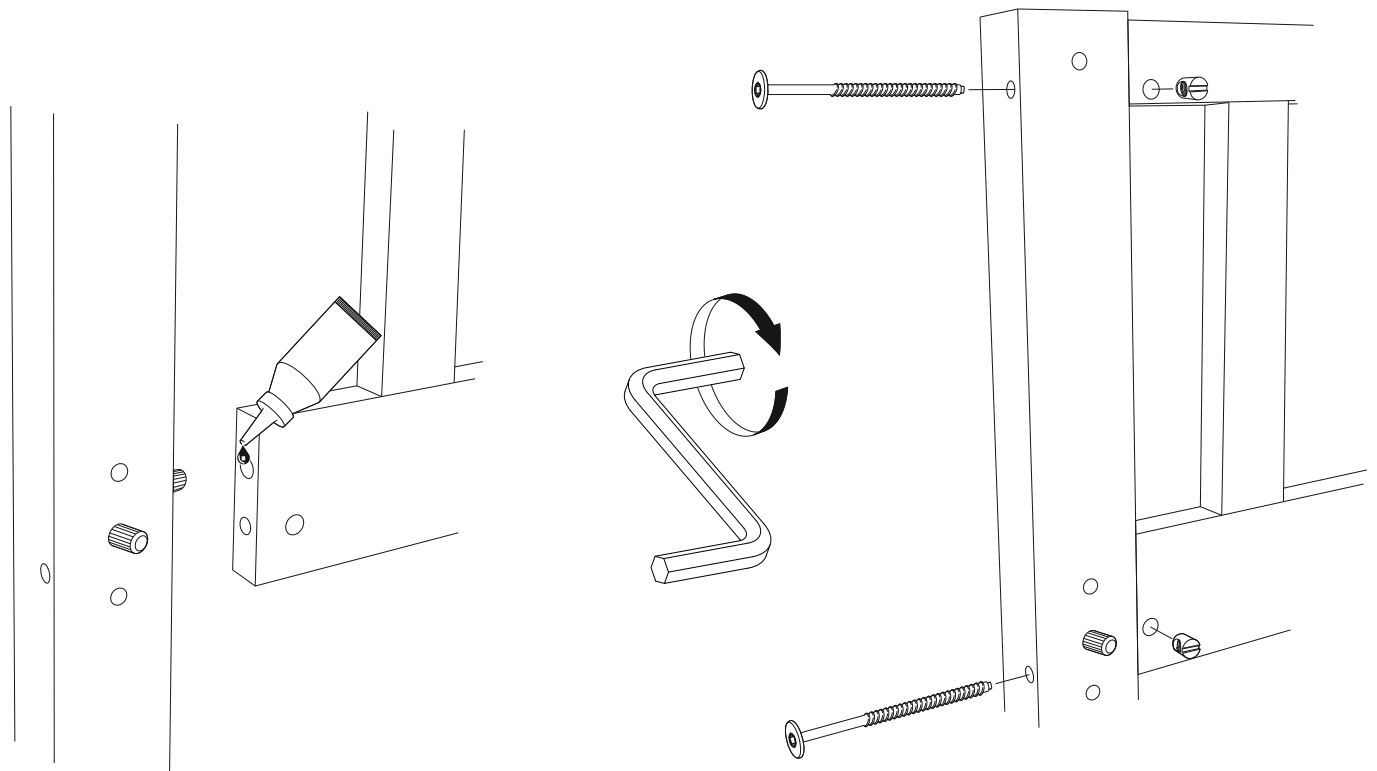
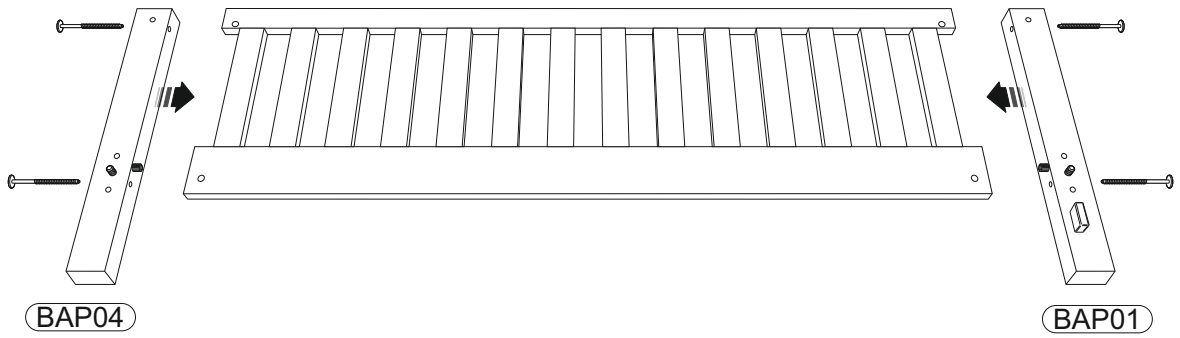
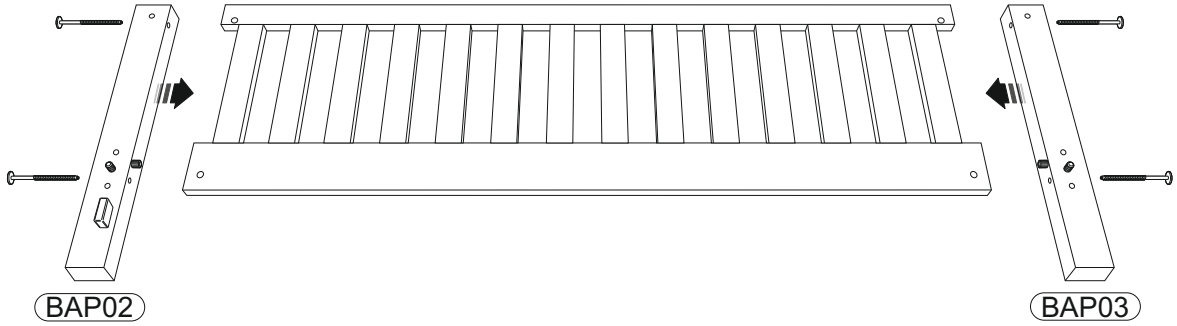

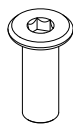
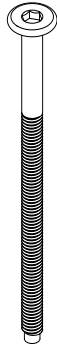
014	100	001	002
			
8x	8x		

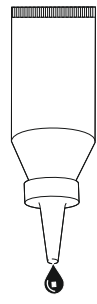
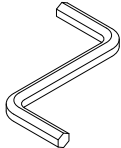

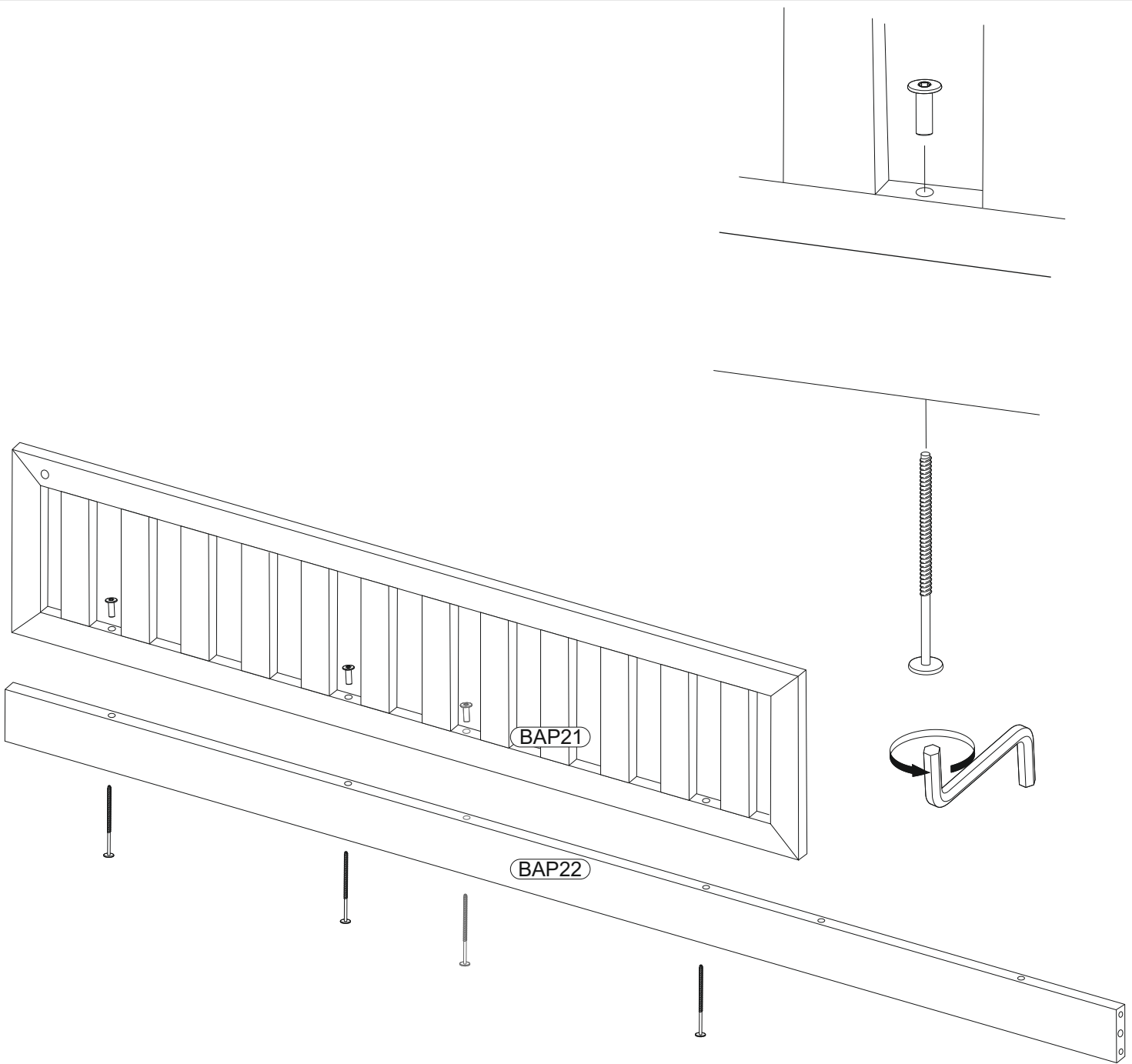
025		120	
			
190cm	200cm	190cm	200cm
3x	4x	3x	4x

001	002
	

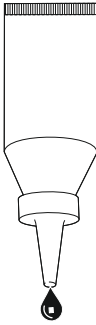
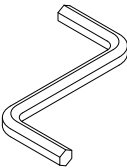

015 *	100 *	014	080	001	002
					
1x	1x	10x	10x		

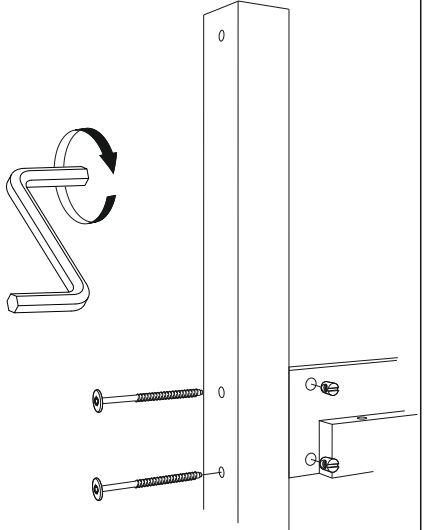
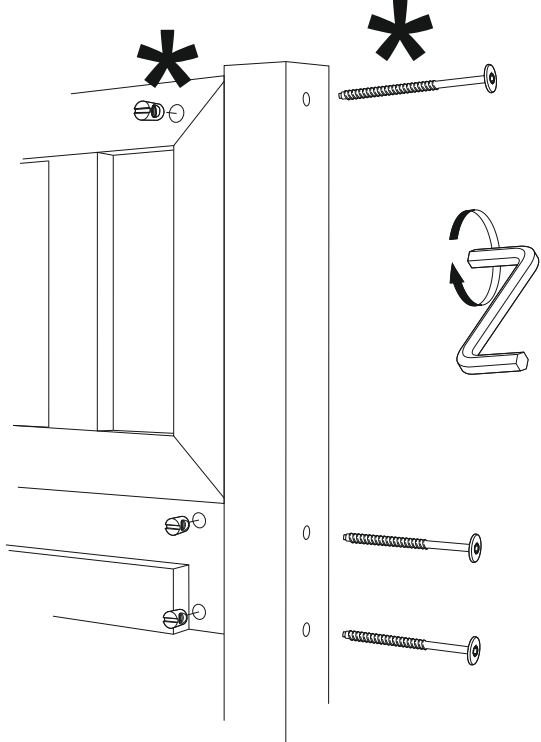
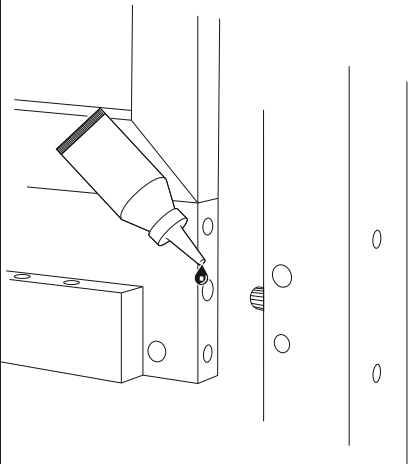
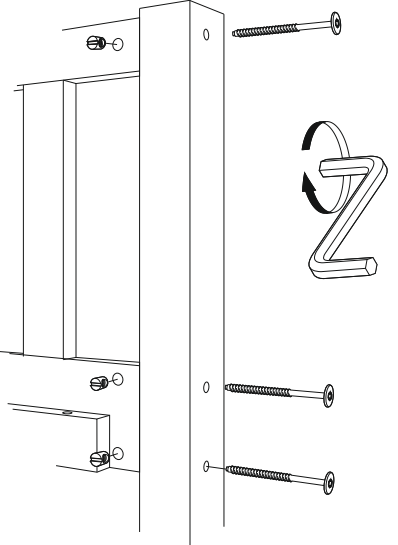
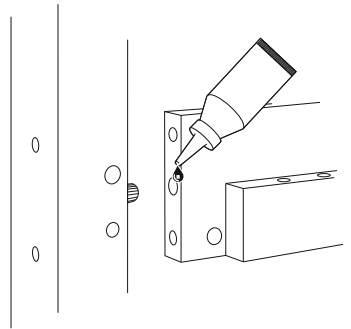
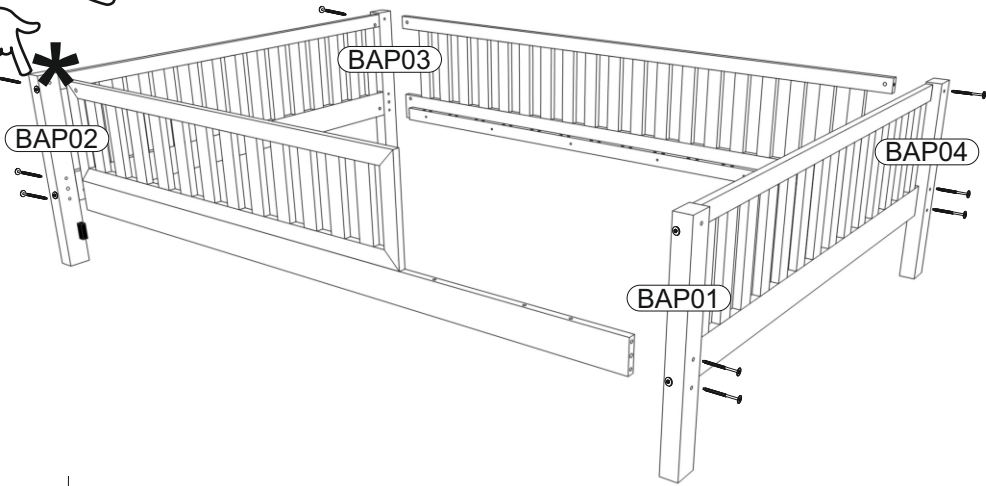

096

097

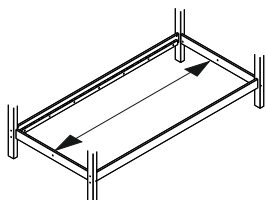
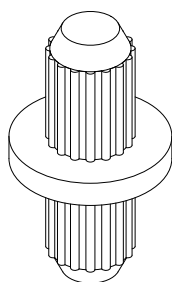
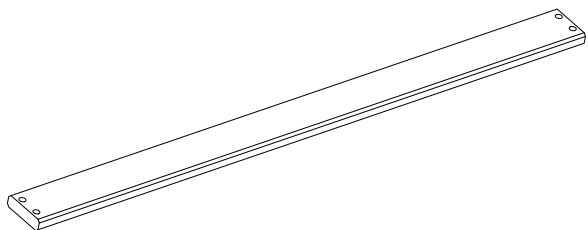

190 cm

14x

56x

200 cm

15x

60x

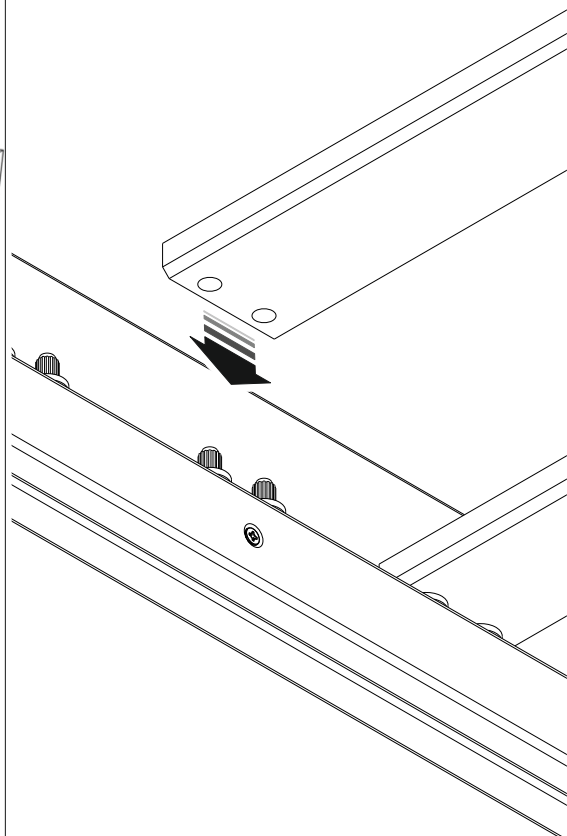
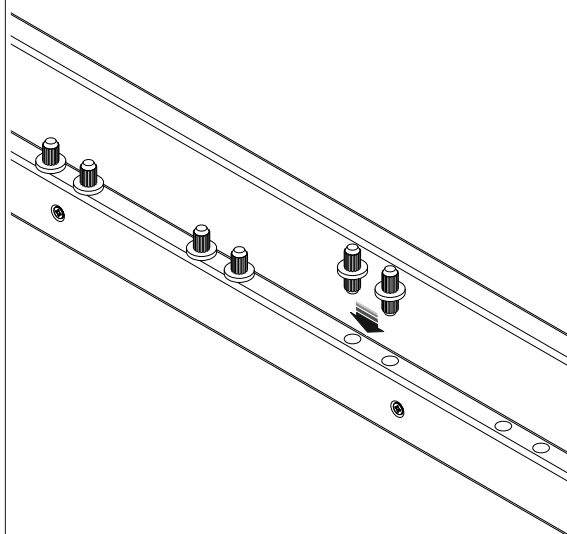
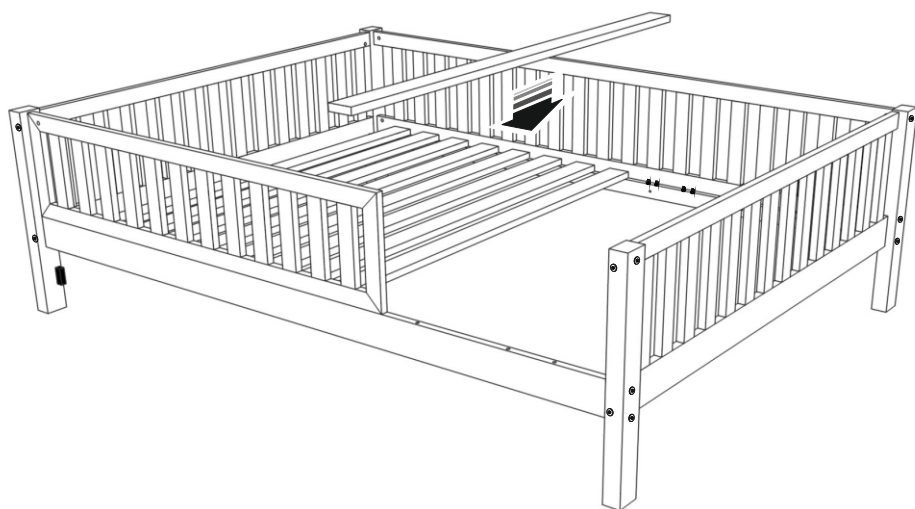

Drawer assembly instructions

B 6-9

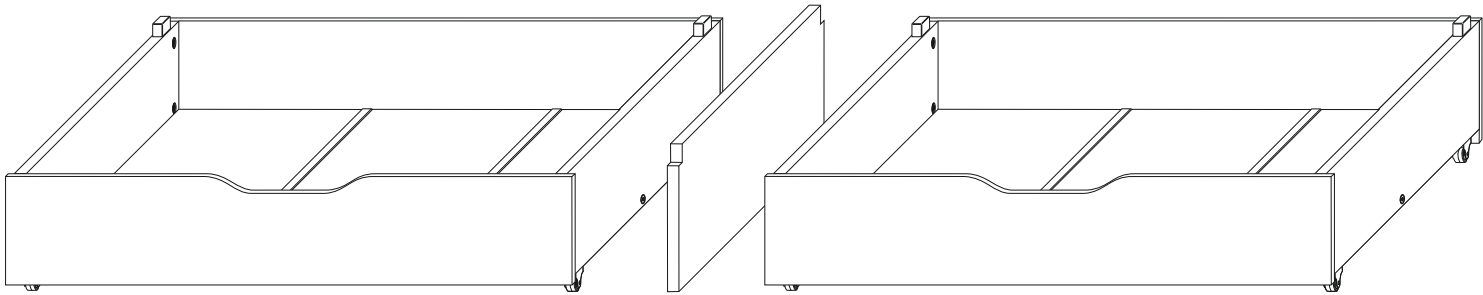

PAPER

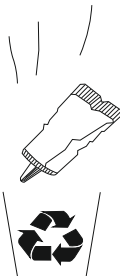

PLASTIC

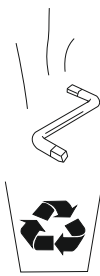

METAL

B 6

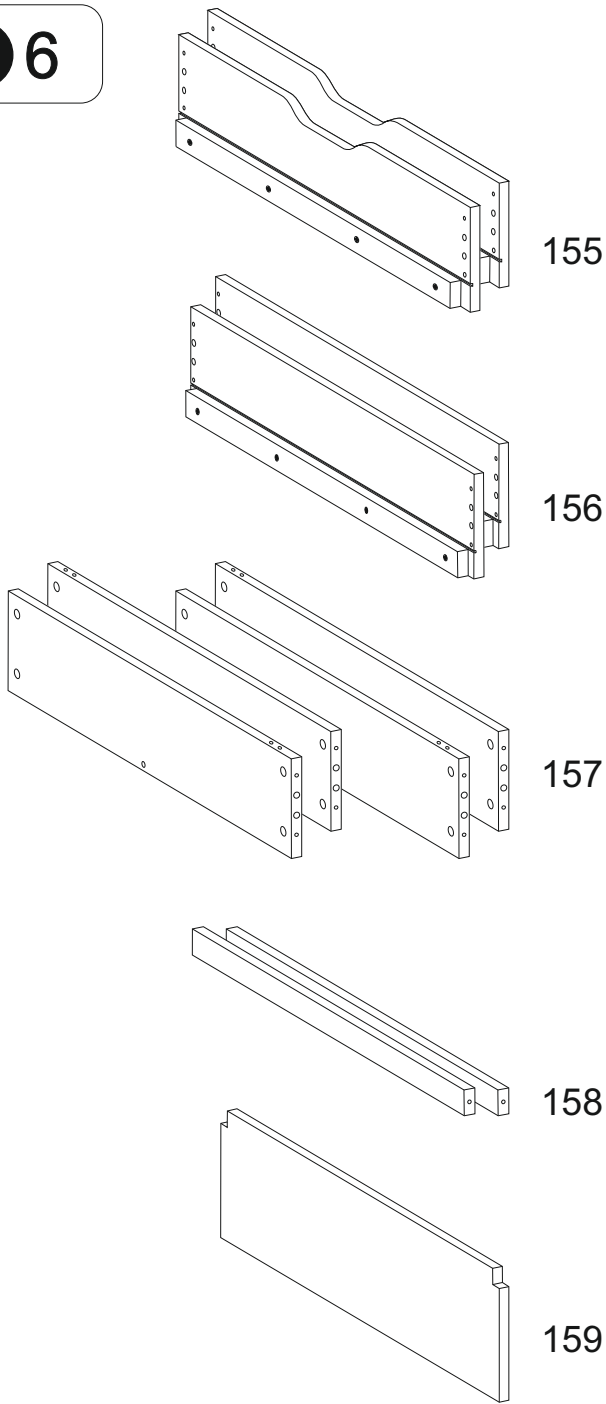

075 4x	042 16x	016 24x
014 16x	028 8x	030 16x
018 4x	050 4x	001 1x
152 6x	153 4x	002 1x

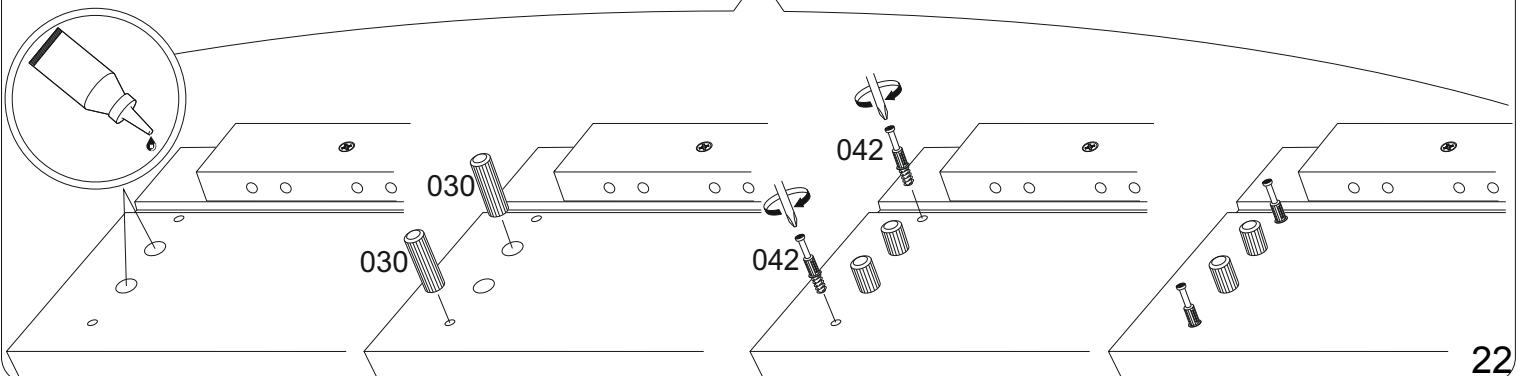
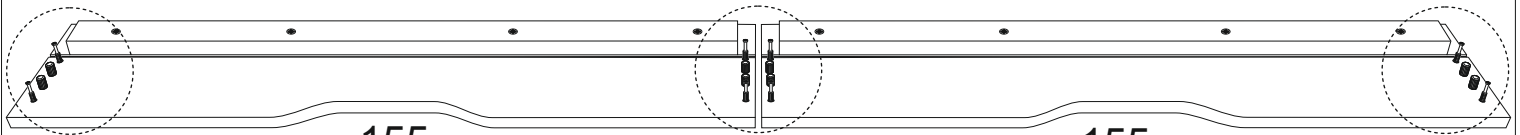
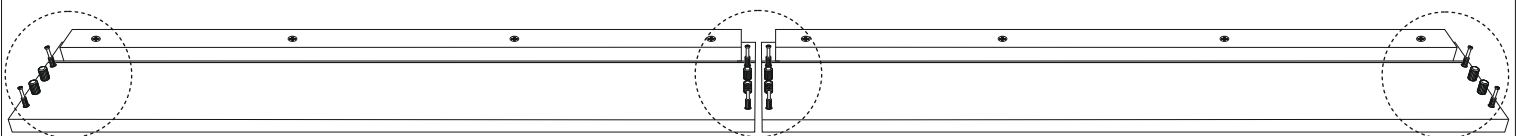

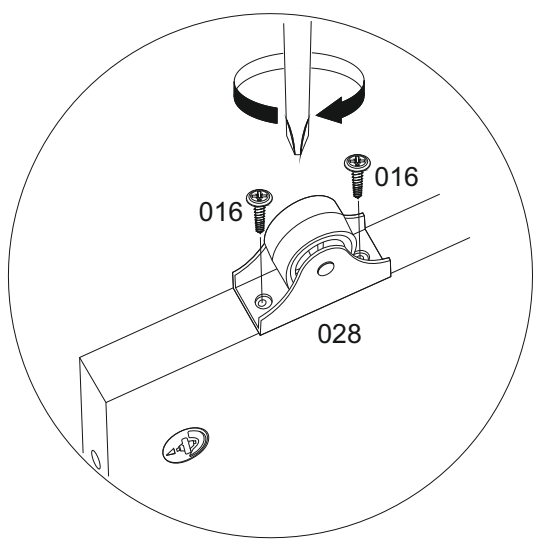
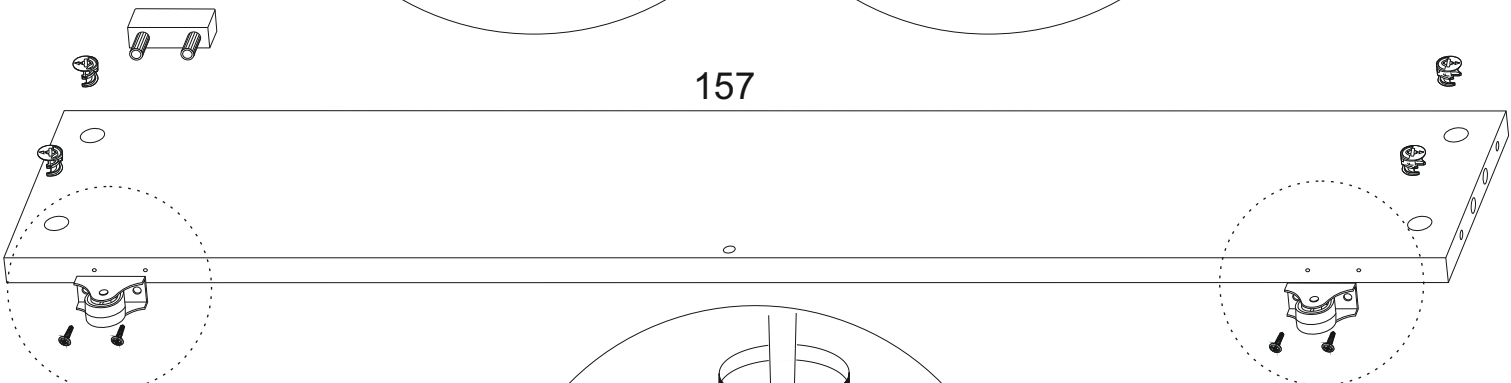
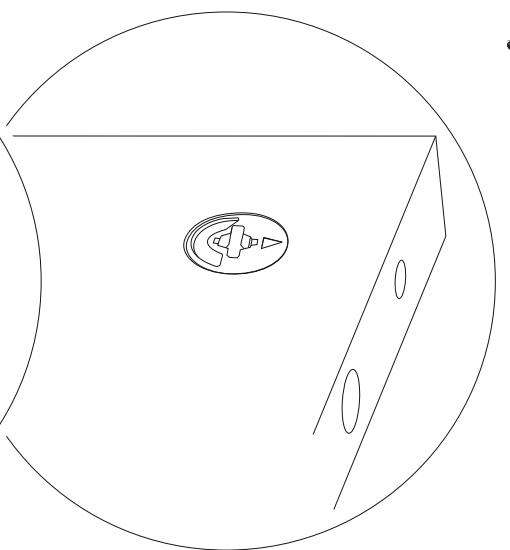
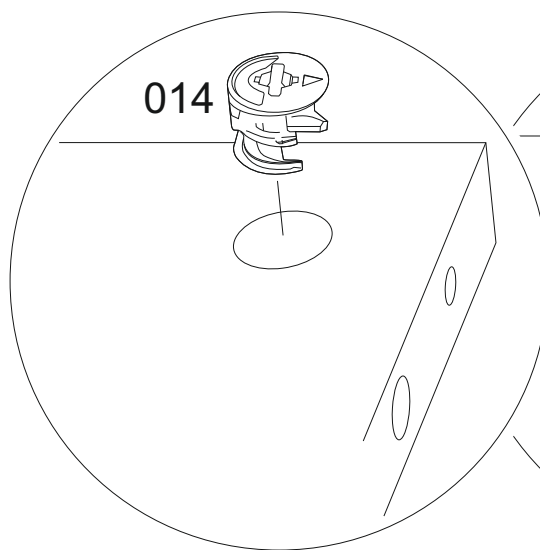
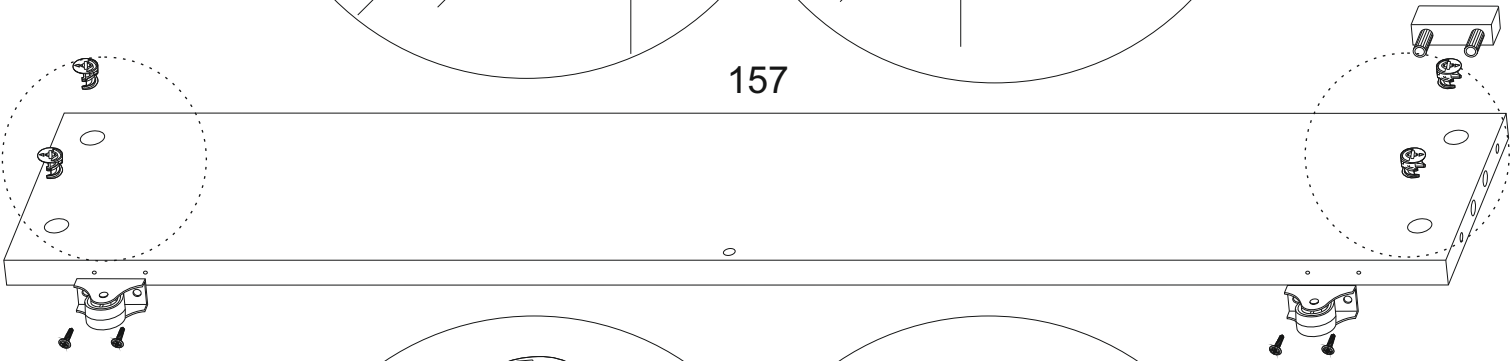
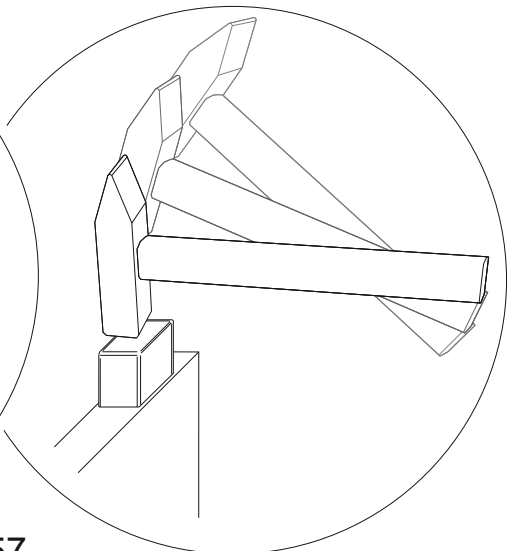
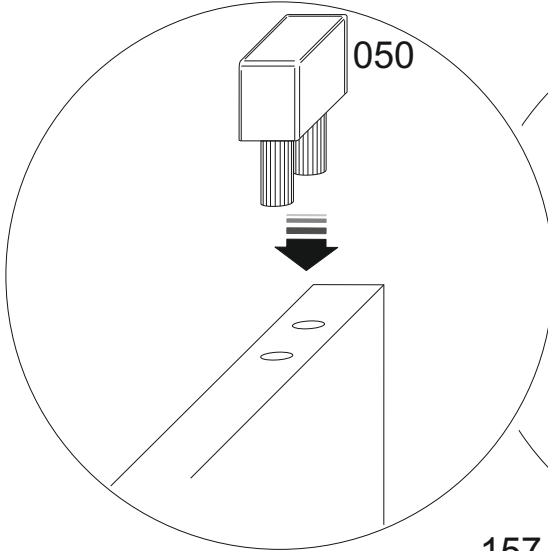

B 8

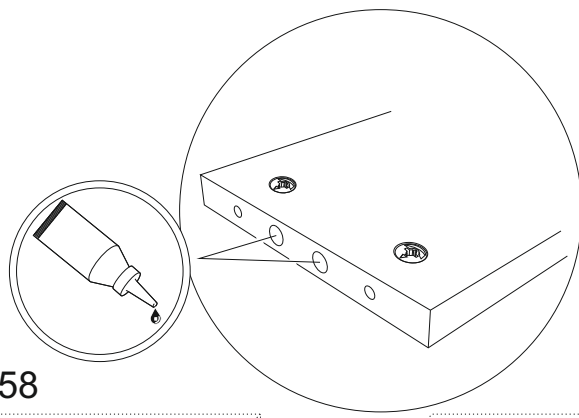

158

158

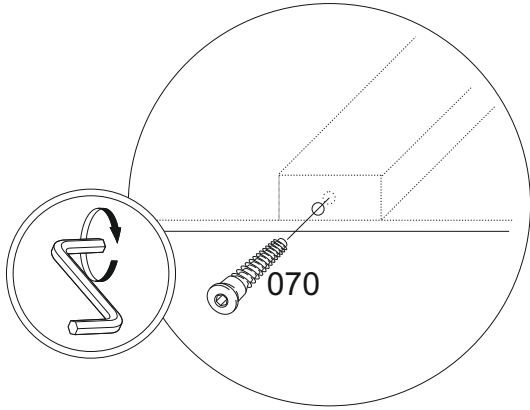
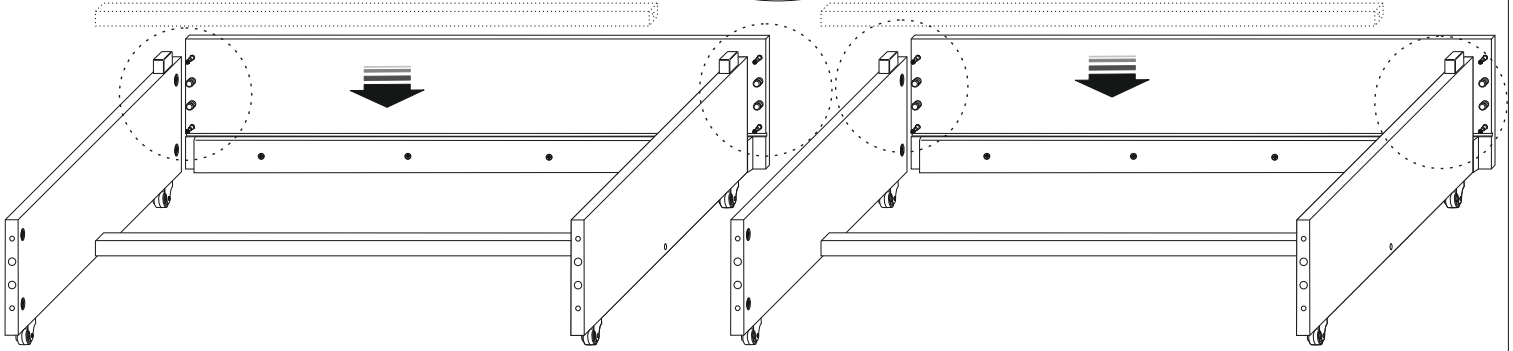

070

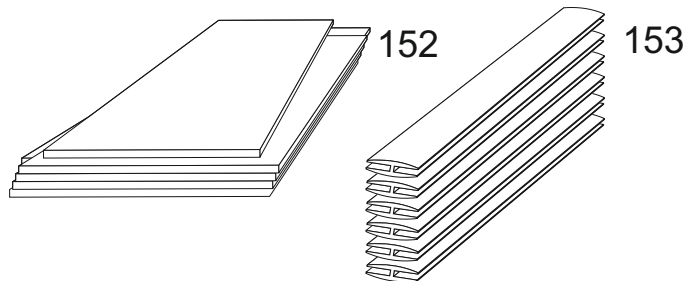
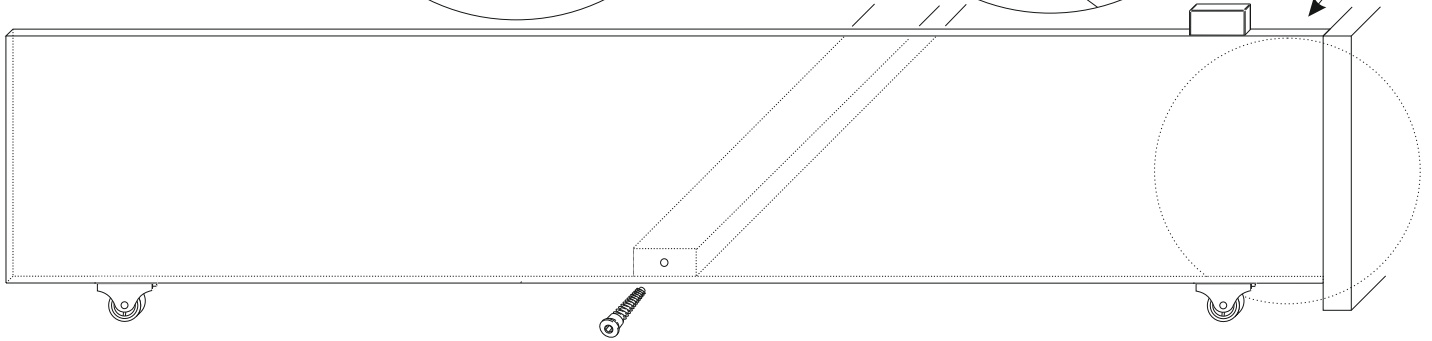
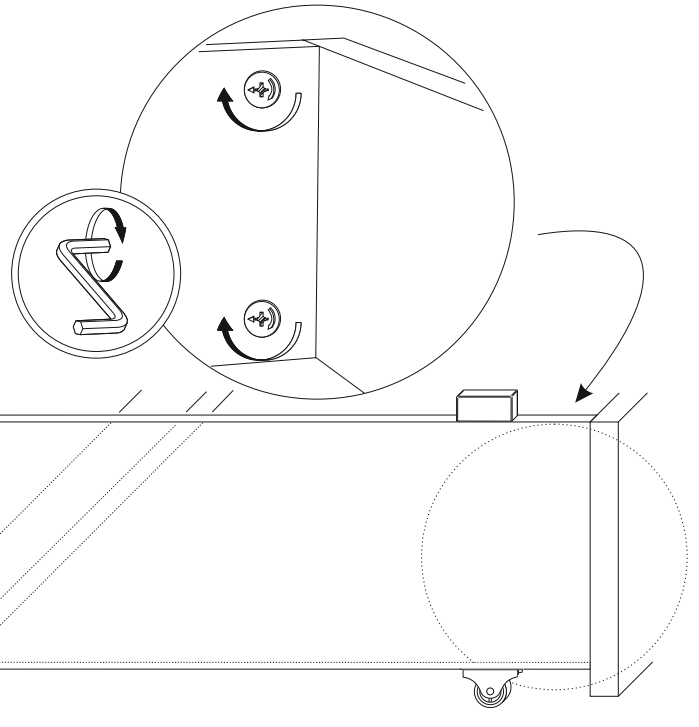

152

153

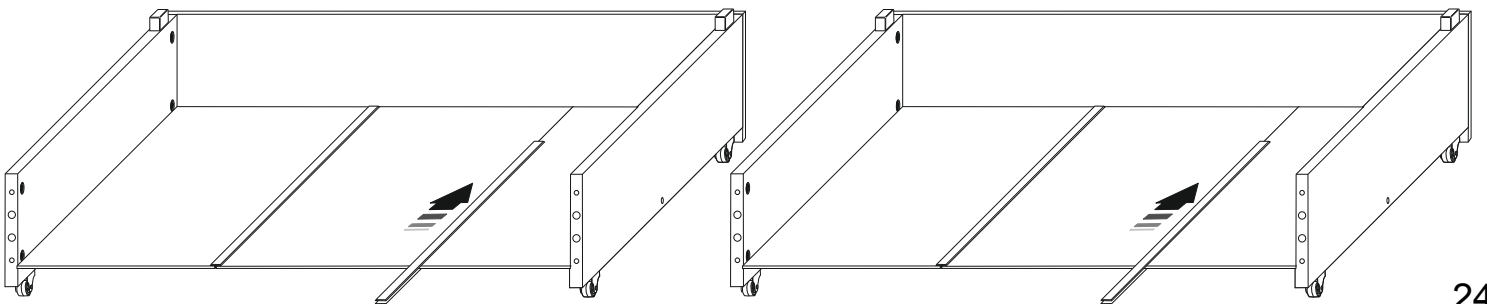

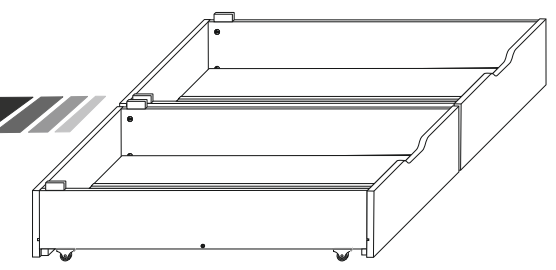
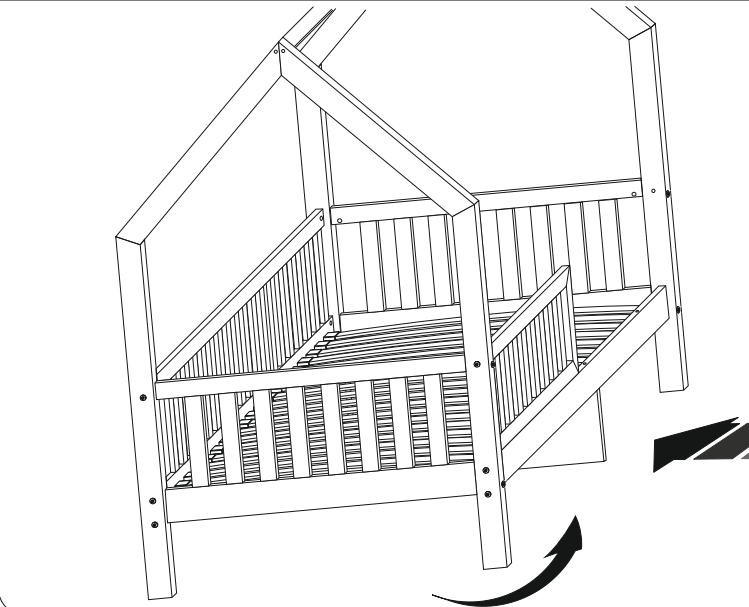
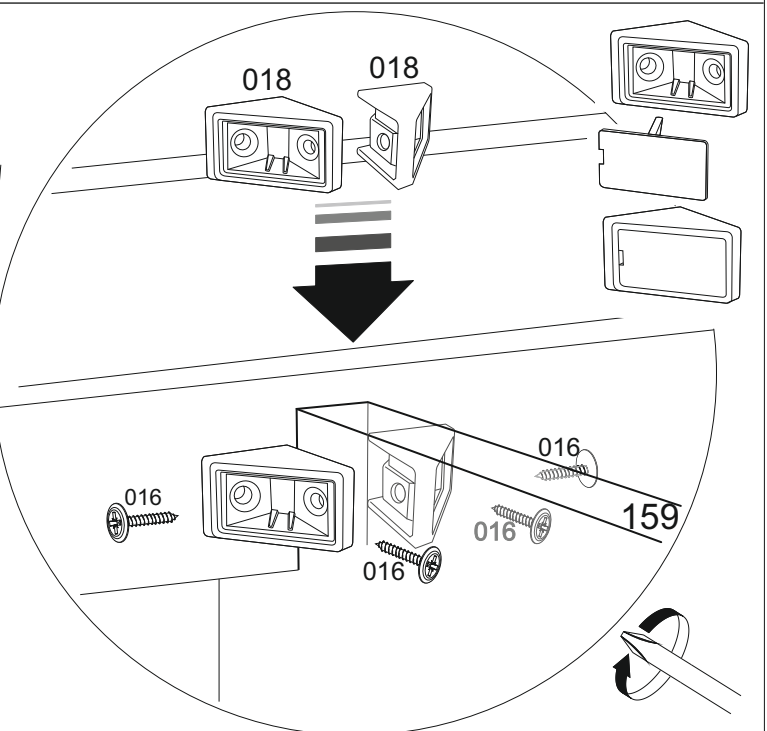
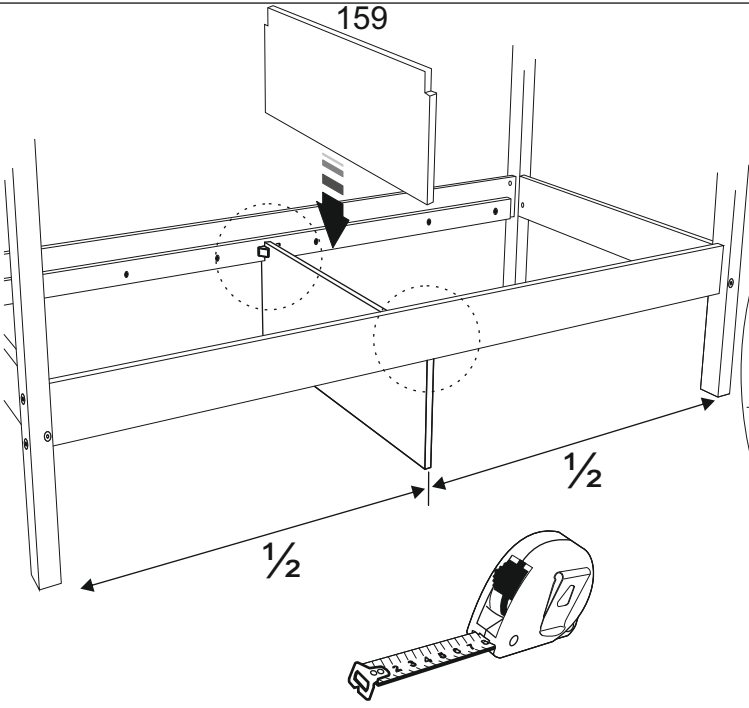
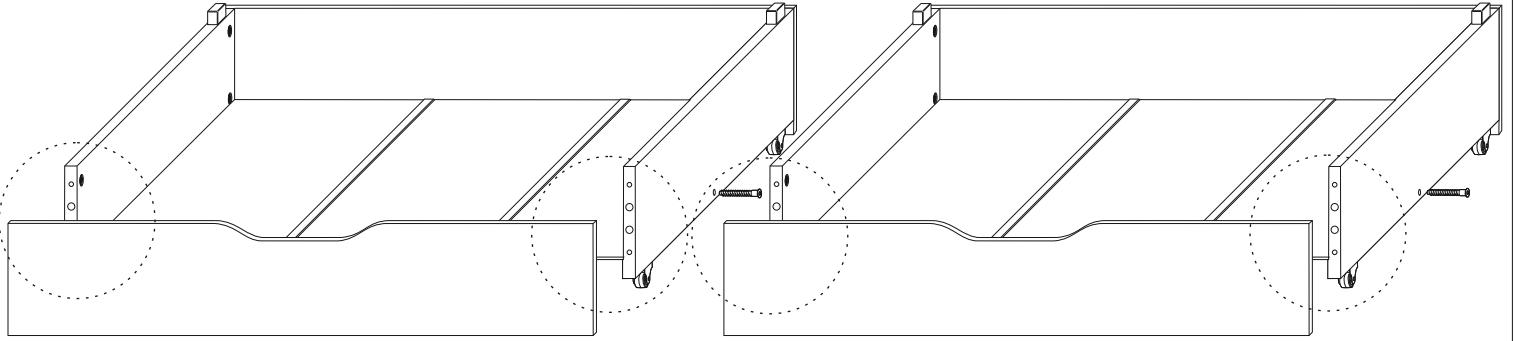
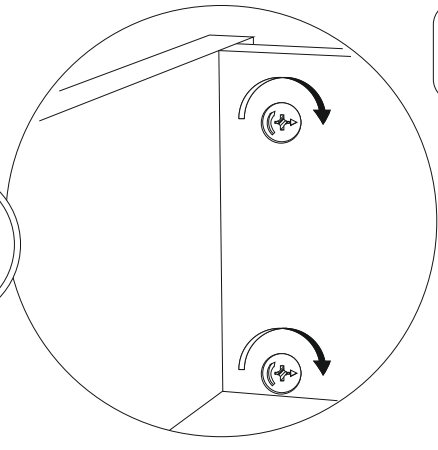
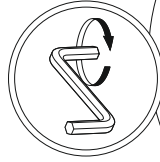
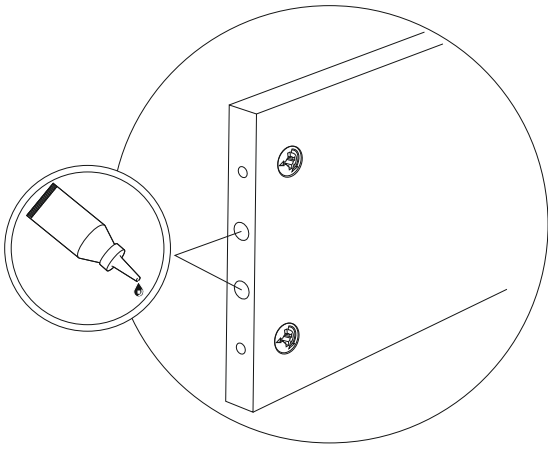

Woohoo!

High-fives all around for a job well done.

We hope your little one is over the moon with their new Petit Puk bed. And why not show off all your hard work? Snap a pic and share it with us on Instagram (tag us @petitpuk) or shoot us an email at info@petitpuk.com. We love seeing our creations come to life in your wonderful homes!

Now, before your kid dives in headfirst, here are a few friendly reminders:

- Stick to mattresses between 8-14 cm thick for the perfect fit.
- Beds are for snoozing, not bouncing
- Keep it safe with just one child on the bunk bed.
- Please, no acrobatics - avoid hanging off any parts of the bed.
- Keep things tidy with a gentle wipe-down of wooden and plastic parts using a dry cloth and mild cleaner.

Warranty

We've got your back with a 2-year warranty on bed parts under normal use. If you ever need a hand or have any questions, don't hesitate to reach out to Team Petit Puk. Just send us a message with your name and order number, along with images of the situation.