





## Assembly Manual for CATO

Congratulations on your new Petit Puk bed! Get ready to transform your kid's sleeping space into a fortress of imagination, a castle of coziness, and a launchpad for their sweetest dreams! When you follow this step-by-step assembly, you'll breeze through the process.

Quick Checklist:

-  Is everything complete?
-  All pieces in good shape?
-  Do no start adding glue before you made sure all pieces are there and in perfect shape
-  Note! Applying glue to the bed base is **not** mandatory, as it could hinder the disassembly process later on. Let's keep things flexible for future adventures!
-  Ready to take a photo of your great work once completed and share with us?

Ticked all the boxes? Put on your superhero cape, and let's dive into the wonderful world of bed building.

Big wave,  
Team Petit Puk

**Questions?** Reach out via [customercare@petitpuk.com](mailto:customercare@petitpuk.com)

**Compliments?** Tag us on instagram @petitpuk

# Table of contents

- CATO / entry on the side p. 3 - 25
- CATO / entry in the middle p. 26 - 48

CATO: entry on the side

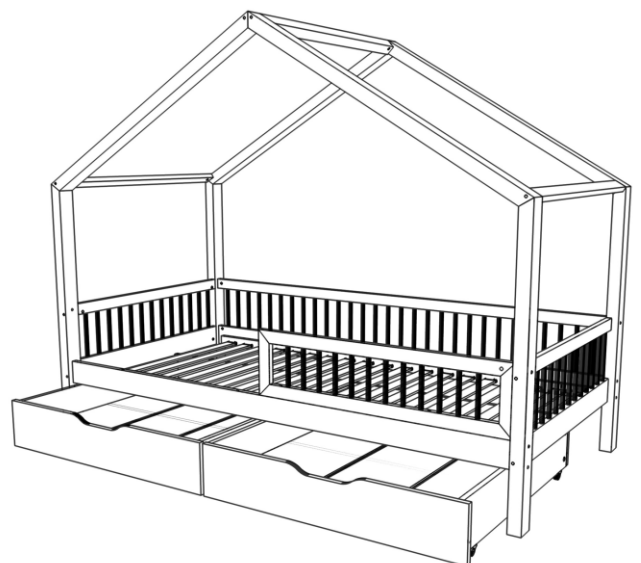
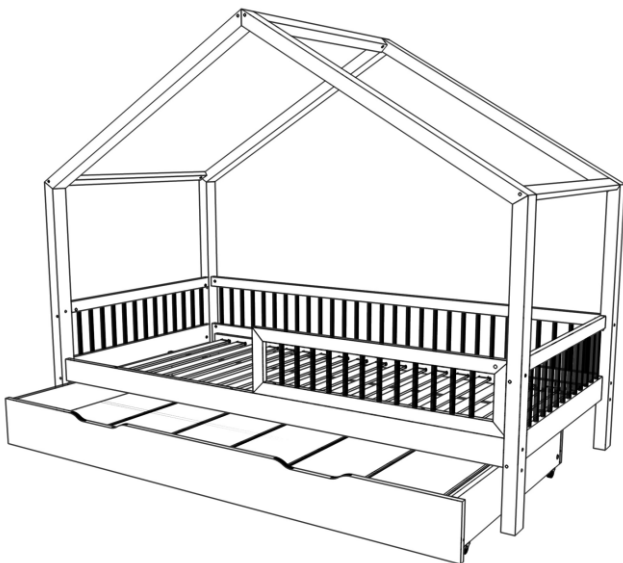
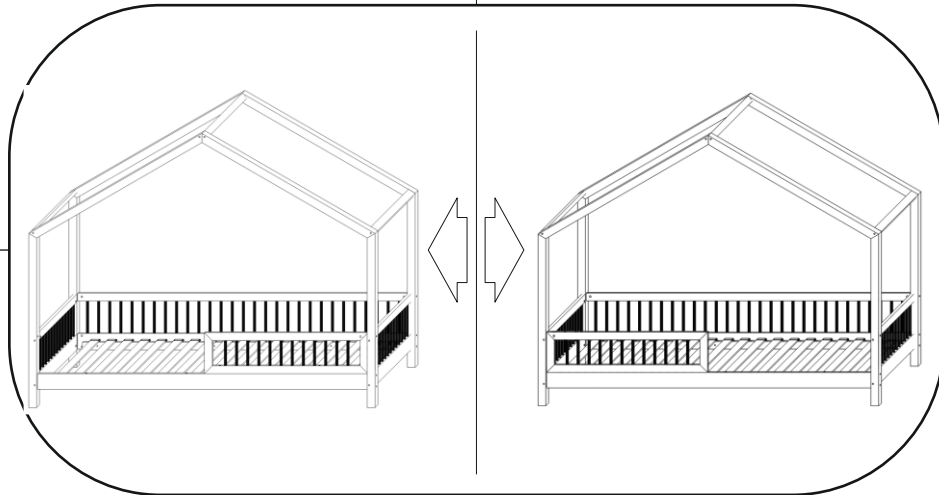
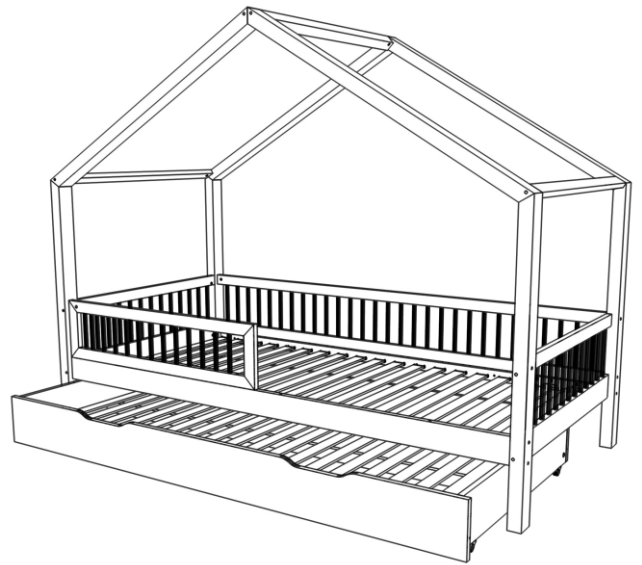
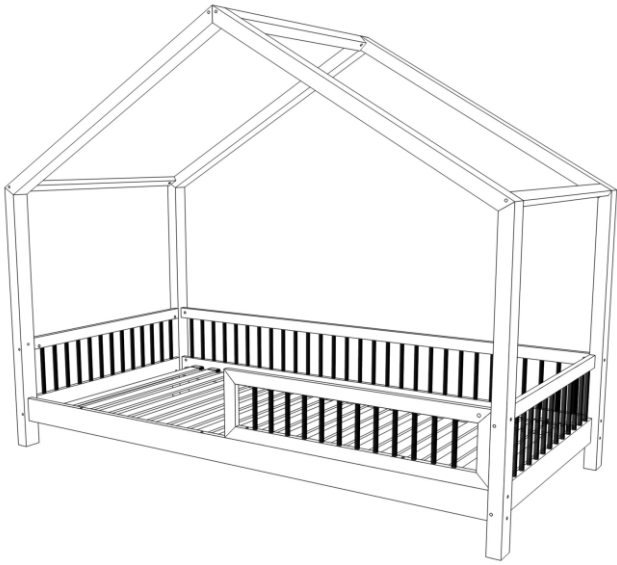



## **IMPORTANT! KEEP FOR FUTURE REFERENCE: READ CAREFULLY.**

- a. Warning: Be aware of the risks posed by open fire and other heat sources such as electric or gas heaters etc. near the bed.
- b. Warning: Do not use the bed if any part is damaged, torn or missing, use only the parts approved by the manufacturer.
- c. Warning: Do not leave anything in the bed or place the bed near any other equipment that could support the foot or pose a risk of suffocation or hanging the child, such as cords, curtain / blind cords.
- d. Warning: Do not use more than one mattress in the bed.
- e. Recommended maximum mattress thickness of 12 cm - 15 cm.
- f. The selected bed size is the size of the mattress to be used.
- g. It is recommended that all assembly elements be tightened well during assembly, regularly checked and tightened if necessary.

**Warning:** Before starting the assembly, please check all the elements. If any parts are damaged, please do not assemble the bed, and notify us of the damaged parts immediately by email, with photos, so that we can send you replacement parts. Once the bed has been assembled, any complaint regarding damages parts will no longer be accepted.



**WICHTIG! FÜR SPÄTERES NACHSCHLAGEN AUFBEWAHREN:  
SORGFÄLTIG LESEN.**

- a. **Warnung:** Seien Sie sich der Risiken bewusst, die durch offenes Feuer und andere Wärmequellen wie Elektro- oder Gasheizungen usw. in der Nähe des Bettes entstehen.
- b. **Warnung:** Verwenden Sie das Bett nicht, wenn Teile beschädigt, gerissen oder fehlen, verwenden Sie nur die vom Hersteller zugelassenen Teile.
- c. **Warnung:** Lassen Sie nichts im Bett liegen und stellen Sie das Bett nicht in die Nähe anderer Geräte, die den Fuß stützen oder eine Erstickungsgefahr oder das Aufhängen des Kindes darstellen könnten, wie z.B. Drähte, Gardinen-/Rolloschnüre.
- d. **Warnung:** Verwenden Sie nicht mehr als eine Matratze im Bett.
- e. **Empfohlene maximale Matratzendicke von 12 cm - 15 cm.**
- f. **Die gewählte Bettgröße ist die Größe der zu verwendenden Matratze.**
- g. **Es wird empfohlen, alle Montageelemente während der Montage gut anzuziehen, regelmäßig zu kontrollieren und ggf. nachzuziehen.**

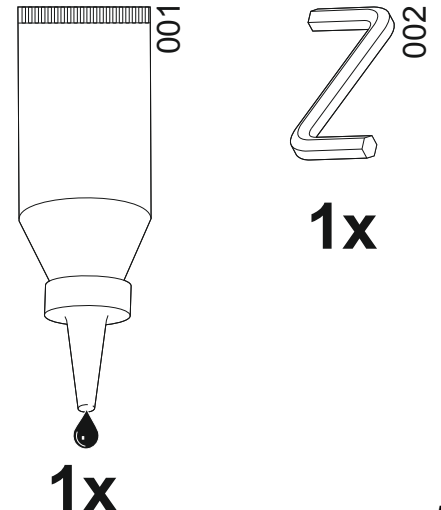
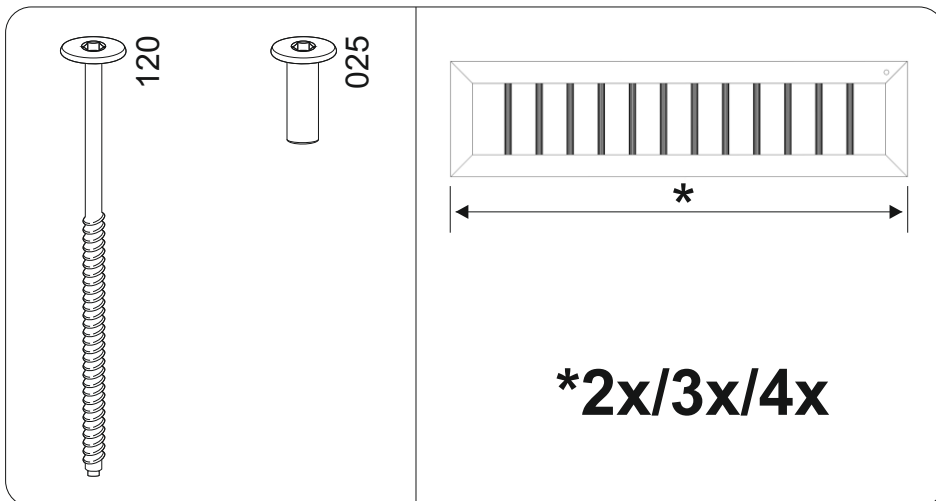
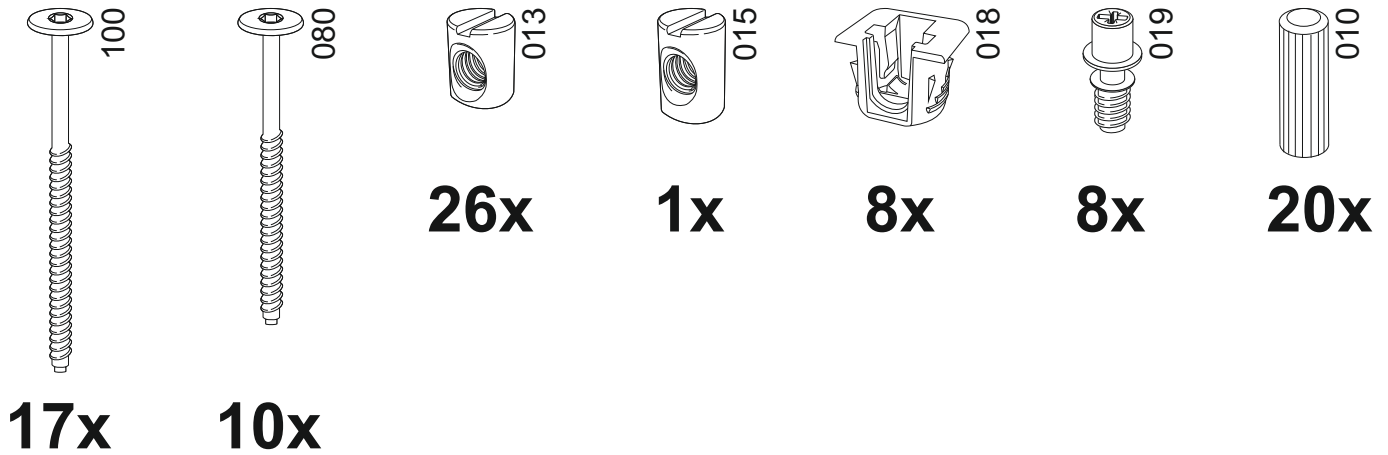
**Achtung:** Bitte prüfen Sie vor dem Aufbau ob Sie alle Elemente erhalten haben. Sollten einige Teile beschädigt sein, bitten wir Sie das Bett vorerst nicht aufzubauen und uns die Schäden schriftlich zu melden. Wir werden diese schnellstens ersetzen. Sollte das Bett bereits aufgebaut worden sein, so kann die Reklamation nicht akzeptiert werden.

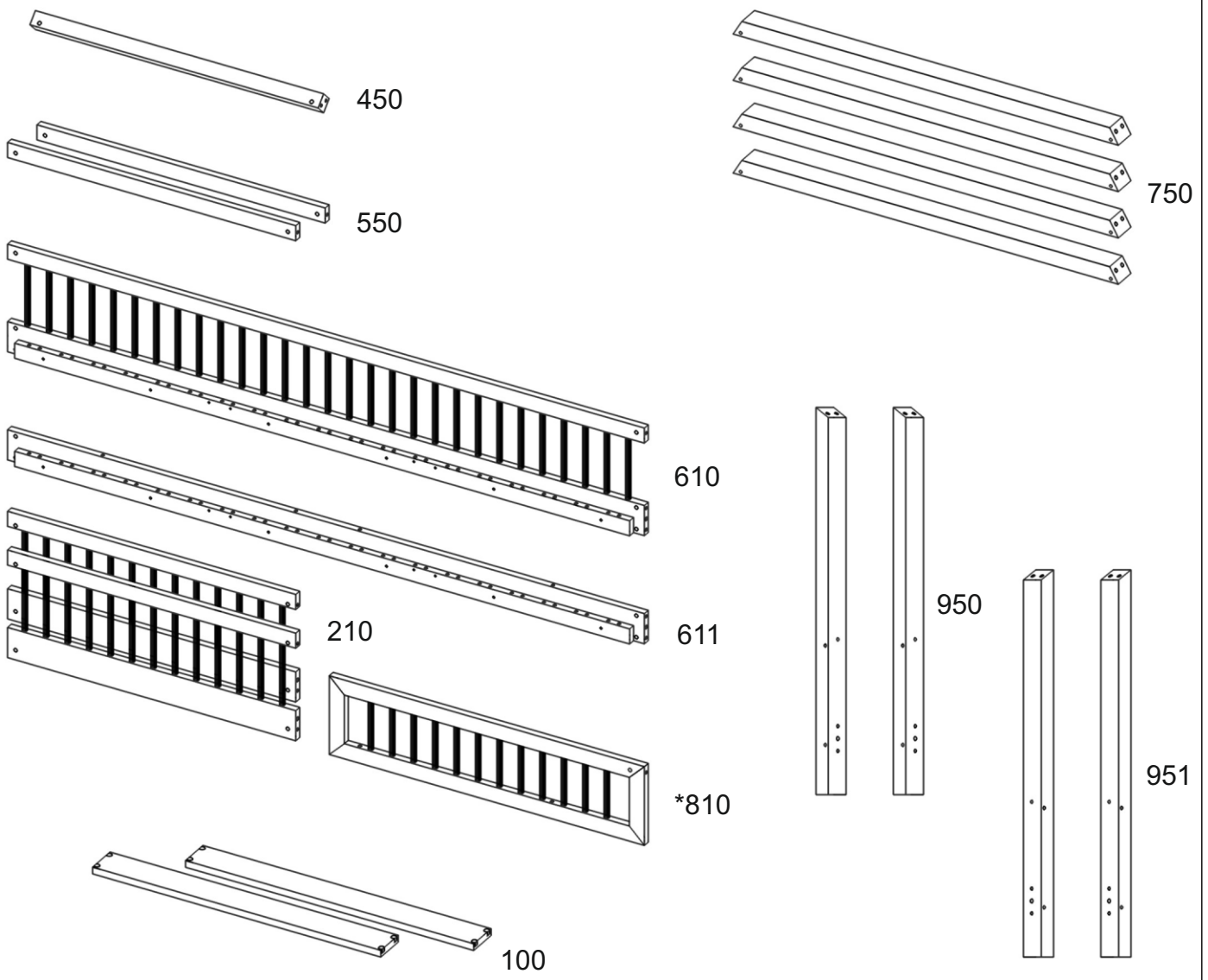

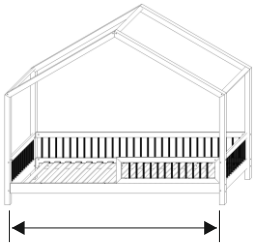
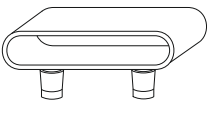
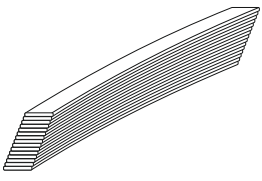
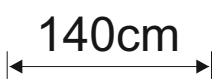
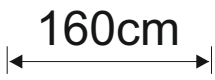
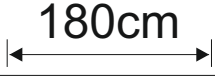

	 055	 090
 140cm	<b>28x</b>	<b>14x</b>
 160cm	<b>32x</b>	<b>16x</b>
 180cm	<b>34x</b>	<b>17x</b>
 190cm	<b>38x</b>	<b>19x</b>
 200cm	<b>40x</b>	<b>20x</b>

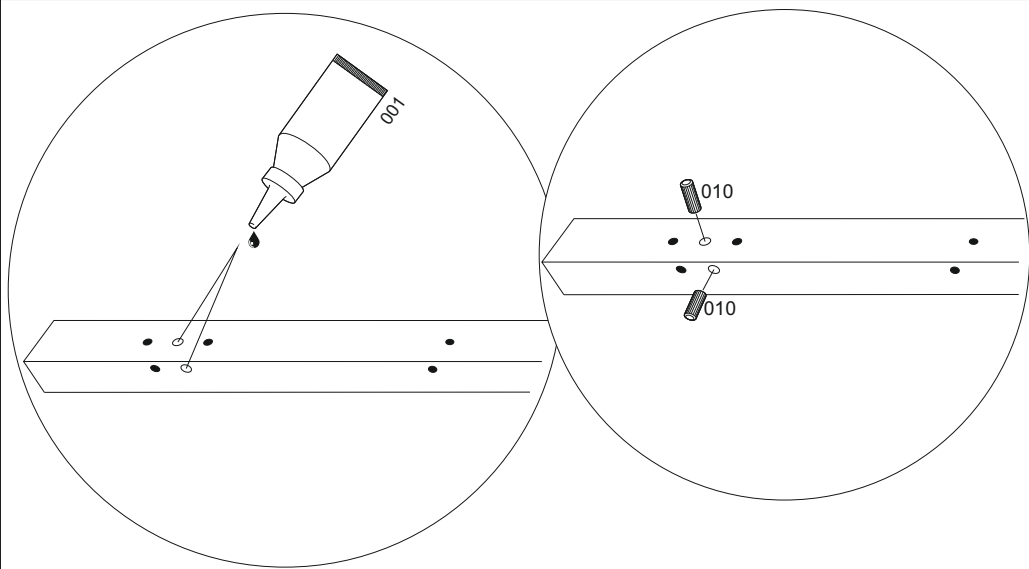

951

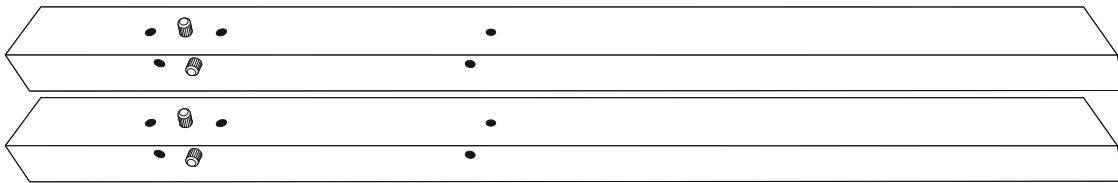

952

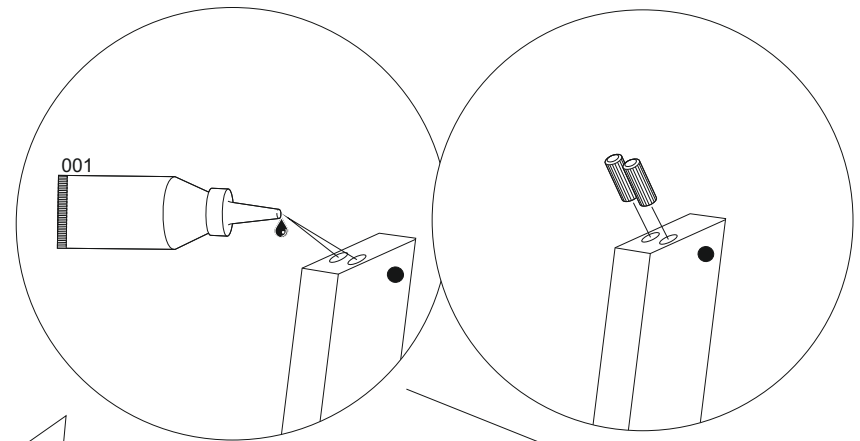
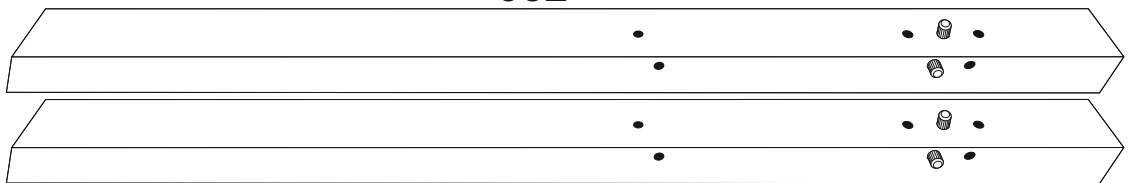

750

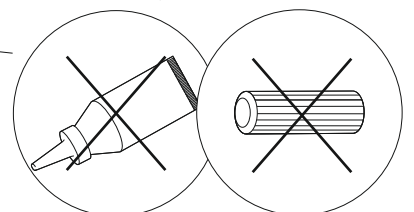
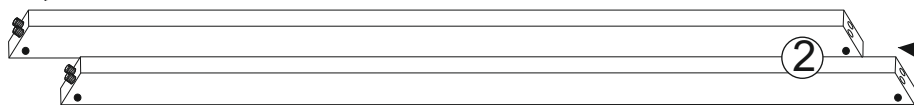
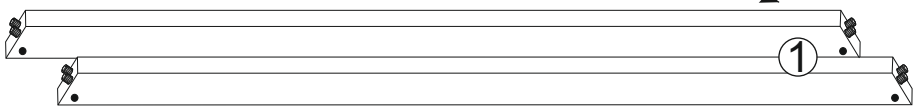

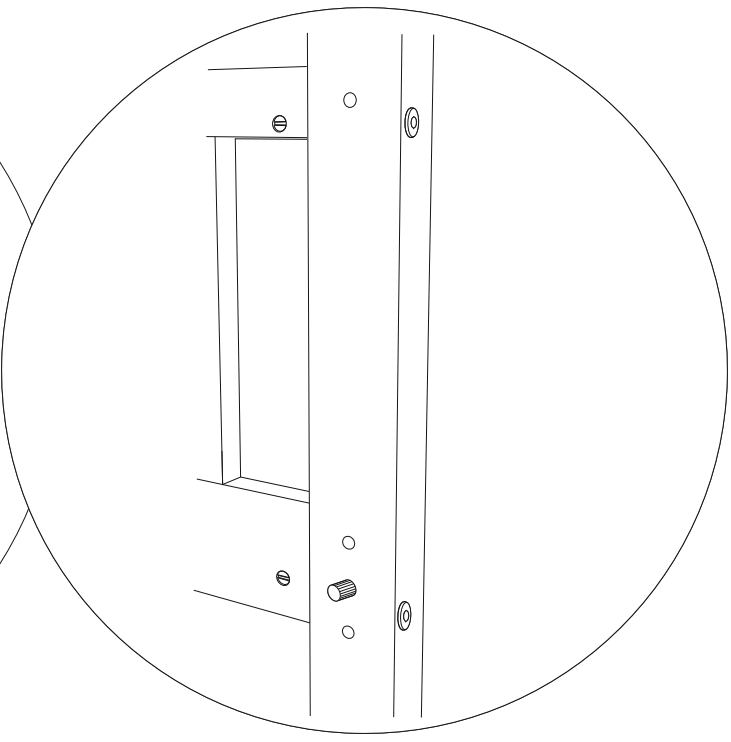
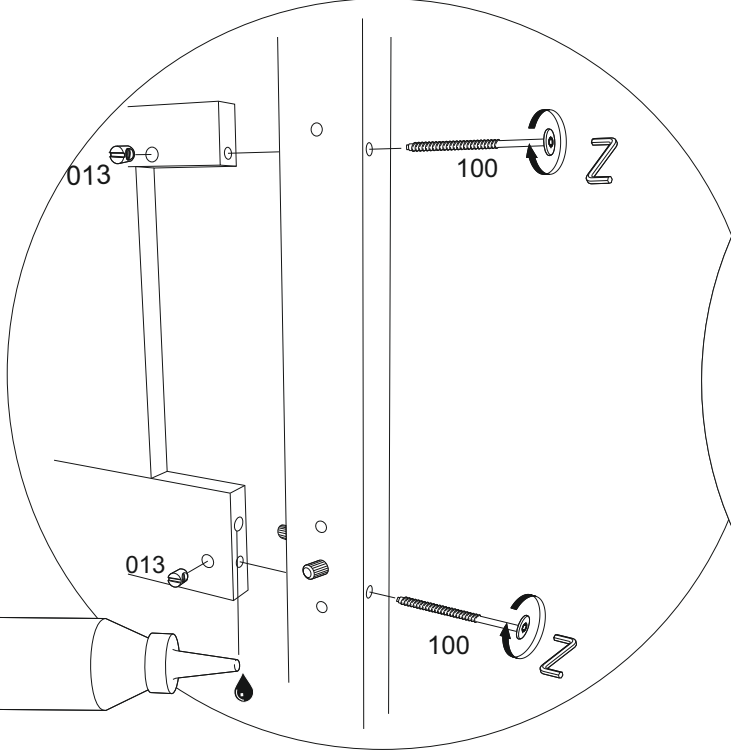
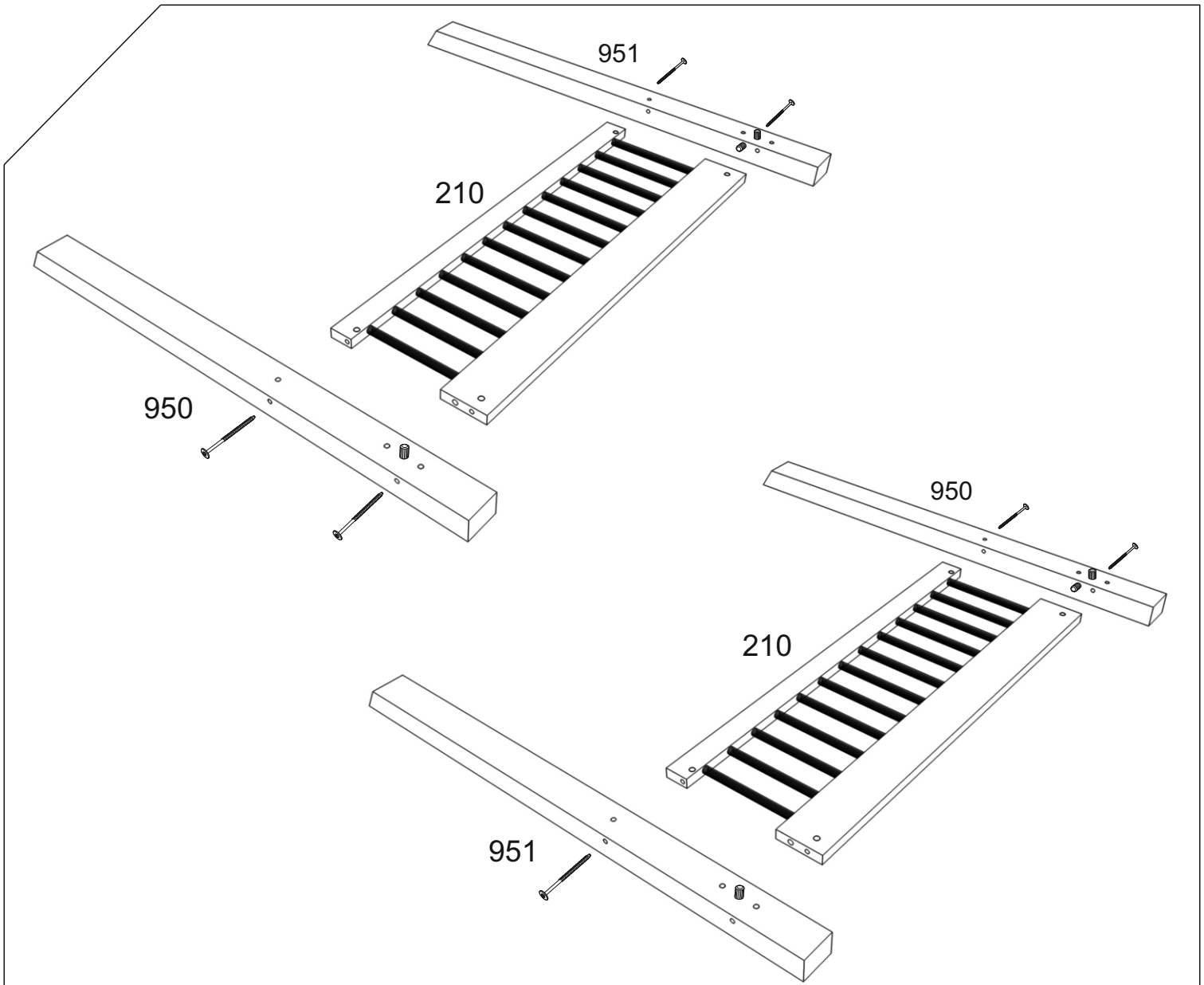



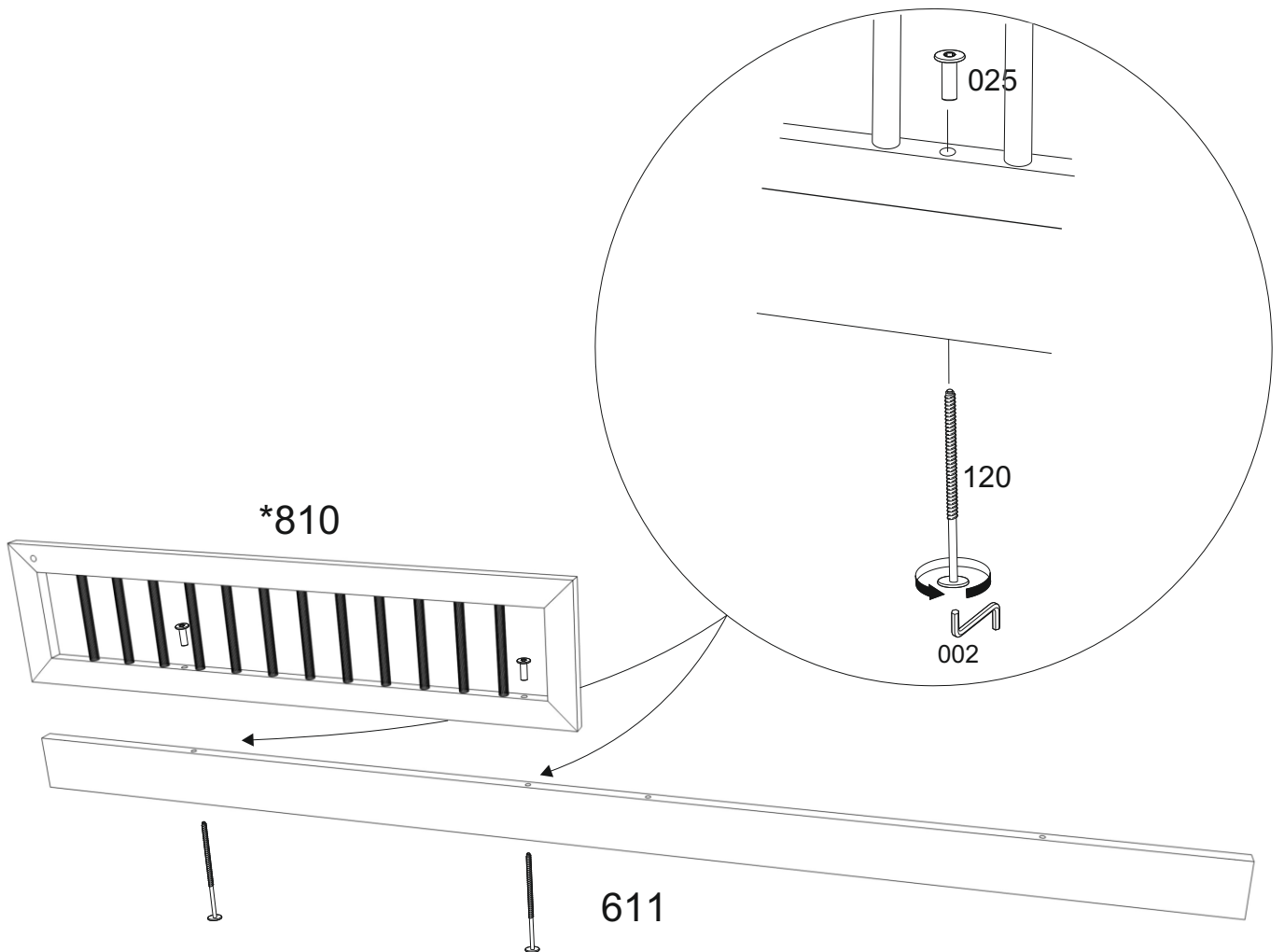
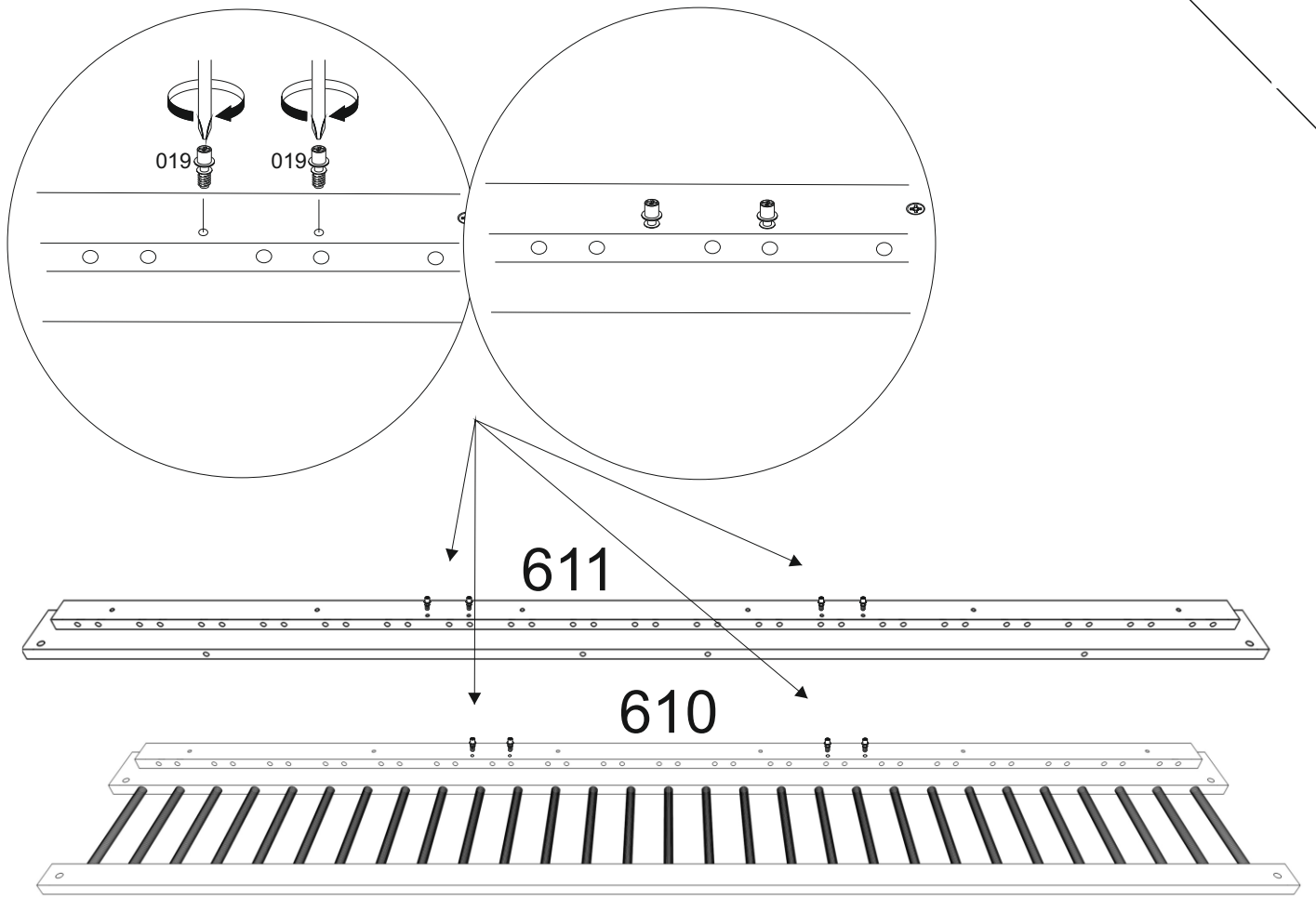

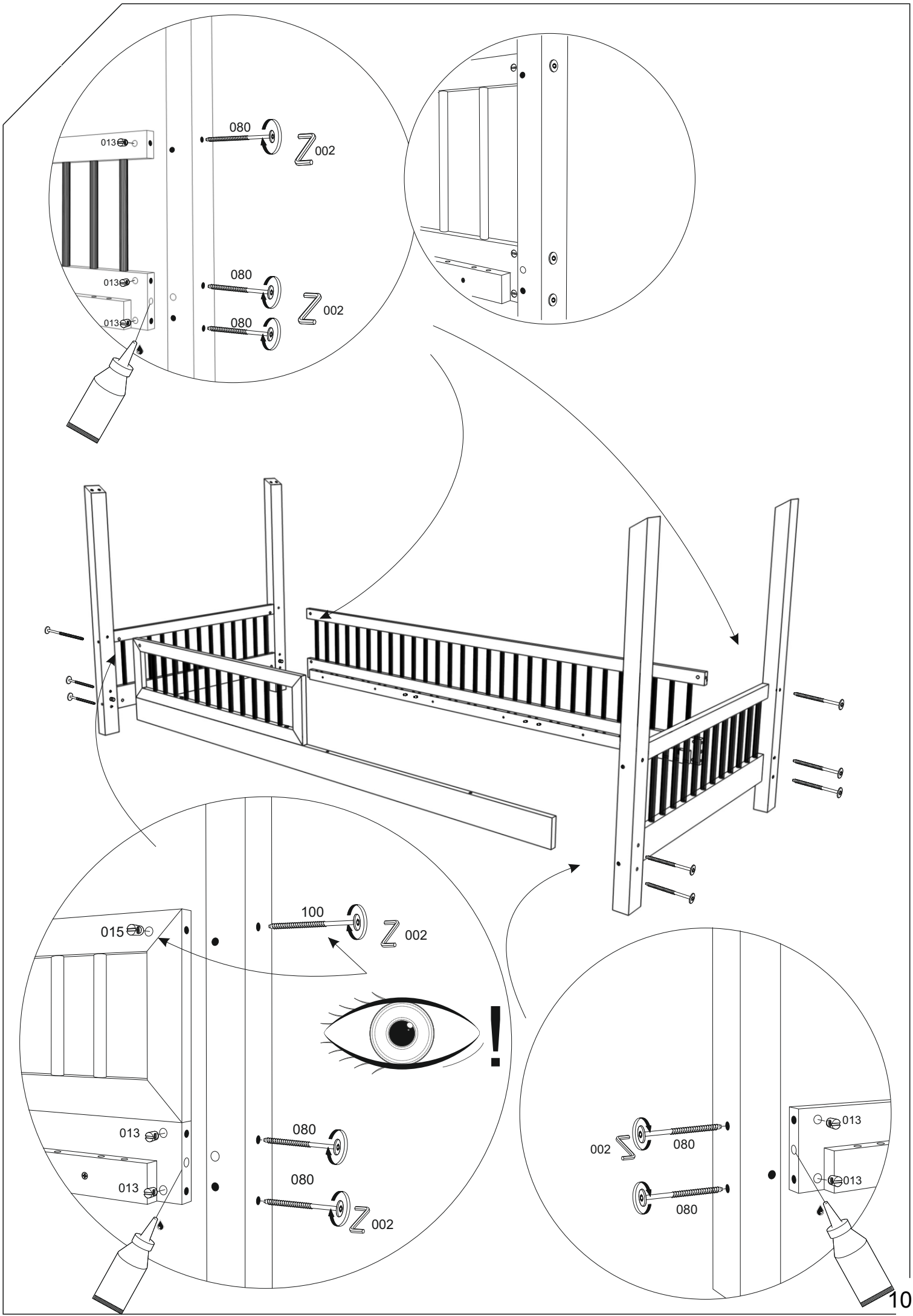

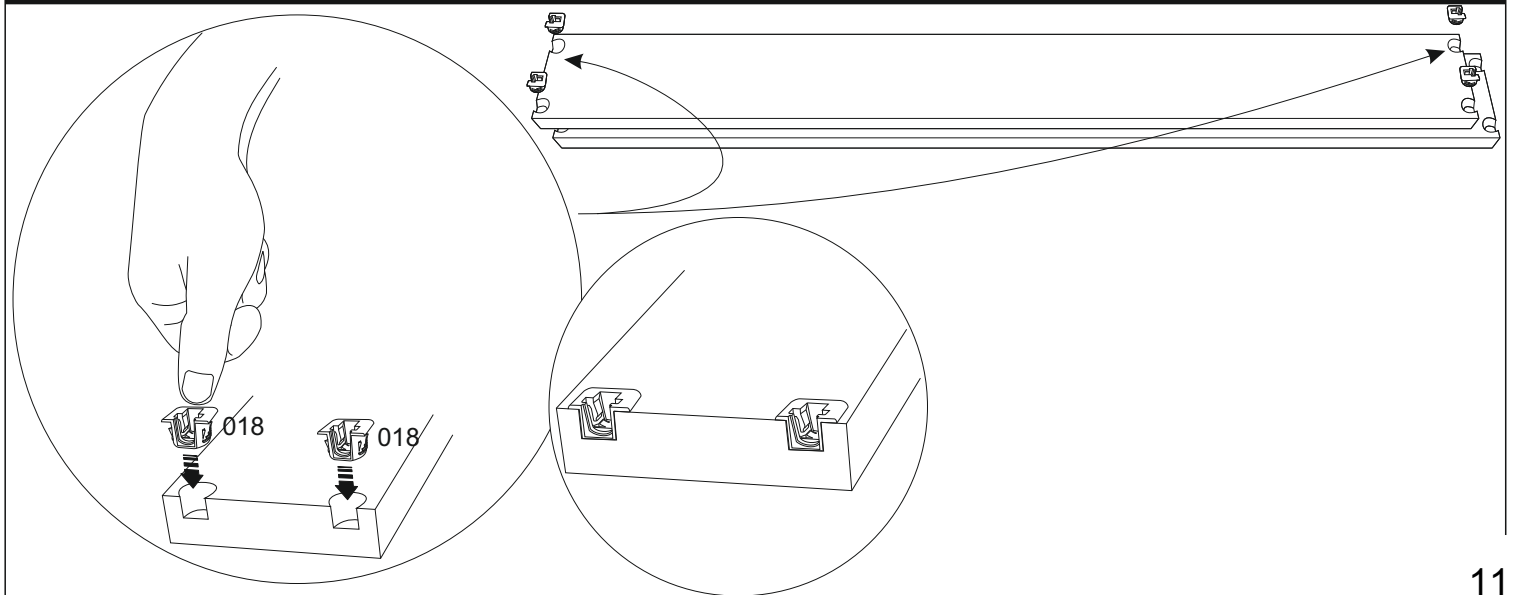
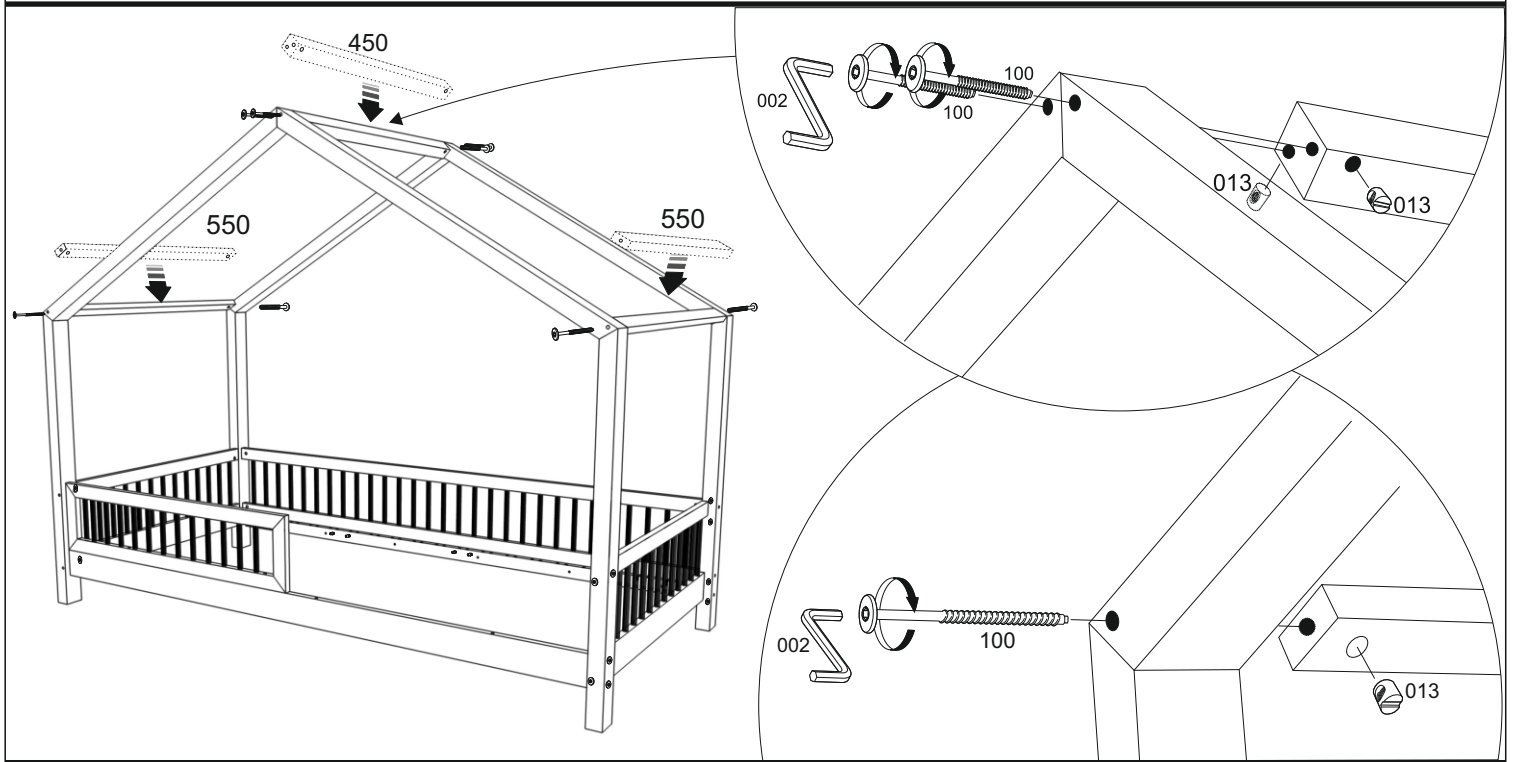
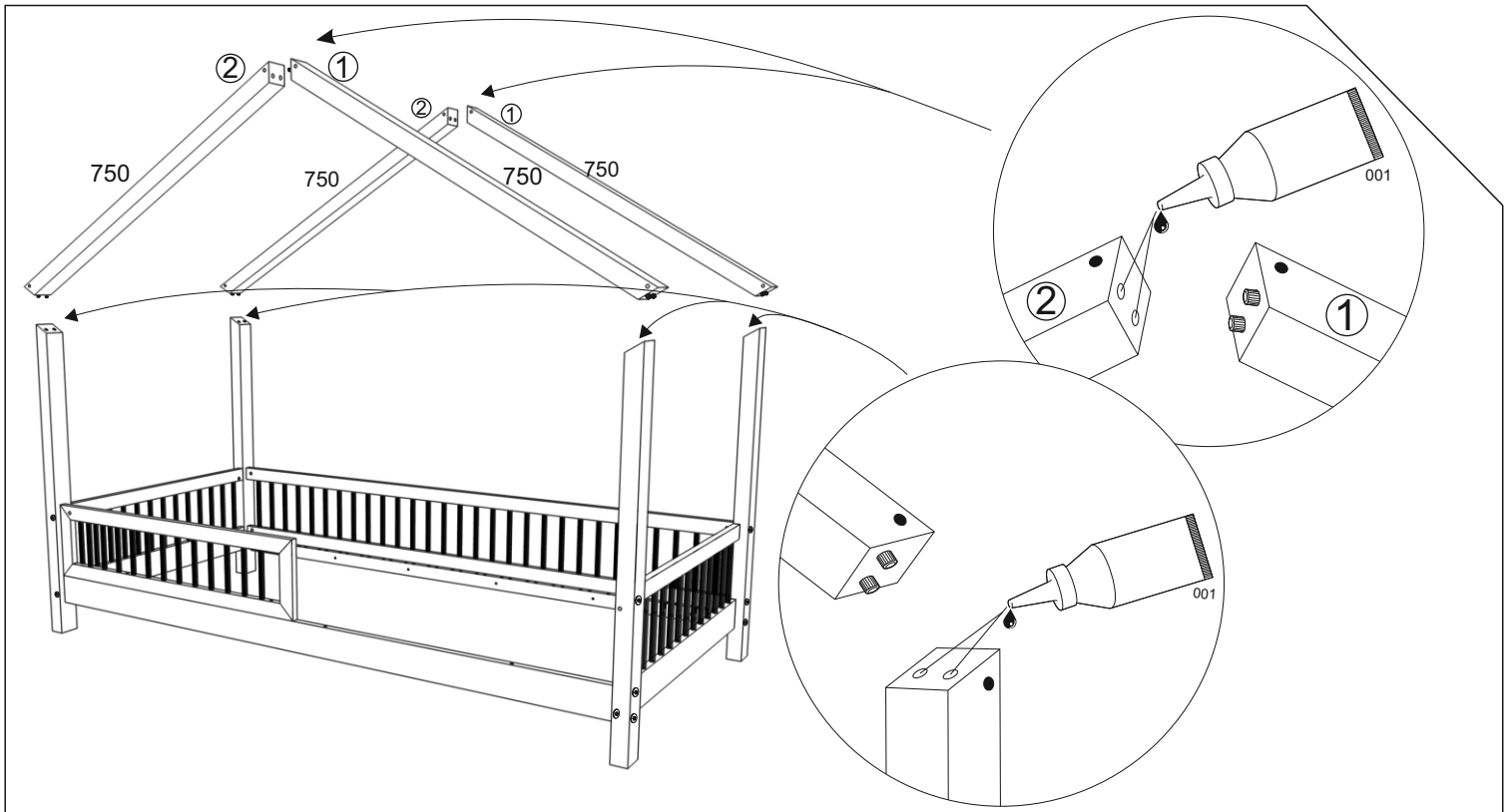

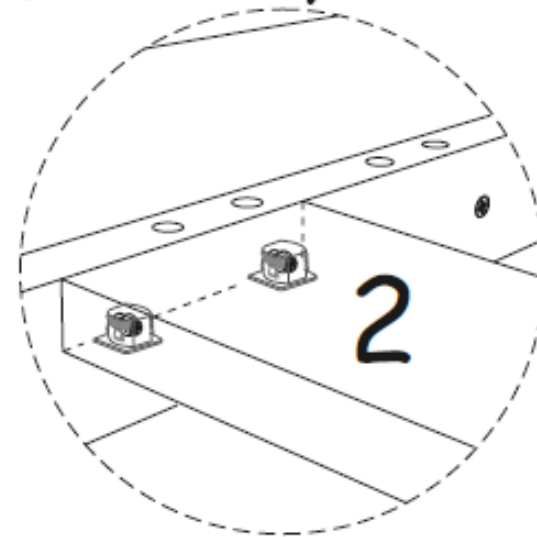
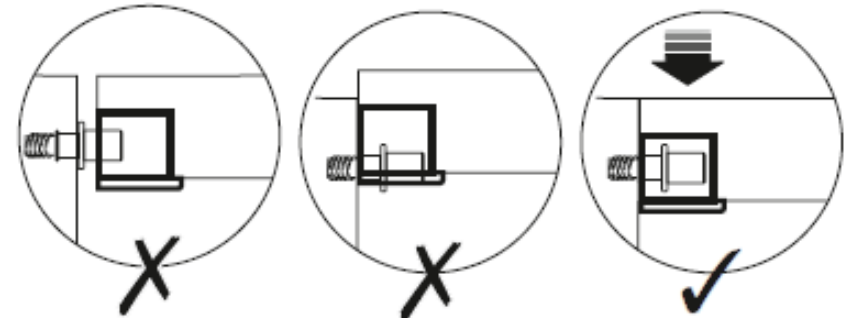
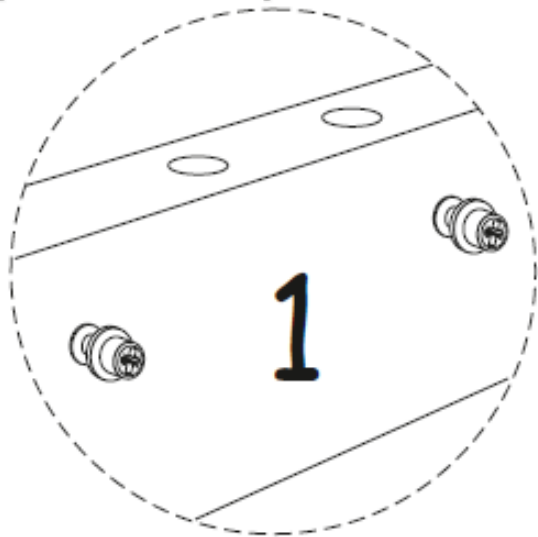
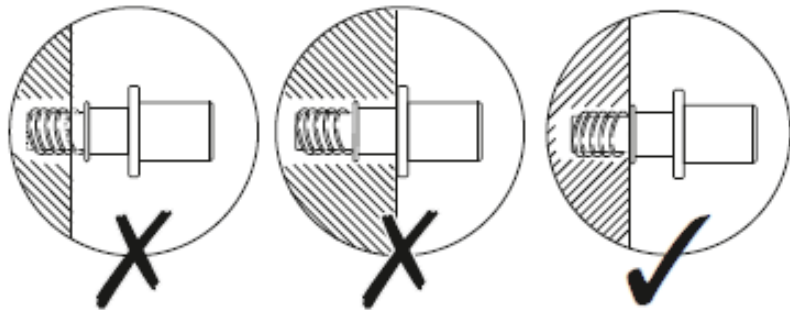
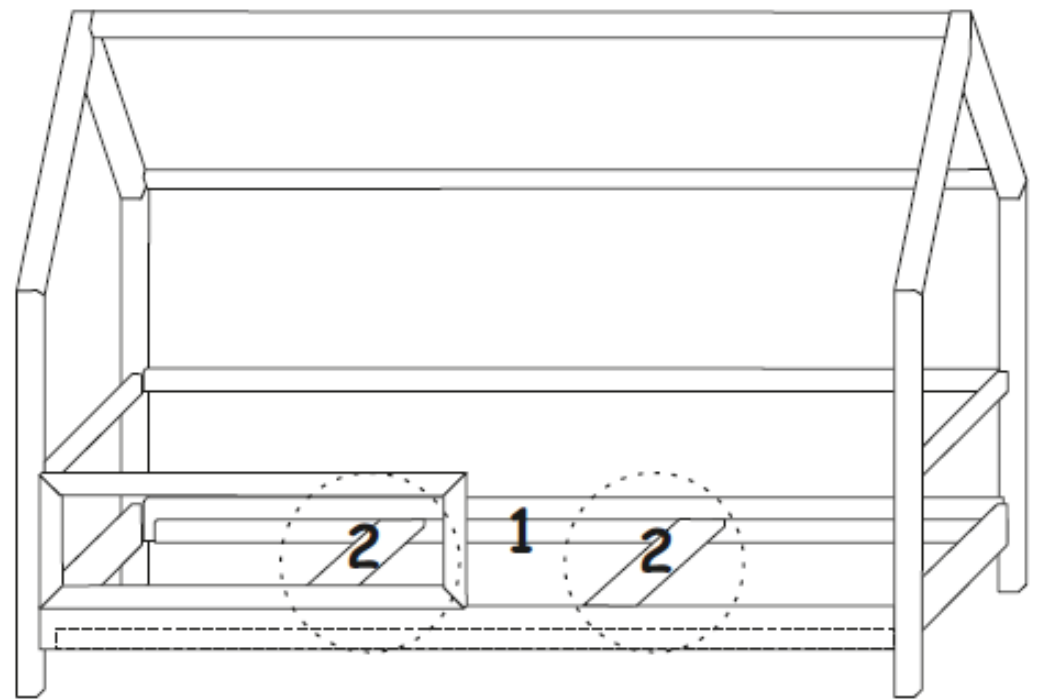

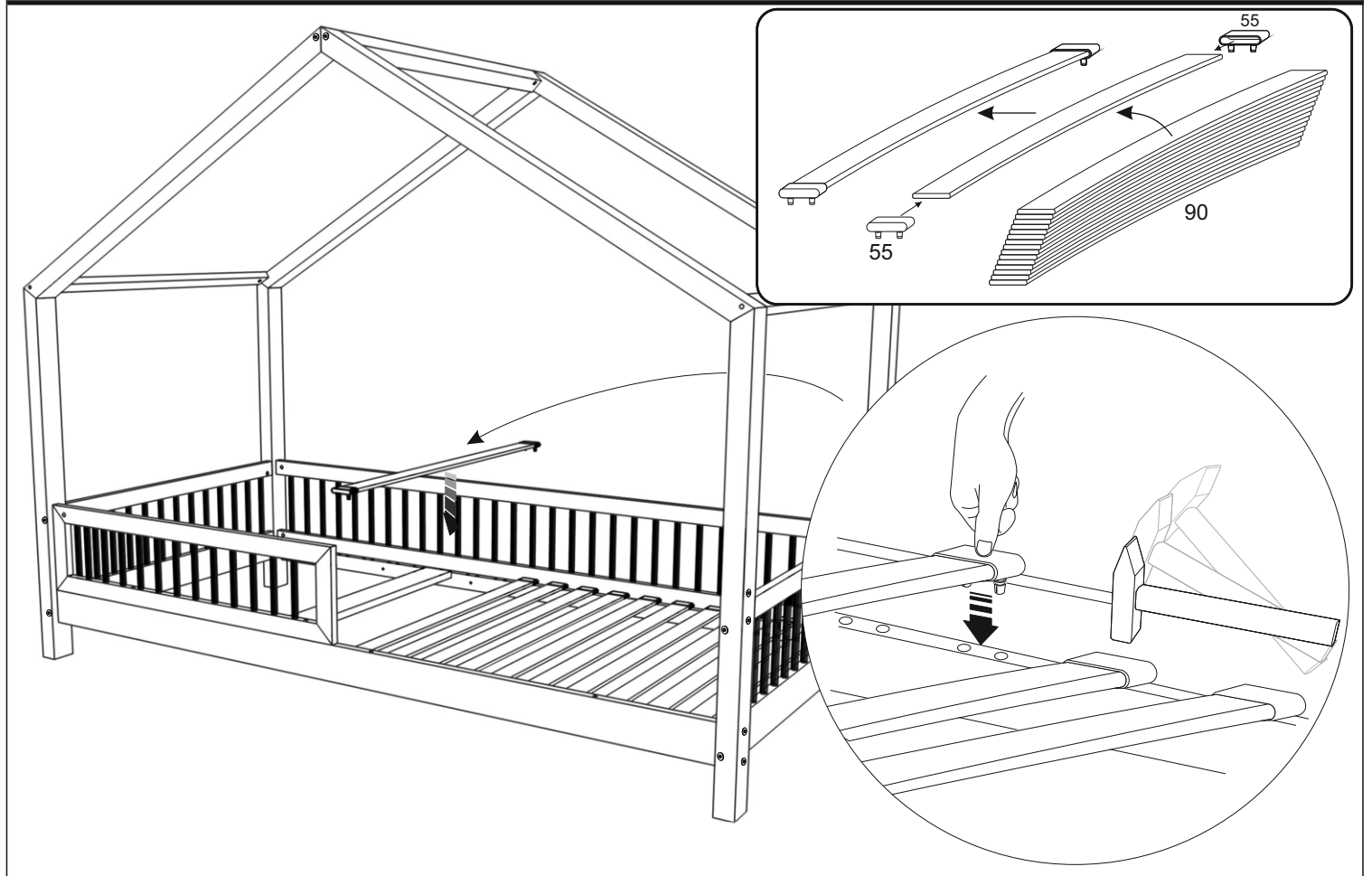
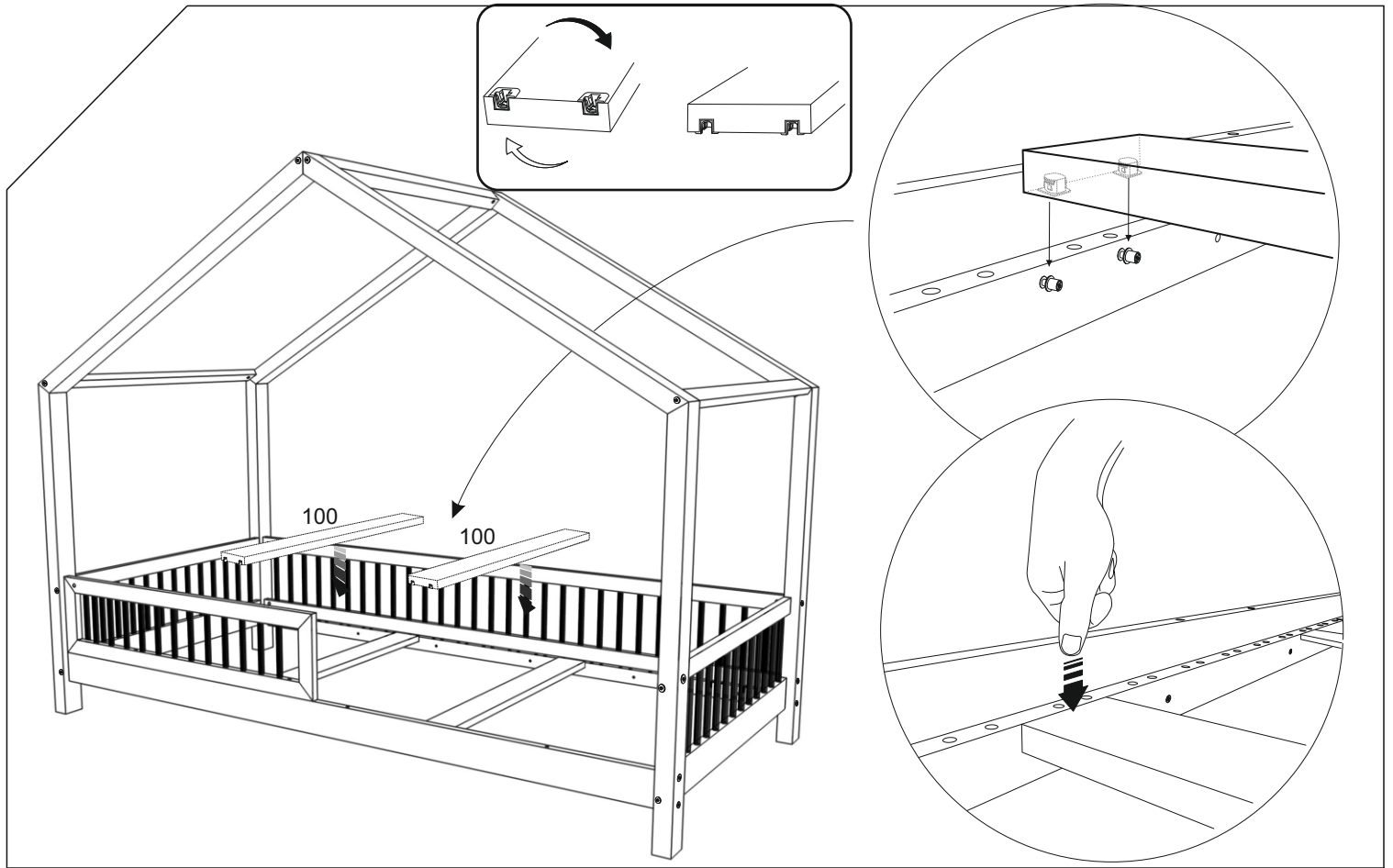

PLASTIC



METAL



PAPER

# Drawer assembly instructions

2-5

**A**

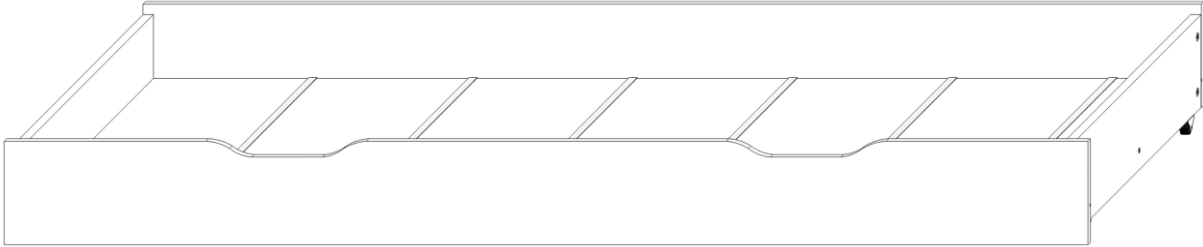

6-9



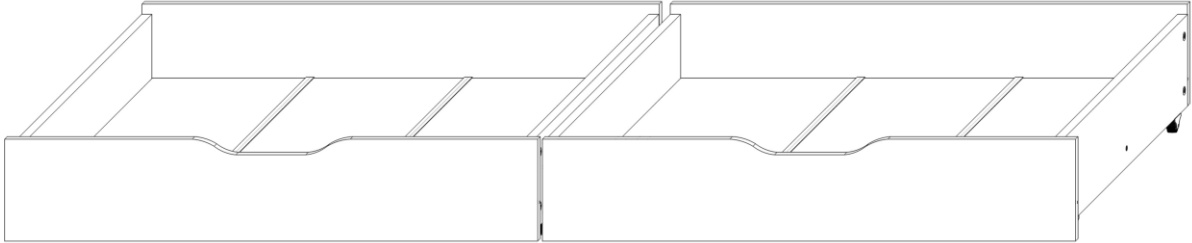



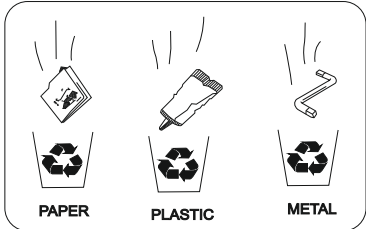
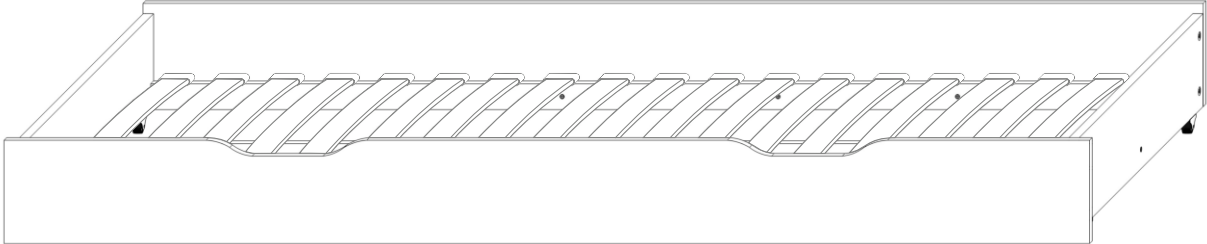

**B**

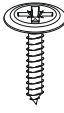
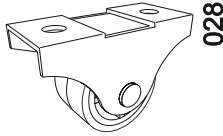

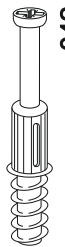
10-12

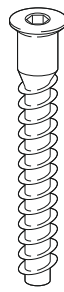
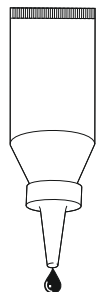
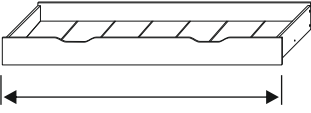
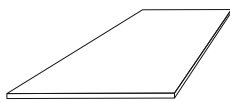
**C**

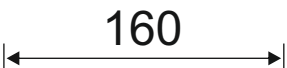
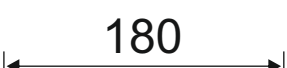

<b>A</b> <b>2</b>  <b>030</b> <b>8x</b>  <b>016</b> <b>8x</b>  <b>028</b> <b>4x</b>  <b>002</b> <b>1x</b>  <b>042</b> <b>8x</b>  <b>015</b> <b>8x</b>  <b>070</b> <b>2x</b>  <b>001</b> <b>1x</b>	 <b>152</b>  <b>153</b>		
	 <b>140</b>	<b>5x</b>	<b>4x</b>
	 <b>160</b>	<b>6x</b>	<b>5x</b>
	 <b>180</b>	<b>6x</b>	<b>5x</b>
	 <b>190</b>	<b>7x</b>	<b>6x</b>
	 <b>200</b>	<b>7x</b>	<b>6x</b>

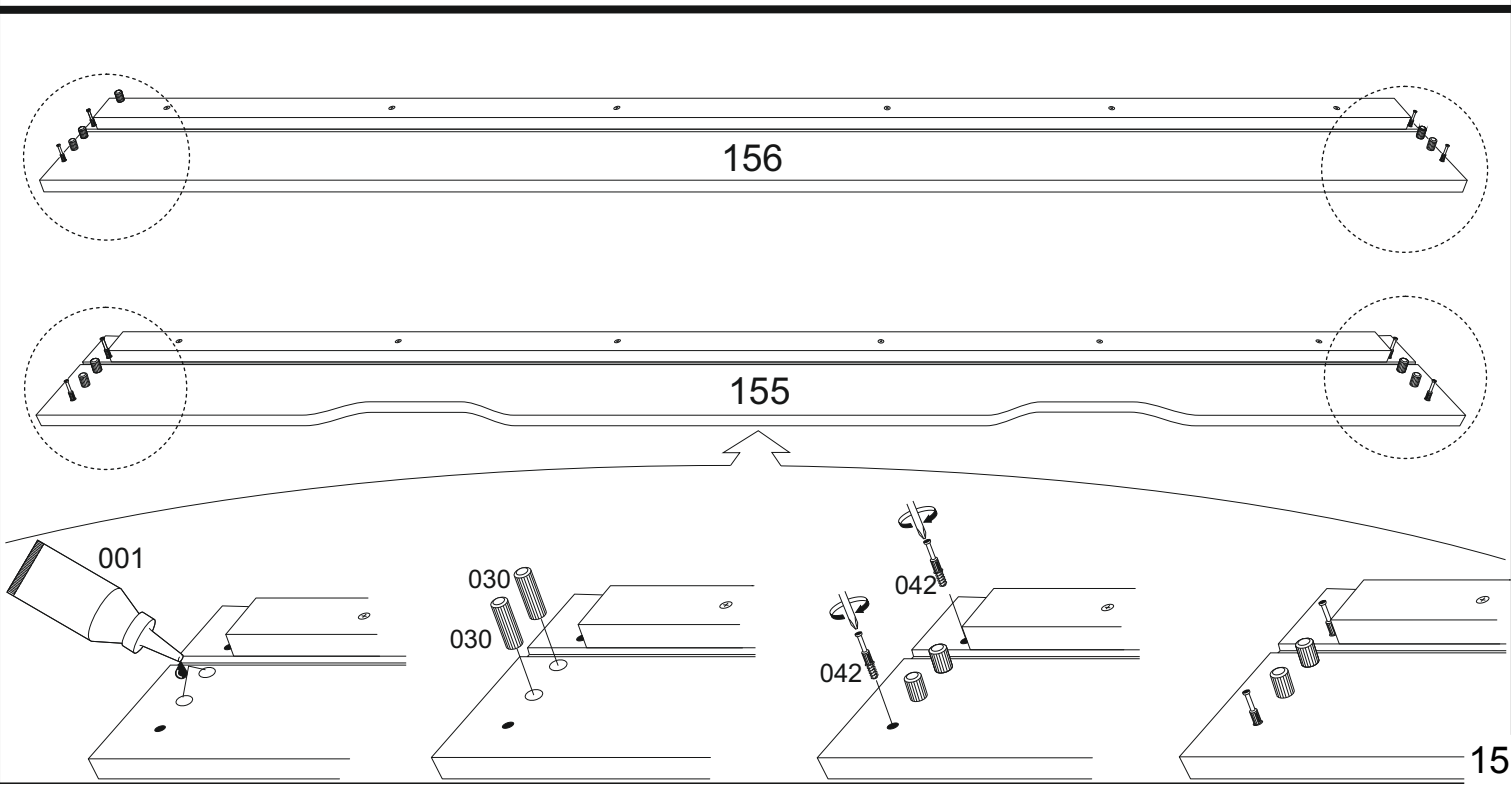
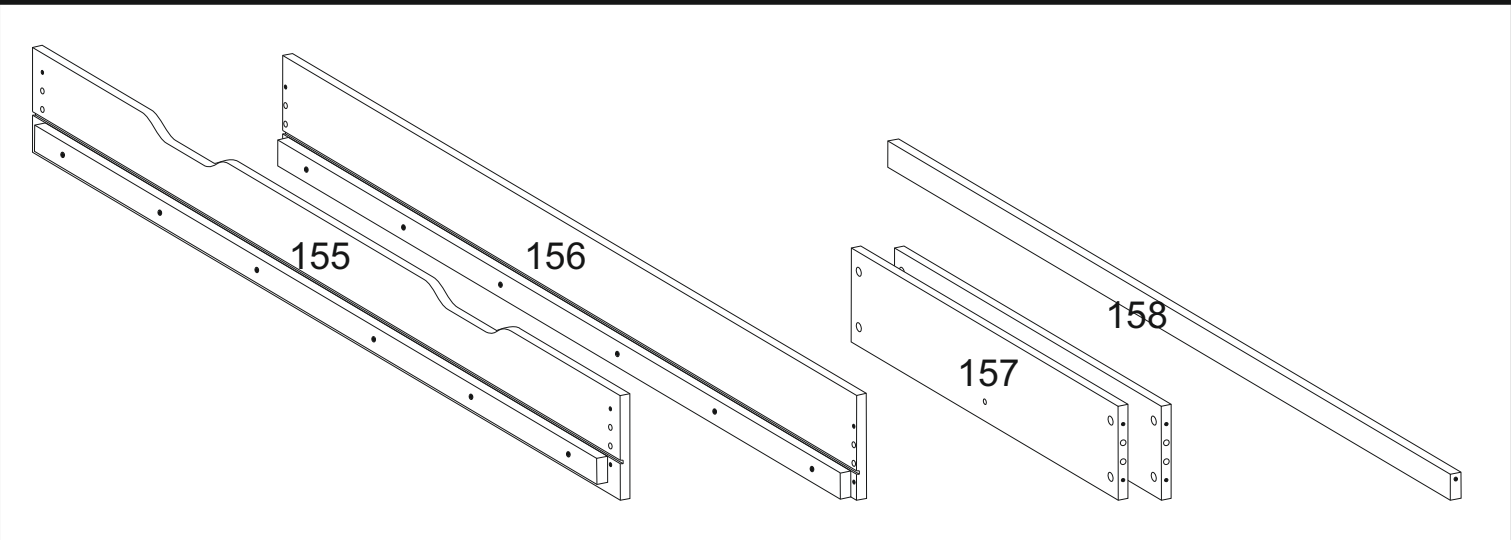

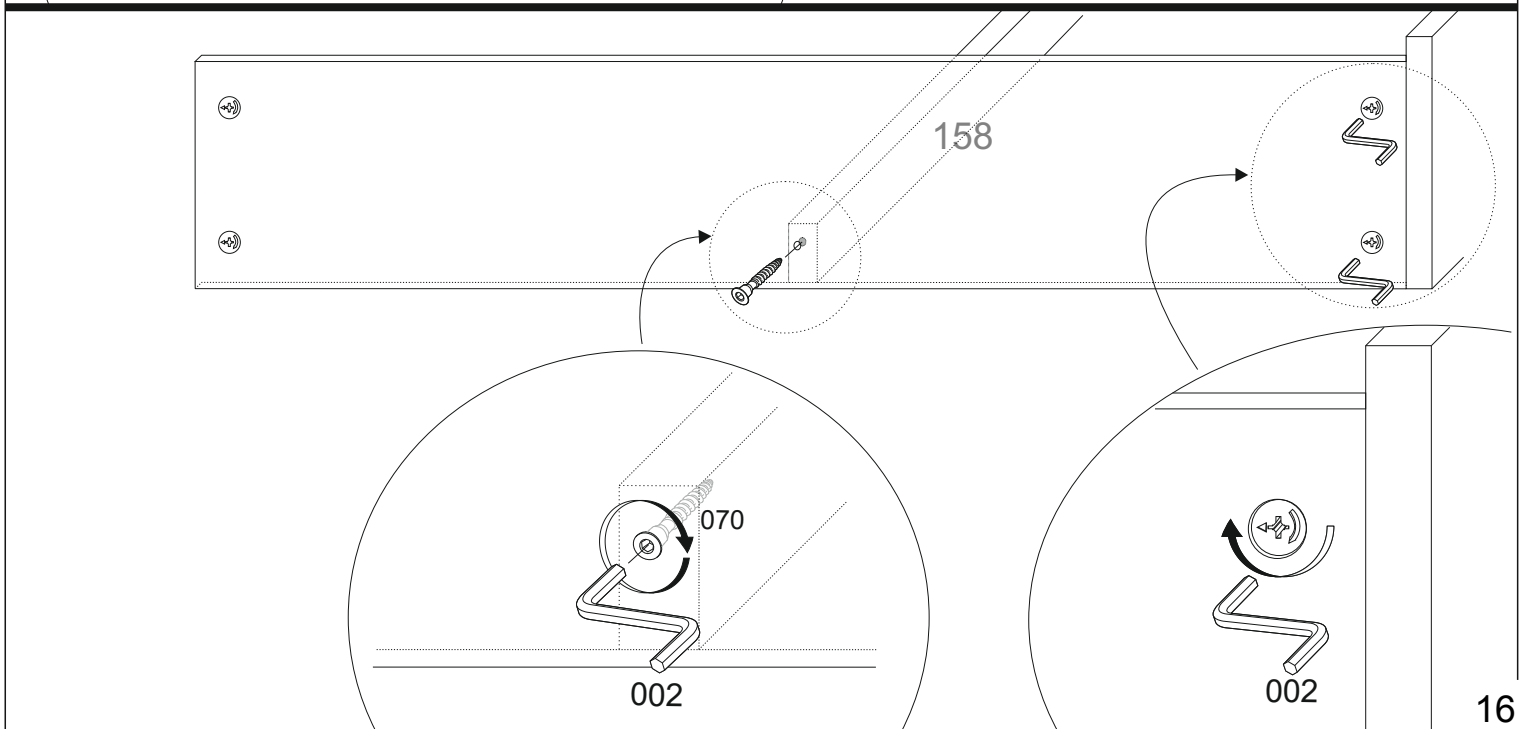
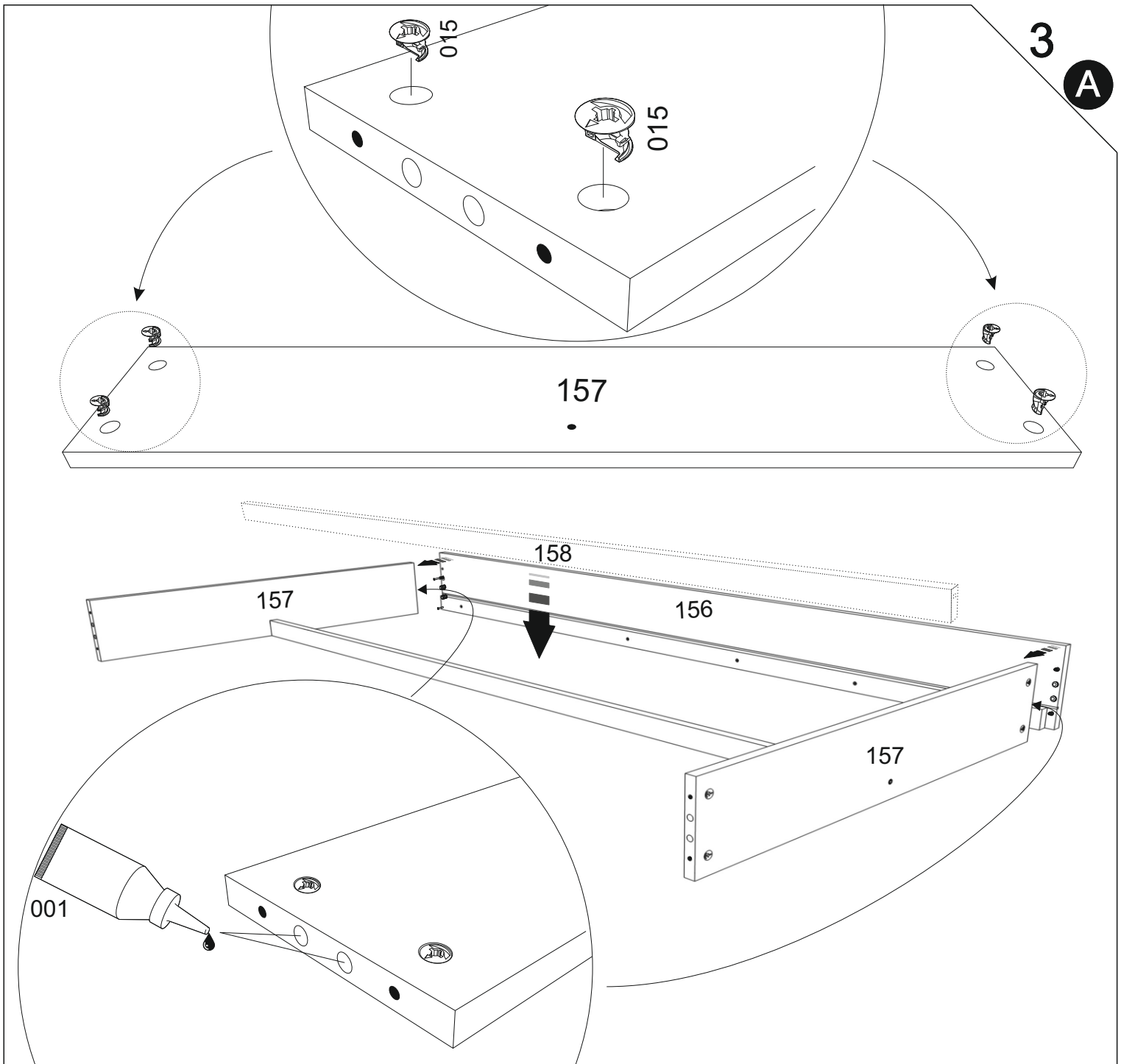



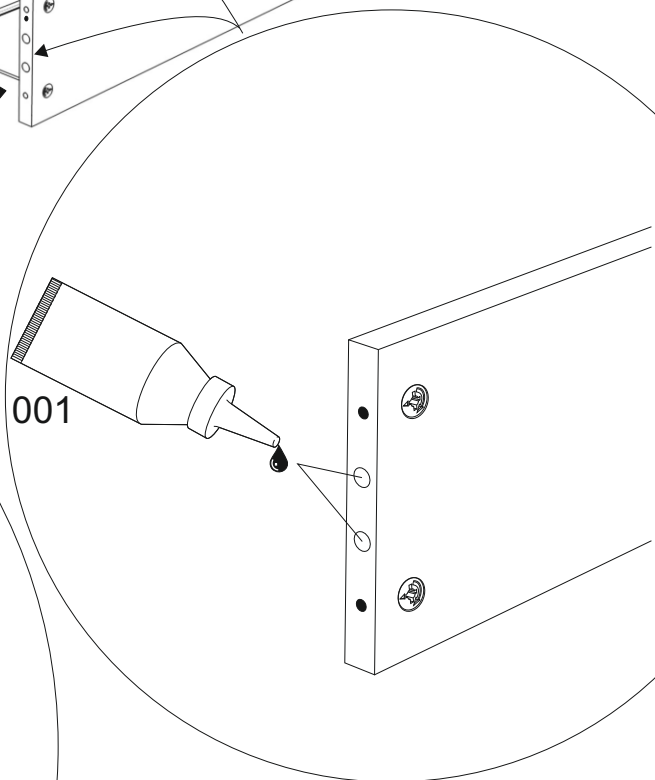
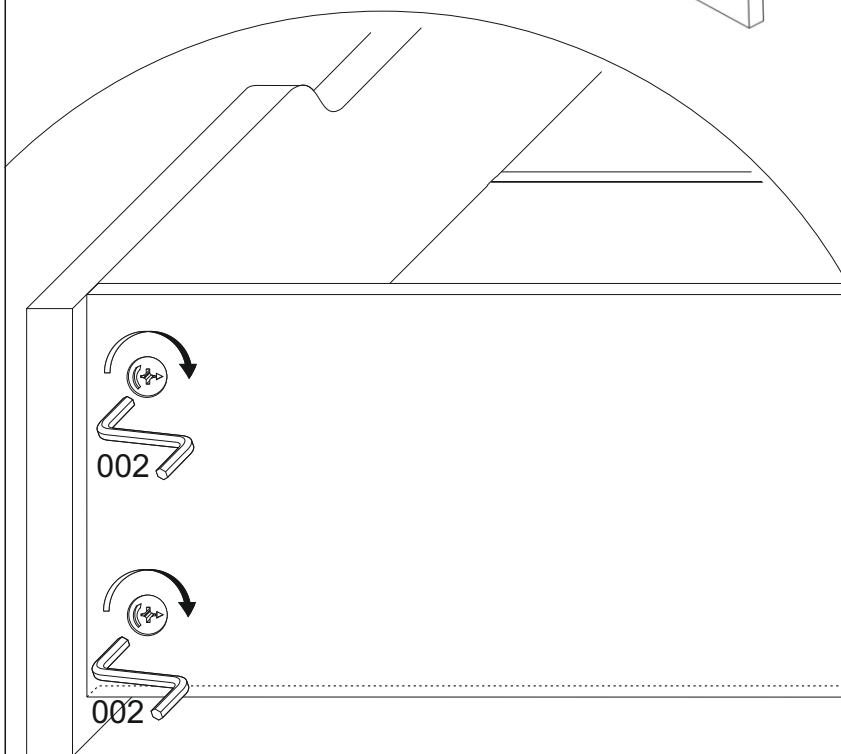
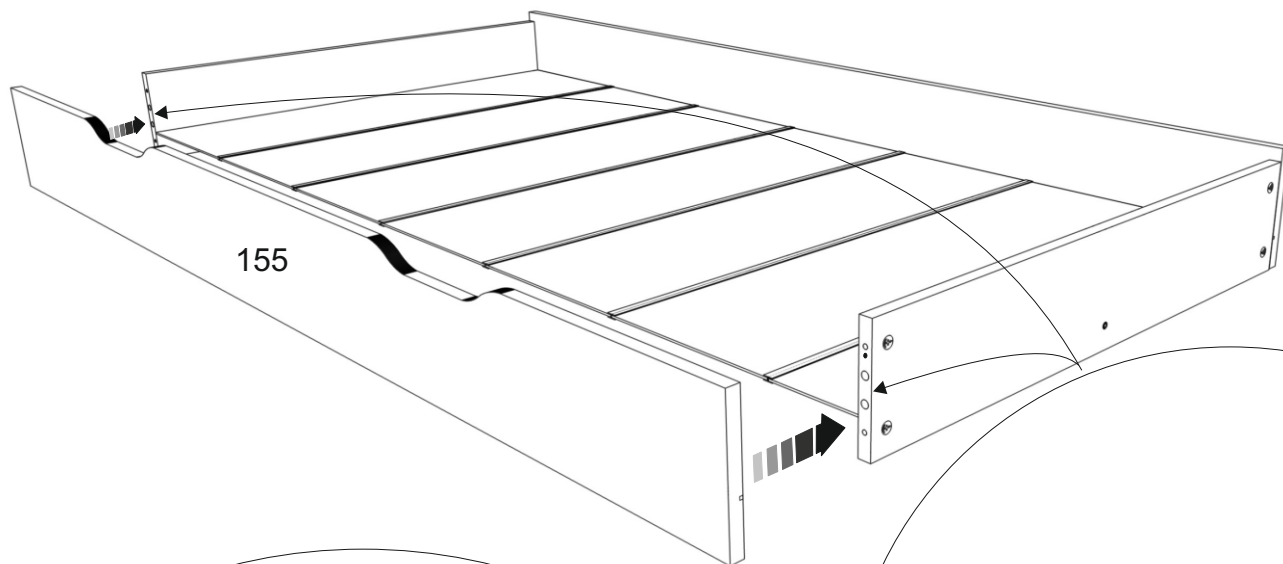
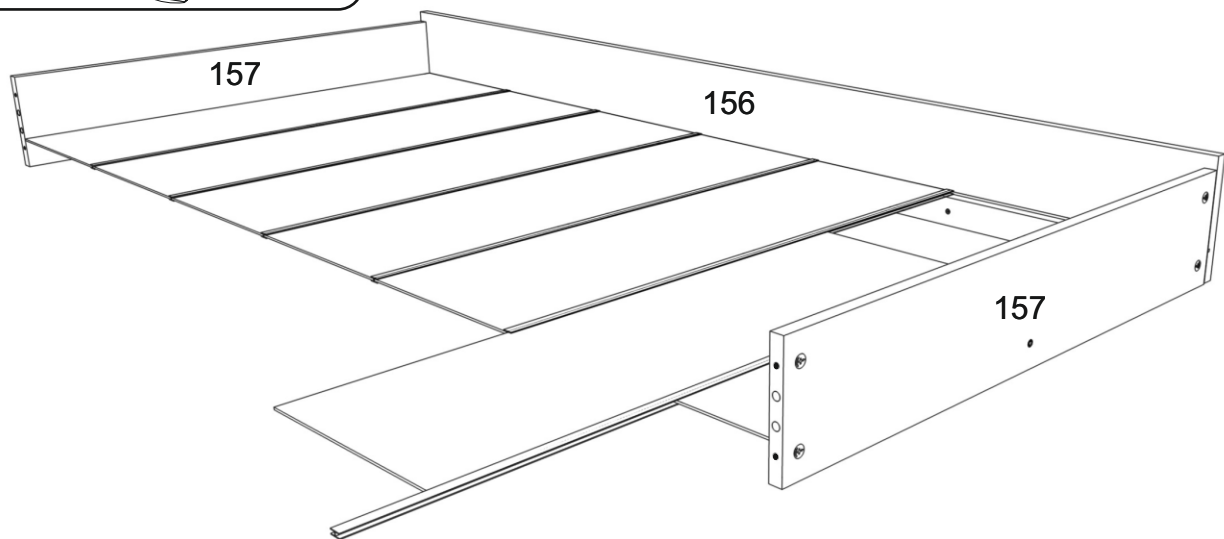
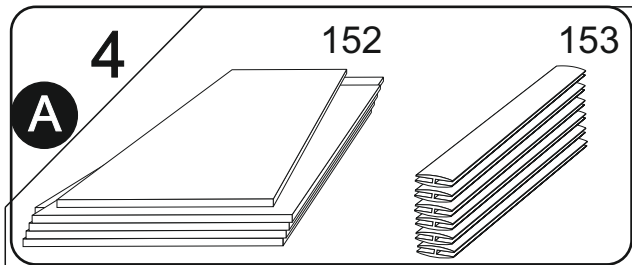

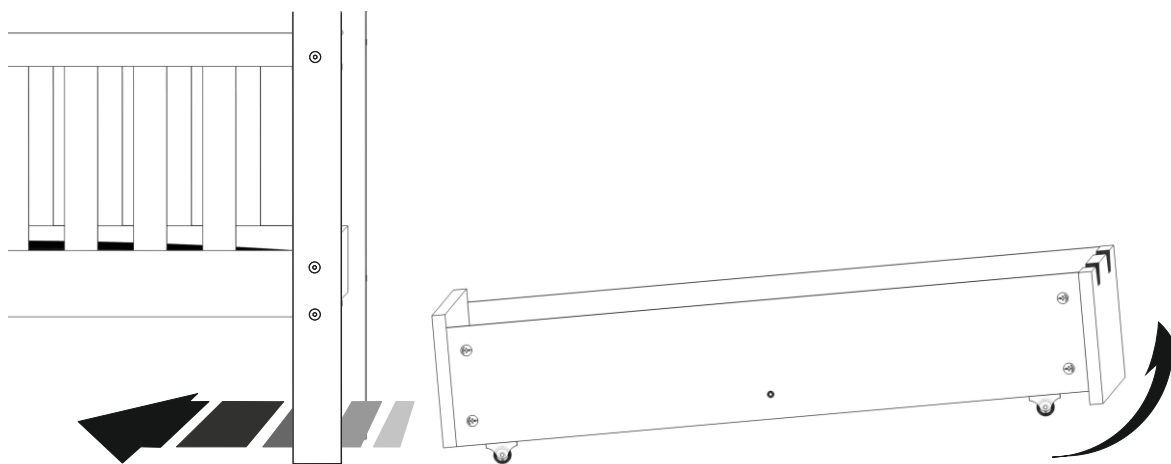
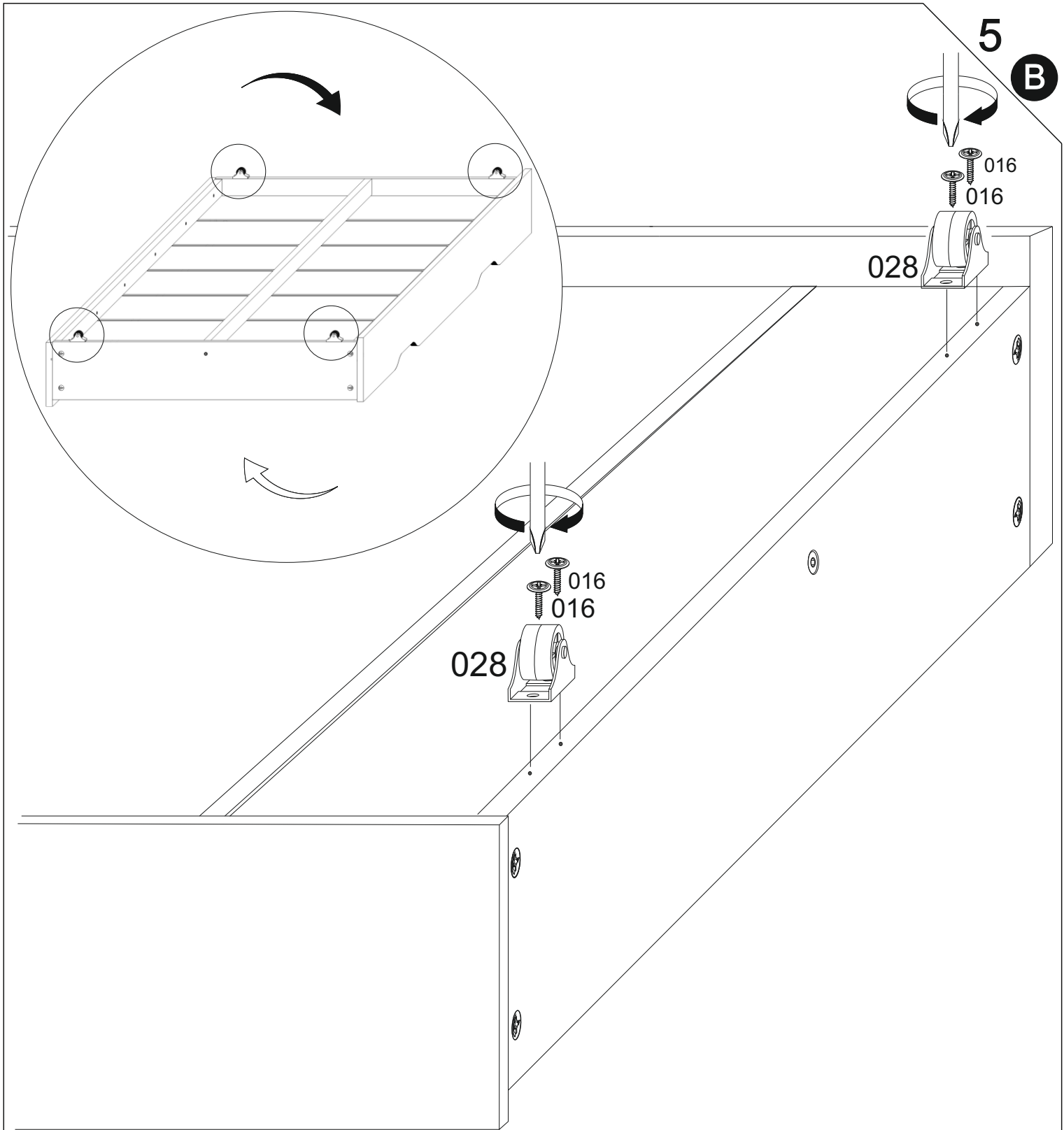

**B** 6

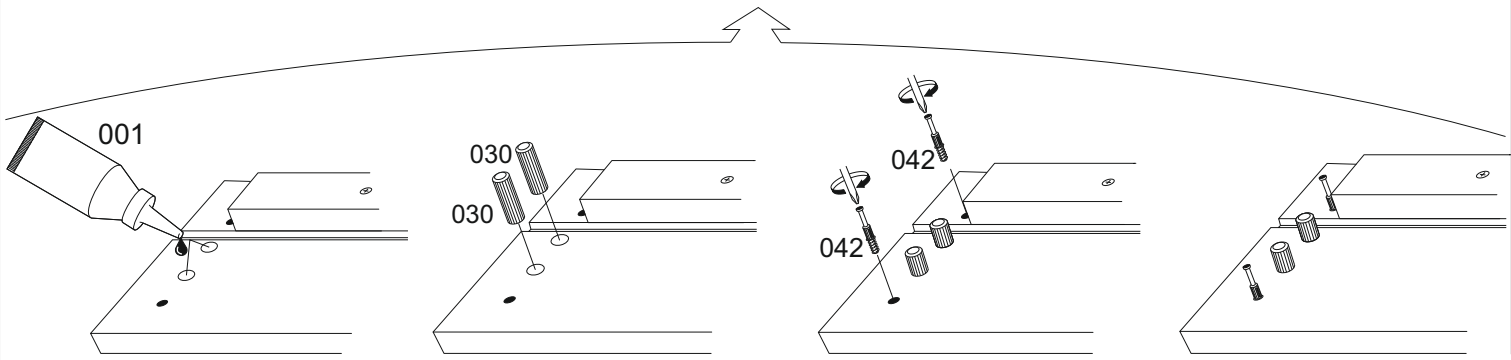
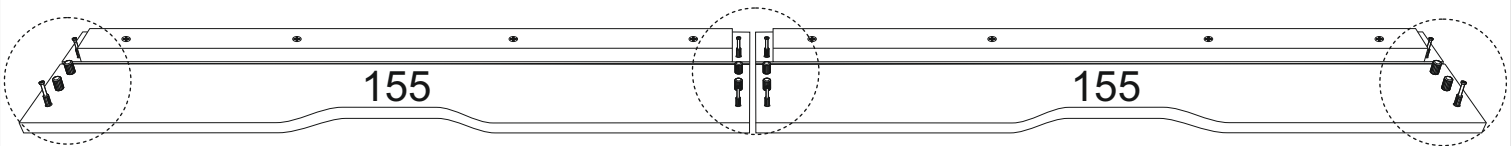
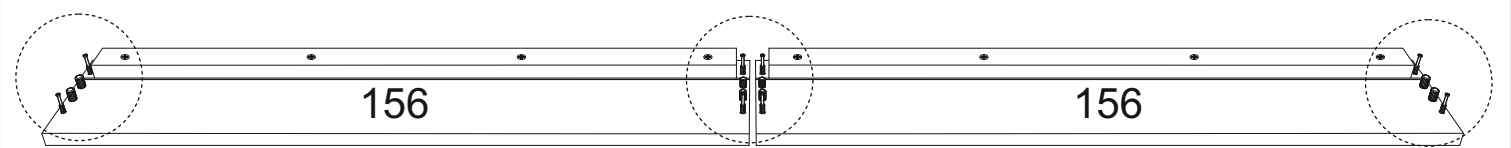
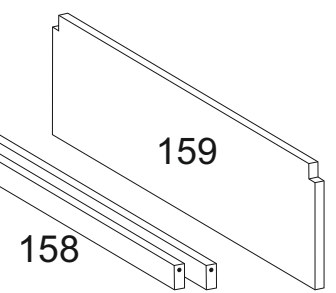
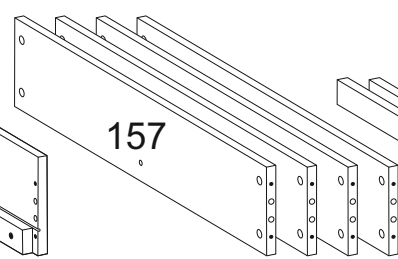
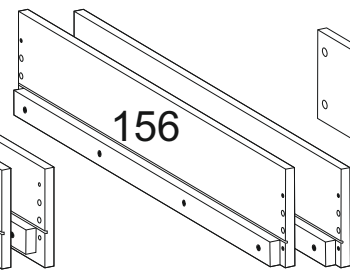
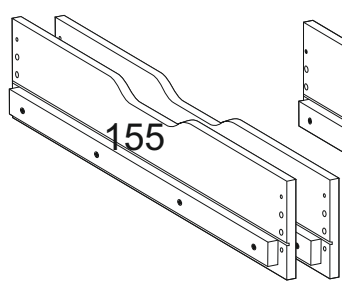
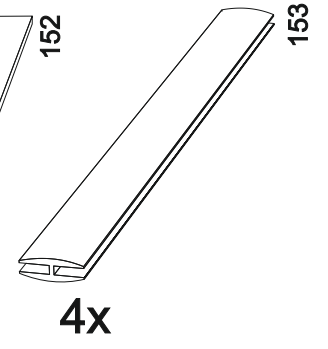
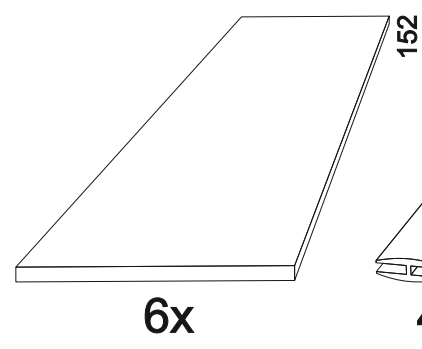
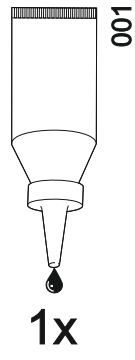
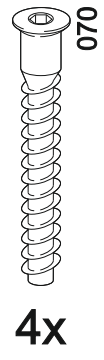
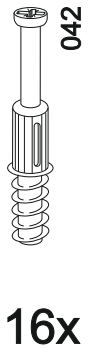
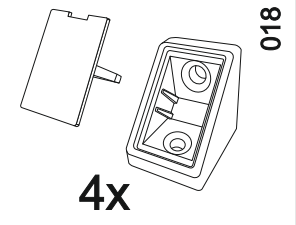
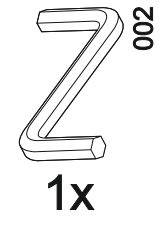
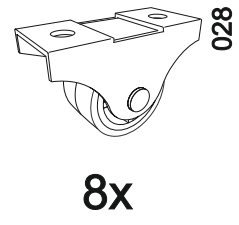
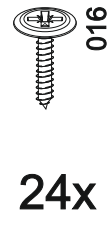
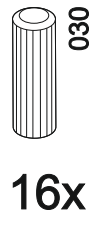

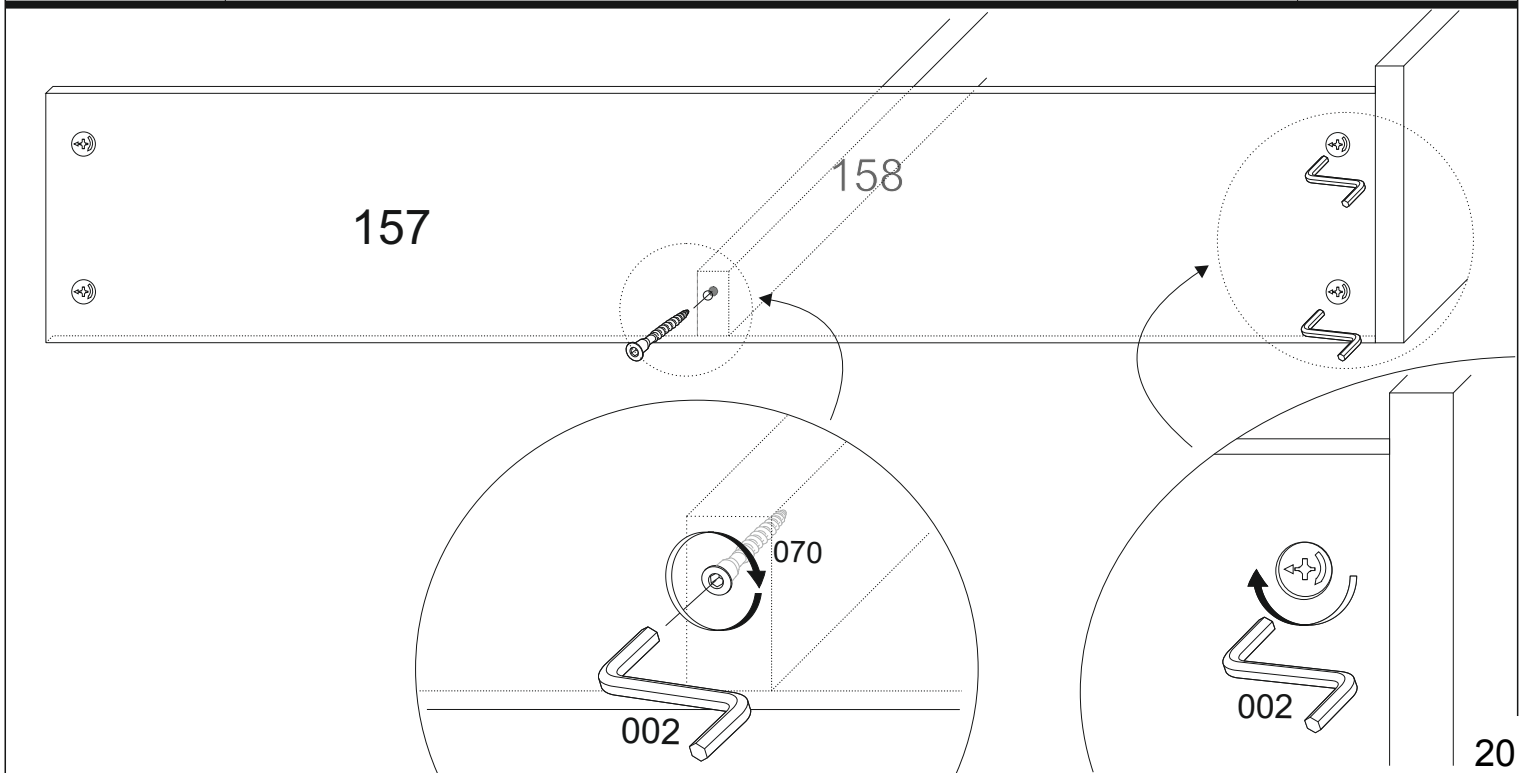
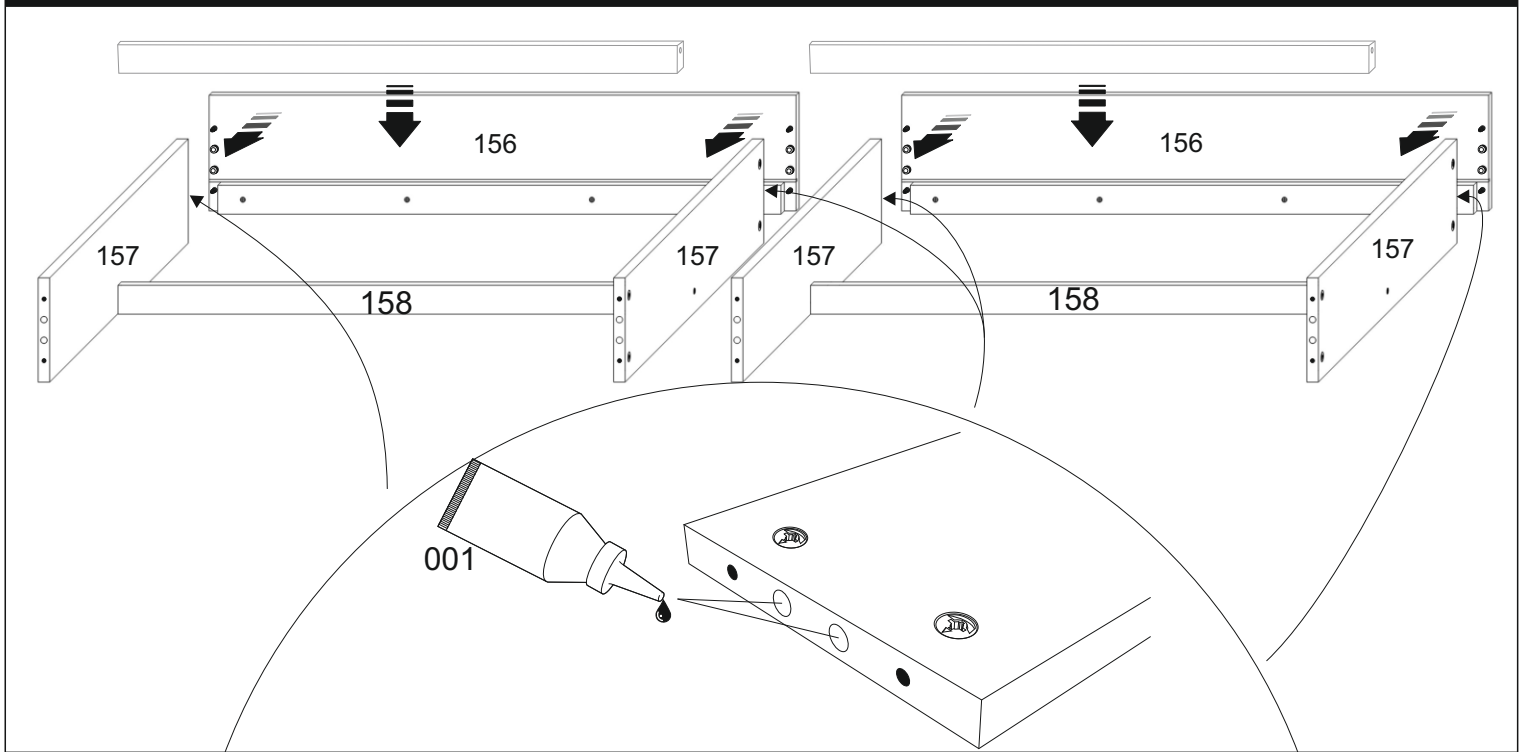
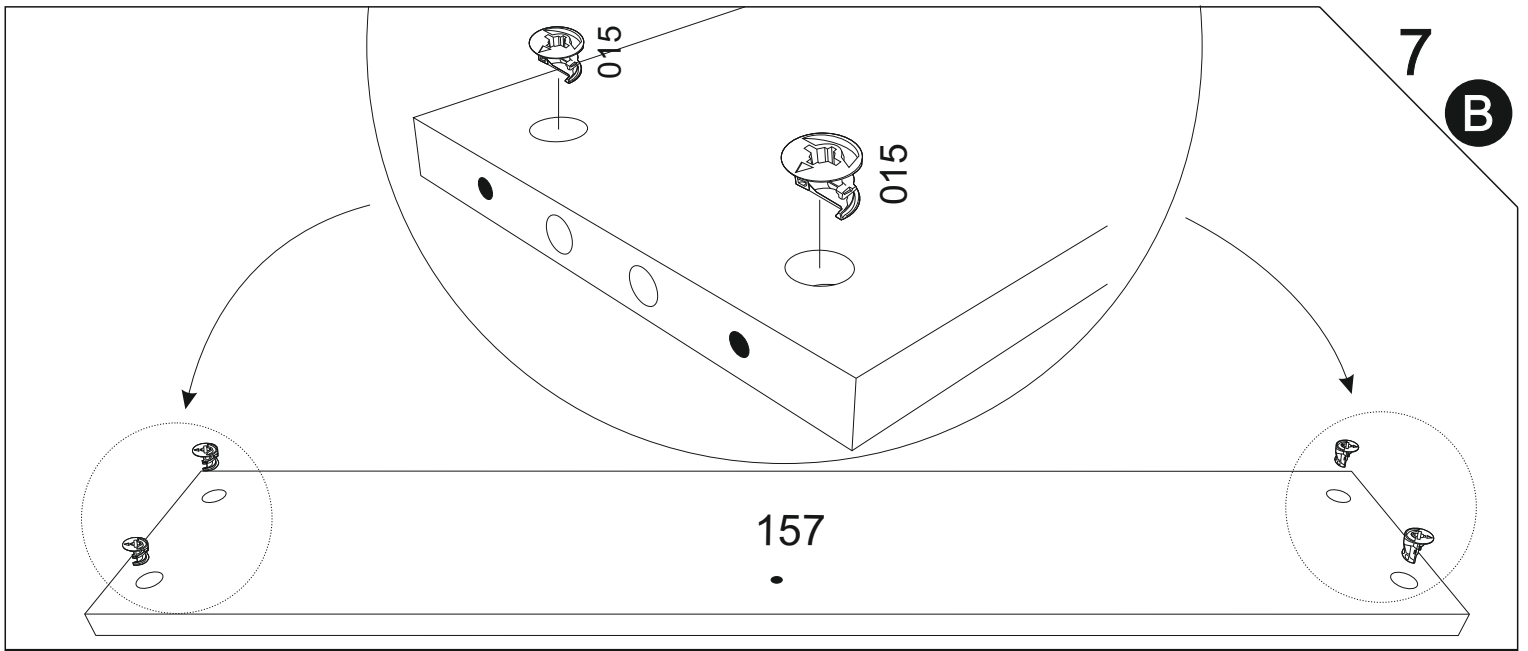

**B** 8

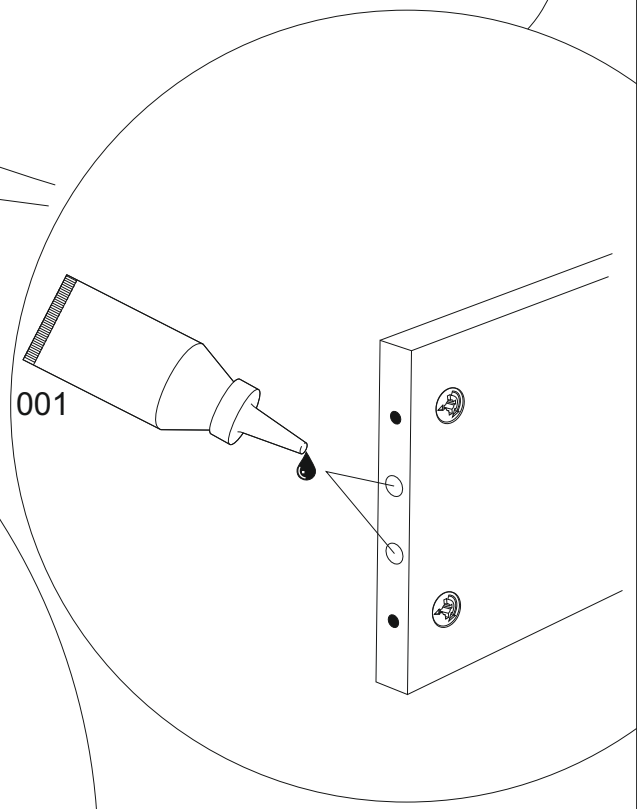
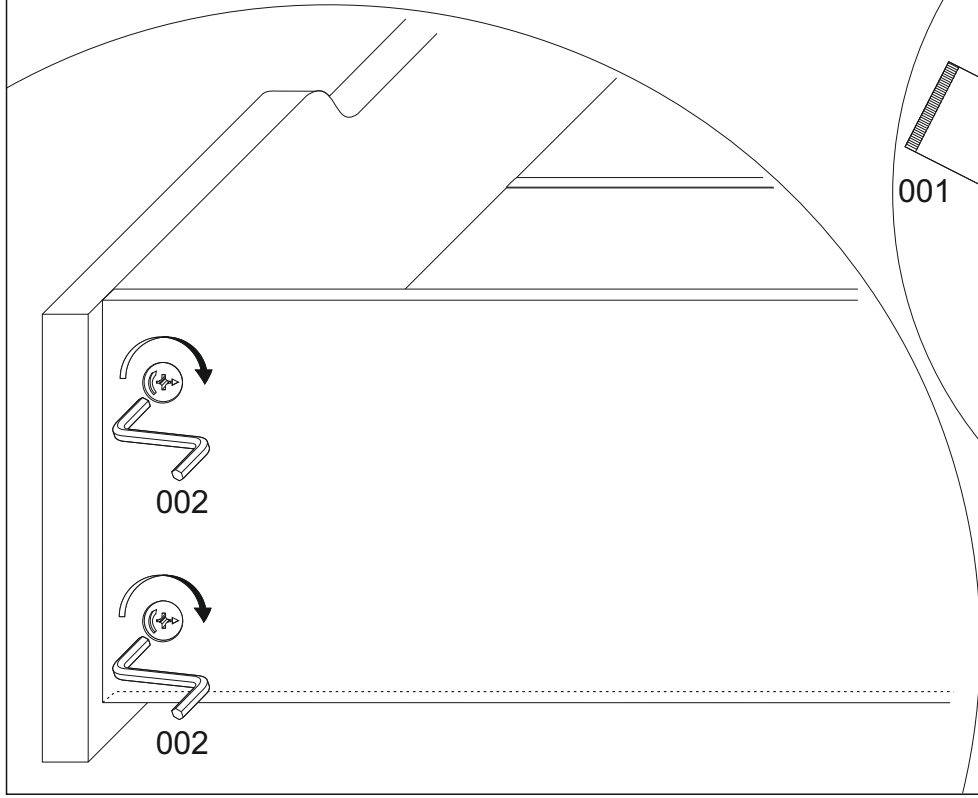
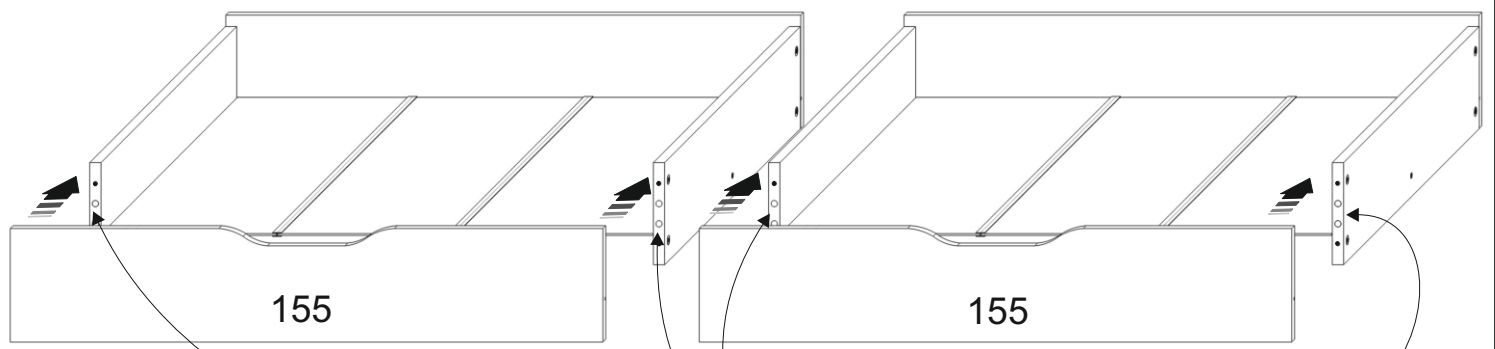
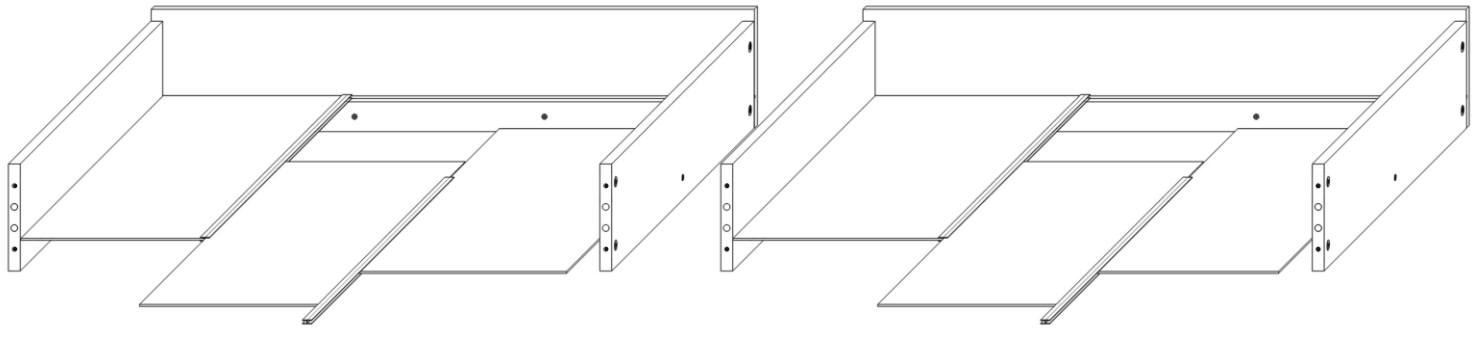
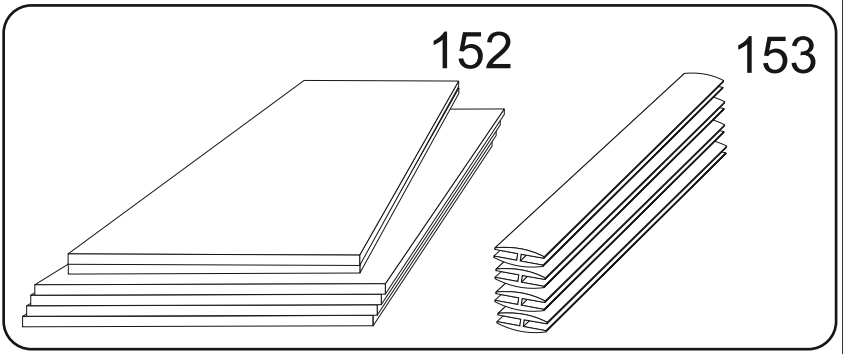

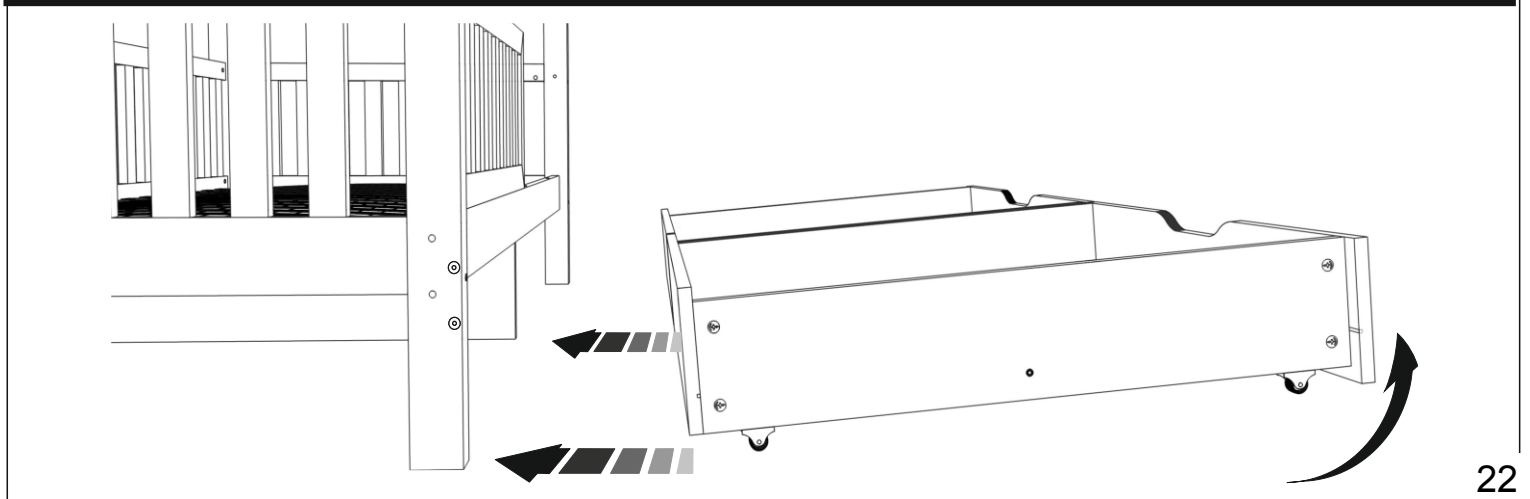
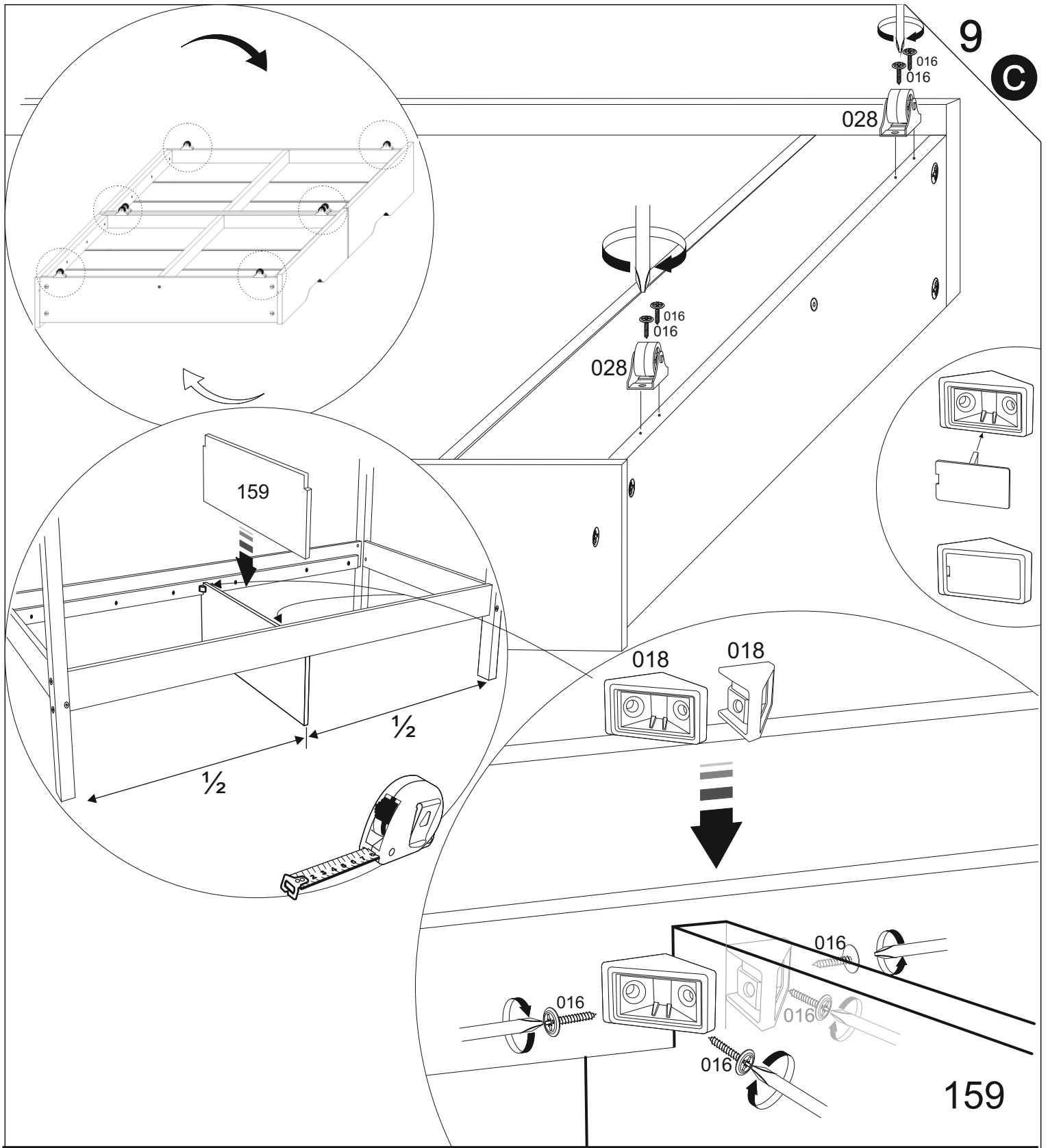

**C** 10

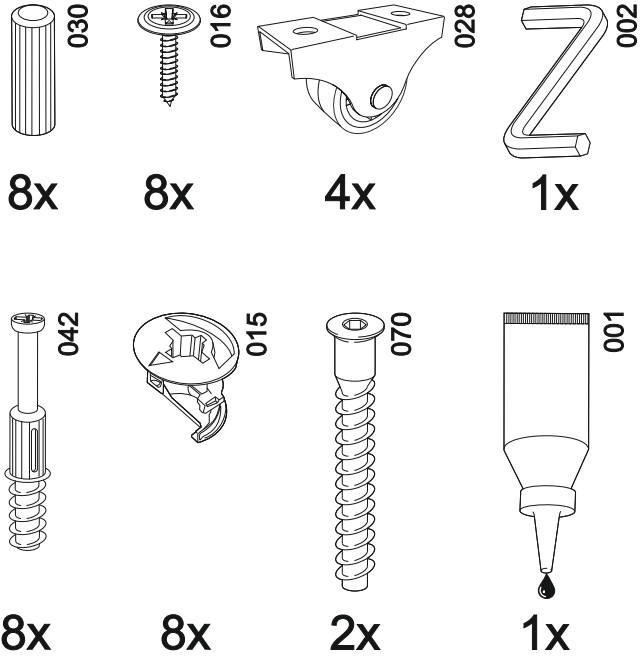

	055		090
← 140 →	28x	← 140 →	14x
← 160 →	32x	← 160 →	16x
← 180 →	36x	← 180 →	18x
← 190 →	38x	← 190 →	19x
← 200 →	40x	← 200 →	20x

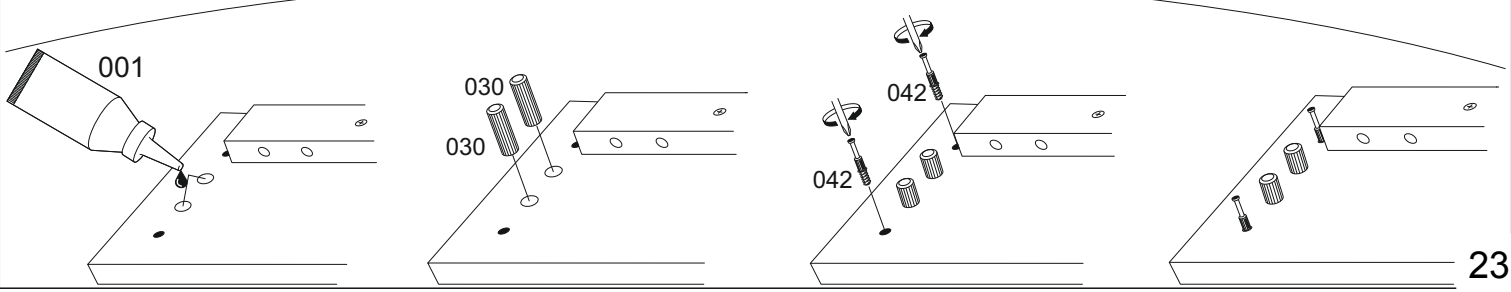
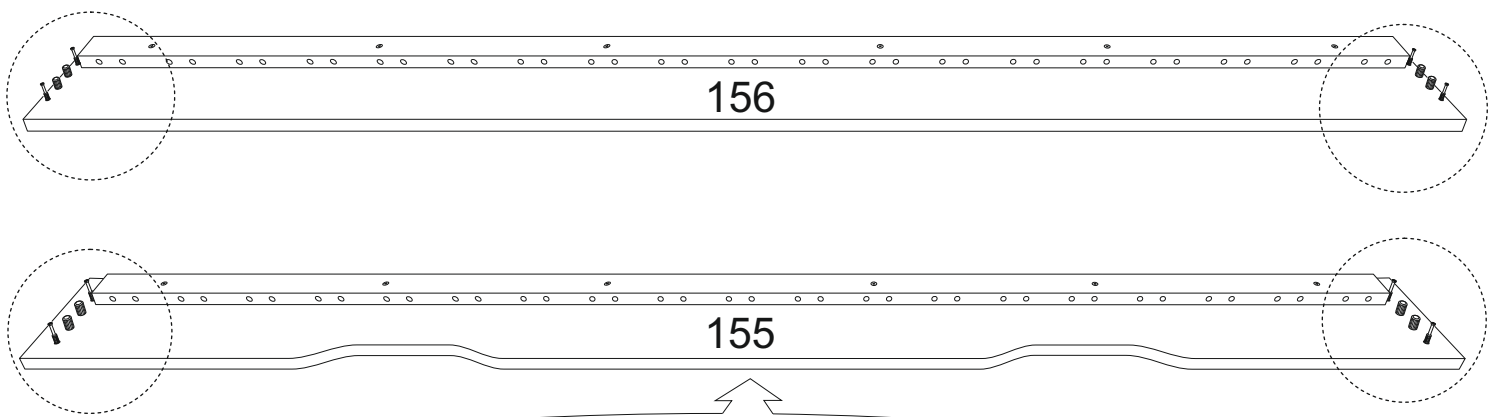
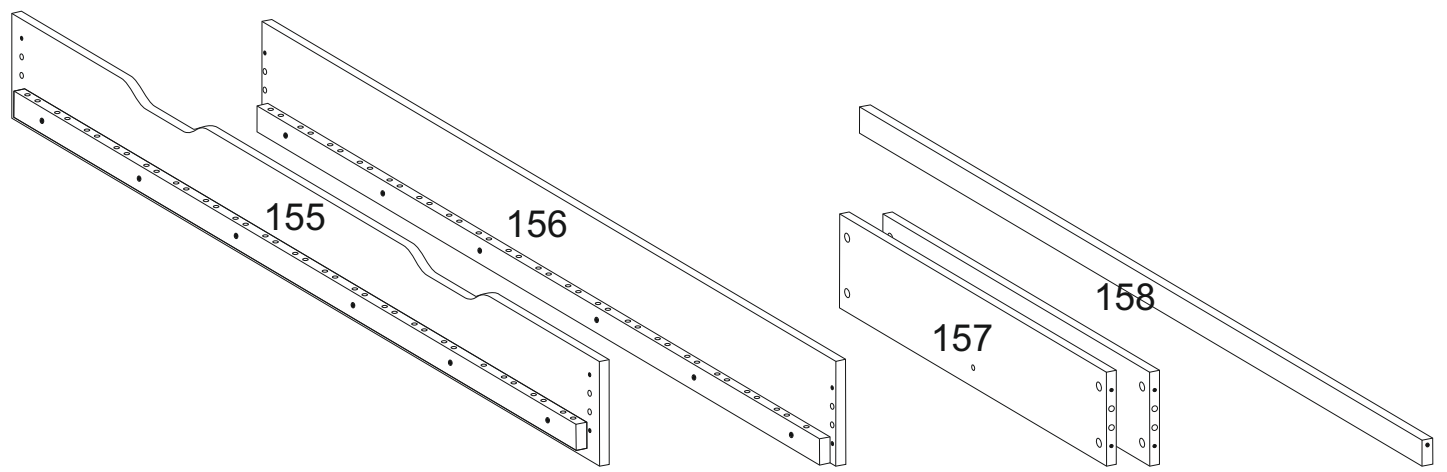

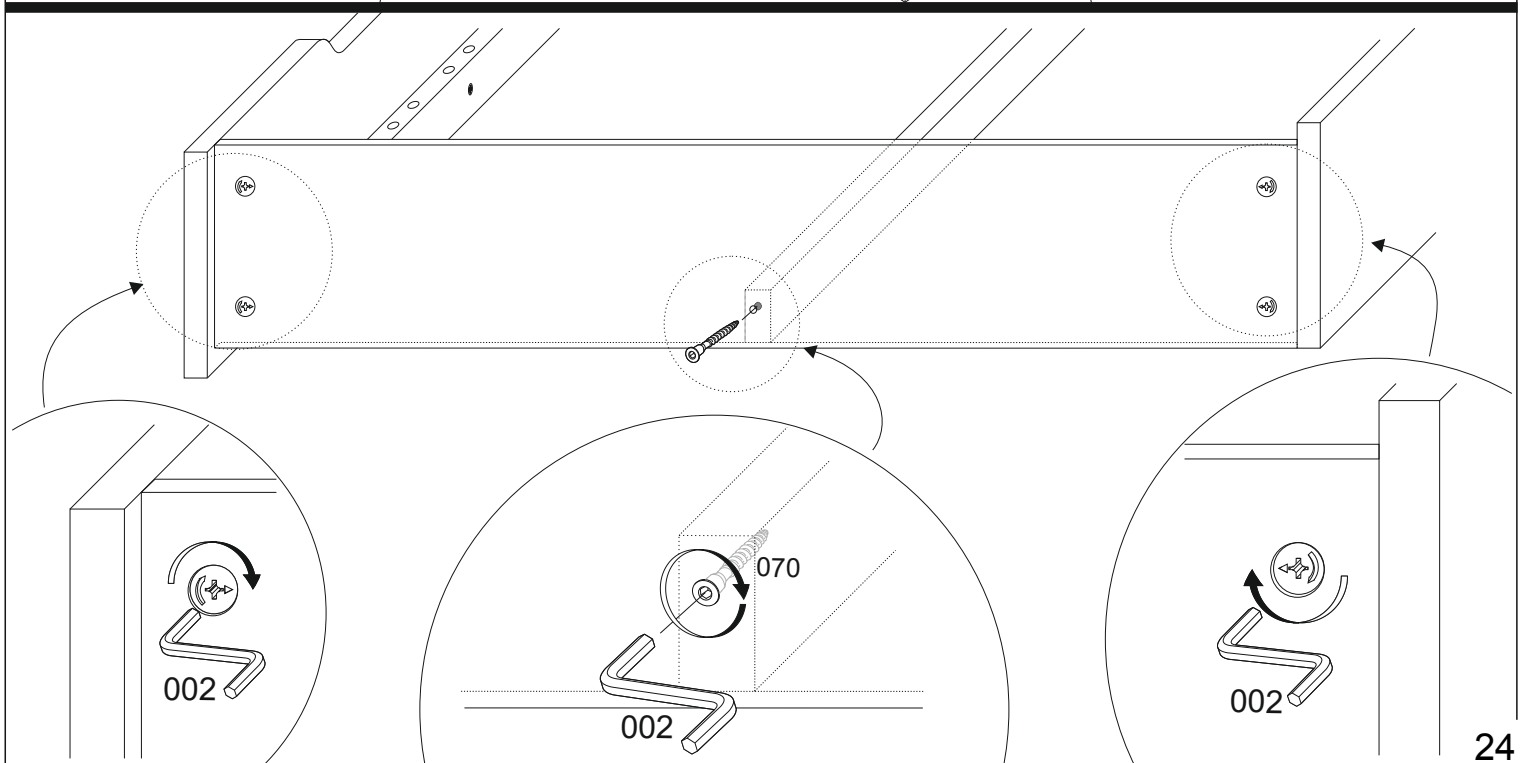
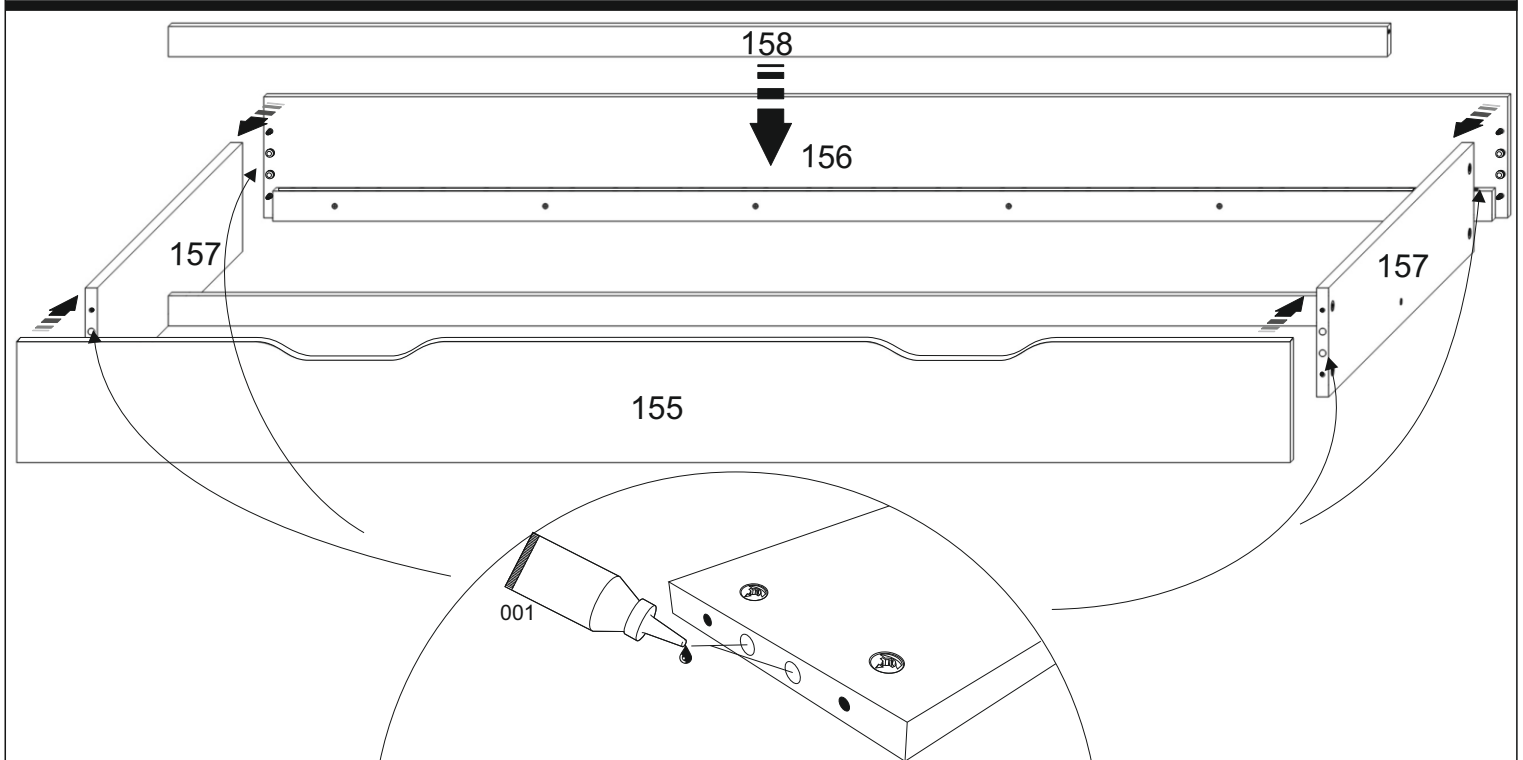
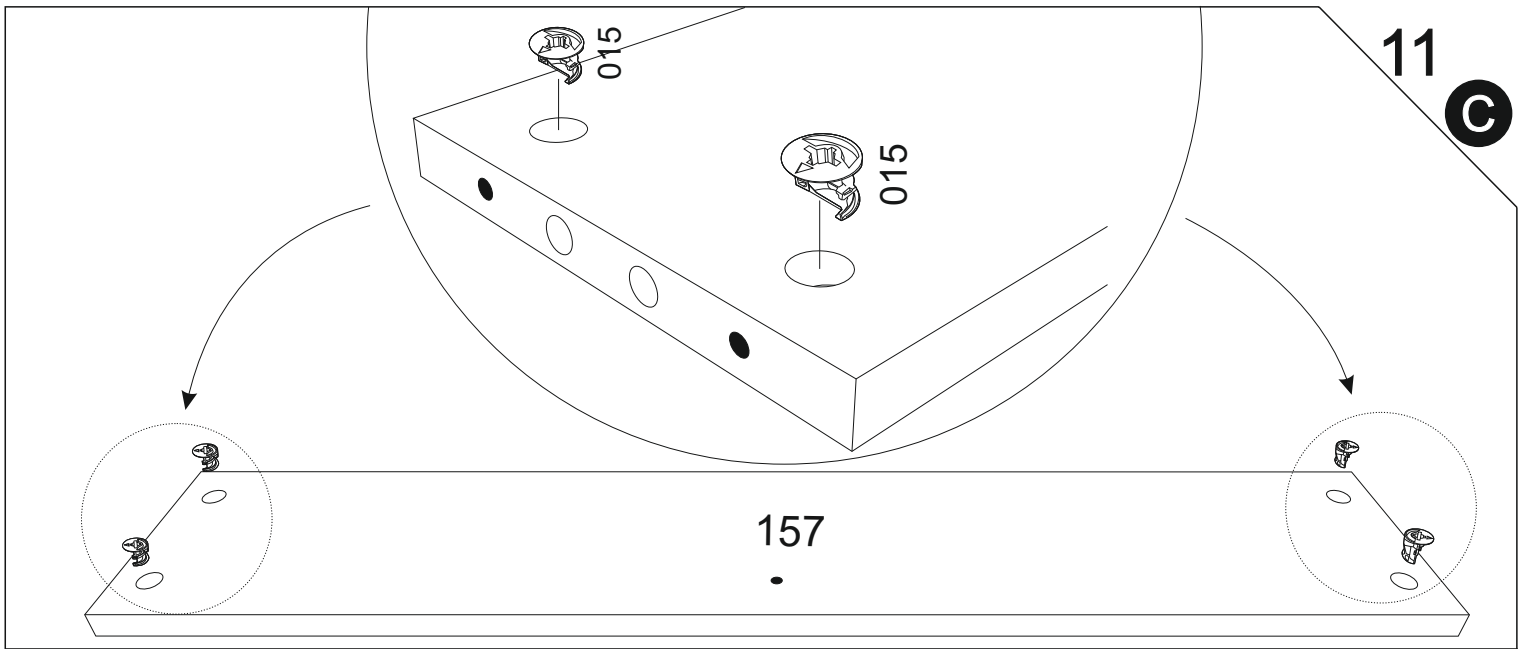



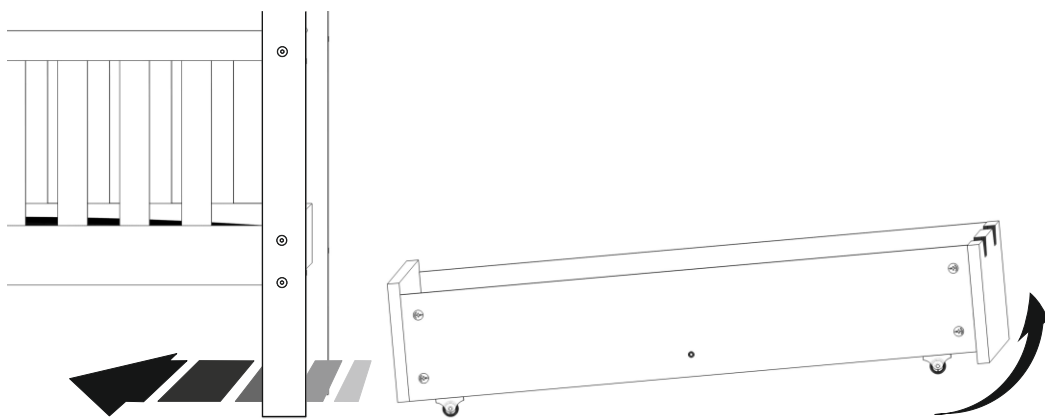
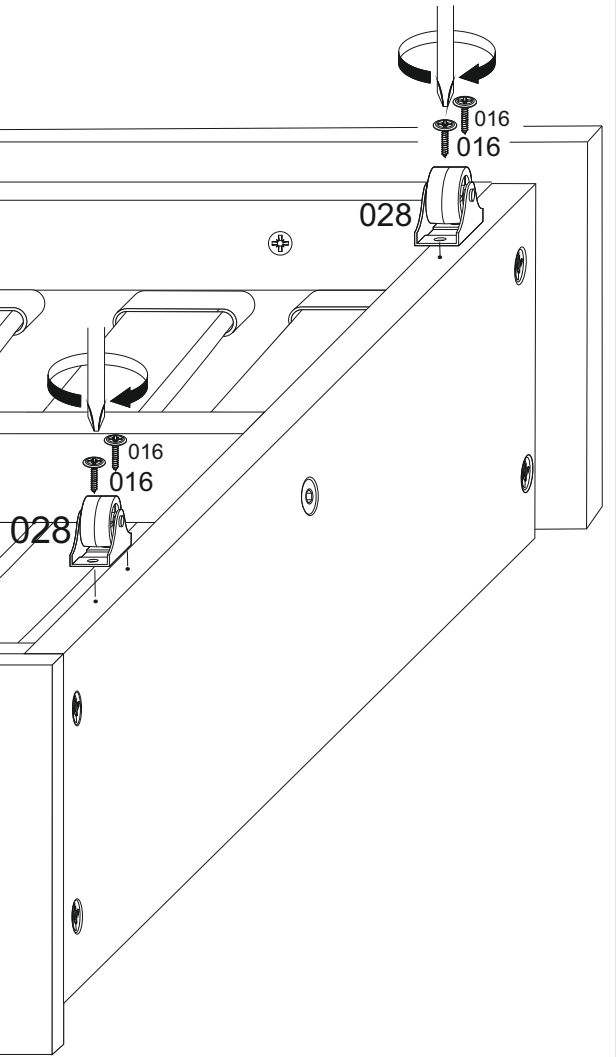
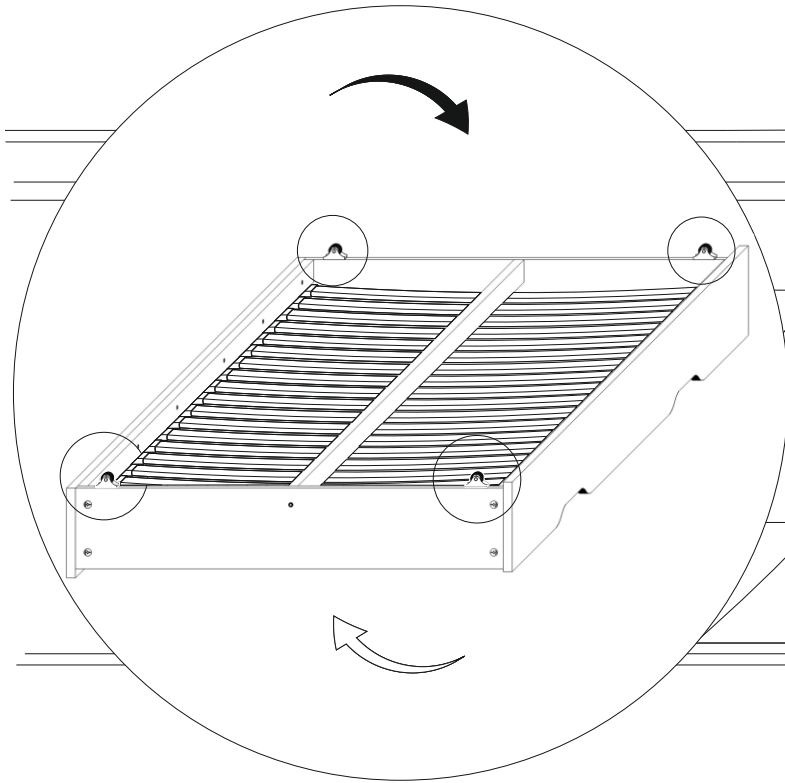
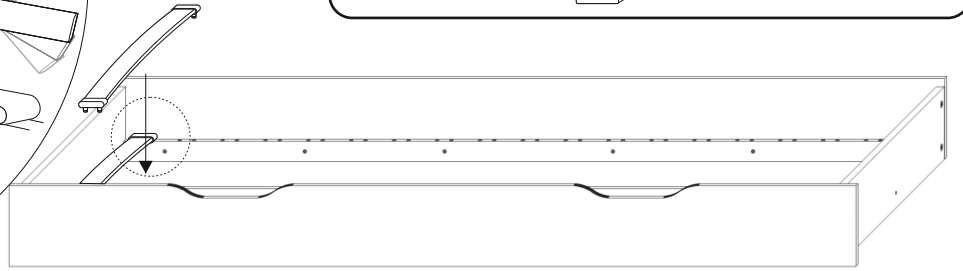
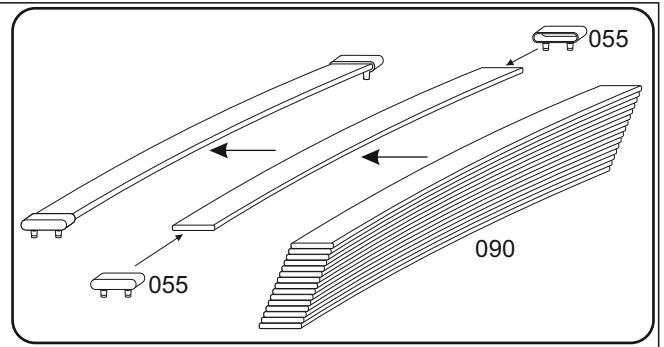
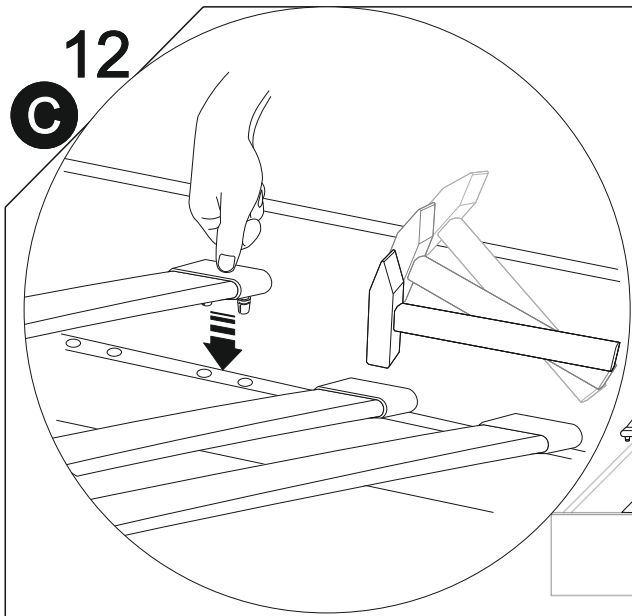

CATO: entry in the middle

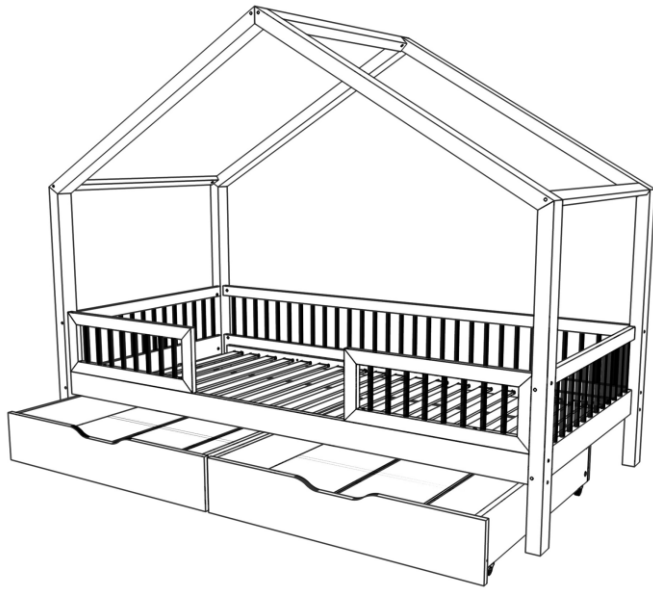
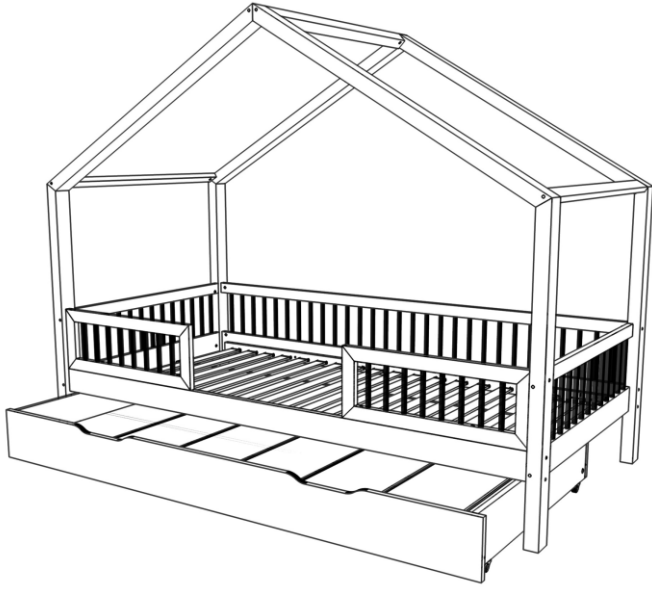
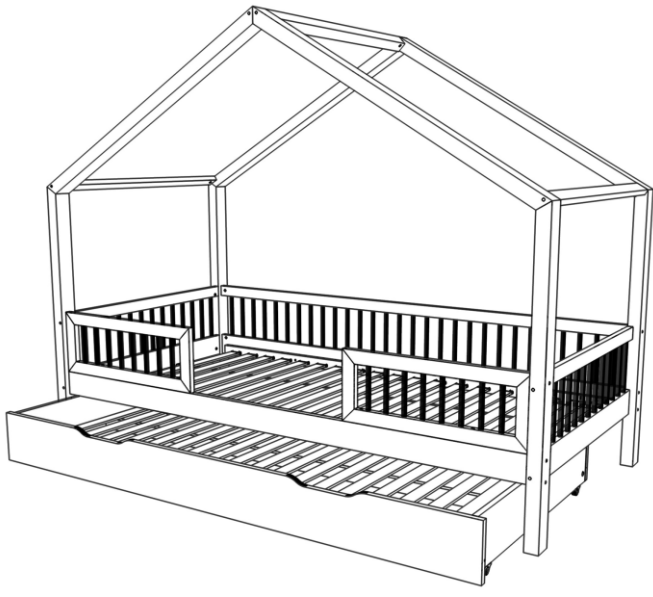
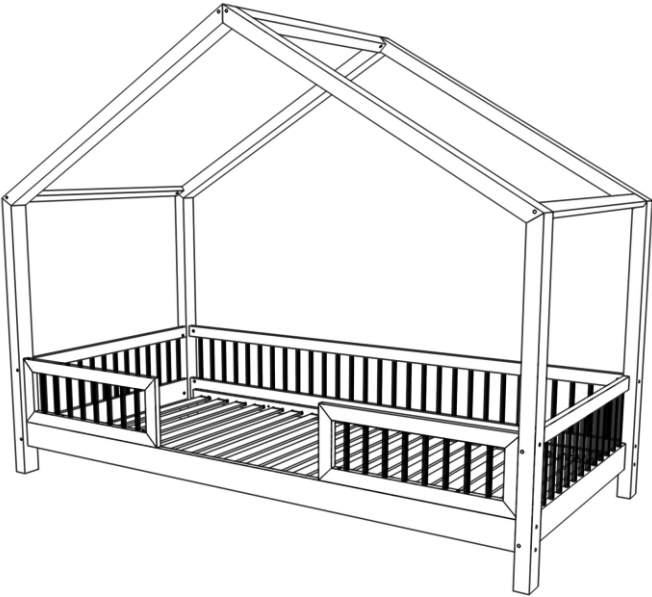



## IMPORTANT! KEEP FOR FUTURE REFERENCE: READ CAREFULLY.

- a. Warning: Be aware of the risks posed by open fire and other heat sources such as electric or gas heaters etc. near the bed.
- b. Warning: Do not use the bed if any part is damaged, torn or missing, use only the parts approved by the manufacturer.
- c. Warning: Do not leave anything in the bed or place the bed near any other equipment that could support the foot or pose a risk of suffocation or hanging the child, such as cords, curtain / blind cords.
- d. Warning: Do not use more than one mattress in the bed.
- e. Recommended maximum mattress thickness of 12 cm - 15 cm.
- f. The selected bed size is the size of the mattress to be used.
- g. It is recommended that all assembly elements be tightened well during assembly, regularly checked and tightened if necessary.

**Warning:** Before starting the assembly, please check all the elements. If any parts are damaged, please do not assemble the bed, and notify us of the damaged parts immediately by email, with photos, so that we can send you replacement parts. Once the bed has been assembled, any complaint regarding damages parts will no longer be accepted.



## IMPORTANTE! GUARDE PARA REFERÊNCIA FUTURA: LEIA ATENTAMENTE.

- a. Aviso: Esteja ciente dos riscos representados por fogo aberto e outras fontes de calor, como aquecedores elétricos ou a gás, etc. perto da cama.
- b. Atenção: Não use a cama se alguma peça estiver danificada, rasgada ou faltando, use apenas as peças aprovadas pelo fabricante.
- c. Aviso: Não deixe nada na cama ou coloque a cama perto de qualquer outro equipamento que possa apoiar o pé ou oferecer risco de asfixia ou pendurar a criança, como cordas, cortinas/cortinas.
- d. Aviso: Não use mais de um colchão na cama.
- e. Espessura máxima recomendada do colchão de 12 cm - 15 cm.
- f. O tamanho da cama selecionada é o tamanho do colchão a ser usado.
- g. Recomenda-se que todos os elementos de montagem sejam bem apertados durante a montagem, verificados regularmente e apertados se necessário.

**Atenção:** Antes de iniciar a montagem, verificar todas as peças. Se houver peças danificadas, não montar a cama e notificar-nos imediatamente por e-mail para que possamos enviar-lhe novas peças. Uma vez a cama montada, não poderá ser aceita mais nenhuma reclamação.

# WICHTIG! FÜR SPÄTERES NACHSCHLAGEN AUFBEWAHREN: SORGFÄLTIG LESEN.

- a. **Warnung:** Seien Sie sich der Risiken bewusst, die durch offenes Feuer und andere Wärmequellen wie Elektro- oder Gasheizungen usw. in der Nähe des Bettes entstehen.
- b. **Warnung:** Verwenden Sie das Bett nicht, wenn Teile beschädigt, gerissen oder fehlen, verwenden Sie nur die vom Hersteller zugelassenen Teile.
- c. **Warnung:** Lassen Sie nichts im Bett liegen und stellen Sie das Bett nicht in die Nähe anderer Geräte, die den Fuß stützen oder eine Erstickungsgefahr oder das Aufhängen des Kindes darstellen könnten, wie z.B. Drähte, Gardinen-/Rolloschnüre.
- d. **Warnung:** Verwenden Sie nicht mehr als eine Matratze im Bett.
- e. Empfohlene maximale Matratzendicke von 12 cm - 15 cm.
- f. Die gewählte Bettgröße ist die Größe der zu verwendenden Matratze.
- g. Es wird empfohlen, alle Montageelemente während der Montage gut anzuziehen, regelmäßig zu kontrollieren und ggf. nachzuziehen.

**Achtung:** Bitte prüfen Sie vor dem Aufbau ob Sie alle Elemente erhalten haben. Sollten einige Teile beschädigt sein, bitten wir Sie das Bett vorerst nicht aufzubauen und uns die Schäden schriftlich zu melden. Wir werden diese schnellstens ersetzen. Sollte das Bett bereits aufgebaut worden sein, so kann die Reklamation nicht akzeptiert werden.

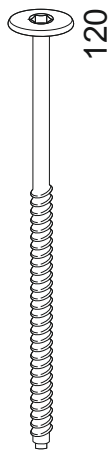

4x

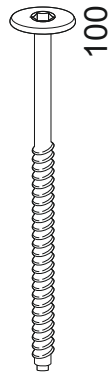

18x

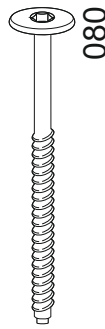

10x

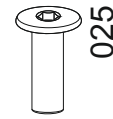

4x

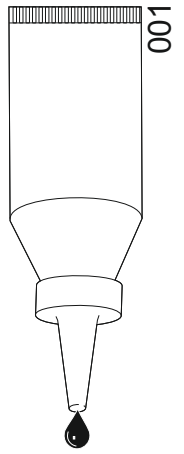

1x



28x

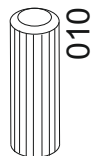

20x

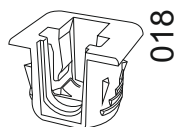

8x

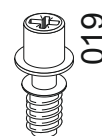

8x



1x

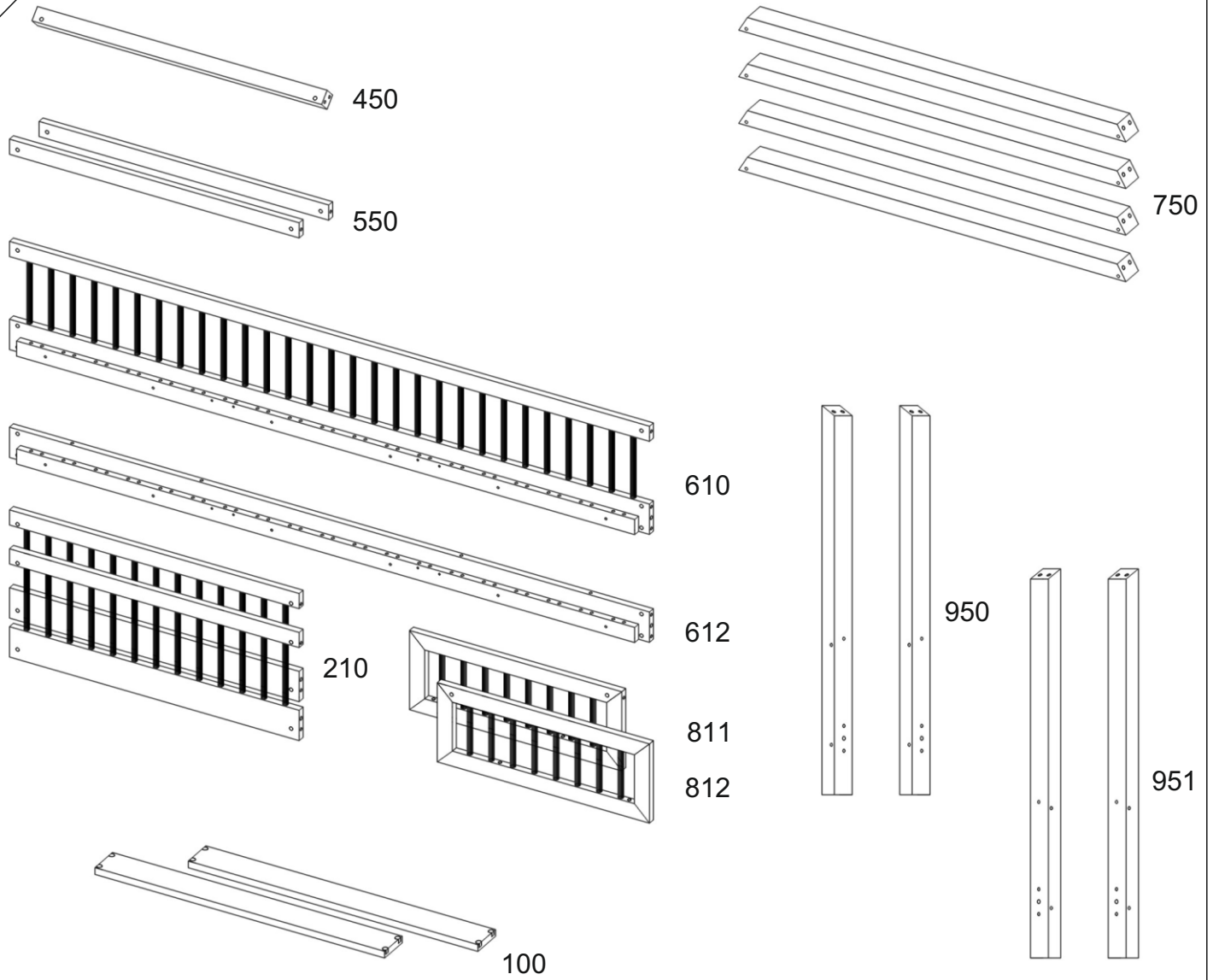

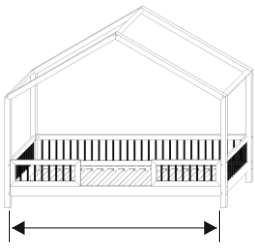
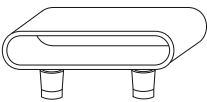
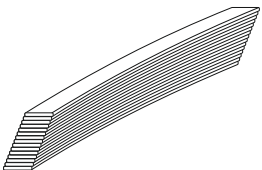
	 055	 090
140cm	<b>28x</b>	<b>14x</b>
160cm	<b>32x</b>	<b>16x</b>
180cm	<b>34x</b>	<b>17x</b>
190cm	<b>38x</b>	<b>19x</b>
200cm	<b>40x</b>	<b>20x</b>

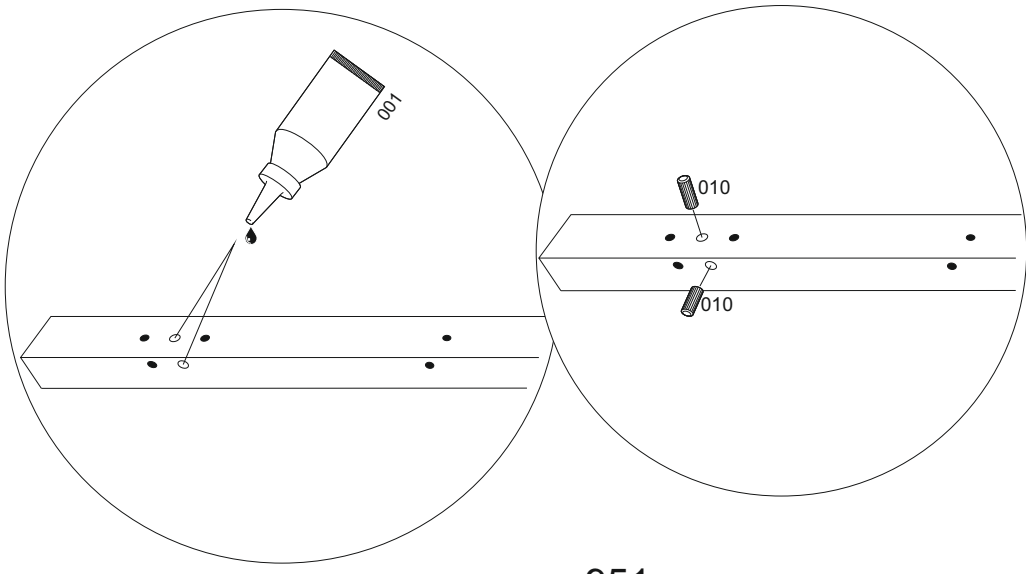

951

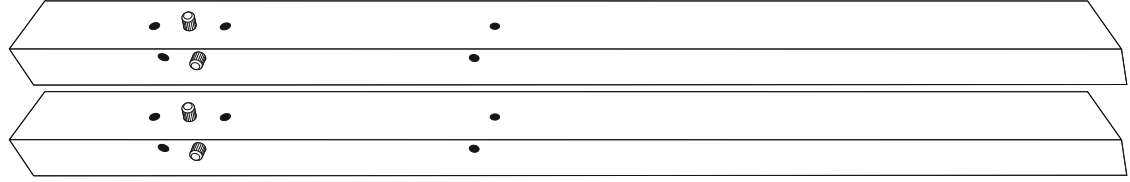

952

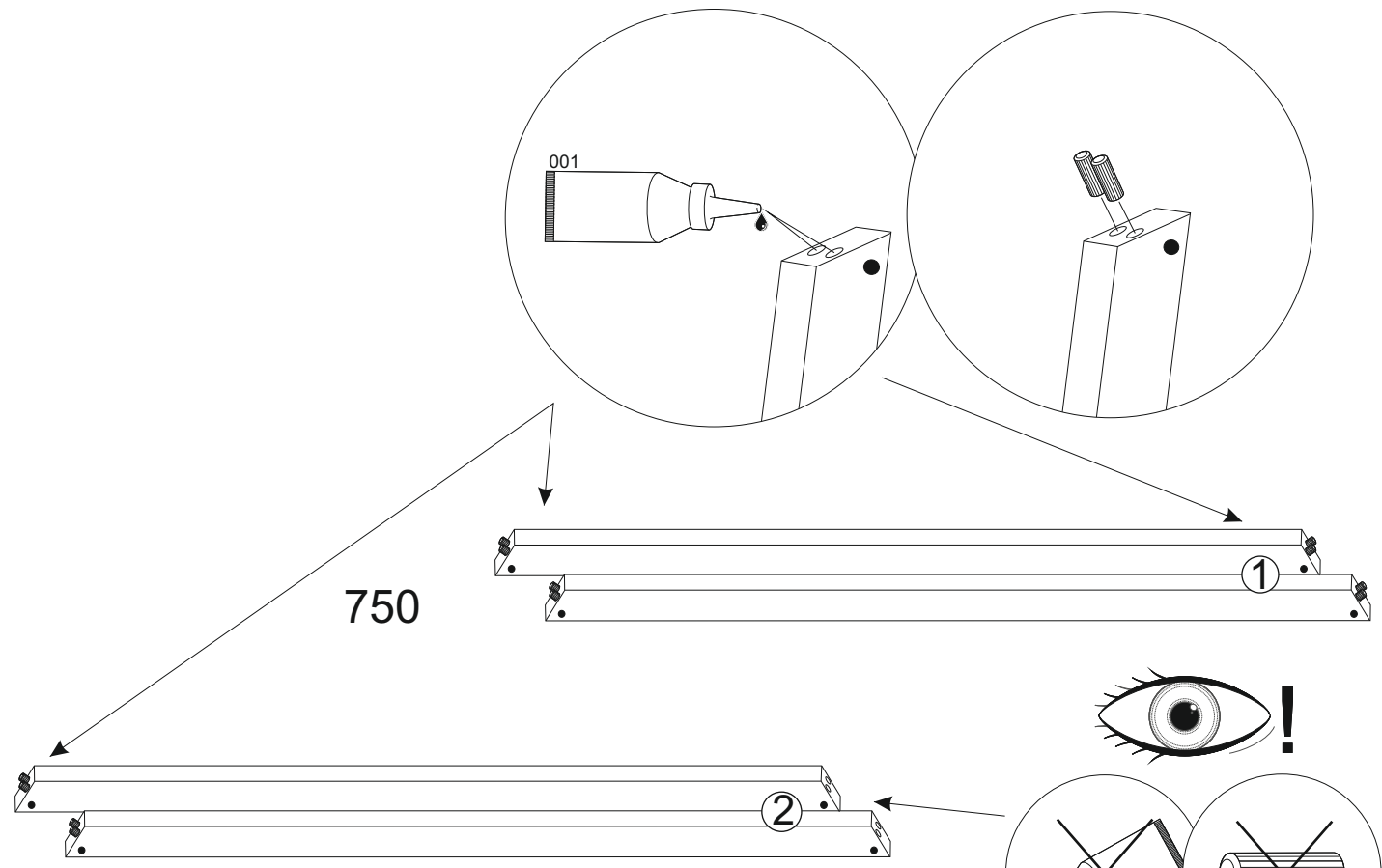
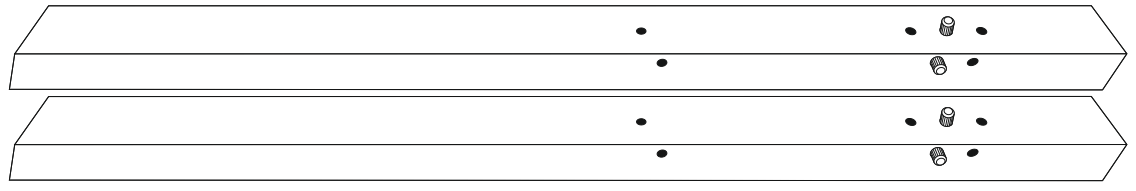

750

1

2

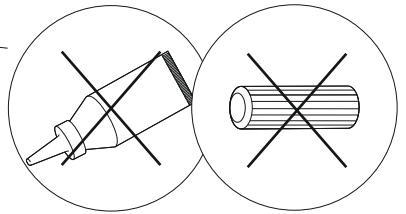

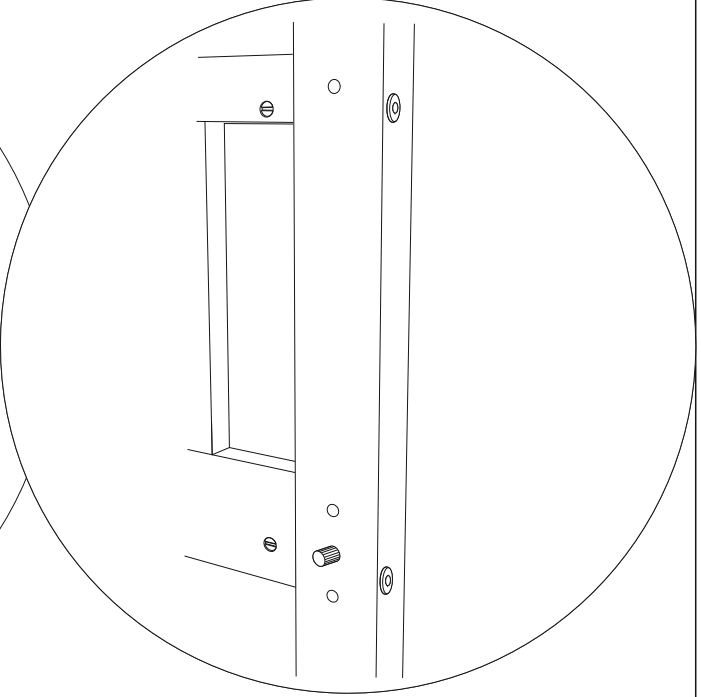
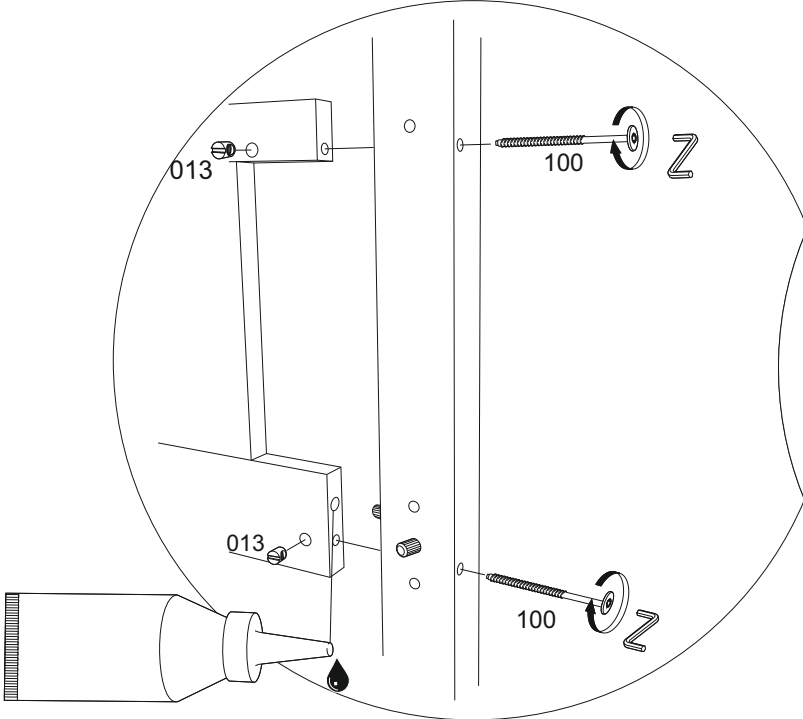
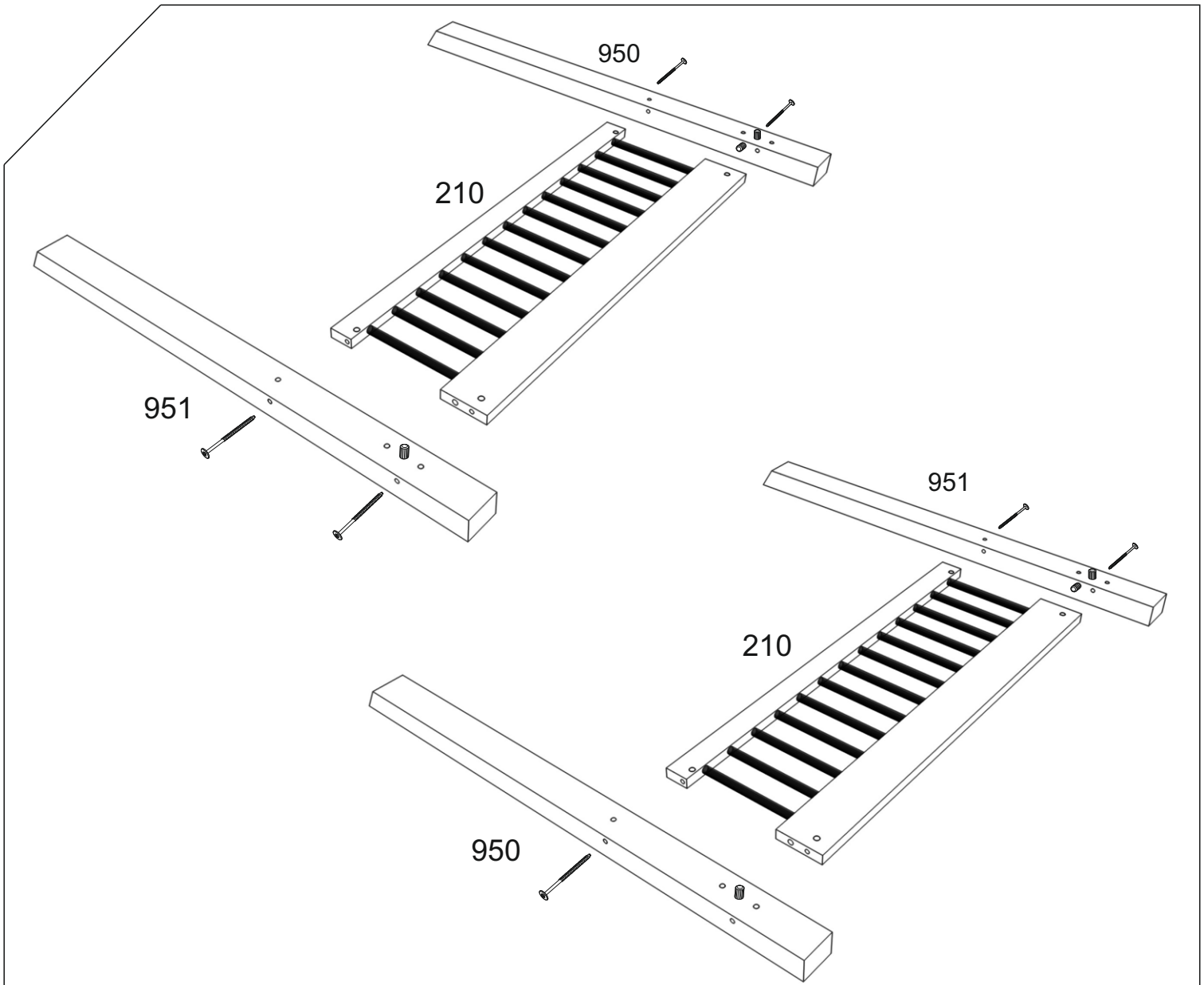

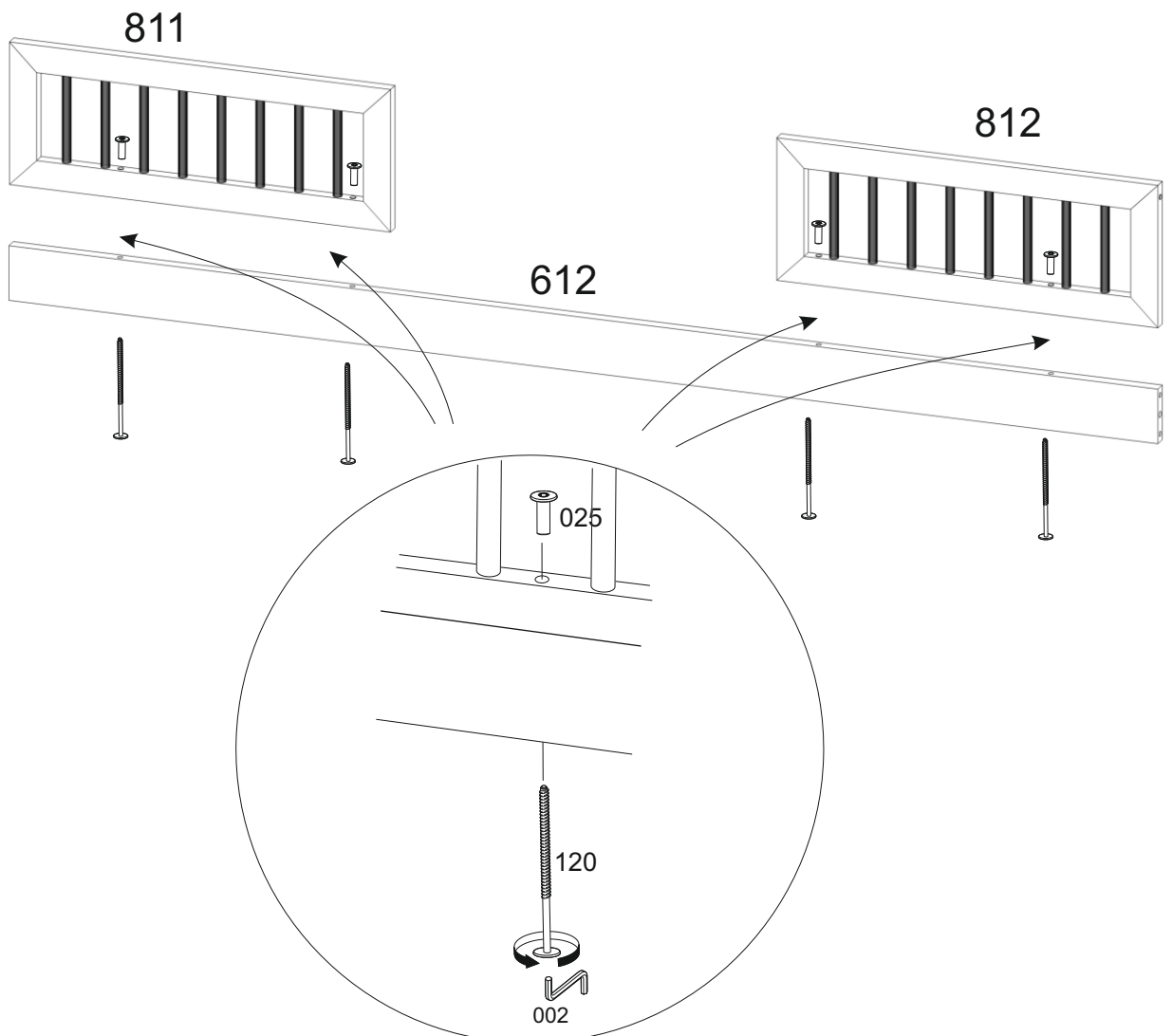
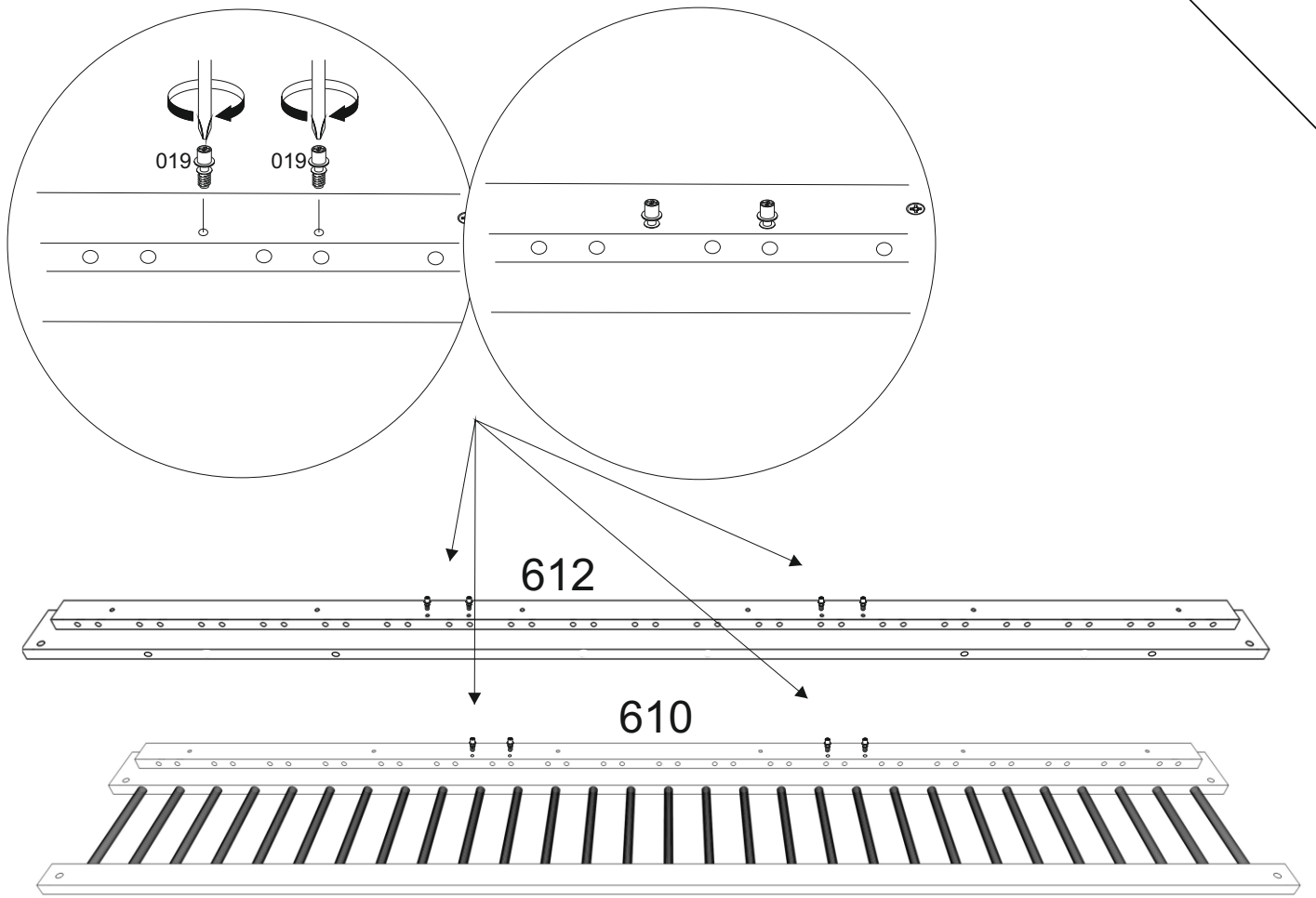



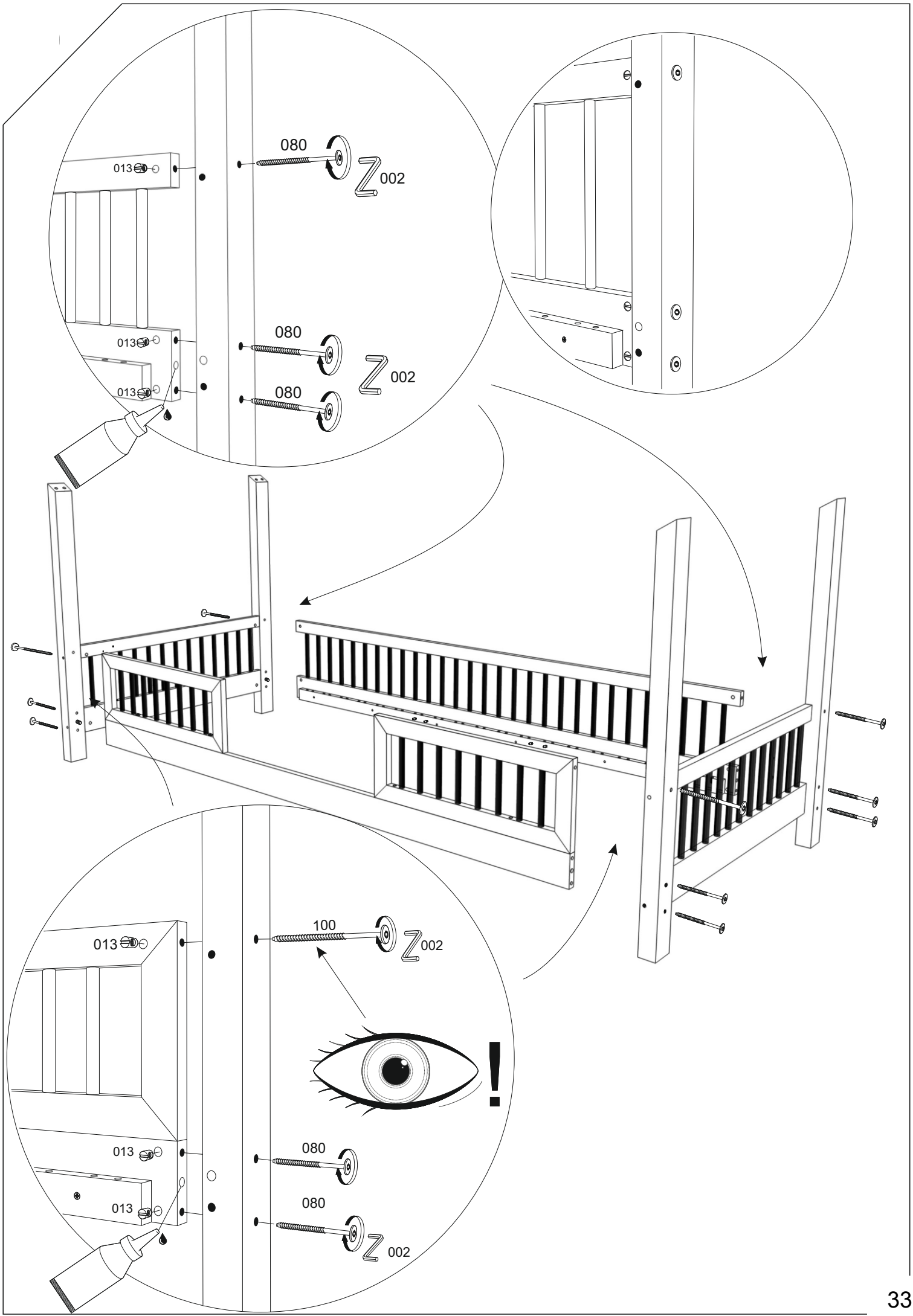

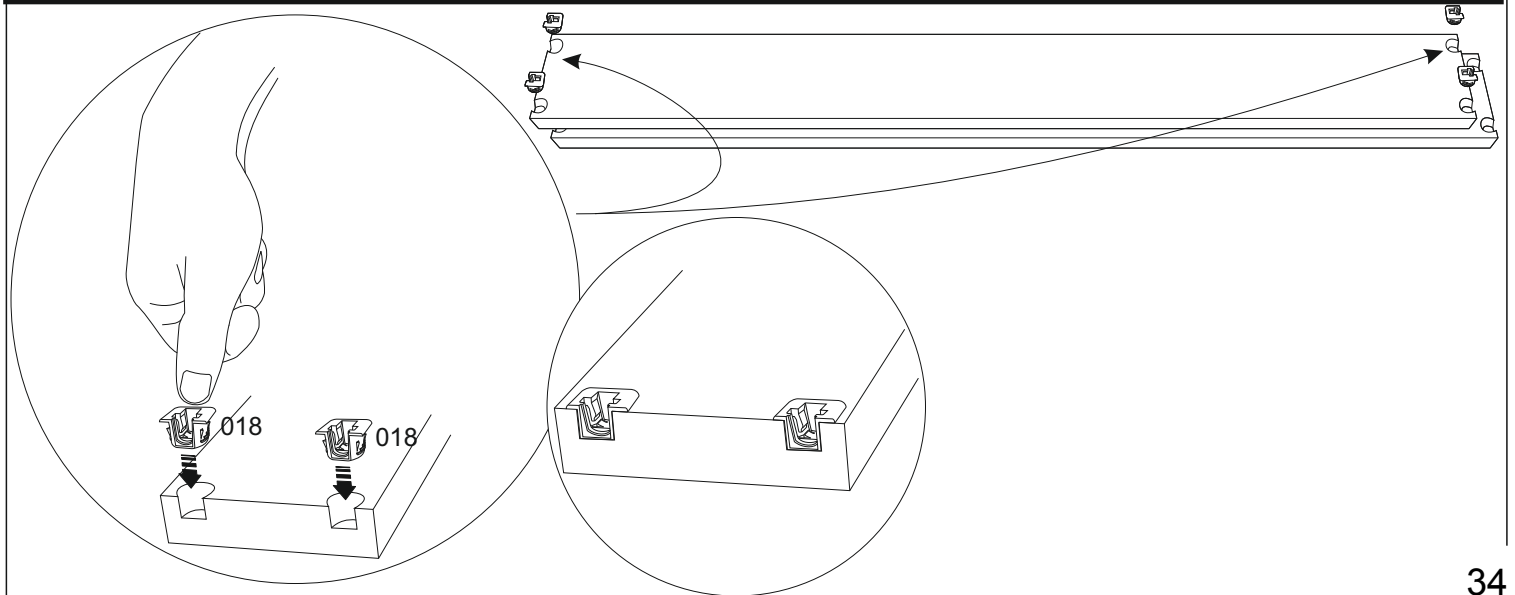
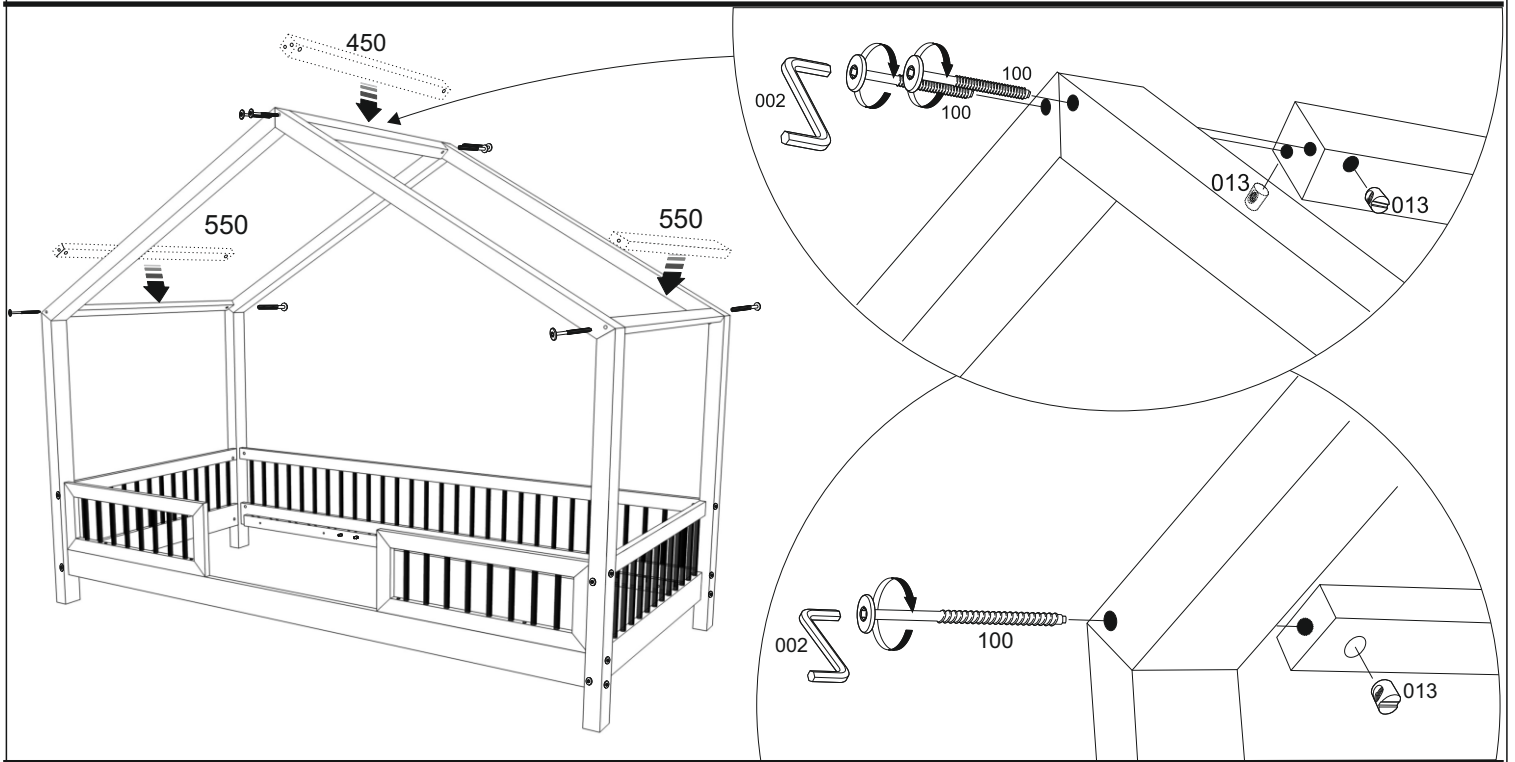
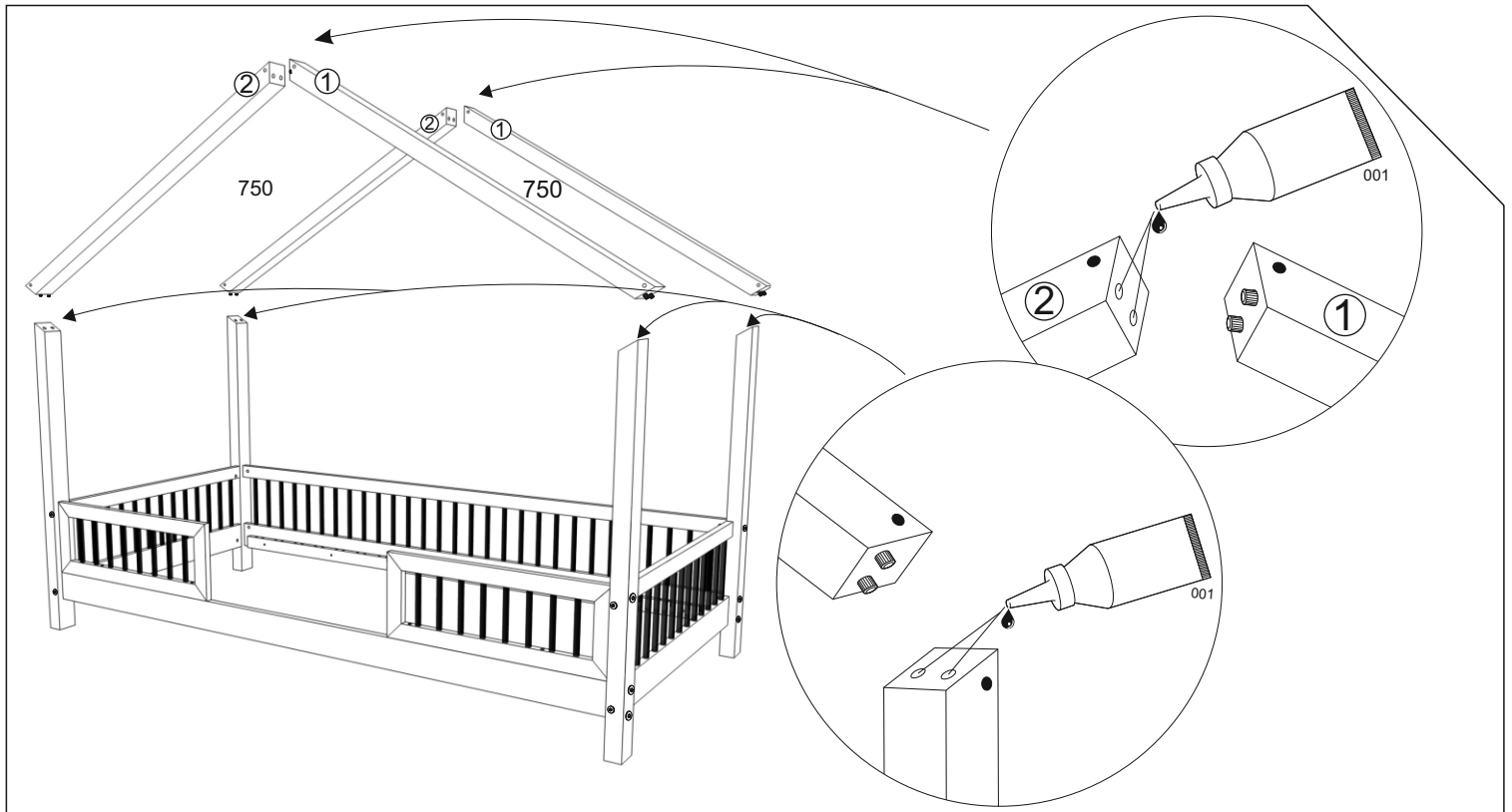

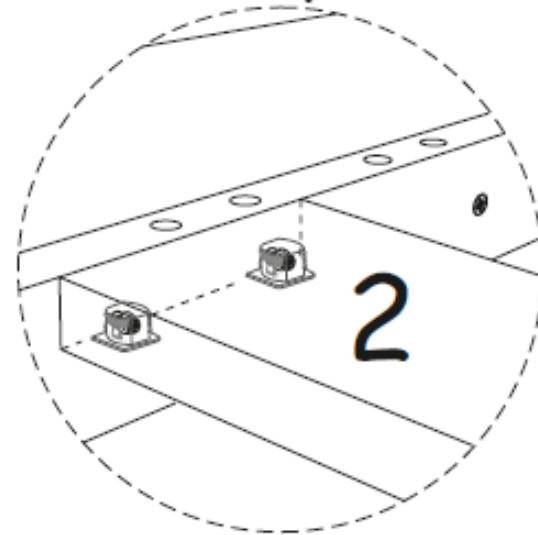
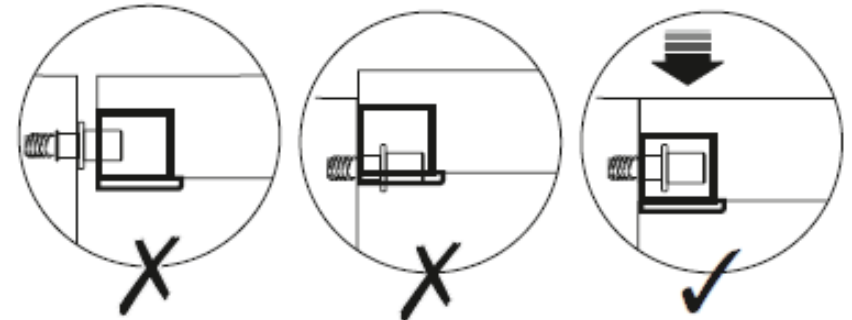
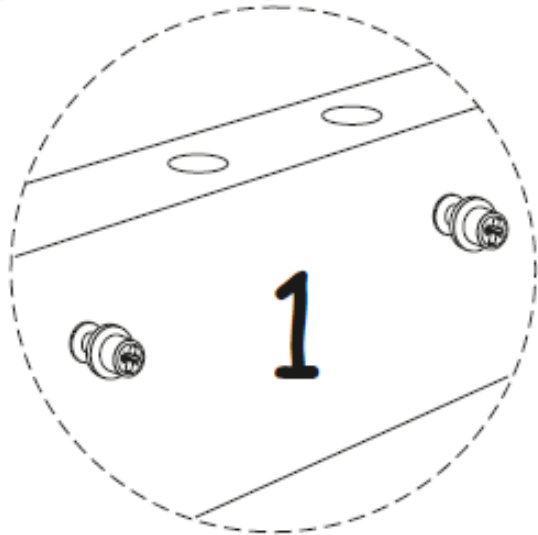
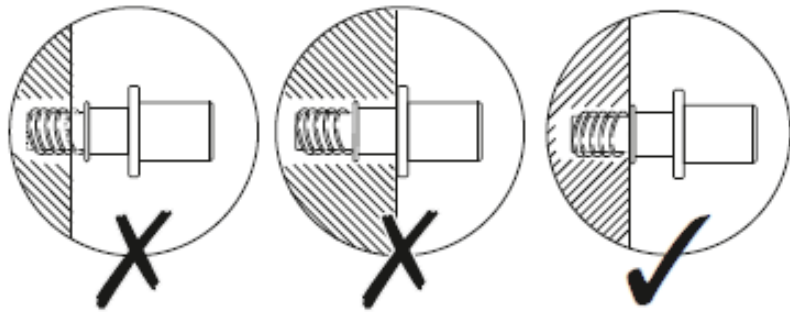
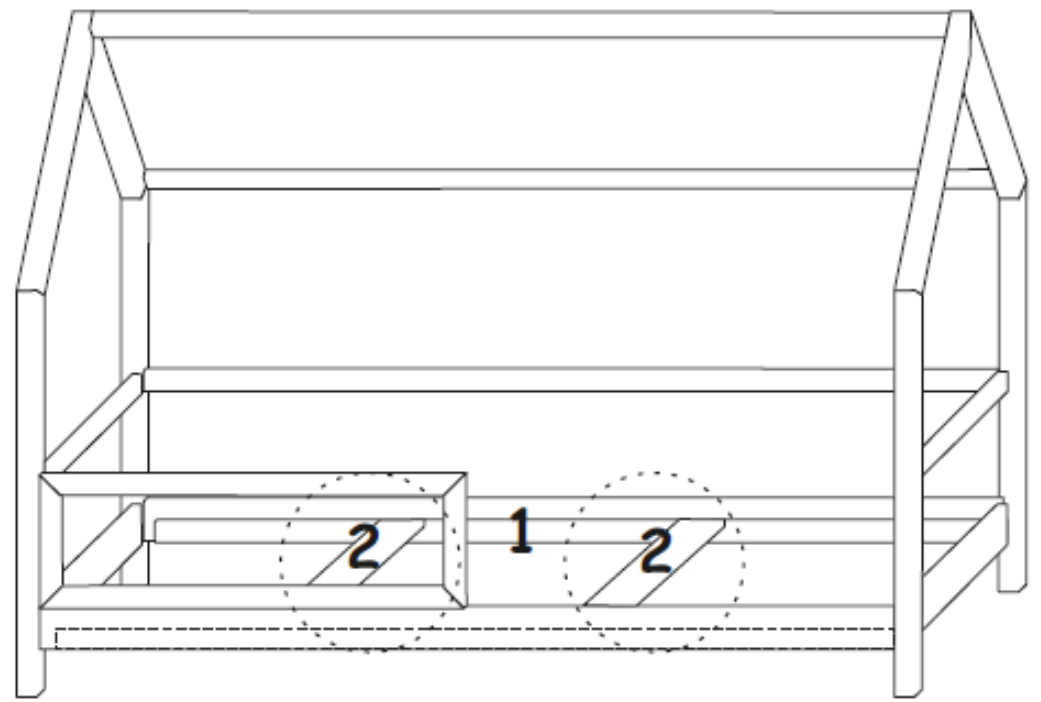

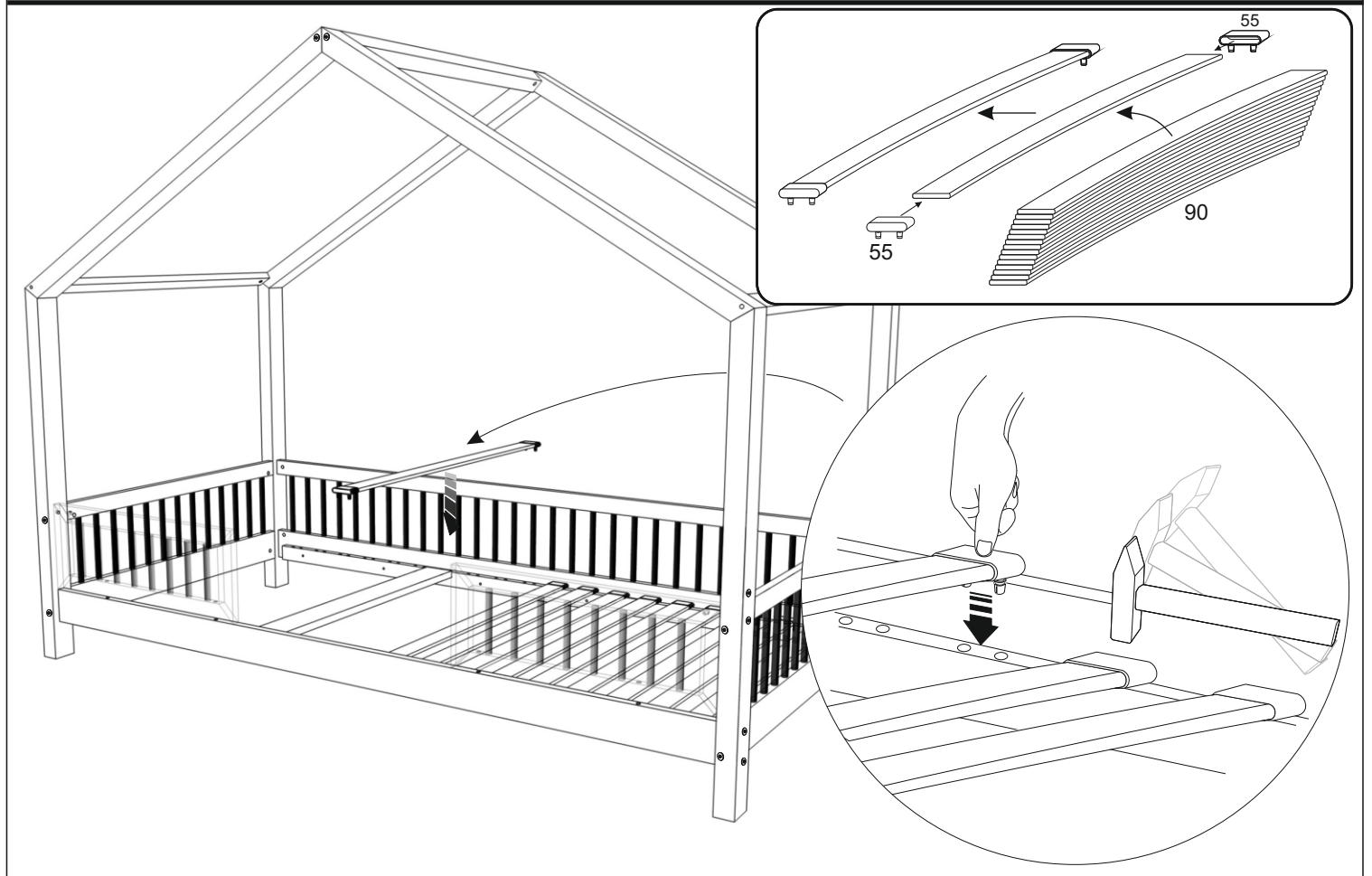
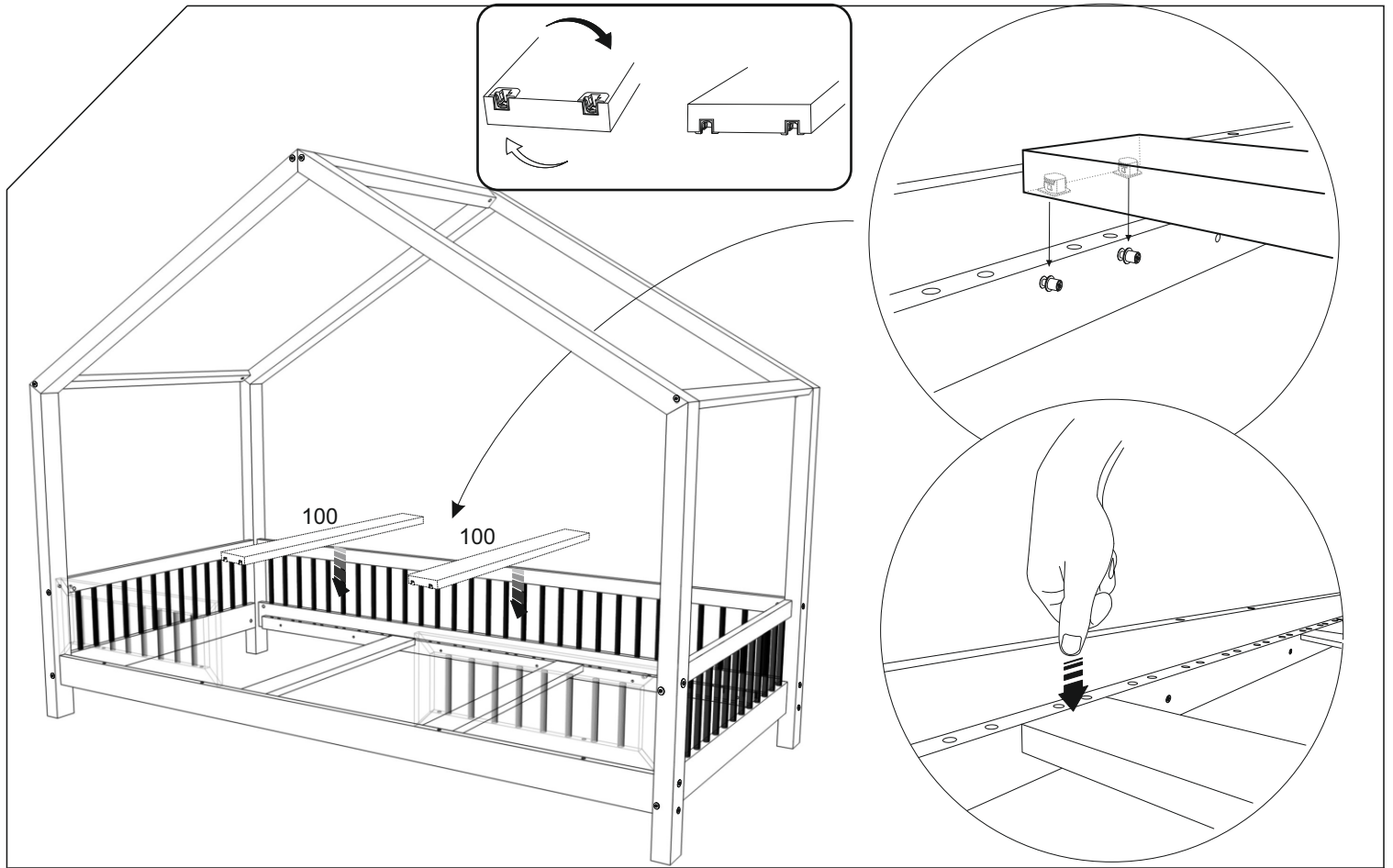

PLASTIC

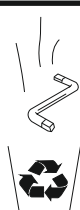

METAL



PAPER

# Drawer assembly instructions

2-5

**A**

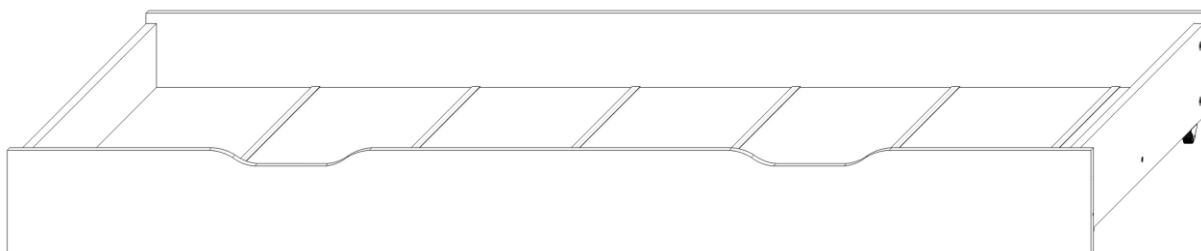

6-9



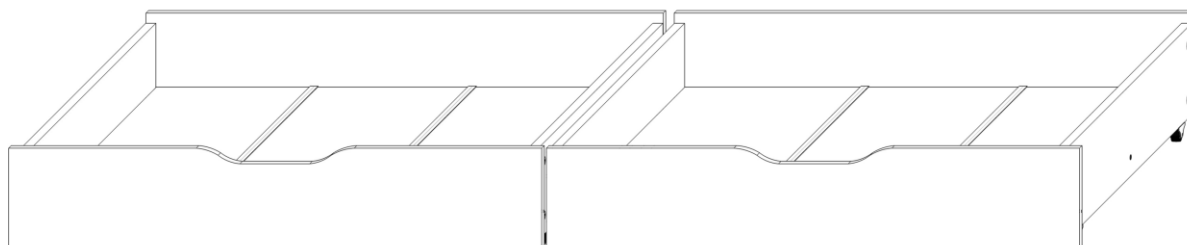



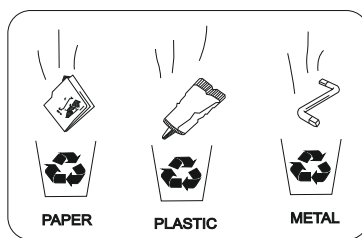
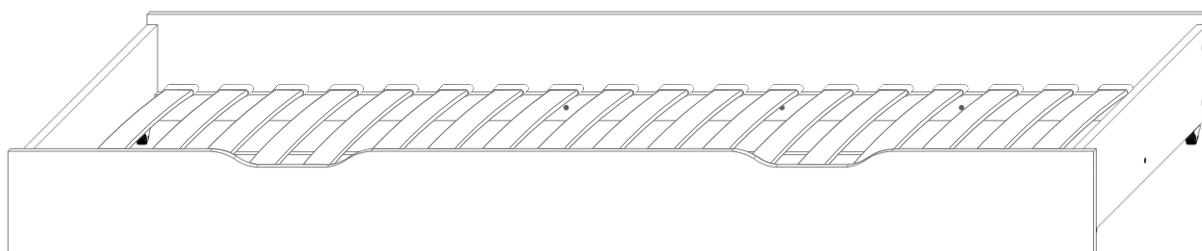

**B**

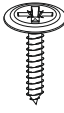
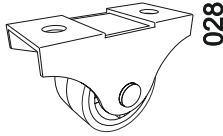

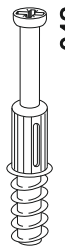
10-12

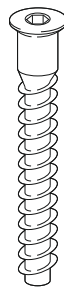
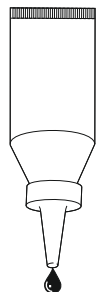
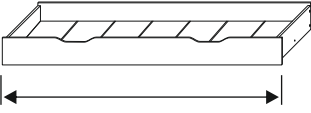
**C**

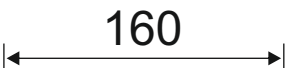
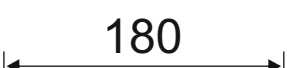

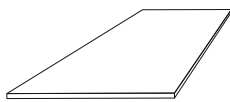
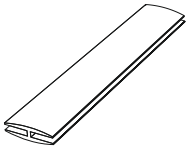
<b>A</b> <b>2</b>  <b>030</b> <b>8x</b>  <b>016</b> <b>8x</b>  <b>028</b> <b>4x</b>  <b>002</b> <b>1x</b>  <b>042</b> <b>8x</b>  <b>015</b> <b>8x</b>  <b>070</b> <b>2x</b>  <b>001</b> <b>1x</b>	  <b>140</b>  <b>160</b>  <b>180</b>  <b>190</b>  <b>200</b>	<b>152</b>  <b>5x</b> <b>6x</b> <b>6x</b> <b>7x</b> <b>7x</b>	<b>153</b>  <b>4x</b> <b>5x</b> <b>5x</b> <b>6x</b> <b>6x</b>
---	---	--	--

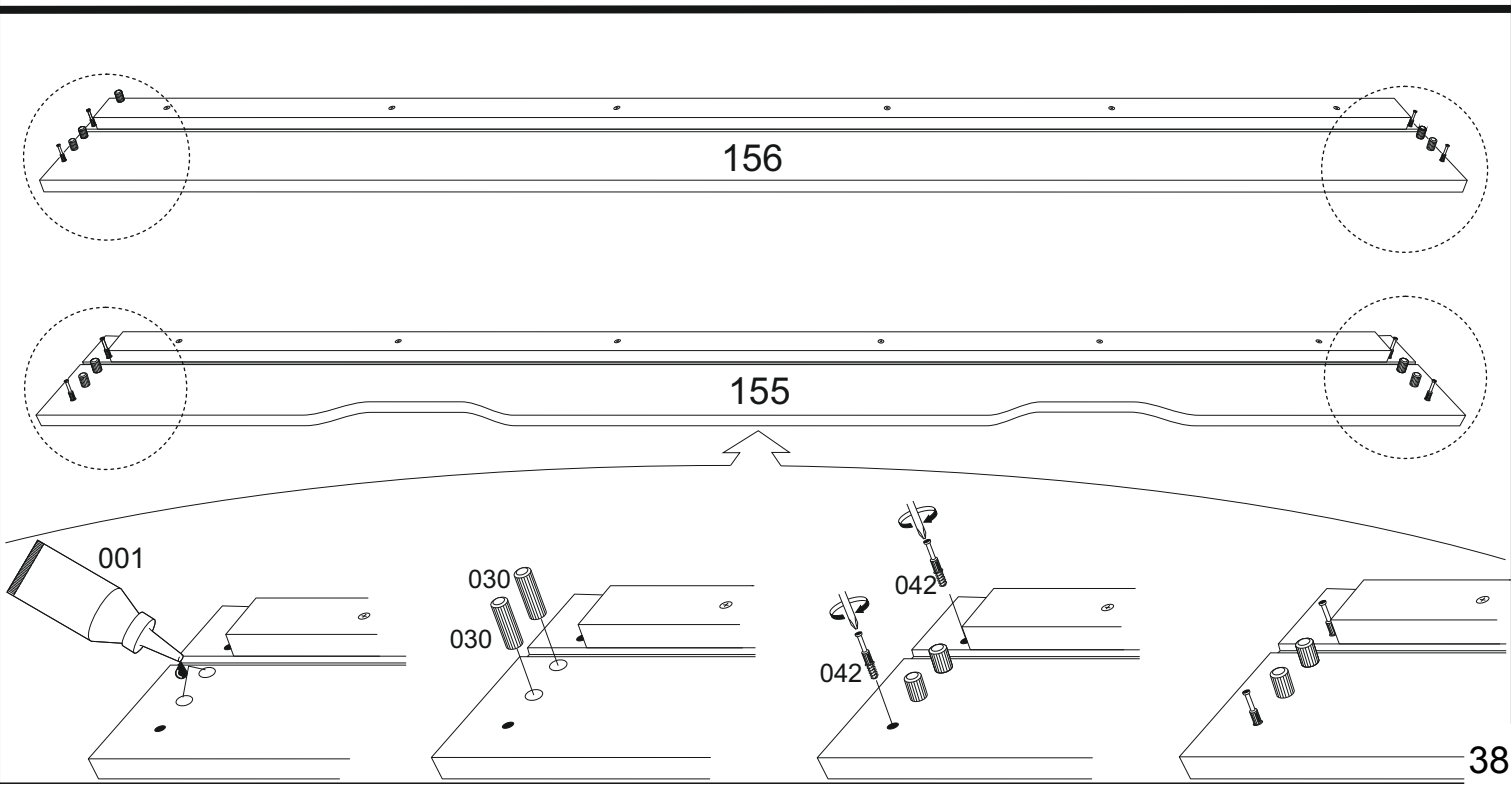
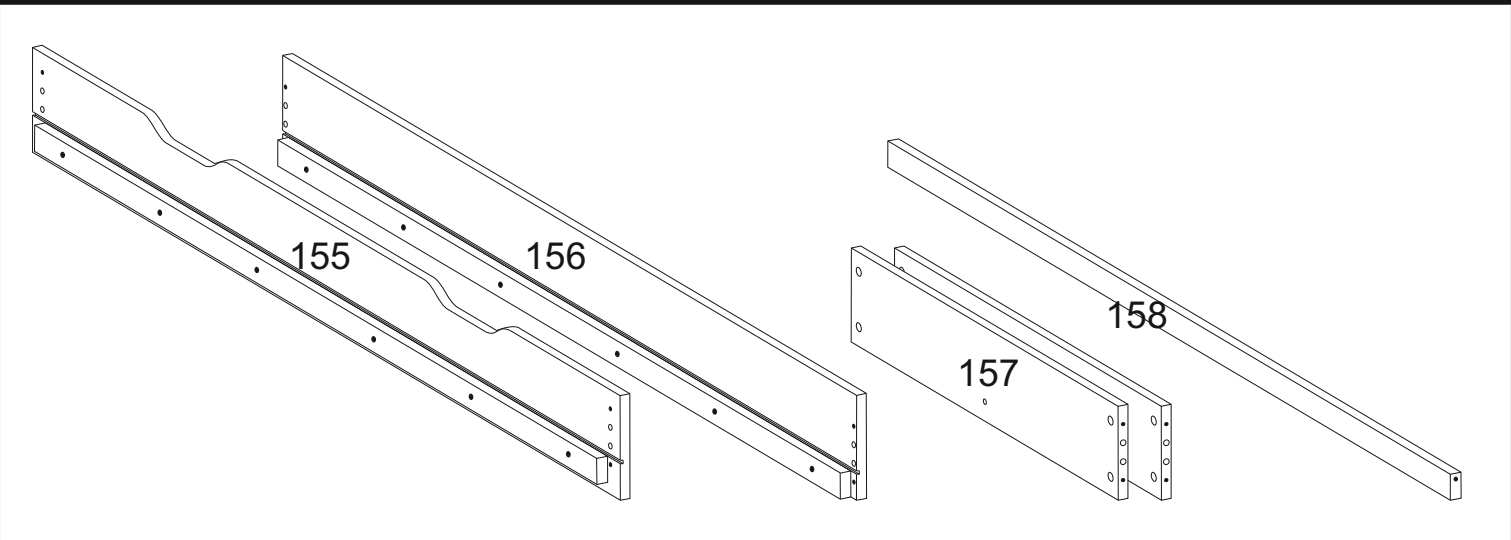

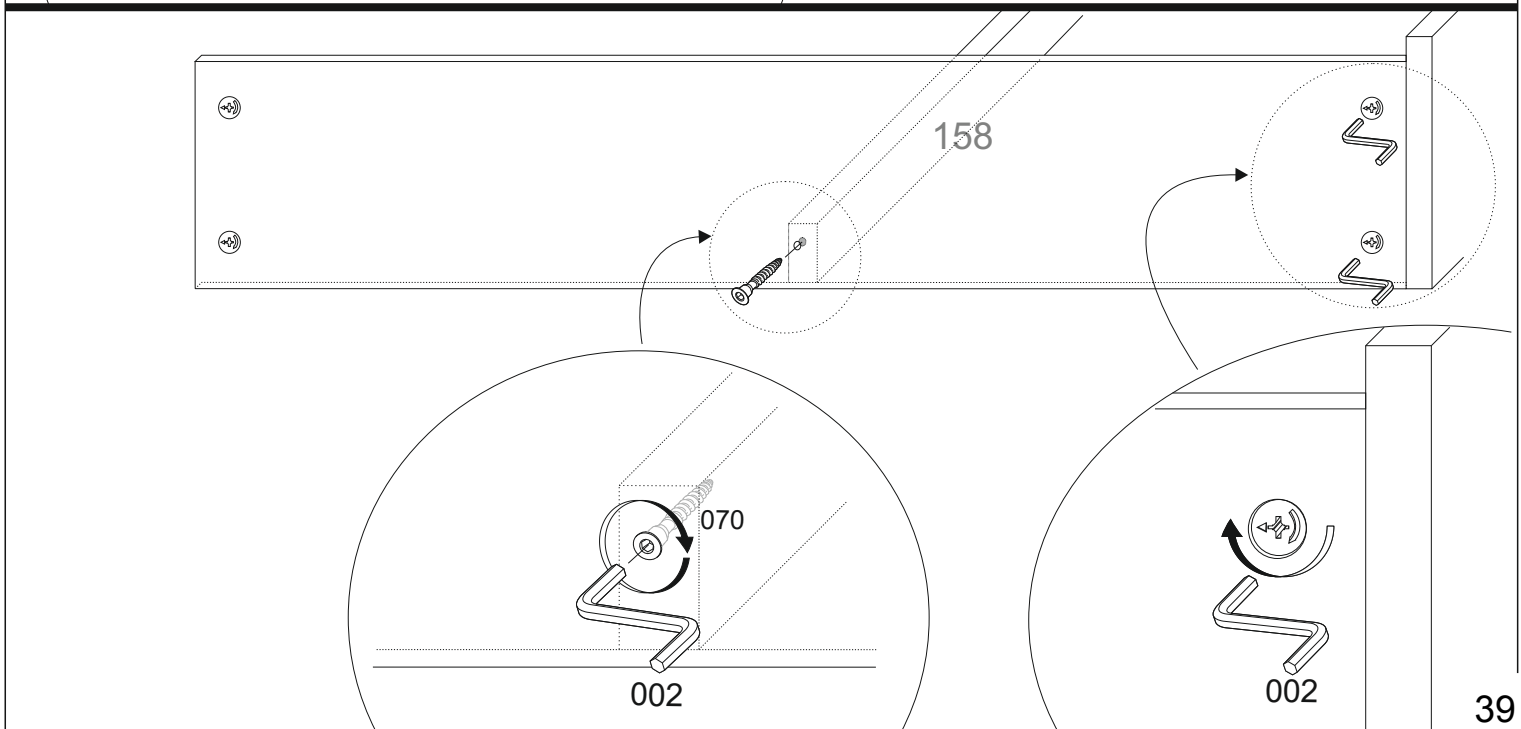
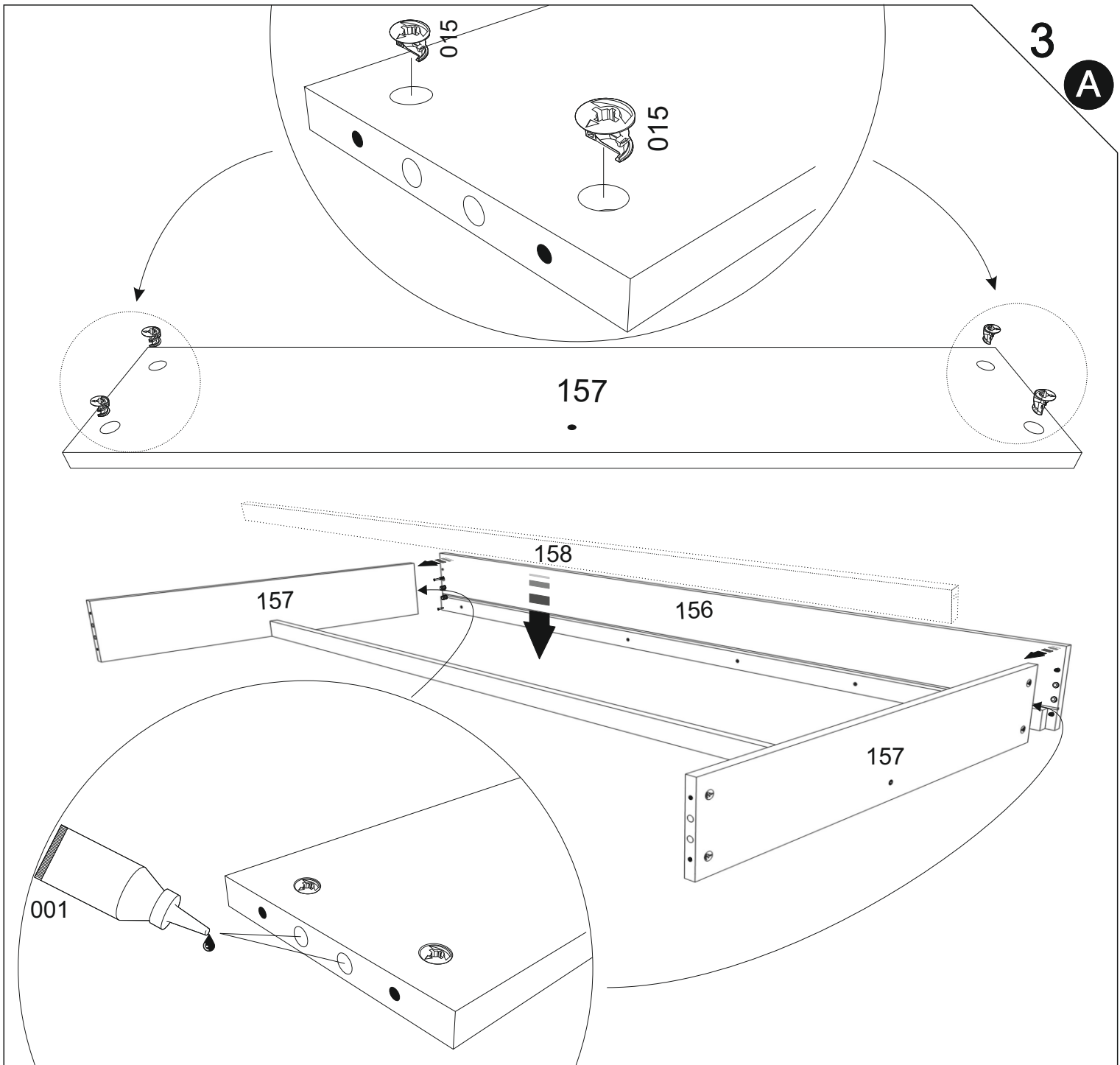

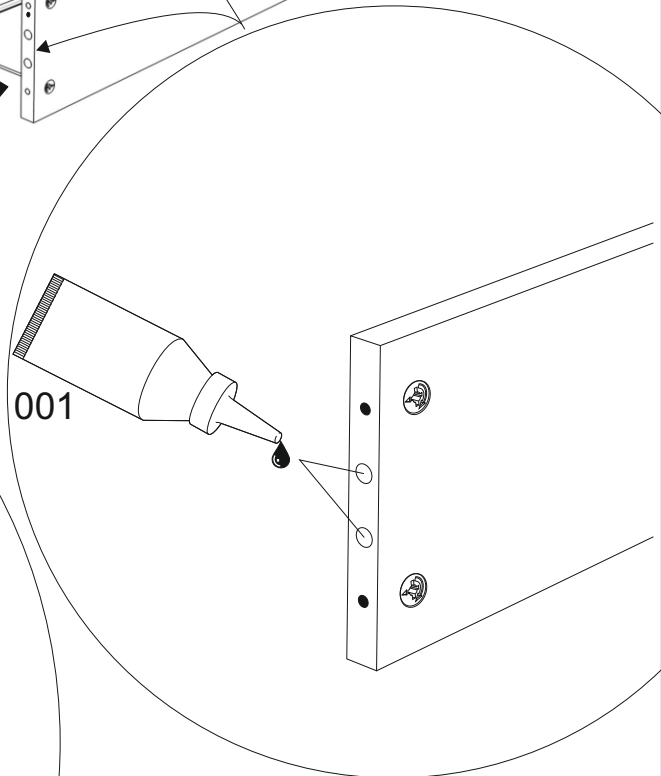
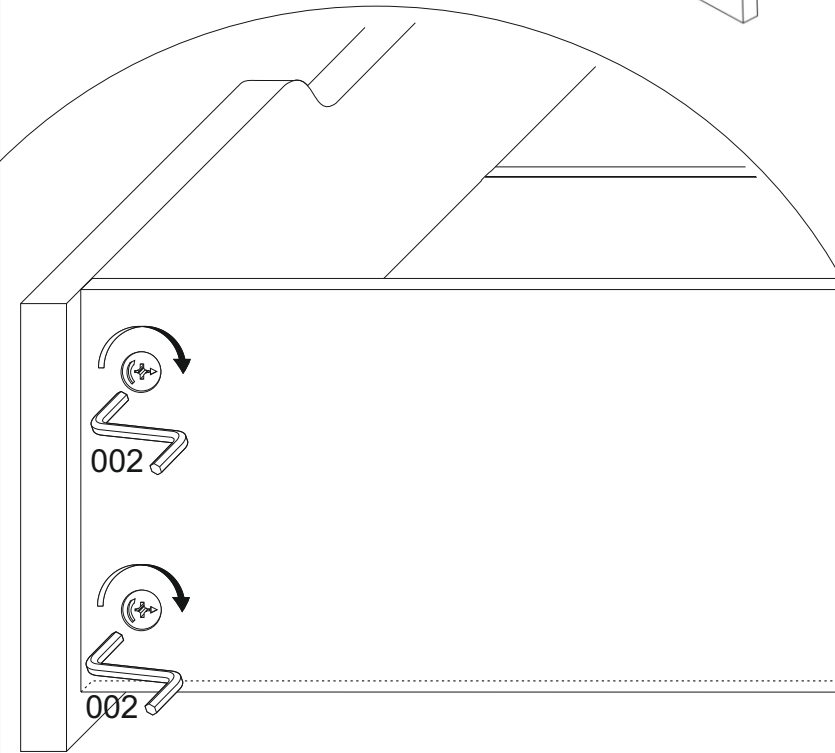
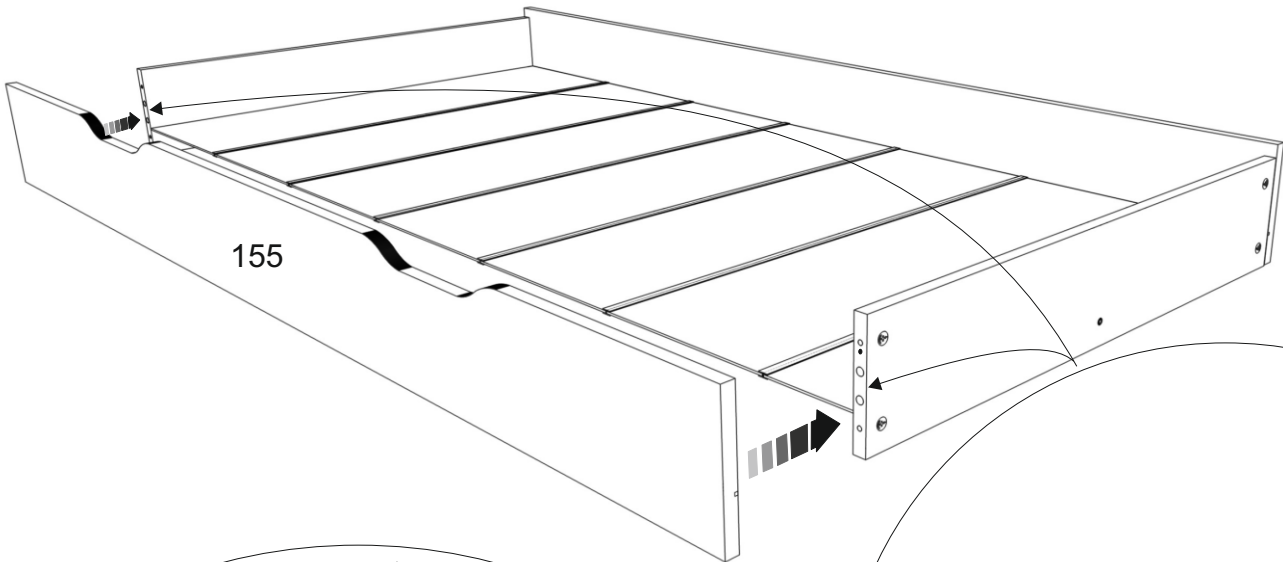
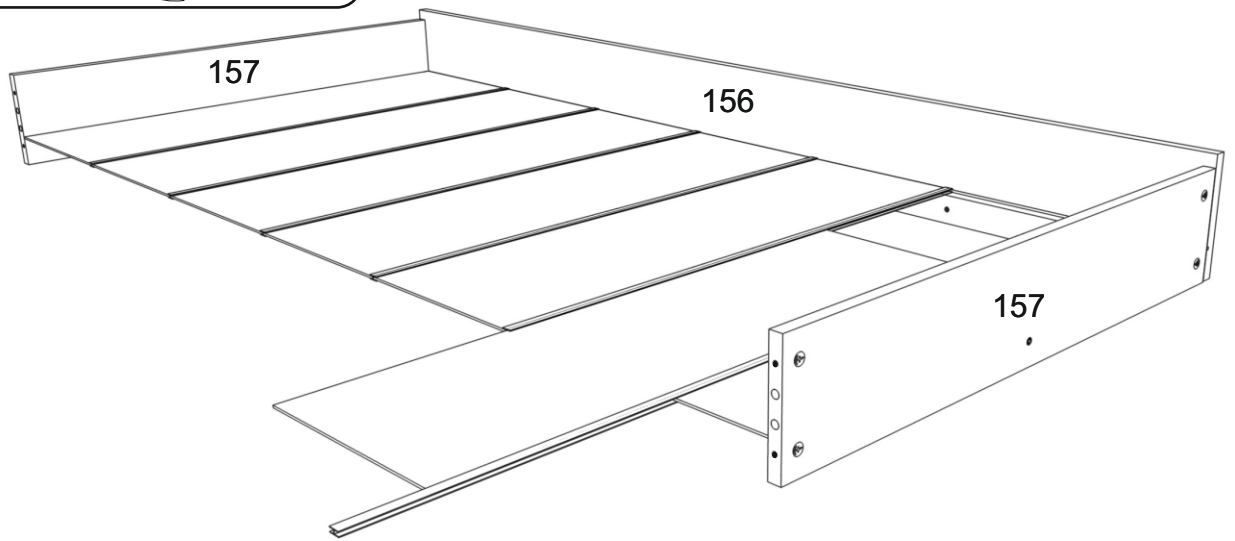
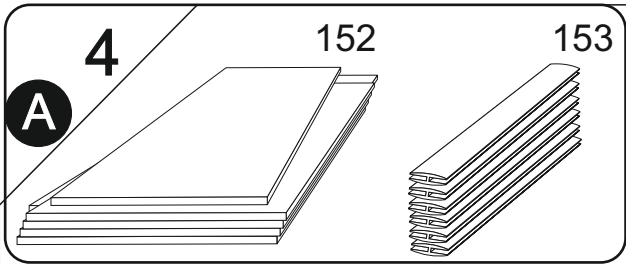



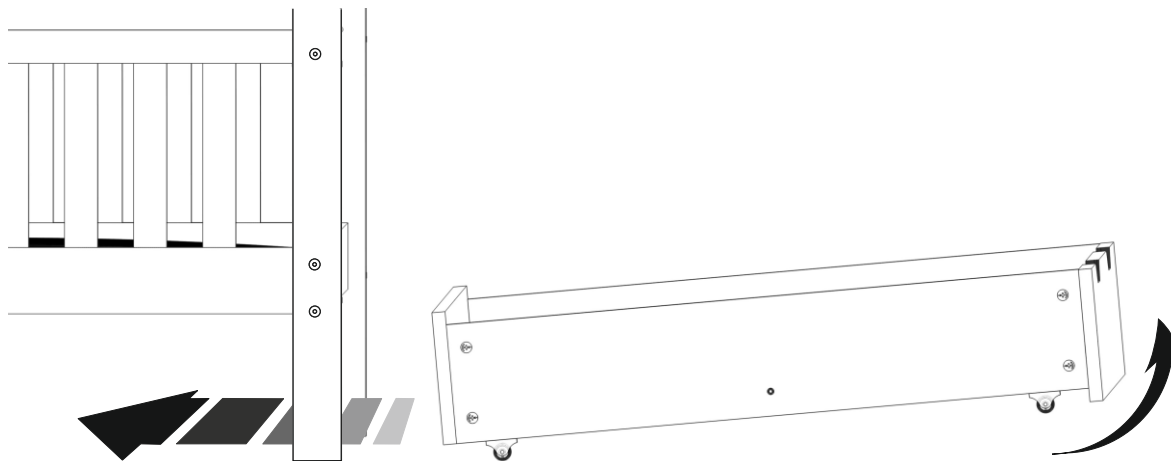
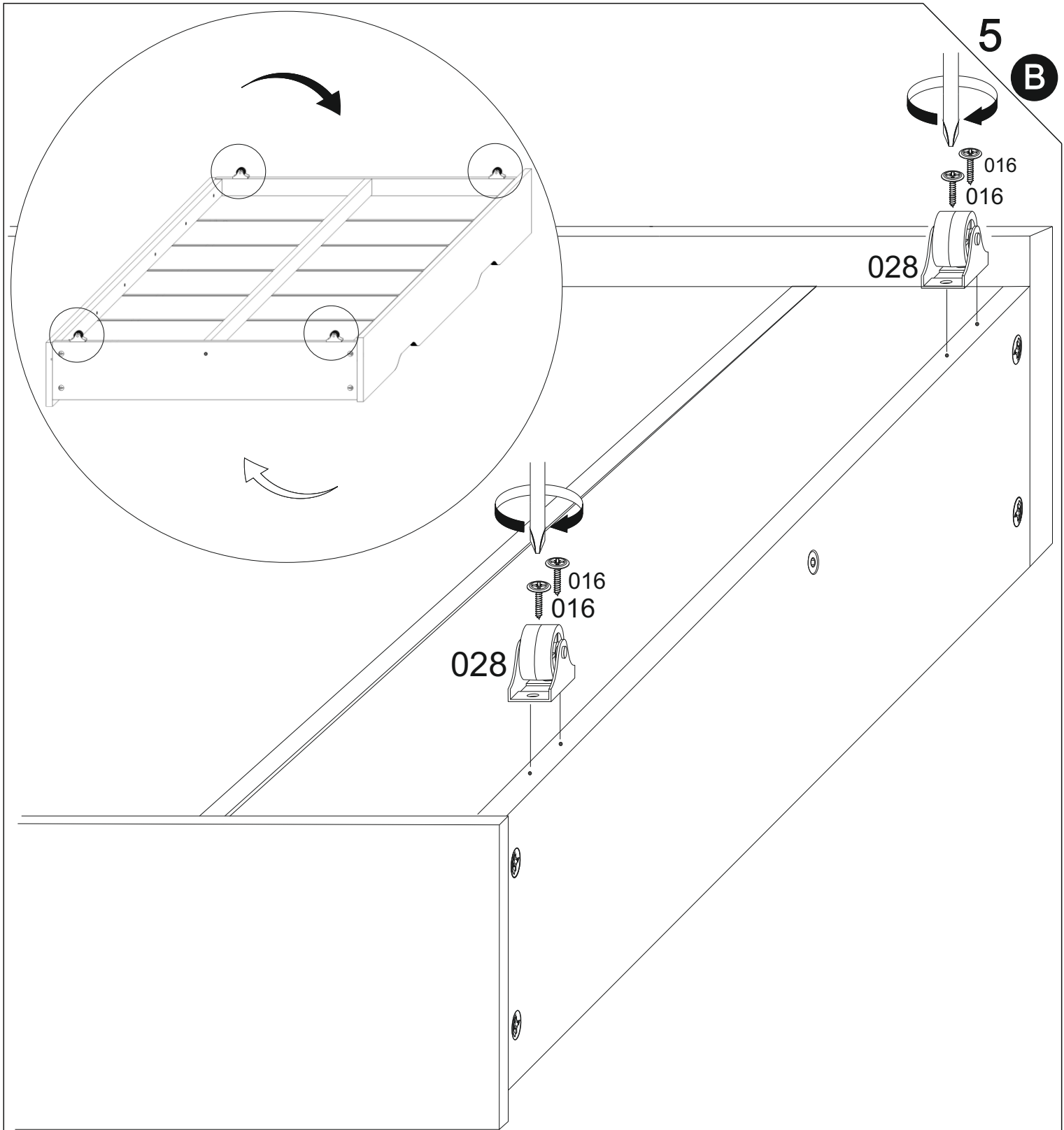

**B** 6

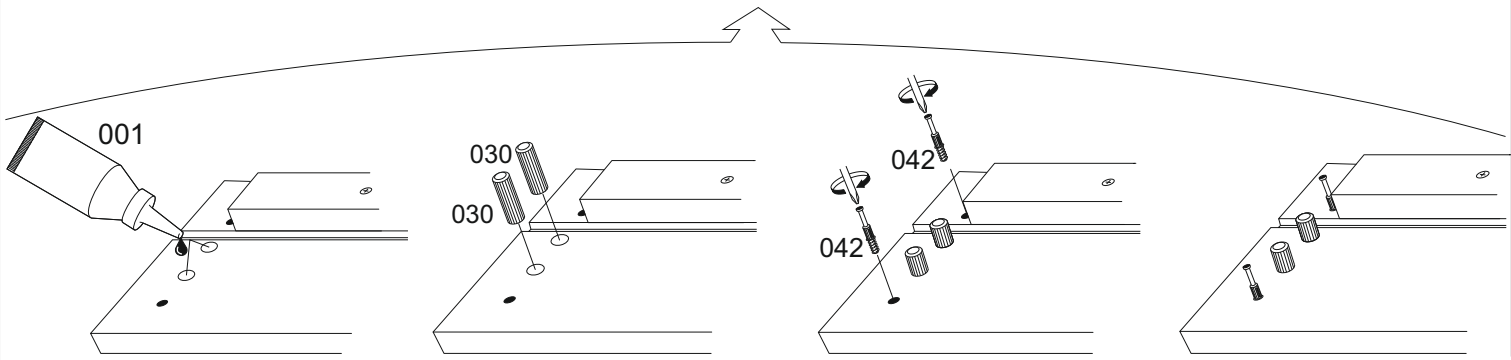
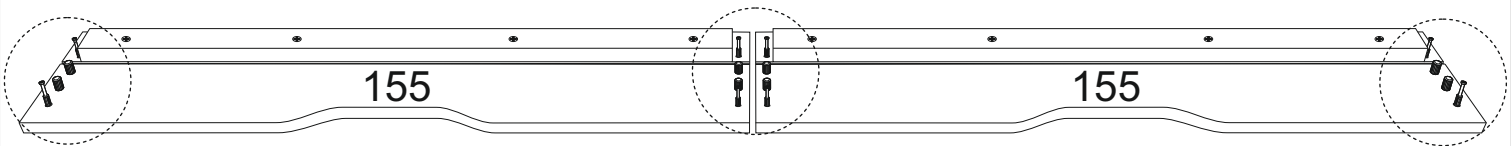
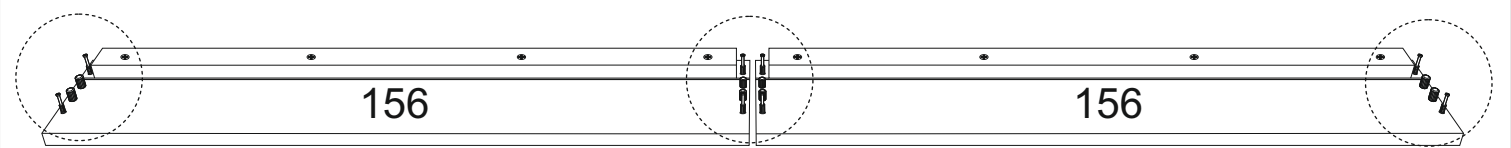
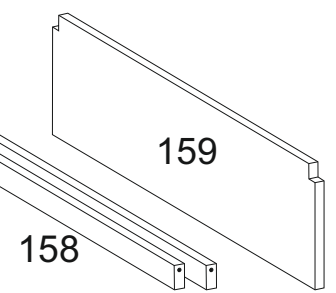
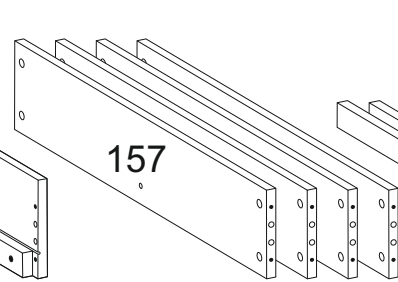
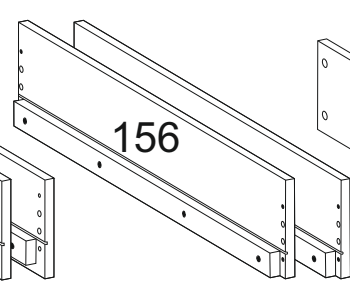
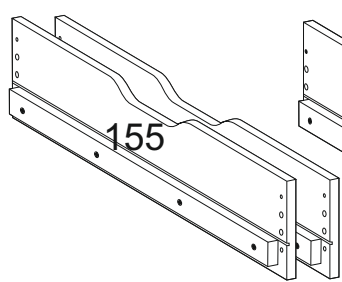
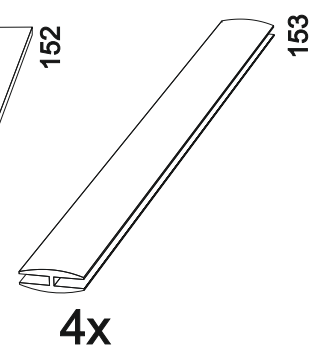
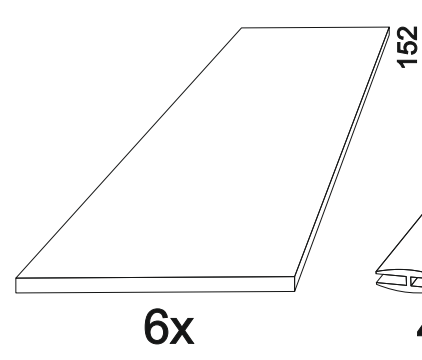
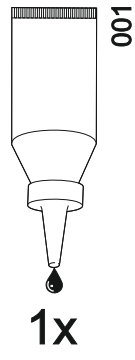
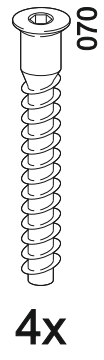
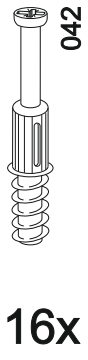
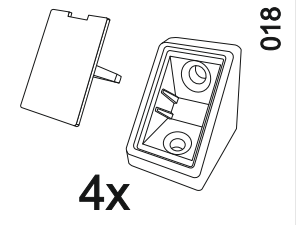
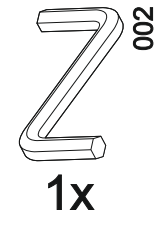
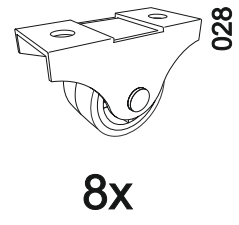
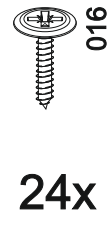
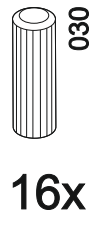

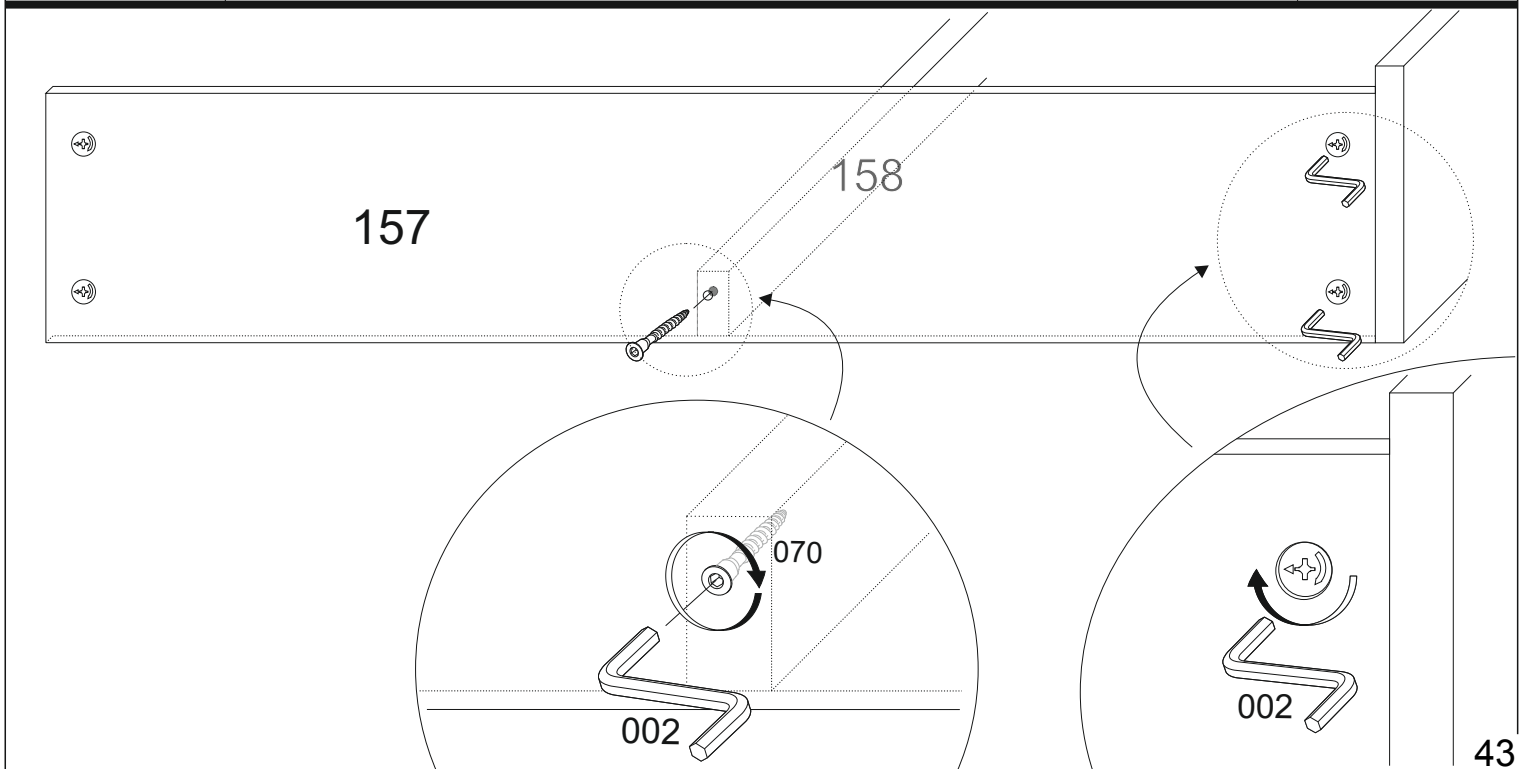
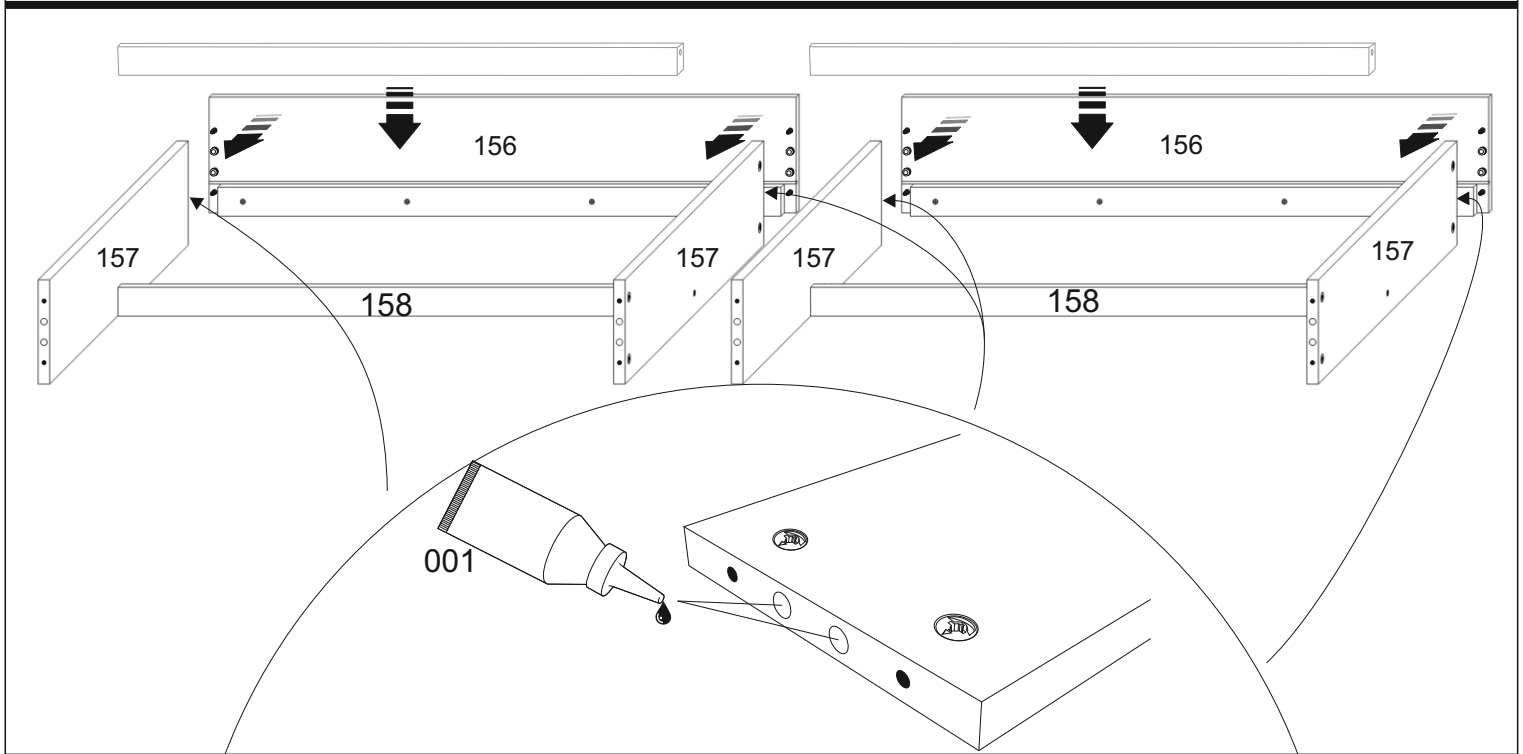
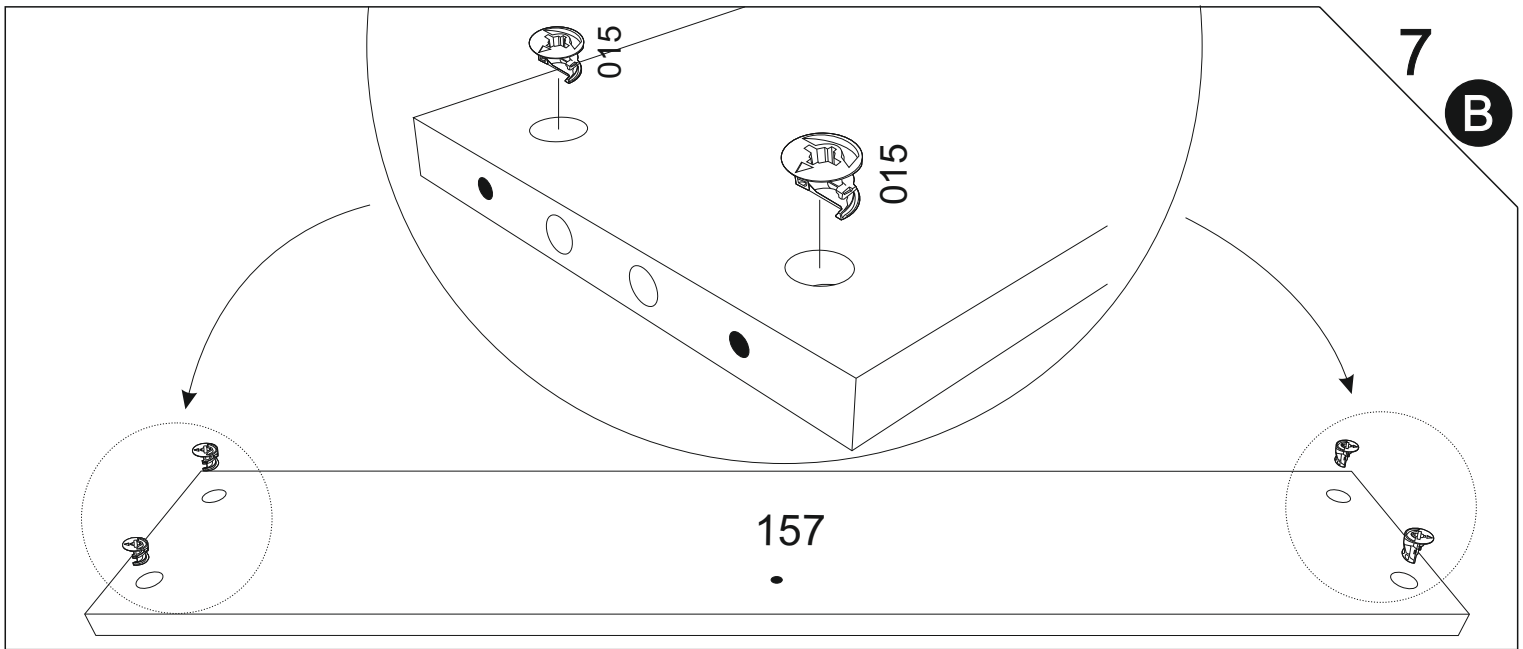

**B** 8

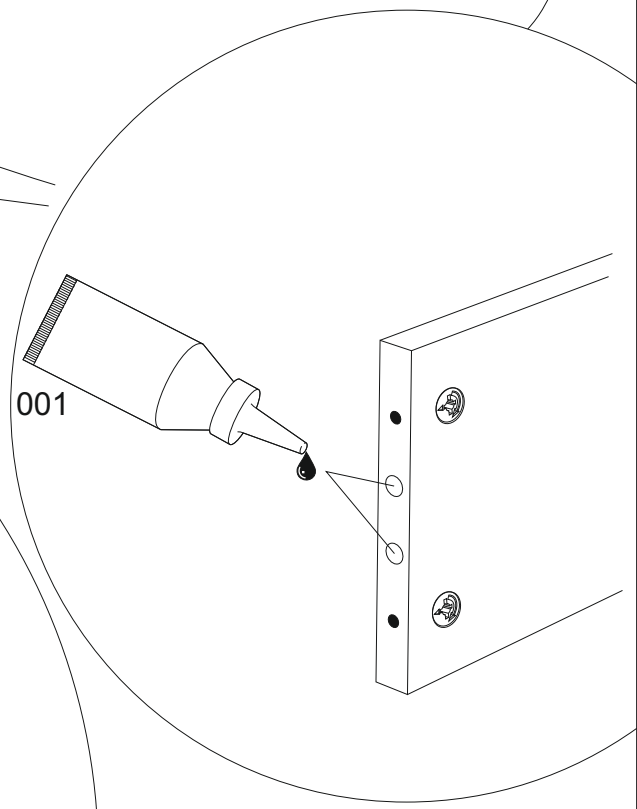
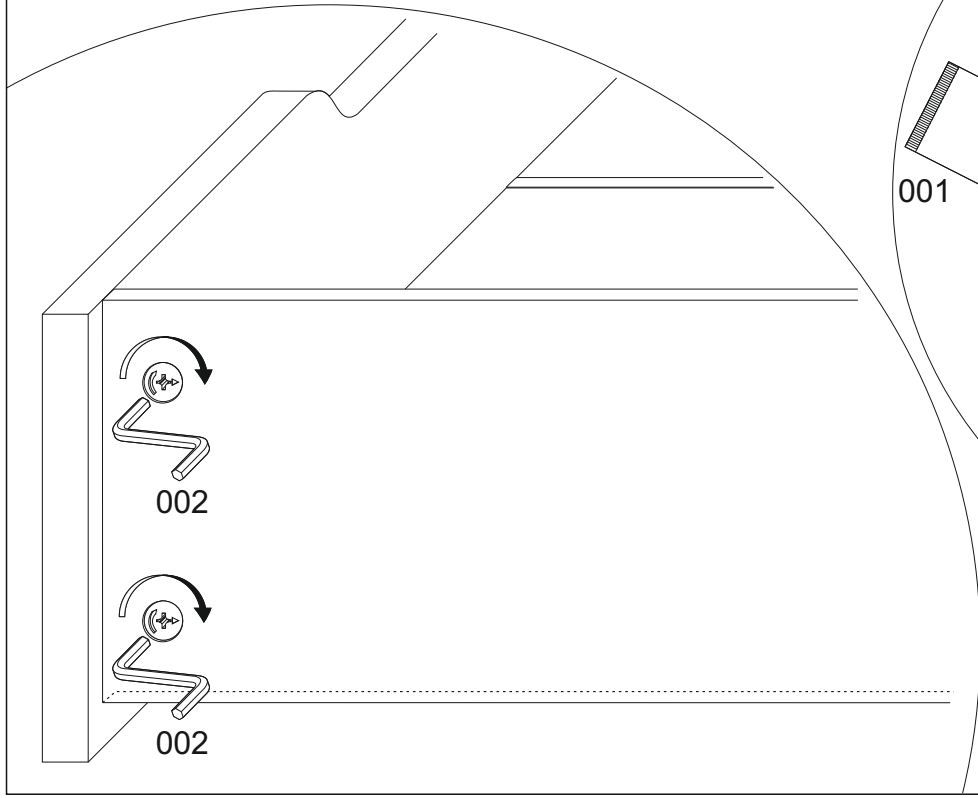
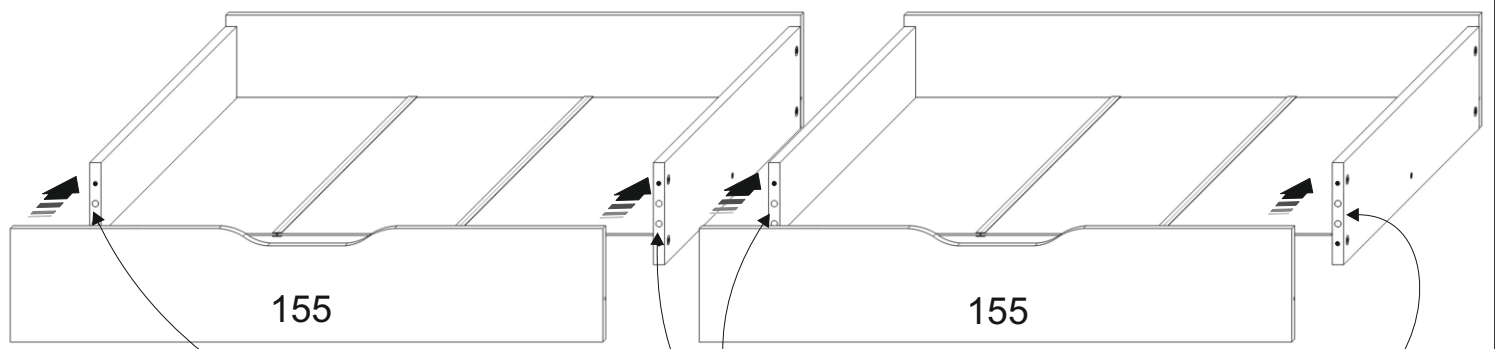
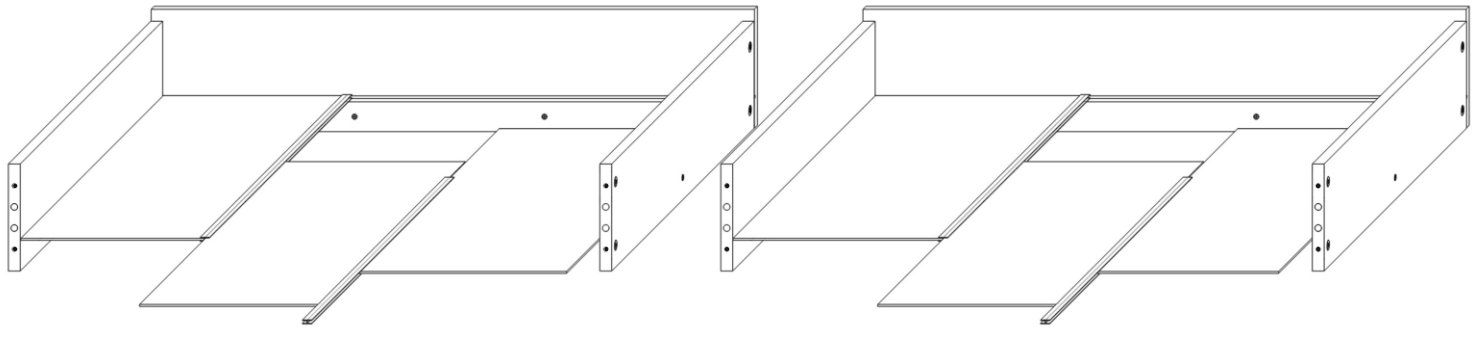
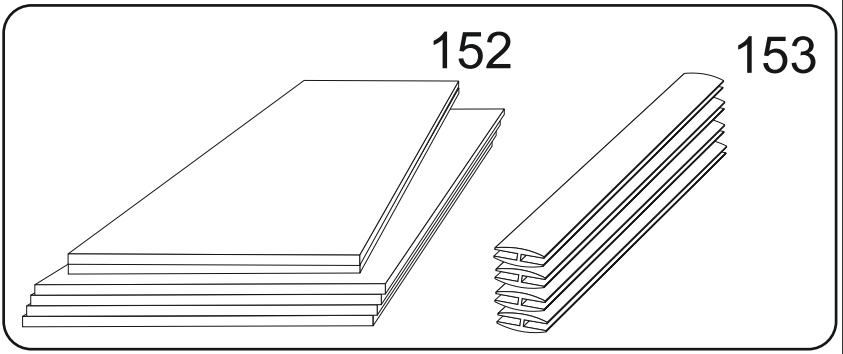

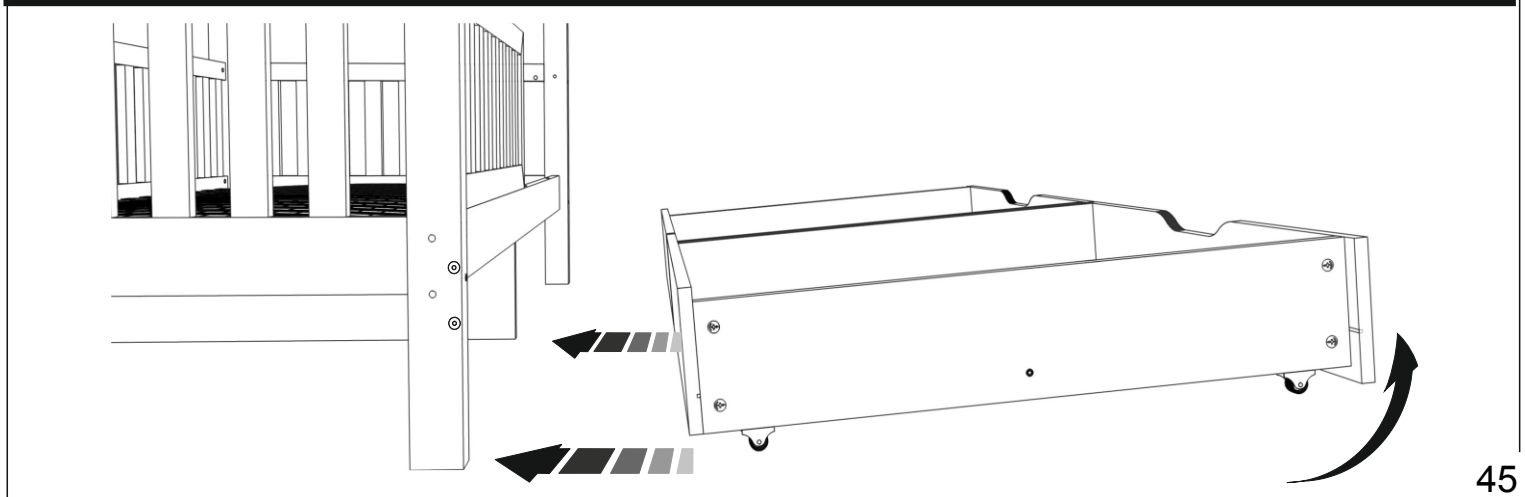
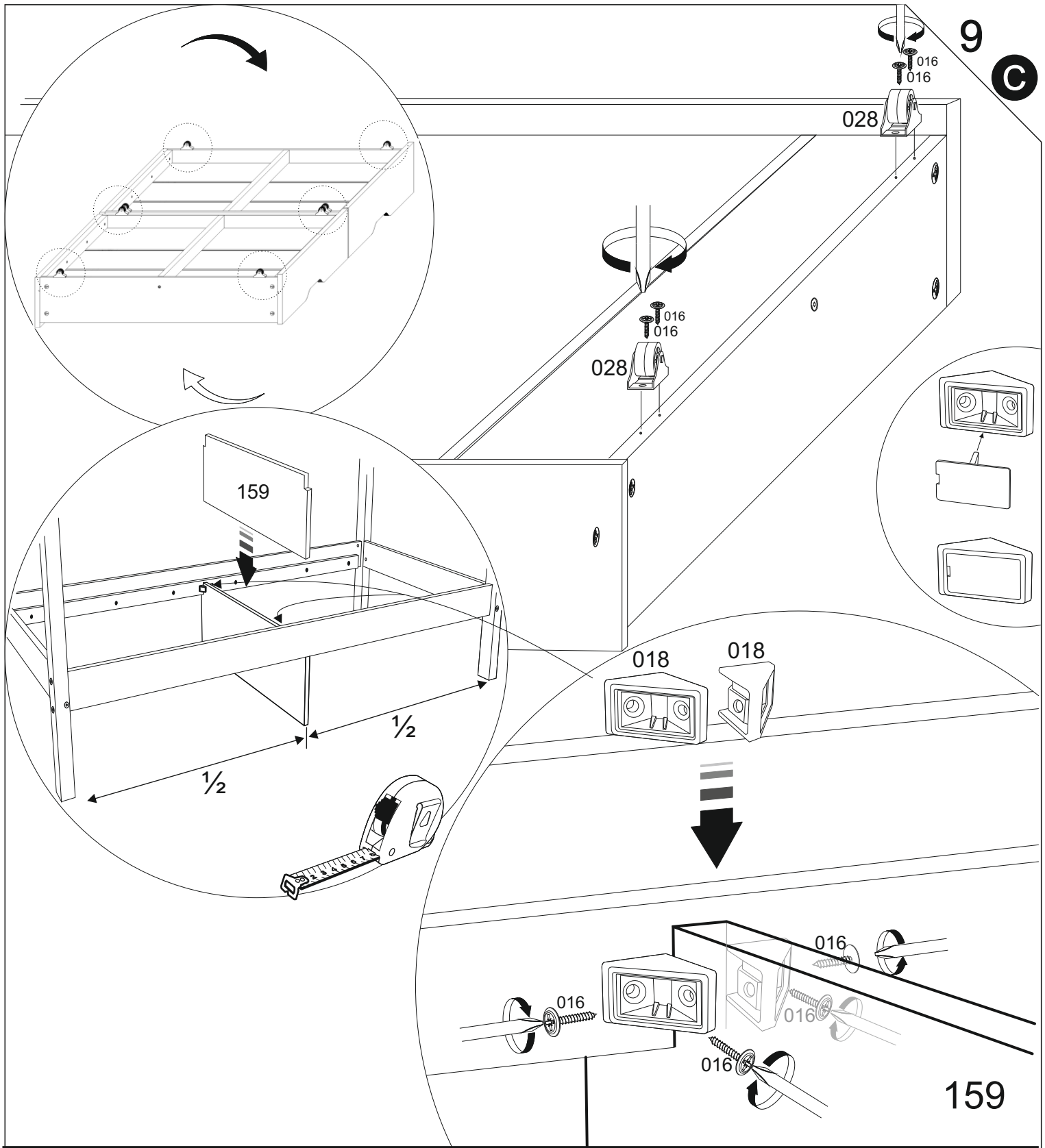

**C** 10

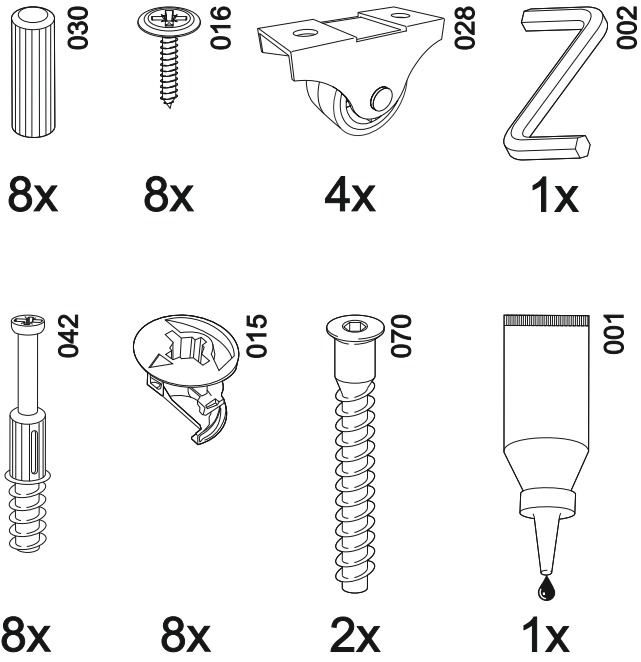

	055		090
← 140 →	28x	← 140 →	14x
← 160 →	32x	← 160 →	16x
← 180 →	36x	← 180 →	18x
← 190 →	38x	← 190 →	19x
← 200 →	40x	← 200 →	20x

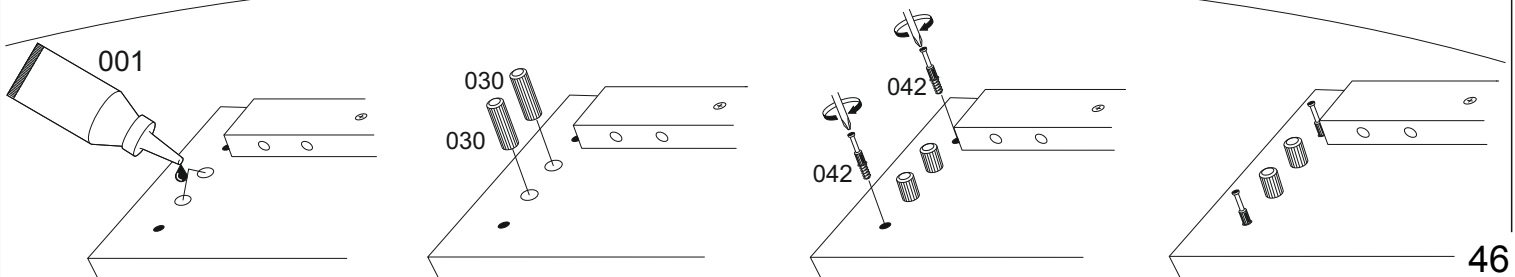
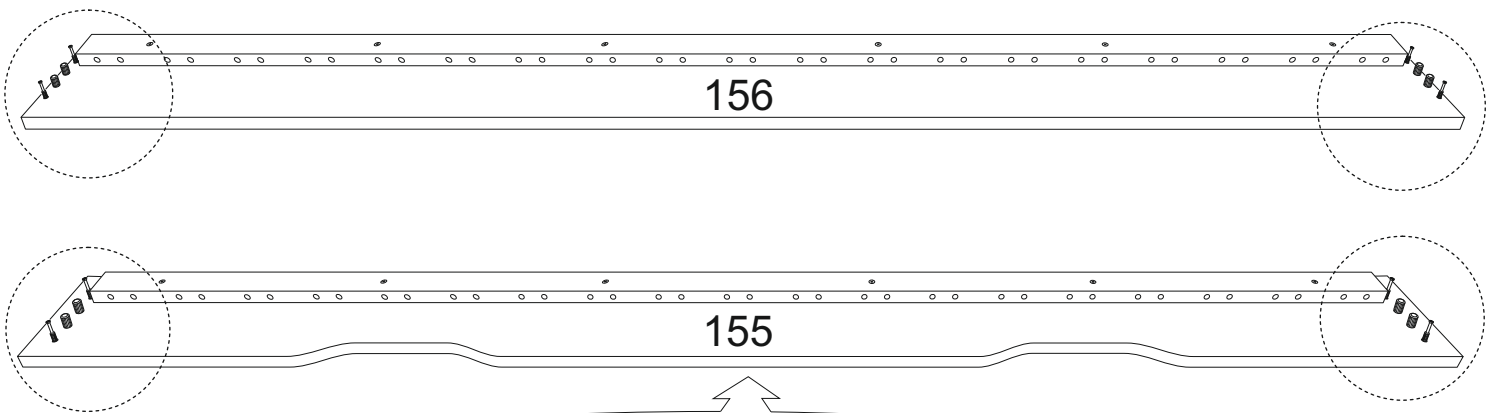
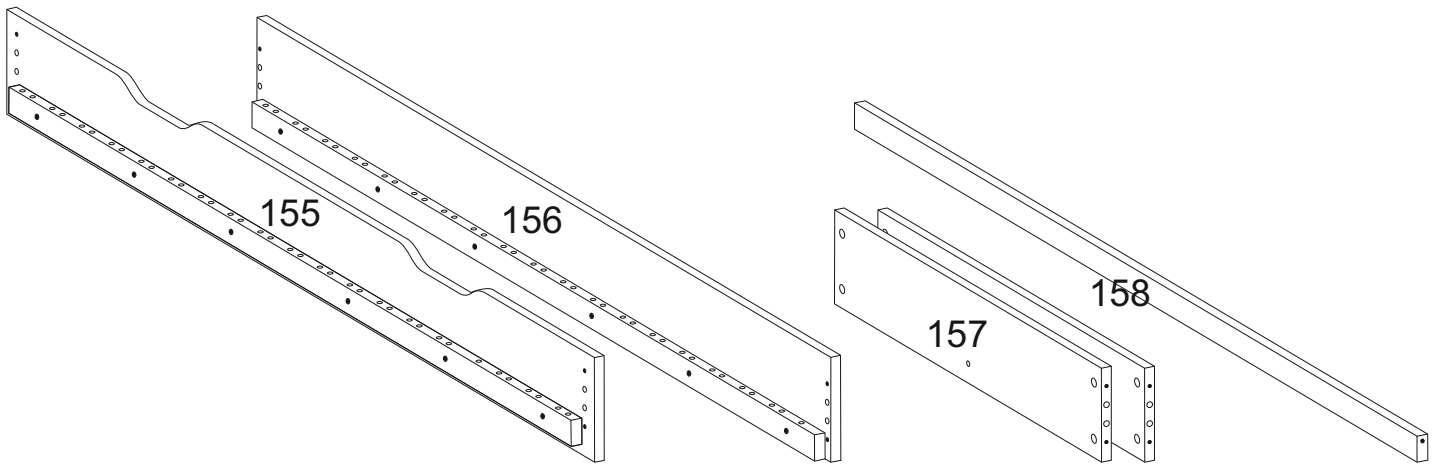

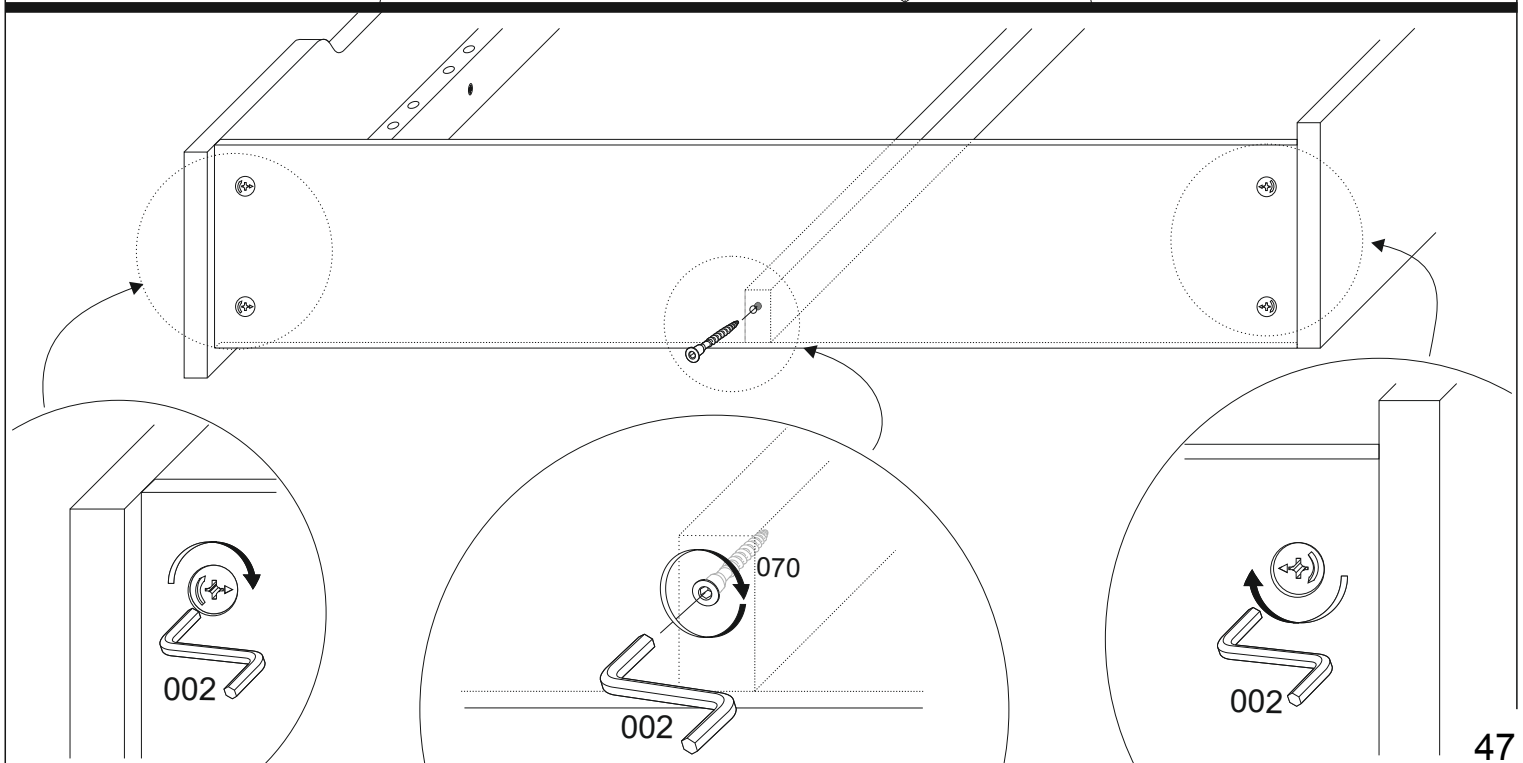
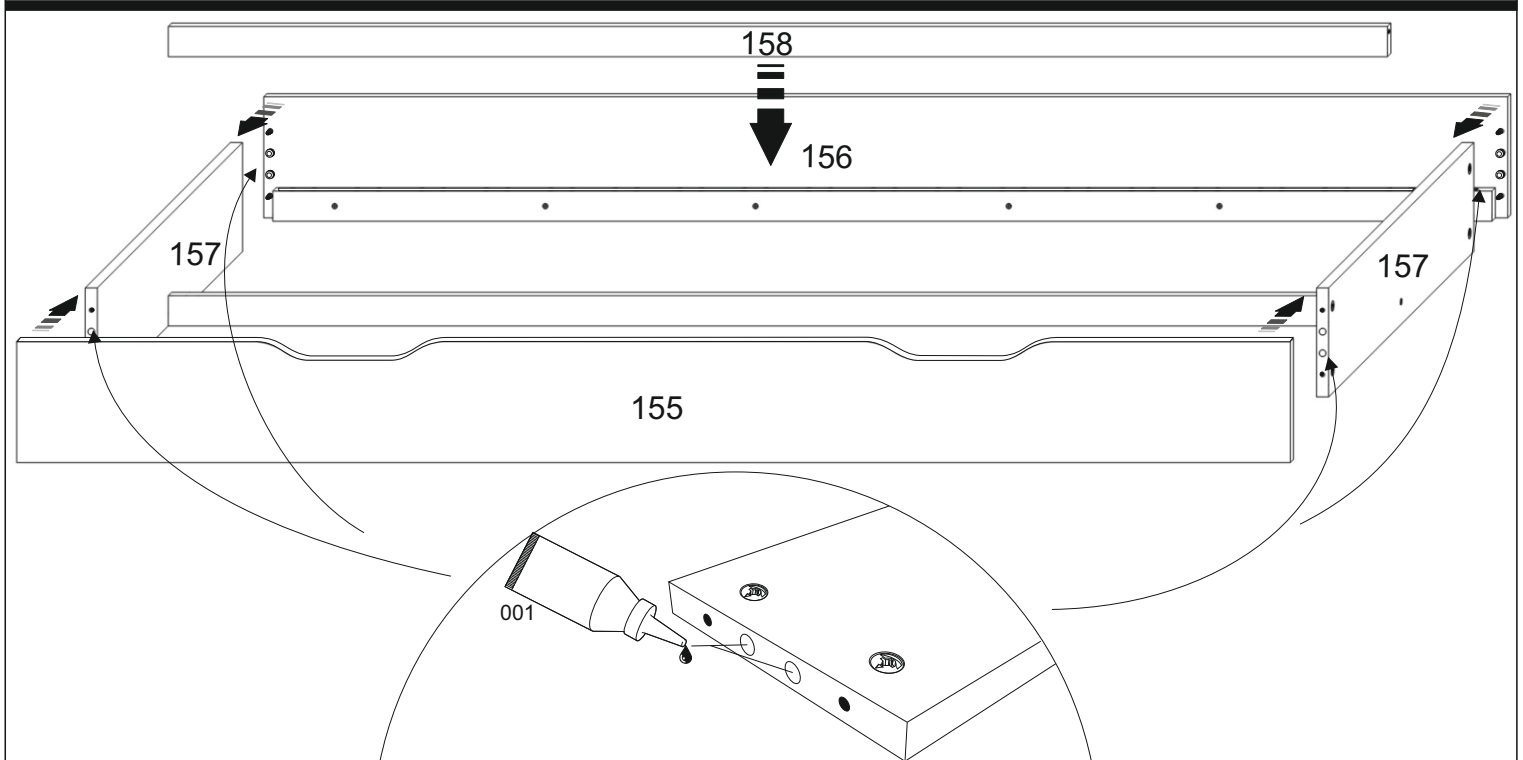
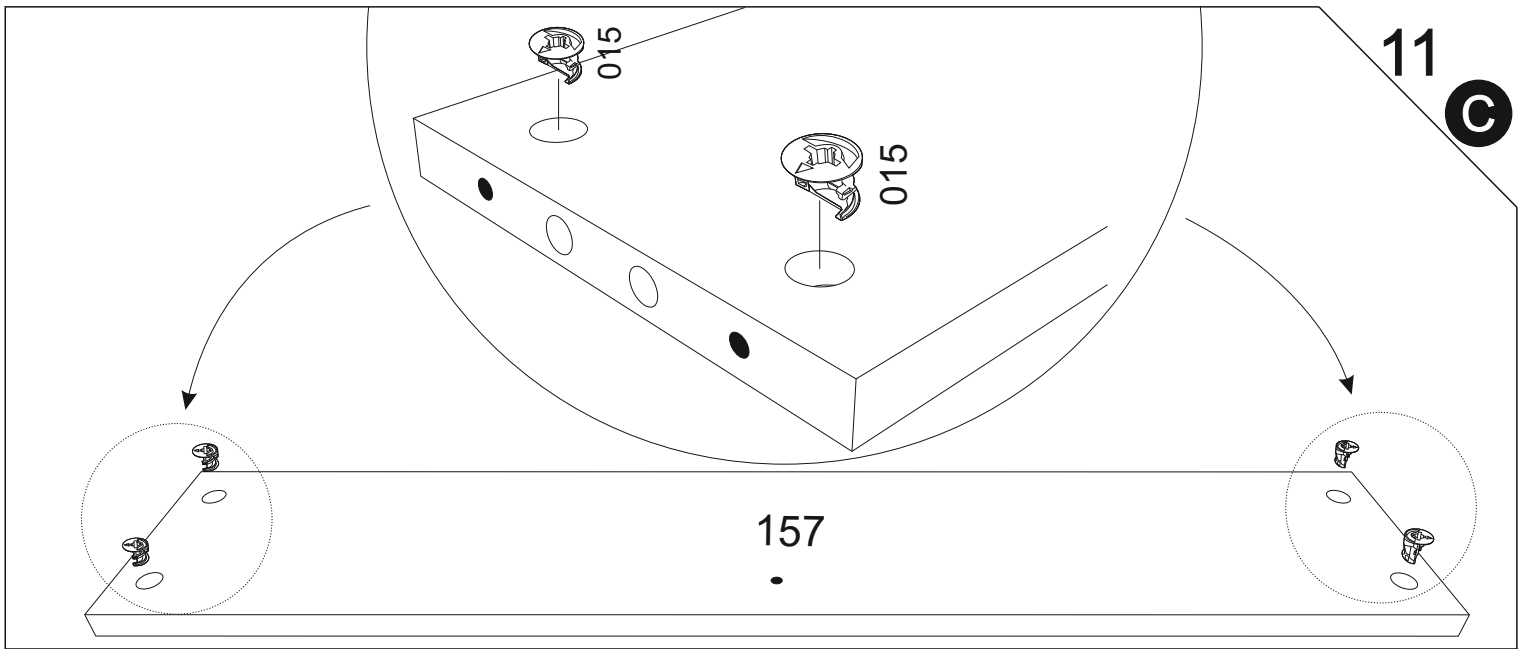

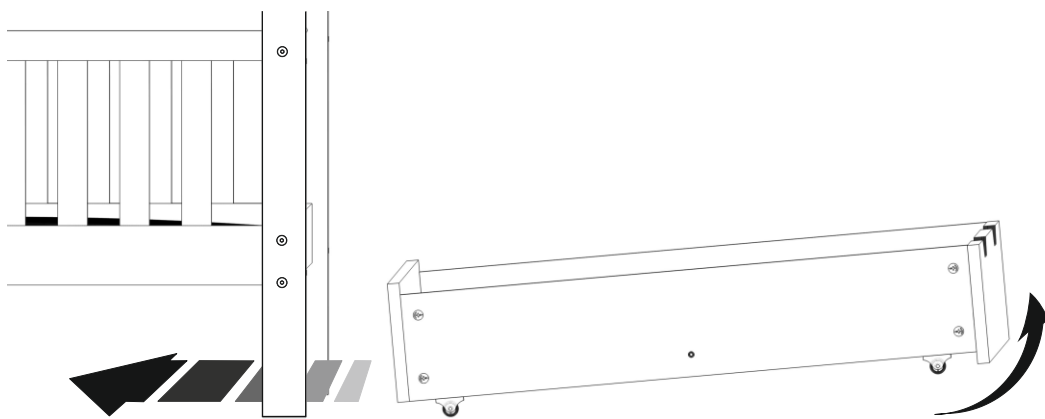
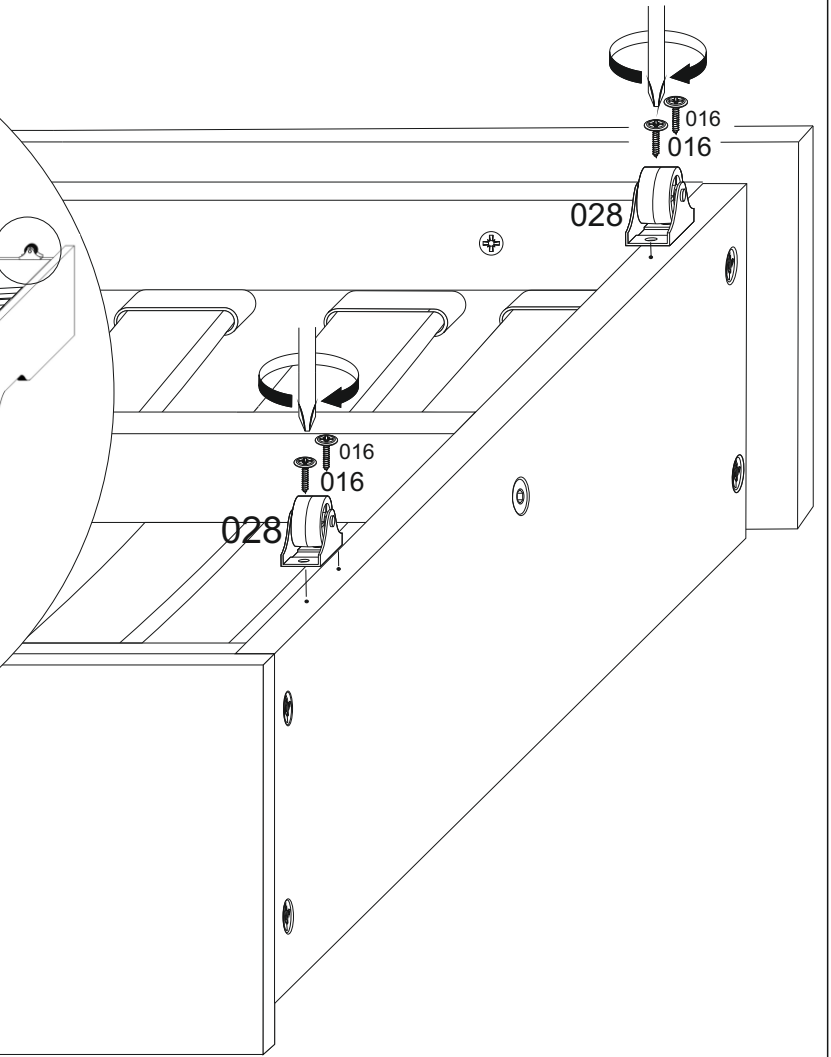
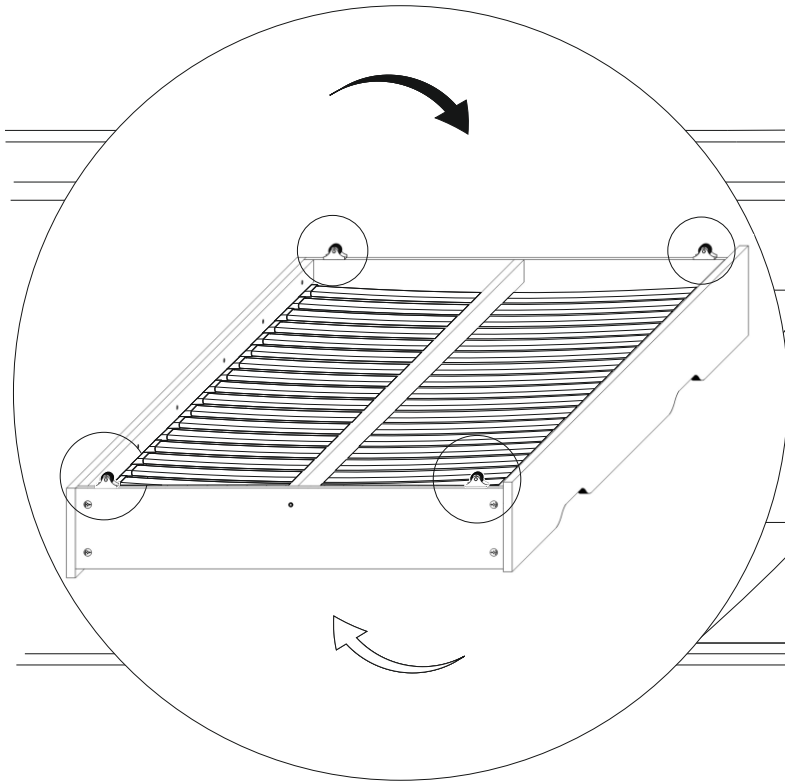
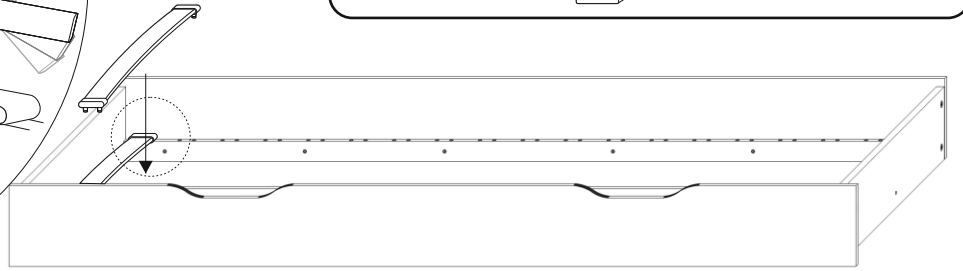
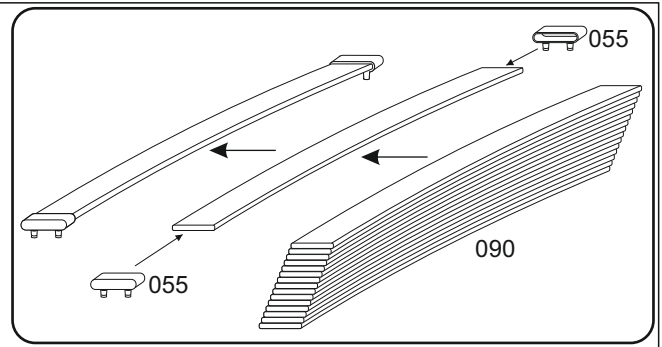
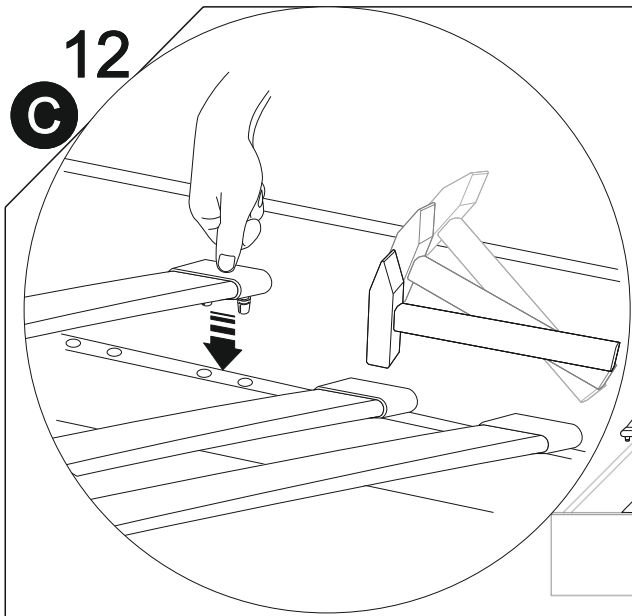



## Woohoo!

High-fives all around for a job well done.

We hope your little one is over the moon with their new Petit Puk bed. And why not show off all your hard work? Snap a pic and share it with us on Instagram (tag us @petitpuk) or shoot us an email at [info@petitpuk.com](mailto:info@petitpuk.com). We love seeing our creations come to life in your wonderful homes!

Now, before your kid dives in headfirst, here are a few friendly reminders:

- Stick to mattresses between 8-14 cm thick for the perfect fit.
- Beds are for snoozing, not bouncing
- Keep it safe with just one child on the bunk bed.
- Please, no acrobatics - avoid hanging off any parts of the bed.
- Keep things tidy with a gentle wipe-down of wooden and plastic parts using a dry cloth and mild cleaner.

### **Warranty**

We've got your back with a 2-year warranty on bed parts under normal use. If you ever need a hand or have any questions, don't hesitate to reach out to Team Petit Puk. Just send us a message with your name and order number, along with images of the situation.