

Assembly Manual **PETIT PUK** for **PEPE SLIDE BED**



Congratulations with your PETIT PUK BED!

Now it's assembly time. Please make sure to check these elements prior to starting:

- ♥ is everything complete?
- ♥ are all pieces in good shape?
- ♥ good spirits and perhaps a partner in crime in your presence?
- ♥ ready to take a photo of your great work afterwards, to share it with us?
- ♥ ticked all boxes with yes? Ready, steady, gooo!

PS. A tip

You will find small green glue tubes with EU standards. Just slide a small amount of glue into the holes to receive the wood dowels. Glue is only necessary at the level of beveled wood stud assemblies for perfect stability. It is not necessary to put glue on the bed base which would prevent you from dismantling the bed afterwards.





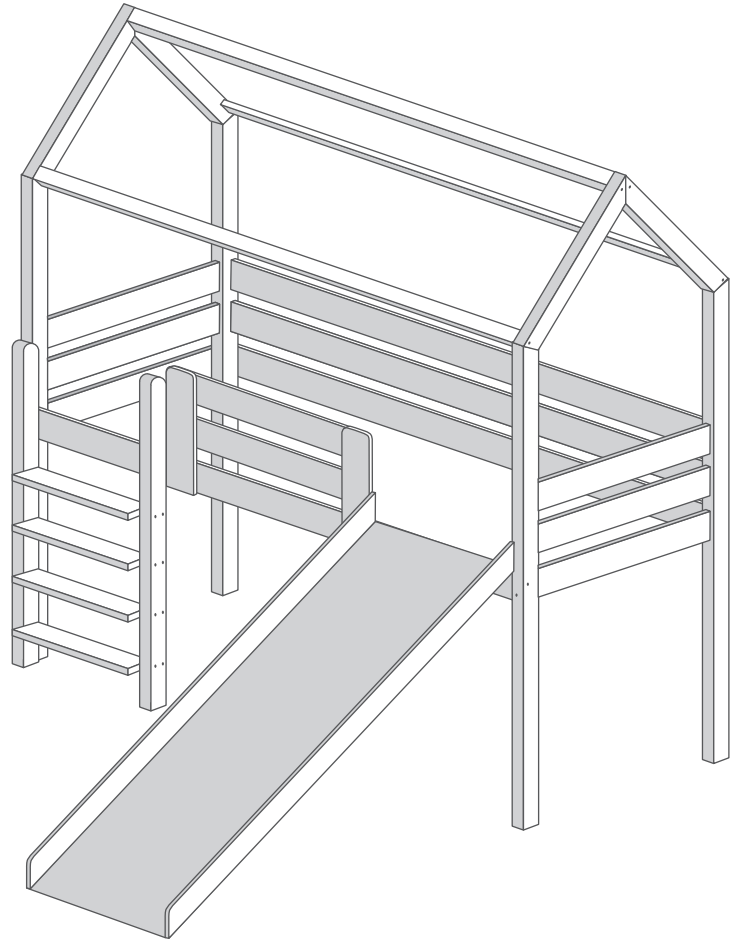

**PETIT
♥ PUK ♥**

www.petitpuk.com f [petitpuk](#)  [petitpuk](#)

PEPE SLIDE BED



user manual:

	<i>glue</i>	3
	<i>wooden pegs</i>	47
	<i>small screws</i>	30
	<i>small screws (imbus) 30mm</i>	16
	<i>small screws (imbus) 55mm</i>	2
	<i>big screws</i>	39
	<i>imbus</i>	2
	<i>beam to be installed instead of the slide</i>	2
	<i>plug</i>	
	<i>cap</i>	34

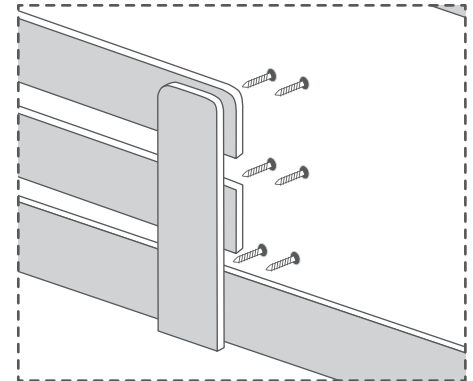
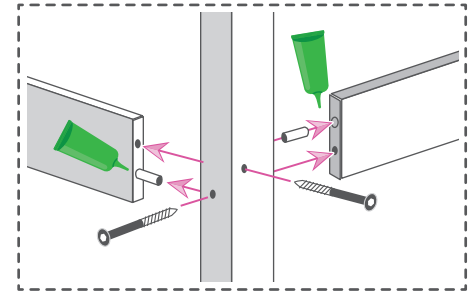
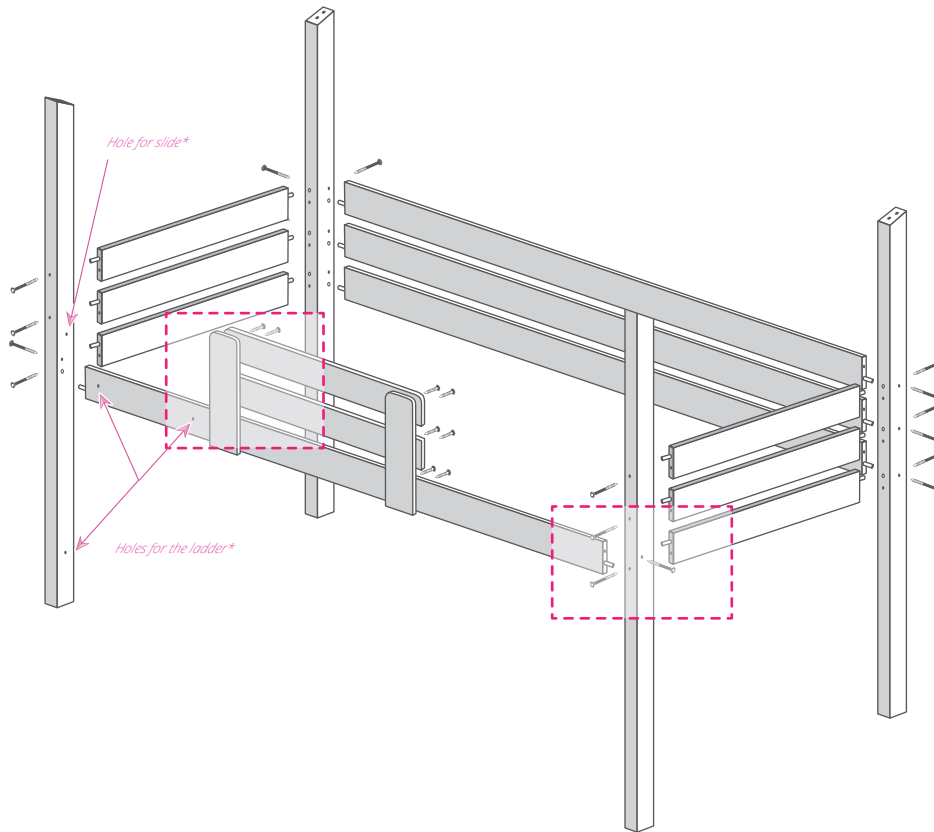

***Important !**

In the case of a bed with a slide, please note on which side you mount the long beam with the holes for the ladder holder. It has an effect on which side the slide will be.

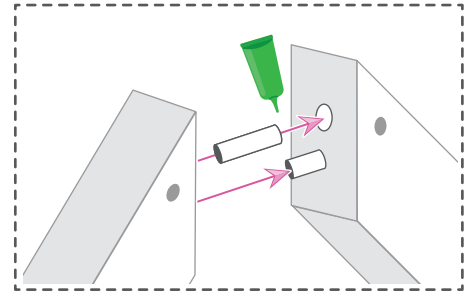
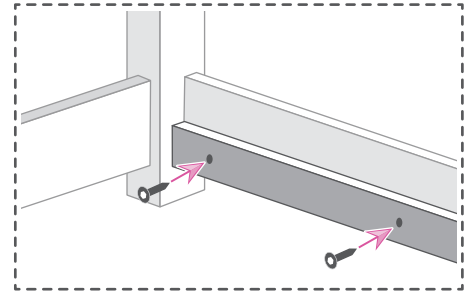
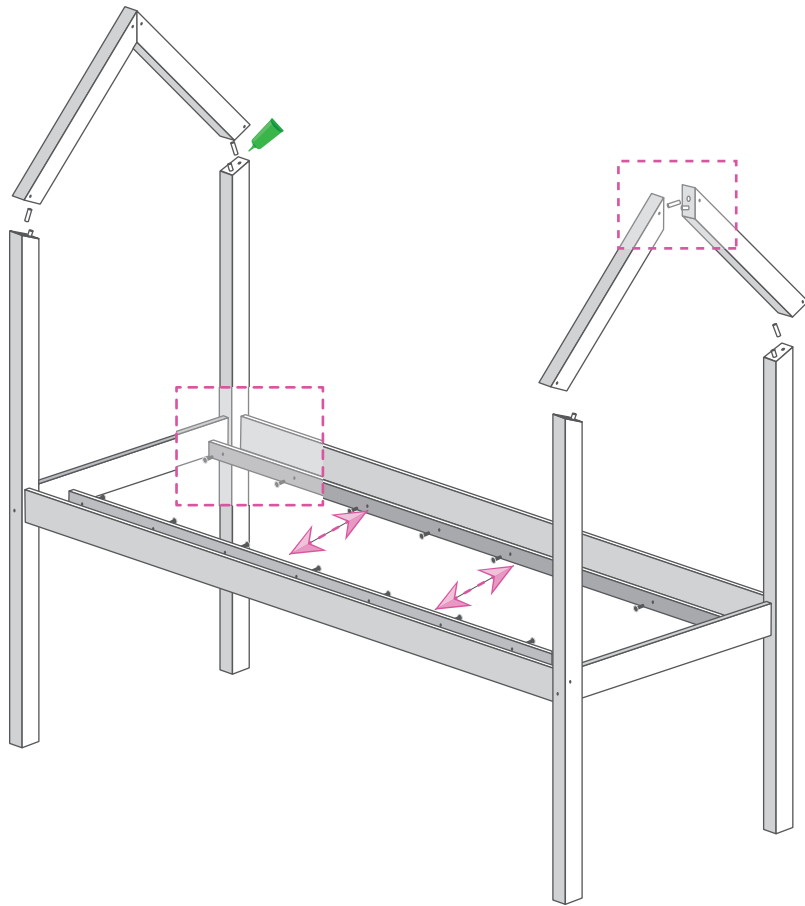

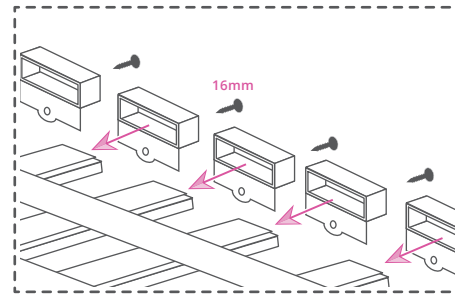
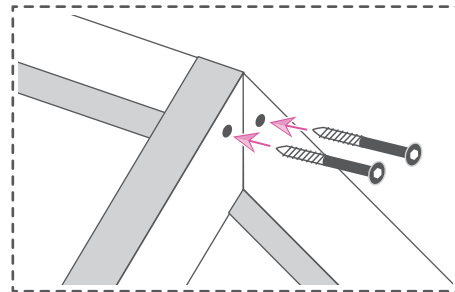
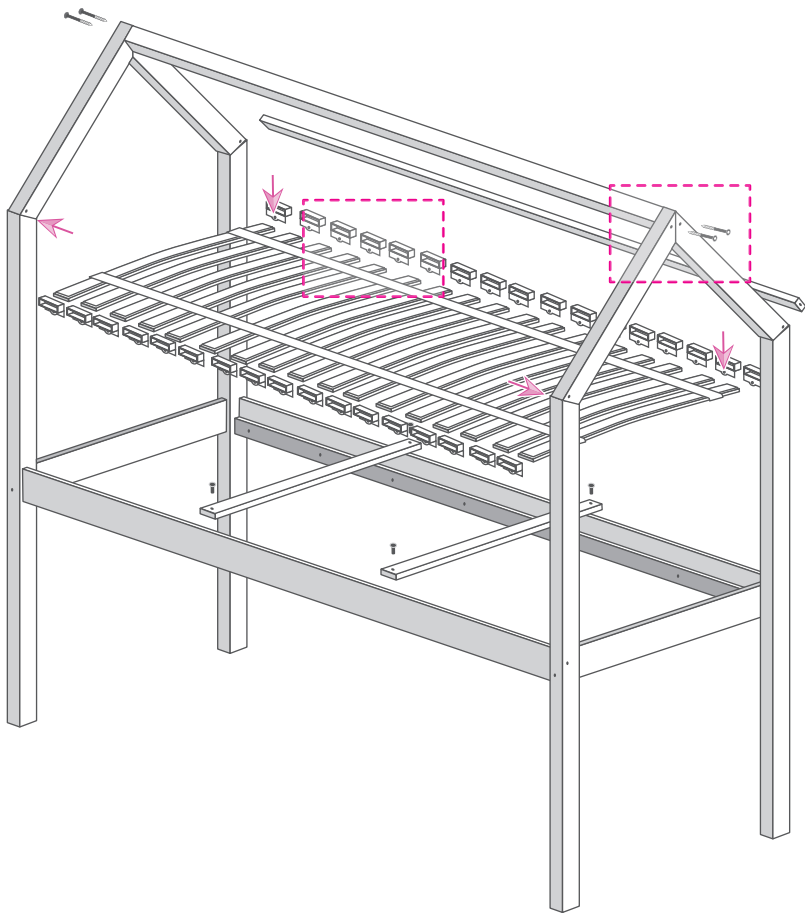

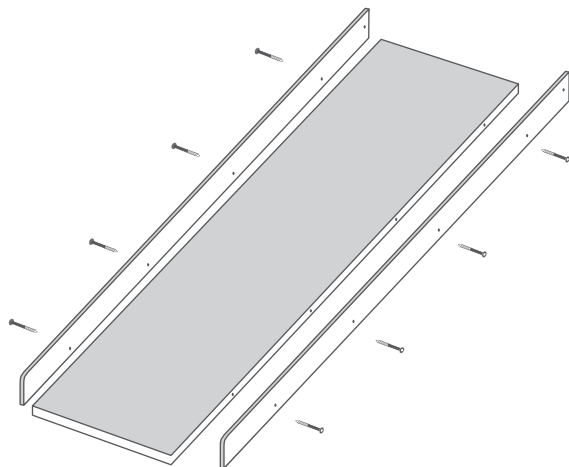
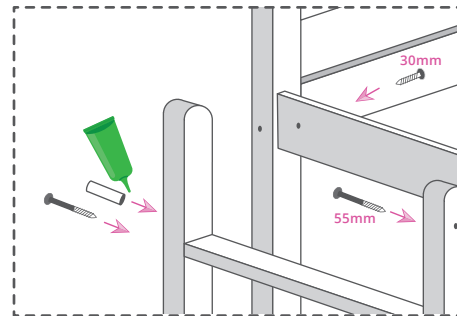
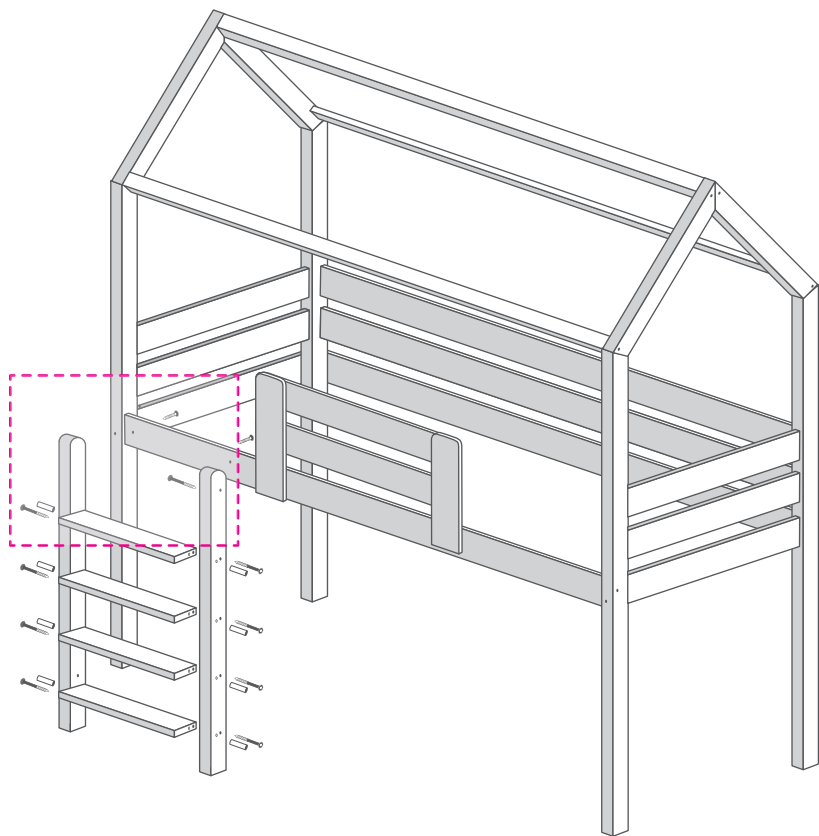

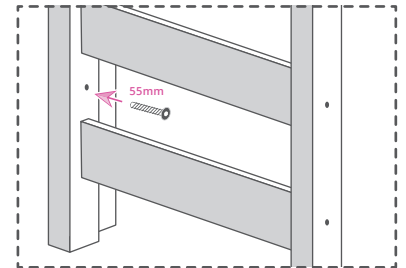
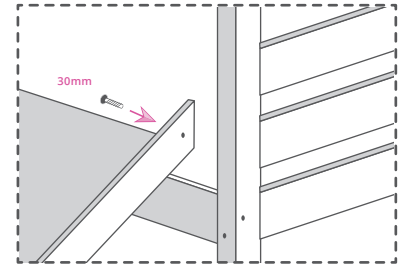
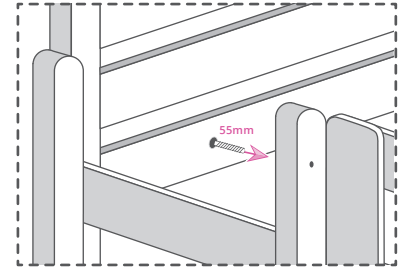
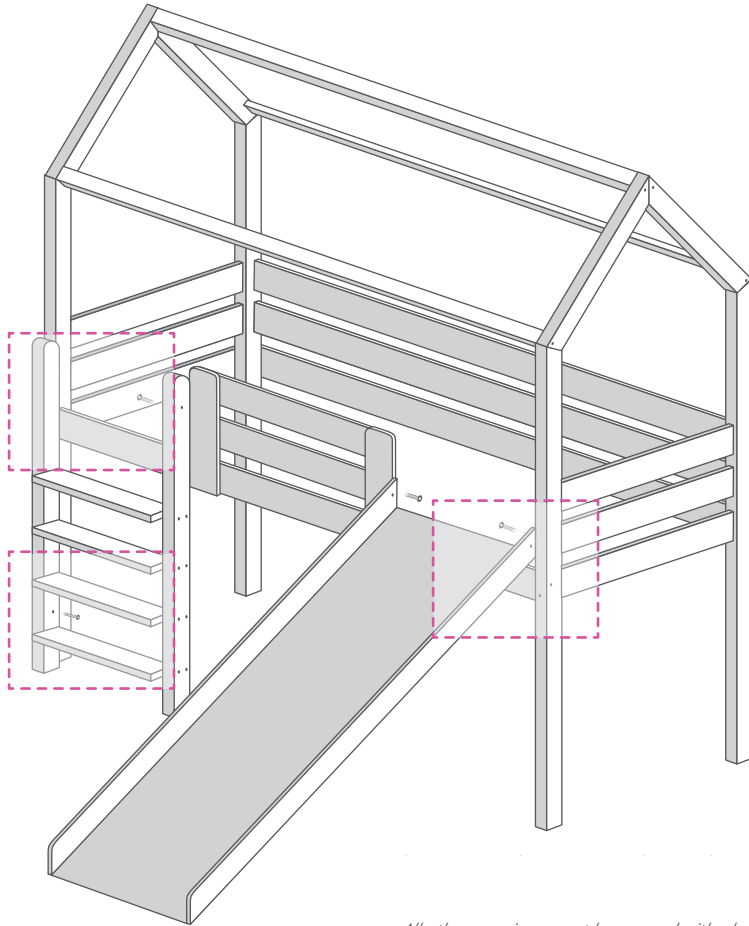

All other openings must be covered with plugs.

WARNING

TO PREVENT SERIOUS INJURIES:

- Never allow a child under 6 years old to be on the upper bunk bed
- Use only mattress with thickness is 9-12 cm
- Assemble the bed according to the instructions
- Don't jump on or under bed.
- Forbidden - more than one person on upper bunk bed.
- Do not hang on construction components

Wooden parts should be cleaned with a dry cloth and cleaning products for raw wood.

Never attach or hang items to any part of the bunk bed that are not designed for use with the bed.

Designed and made according to the standard: PN-EN 747-1+A1:2015-0808

Assembly Manual **PETIT PUK**



Yeaah, great job!!

We hope you are happy with the results too! Don't forget to share a photo with us, it makes us incredibly happy to see the results in our mailbox or on instagram with #petitpuk

Please remember this:

- ♥ Use only mattress with thickness is 8-14 cm height.
- ♥ Beds are for sleeping, not for jumping
- ♥ Prohibit more than one person on the bunkbed.
Do not hang on construction components.
- ♥ Wooden and plastic parts should be cleaned with a dry cloth and ordinary, mild care and cleaning of raw wood
- ♥ Bed parts have a warrantee for 2 years under normal use.
If necessary, contact **PETIT PUK** indicating your name and order number, accompanied by photos's of the situation.

**PETIT
♥ PUK ♥**

www.petitpuk.com f [petitpuk](#)  [petitpuk](#)