



# NIGHTOPTIX™

## Aurora-CLR905 - Compact Laser Rangefinder

In the ever-evolving landscape of military and law enforcement operations, precision and efficiency are paramount. Meet the CLR905 Compact Laser Rangefinder Attachment, a groundbreaking advancement designed to enhance your primary thermal imaging or fusion device with unrivaled accuracy and convenience.

The CLR905 is a game-changing enhancement for military and law enforcement professionals. This compact, lightweight attachment seamlessly integrates with your primary unit, sharing power and adding minimal bulk. With a 905nm wavelength laser, it delivers precise distance data to your primary device, even in challenging conditions. Stay one step ahead with the CLR905, your key to unmatched accuracy and tactical advantage.

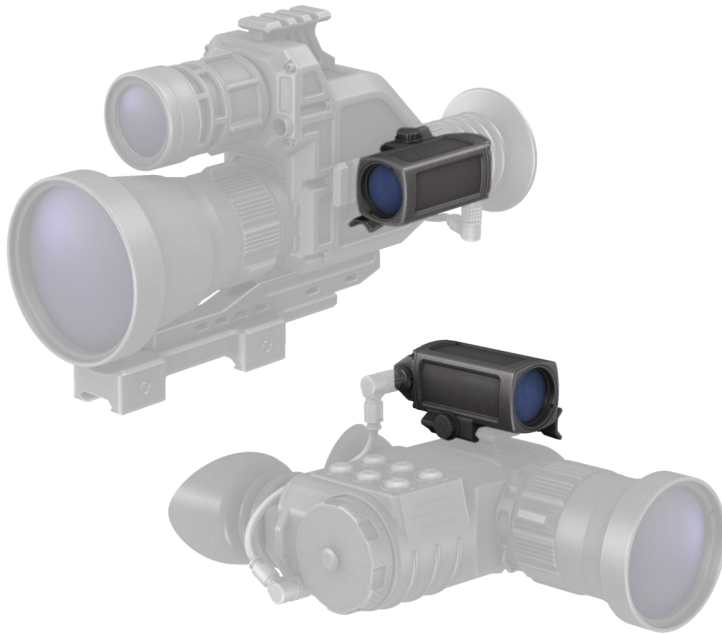

### KEY FEATURES:

- > *Ultra-compact, light weight yet rugged design*
- > *Power-sharing with primary electro-optical unit*
- > *Side- or top-mounted positions*
- > *For hand-held, optics and weapon mountable applications*
- > *Can be paired with various optical-electronic systems*
- > *905nm LRF wavelength*
- > *1200m maximum ranging capability*
- > *Target speed measurement*
- > *Rapid and continuous (uninterrupted) accurate measurements*
- > *3 memory slots for target distance measurements*
- > *Measures speed, heading direction and track angle*
- > *Perfect for spotters, snipers, precision shooters*
- > *Strong aluminum-alloy housing*
- > *Mounts on STANAG 4694 Picatinny rail / Weaver rails*

### APPLICATIONS:

**Military Operations:** Whether conducting reconnaissance, target acquisition, or precision shooting, the CLR905 empowers military personnel with the tools needed to achieve mission success.

**Law Enforcement:** LE agencies can benefit from the CLR905 during surveillance, search and rescue, and specialized operations, enhancing their ability to respond effectively and protect communities.



# NIGHTOPTIX™

## Aurora-CLR905 - Compact Laser Rangefinder

**Ultra-Compact Design:** The CLR905 is engineered with utmost precision, resulting in a form factor that defies industry standards. Its lightweight and rugged enclosure seamlessly integrates with your primary device, adding minimal bulk and maximizing portability.

**Supreme Optical Clarity:** Equipped with a 905nm wavelength laser, this rangefinder attachment ensures crystal-clear target acquisition in a wide range of environmental conditions, including low-light, smoke, and haze, allowing you to maintain the upper hand in every situation.

**Distance to Target:** Instantly acquire precise distance measurements to your target, providing you with critical data to make informed decisions. The CLR905's cutting-edge technology ensures accuracy down to the smallest details, enabling you to assess threats and situations with unmatched confidence.

**Speed Measurement:** Beyond distance, this rangefinder attachment provides real-time speed data, enabling you to track and anticipate target movements. This invaluable information enhances your situational awareness and tactical advantage, ensuring that you stay one step ahead.

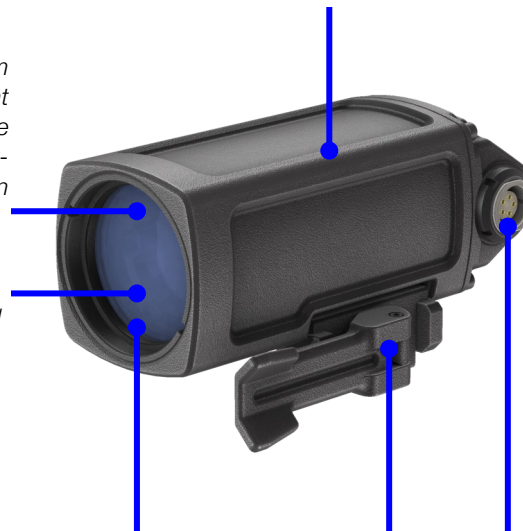

**Seamless Integration:** Effortlessly attach the CLR905 to your thermal imager or fusion device, transforming it into a multifunctional powerhouse. No additional power sources are required, as this attachment draws power directly from your primary device, eliminating the need for extra batteries and streamlining your equipment loadout.





**NIGHTOPTIX™**

## Aurora-CLR905 - Compact Laser Rangefinder

<b>TECHNICAL SPECIFICATIONS</b>	
Ranging Capability	3m .. 1200m
Minimum Measuring Time	0.4s
Distance-To-Target Precision	Less than 1m
Distance Units	User-Selectable: Meters or Yards
Compass	High Accuracy Magnetic and Gyro-Compass
Laser Safety Class	Class 1 (Eye Safe)
Wavelength	Eye Safe 905nm
Performance to NATO Target (2.3x2.3m)	530m (30% Reflectivity)
Power Source	Shared with Primary Unit
Max. Dimensions	74 x 42 x 39 mm
Weight	110 grams
Mounting Interface	STANAG 4694 Picatinny Rail / Weaver Rail
Environmental Protection	IP67
Operating Temperature	-40°C .. +50°C
Storage Temperature	-50°C .. +60°C
Warranty	7 Years
Export	Available Worldwide

### **STANDARD EQUIPMENT: WHAT'S IN THE BOX**

1	CLR905 Unit
2	Connection Cable
3	Cleaning Kit (3-in-1 Multi-Pen + Cleaning Cloth)
4	Soft Carrying Pouch
5	Hard Carrying Case
6	User Manual