

ProBreeze[®]

Instruction Manual

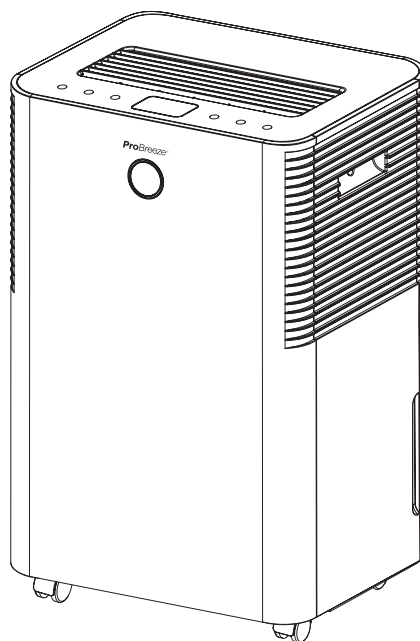

Model PB-D-24-WF 20L Smart Compressor Dehumidifier

IMPORTANT INSTRUCTIONS
– RETAIN FOR FUTURE USE

CONTENTS

EN Safety Instructions.....	Page 3
Specific Information Regarding R290 Refrigerant Gas.....	Page 6
Symbols Explained	Page 7
Specification.....	Page 7
Parts.....	Page 8
Positioning your Unit.....	Page 8
Operating Instructions.....	Page 9
Continuous Drainage.....	Page 12
Wi-Fi and Smart Life Set-Up.....	Page 12
Error Codes.....	Page 14
Cleaning and Storage.....	Page 15
Declaration of Conformity.....	Page 16
PSTI Statement of Compliance	Page 16
Recycling and Disposal.....	Page 17



**20L SMART COMPRESSOR
DEHUMIDIFIER
MODEL PB-D-24-WF**

Thank you for choosing to purchase a product from Pro Breeze. Please read the entire manual before first use and keep in a safe place for future reference.

SAFETY INSTRUCTIONS

PLEASE READ AND SAVE THESE IMPORTANT SAFETY INSTRUCTIONS.

When using electrical appliances, basic safety precautions should always be followed to reduce the risk of fire, electric shock, and injury to persons, including the following:

⚠ WARNING: TO AVOID THE RISK OF ELECTRICAL SHOCK, FIRE OR INJURY TO PEOPLE, ALWAYS TURN THE APPLIANCE OFF, UNPLUG THE POWER CORD FROM THE ELECTRICAL OUTLET AND EMPTY THE WATER TANK BEFORE HANDLING, CLEANING OR SERVICING THE APPLIANCE.

- Use this dehumidifier only as described in this manual. Any other use not recommended by the manufacturer may cause fire, electric shock, or injury to person.
- Always unplug the dehumidifier when not in use.
- Keep the dehumidifier out of reach of children and pets.
- Do not leave children alone or unattended in the area where the dehumidifier is in use.
- Children shall not play with the dehumidifier.
- Cleaning and user maintenance shall not be made by children without supervision.
- Dispose of water held by the dehumidifier. This water is not drinkable
- This dehumidifier can be used by children aged from 8 years and above and persons with reduced physical, sensory or mental capabilities or lack of experience and knowledge if they have been given supervision or instruction concerning use of the appliance in a safe way and understand the hazards involved.

- Never leave the dehumidifier unattended while in use. Always turn the dehumidifier off and disconnected from the power supply when not in use.
- Never place anything on top of the dehumidifier.
- Ensure that the mains supply (including voltage, frequency and power) complies with the rating label of the dehumidifier.
- Do not operate the dehumidifier with wet hands.
- Do not use this dehumidifier near water or in the immediate surroundings of a bath, shower or a swimming pool. Never place the dehumidifier where it may fall into a bathtub or other water container.
- Do not allow water or other liquids to run into the interior of the dehumidifier, as this could create a fire and/or electrical hazard.
- This dehumidifier is intended for indoor household use and similar applications. Do not use outdoors.
- The mains cable should not hang down from the surface on which the dehumidifier is placed in order to prevent the dehumidifier from being pulled down.
- To avoid a circuit overload when using this dehumidifier, do not operate another high-wattage dehumidifier on the same electrical circuit.
- Always plug the dehumidifier directly into a wall socket. Avoid using extension leads where possible as they may overheat and cause a risk of fire.
- Do not use this dehumidifier with an external programmer, timer switch or any other device which would switch the dehumidifier on automatically unless this has already been pre-built into the appliance by the manufacturer.
- Do not pull on the power cord. Never move, carry, or hang the dehumidifier by the power cord.
- Do not kink or wrap the power cord and plug around the dehumidifier, as this may cause the insulation to weaken or split, particularly where it enters the dehumidifier.
- Do not operate the dehumidifier with any safety guards removed.
- Do not operate the dehumidifier if there are any signs of damage to the appliance or accessories supplied.
- Do not attempt to repair or adjust any electrical or mechanical elements in the dehumidifier. Doing so may be unsafe and will void your warranty.
- The appliance shall be installed in accordance with national wiring regulations.
- Do not cover the dehumidifier whilst in use.
- When moving the dehumidifier, ensure it is kept in an upright position.
- The dehumidifier must have a minimum 50cm clearance around all sides.
- Avoid placing the power cord in areas where it can become a tripping hazard. Do not place the power cord under carpeting or cover it with rugs, runners or similar.
- Place the dehumidifier on a flat, stable and dry surface and always keep the appliance in an upright position. Operating the appliance in any other position could cause a hazard.
- There may be trace of odour during the first few minutes of initial use. This is normal and will quickly disappear.
- Do not place the dehumidifier against a wall or other appliances.
- Do not cover, obstruct or push objects into the vents and opening of the dehumidifier as this may cause an electric shock, fire or damage the dehumidifier.
- Do not operate the dehumidifier without the filter.
- Do not use mechanical devices to accelerate the appliances defrosting process.
- Do not place the continuous drainage hose outside when the temperature falls below 1C.
- Do not use the dehumidifier near petrol, paints, flammable gases, ovens, or other heating sources.
- Do not operate the dehumidifier with the water tank removed.
- Ensure the mains cable is fully extended before use and arrange it so that it is not in contact with any part of the dehumidifier.
- If the supply cord is damaged, it must be replaced by the manufacturer, its service agent or a similarly qualified person in order to avoid a hazard.

- Never insert fingers or metal objects into the vents and openings of the appliance.
- The unit's circuit board(PCB) is designed with a fuse to provide overcurrent protection. The specifications of the fuse are printed on the circuit board.

SPECIFIC INFORMATION REGARDING R290 REFRIGERANT GAS







⚠ WARNING: THE DEHUMIDIFIER MUST BE INSTALLED, OPERATED AND STORED IN A ROOM WITH A FLOOR AREA LARGER THAN 4M².

- This appliance contains 0.054kg (54g) of R290 refrigerant gas.
- R290 is a refrigerant gas that complies with the European directive on the environment.
- Do not puncture any part of the refrigerant circuit.
- Be aware that R290 refrigerant is odourless and does not have the odour normally associated with natural gas and propane tanks.
- Do not use means to accelerate the defrosting process or to clean, other than those recommended by the manufacturer.
- The dehumidifier must be placed in an area without any continuous sources of ignition such as open flames, gas, or electrical appliances in operation.
- Do not puncture and do not burn the refrigerant circuit.
- If the appliance is installed, operated or stored in a nonventilated area, the room must be designed to prevent the accumulation of refrigerant leaks resulting in a risk of fire or explosion due to ignition of the refrigerant

caused by electric heaters, stoves, or other sources of ignition.

- The appliance must be stored in such a way as to prevent mechanical failure.
- Individuals who operate or work on the refrigerant circuit must have the appropriate certification issued by an accredited organisation that ensures competence in handling refrigerants according to a specific evaluation recognised by associations in the industry.
- Maintenance and repairs that require the assistance of other qualified personnel must be performed under the supervision of an individual specified in the use of flammable refrigerants.

SYMBOLS EXPLAINED

	For indoor use only.		Please read instruction manual and retain for future use.
	Equipment complies with the applicable UK safety requirements and regulations.		Equipment complies with the applicable EU safety requirements and regulations.

SPECIFICATION

Model:	PB-D-24-WF-UK	Voltage:	220-240V~
Frequency:	50Hz	Power:	330W
Product Dimensions:	305 x 240 x 495mm	Net Weight:	13kg
Fuse:	AC 250V~, 3.15/2A		

PARTS

Front

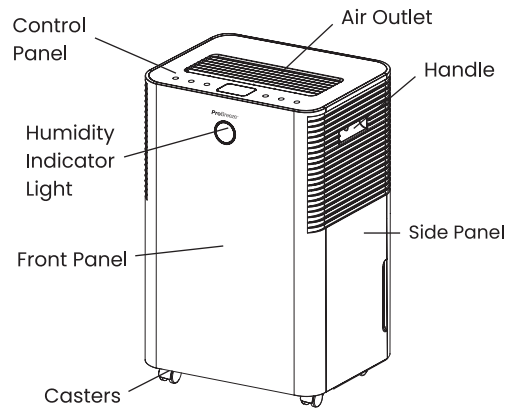

Back

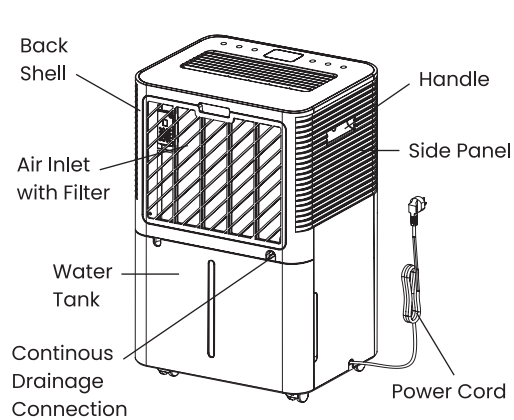

If you find you're missing any parts from your order, please contact our customer care team by emailing help@probreeze.com for fast and friendly help.

These images are for reference only, please refer to your product.

POSITIONING YOUR UNIT

- For optimal performance, place the unit in an enclosed space and close all doors, windows and all outside openings.
- This unit is designed to operate in temperatures between 5°C and 35°C.
- Place the unit in an area where the temperature will not fall below 5°C, temperatures lower than this may cause the coils to freeze. This would lead to a reduction in performance.
- Place the unit on a smooth, level surface, strong enough to support the unit with a full water tank.
- Allow at least 50cm of space behind the air outlet (at the top of the unit) and 20cm of space on all other sides of the unit for good air circulation.
- If placed near an enclosed storage area (wardrobe, cupboard etc), ensure there is adequate circulation of air.
- There are four wheels attached to the unit for ease of transportation. Do not force the wheels to move over carpet or other uneven surfaces.

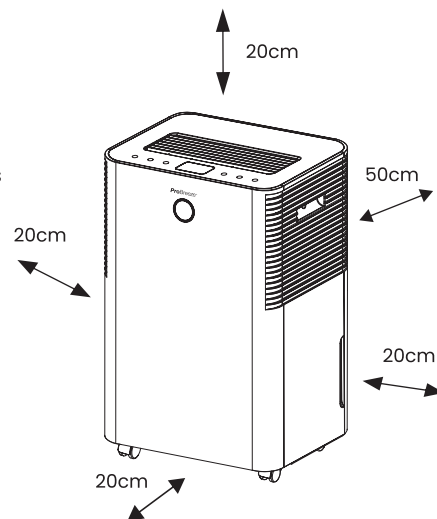

OPERATING INSTRUCTIONS

1. Timer Indicator
2. Auto Mode Indicator
3. Laundry Mode Indicator
4. Night Mode Indicator
5. On/Off Indicator
6. Low Fan Speed Indicator
7. High Fan Speed Indicator
8. Wi-Fi Indicator
9. Target/Current Humidity
10. Tank Full Indicator
11. Lock Indicator

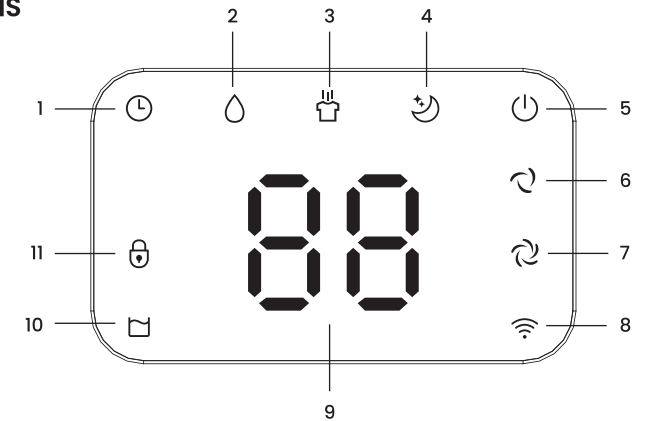

Quick Start Guide







Follow these 3 steps to get your Pro Breeze Dehumidifier up and running:

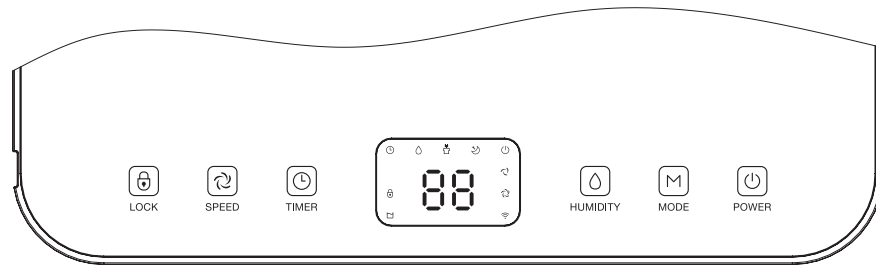



1. **Turn Your Unit On:** Plug in your unit and press the power button to activate the dehumidifier. It will start in auto mode with high speed and a default humidity level of 50%.
2. **Select A Mode:** Press the mode button to cycle through the three modes:
 - Auto Mode: This mode lowers your environment's humidity to your set level; the unit will turn off when this level is reached and reactivate if the room's humidity exceeds the set level.
 - Laundry Mode: Use this mode for continuous operation, ideal for efficient clothes drying.
 - Night Mode: Similar to Auto Mode, with dimmed lights and adjustable wind speed.
3. **Choose Your Ideal Humidity:** In auto or night mode, use the humidity button to set your desired humidity level within the range of 30-80%. The chosen level becomes active after 5 seconds. We recommend a humidity of between 40% - 50% for a healthy home.

Your dehumidifier is now working to achieve your ideal environment! For more details, refer to the table below for advanced settings, and features.

Control panel



 POWER	Power Button	<p>Turning On/Off: Plug the unit into power outlet and press the power button to turn on the appliance. In the initial start up the unit will default to Auto Mode, with high wind speed and humidity of 50%. Then the appliance will start up with the previous settings. Press the power button again to turn the unit into standby mode.</p> <p>When in standby mode, the display will show the current humidity of the room with slightly dimmed lights.</p>
 SPEED	Fan Speed Button – change the fan speed	<p>In auto mode, press the fan speed button to switch between high and low fan speeds. The corresponding indicator will light up.</p>
 TIMER	Timer Button – Set a turn on/off timer	<p>Press the timer button  to activate the timer and press the humidity button  to cycle between 1-24 hours, in increments of 1 hour. The hours set will be displayed on the LED display. When the LED display reads '00', the timer is turned off and the indicator light will turn off. (See the setting a timer section below for further instructions”).</p> <p>Press and hold this button for 3 seconds to enter Wi-Fi pairing mode (see the Wi-Fi and smart life set-up section for full instruction).</p>
 HUMIDITY	Humidity Button – Set your humidity	<p>In auto or night mode, press the humidity button to select your preferred humidity level (between 30% and 80%), which will set after 5 seconds. Long press the humidity button to briefly view the room temperature; the display returns to showing the current humidity after 5 seconds.</p>

 LOCK	Lock Button – a child lock	<p>Long press the lock button to activate child lock. All buttons on the appliance will be locked and the child lock indicator will be on.</p> <p>To remove child lock, press the lock button again. The indicator will turn off.</p>
 MODE	Mode Button – choose between auto, laundry and night mode	<p>Press this button to cycle between the dehumidifier's 3 modes:</p> <p> Auto Mode: In this mode, the dehumidifier works to lower your environment's humidity to your set humidity (see humidity button section above). The dehumidifier will automatically turn off if the environment's humidity is lower than the set humidity. When the environment's humidity exceeds the set humidity the fan will automatically turn on and 3 seconds later the compressor will activate.</p> <p> Laundry Mode: In this mode, the dehumidifier operates continuously to enhance clothes drying efficiency. The fan is automatically set to high fan speed for better air circulation and faster and more effective drying.</p> <p>This mode is ideal for drying laundry and combatting mould and damp with the continuous operation.</p> <p> Night Mode: Long press the mode button to activate night mode. Operates the same as Auto Mode, fan speed is automatically low, and all lights will turn off after 10 seconds for a restful night without a dip in dehumidifying performance.</p>
	Colour Display	<p>The light will display different colours according to the ambient humidity of the environment:</p> <ul style="list-style-type: none"> • Blue – Below 45% • Green – Between 45% and 65% • Red – Above 65% <p>Note: The light will also be red if any of the error codes are displayed on the LED display. See the 'error codes' section for more information.</p>

Setting a timer

Setting a Turn-On Timer: When the dehumidifier is off, press the timer button, then use the humidity button to set the number of hours before you want it to turn on. The timer light will illuminate when a timer is set.

Setting a Turn-Off Timer: When the dehumidifier is on, press the timer button, then use the humidity button to set the number of hours before you want it to turn off. The timer light will illuminate when a timer is set.

CONTINUOUS DRAINAGE

To connect the drain hose to the unit:

1. Remove the water tank by pulling on the handles on either side of the tank at the rear of the unit.
2. Insert one end of the hose into the continuous drainage hole of the unit. Ensure it is connected securely.
3. Place the other end of the hose into a bucket or a drain.
4. Ensure the hose is not bent or blocked.

Note: Gravity will pull the water out of the unit into your chosen drainage area. Ensure the chosen area is not higher than the unit.

Emptying the Water Tank:

- When the water tank is full, the unit will beep 5 times, the tank full indicator will turn on and the display will show FL.
- Press the power button to turn off the unit.
- Slide the water tank out of the body of the dehumidifier.
- Empty the water tank into a sink/drain and wipe clean the inside and the outside.
- Replace the empty tank in the unit.
- Press the power button to resume operating.
- If the Water Full light does not turn off, check that the water tank is correctly in place.

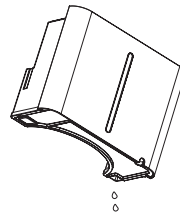
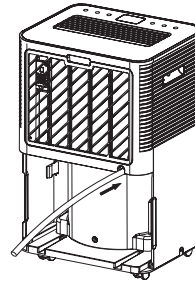
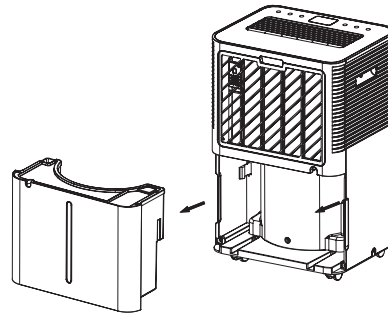

WI-FI AND SMART LIFE SET-UP

Smart Life is a centralised app for smart device management. Control your unit from the Smart Life app, set up schedules to turn your unit on and off and set up voice control.

Note: Ensure your Wi-Fi network is set to 2.4GHz for successful pairing.

Pair Your Device in 4 Steps:

1. Register: download the Smart Life app on the Google Play or Apple app store. Sign in/register for an account.
2. Prepare your device: Once you're all signed in hold down the timer button for 3 seconds, to turn on the unit's Wi-Fi pairing mode.
3. Add your device: once the unit is in Wi-Fi pairing mode, open the Smart Life app press "+" in the top right corner and press "add device".

4. Pair your device: Then the app will scan for devices and then your unit (if it is in pairing mode) will show up as shown below. Press add. Then type in the password for the Wi-Fi your phone is on. Now your unit is connected to the Smart Life app.

Within the app, you can set your unit's mode, target humidity, fan speed and set an on/off schedule. Follow the steps below to connect your unit to an Amazon Echo or Google Home Speaker for voice control.

Amazon Echo Set-Up

Before connecting the appliance to an Amazon Echo device via Wi-Fi, ensure:

- The Smart Life app must have already been downloaded and the appliance successfully paired with the Smart Life app.
- The Amazon Alexa app must have already been downloaded.
- An Amazon Echo device must be paired with the Amazon Alexa app.
- To connect Pro Breeze smart dehumidifier to an Amazon Echo device via Wi-Fi through the Smart Life app follow the below steps.

Link the Amazon Alexa app to the Smart Life app:

- **Step 1:** Open the Amazon Alexa app.
- **Step 2:** Go to Skills.
- **Step 3:** Search for Smart Life by Tuya Inc.
- **Step 4:** Tap Enable.
- **Step 5:** Follow the on-screen instructions to connect your Smart Life account with the Amazon Alexa app.

Pair the Amazon Alexa app to the appliance:

- **Step 1:** Open the Amazon Alexa app.
- **Step 2:** Go to Devices.
- **Step 3:** Tap the "+" symbol to add a new device.
- **Step 4:** Tap the appliances name and follow the on-screen instructions to pair the Amazon Alexa app to the appliance.
- **Step 5:** Use Amazon Alexa to control the appliance e.g. "Turn <device name> on" "Turn <device name> off". **Note:** The default <device name> is "20 Litre Compressor Dehumidifier". Change your device's name within the Smart Life app.

Google Home Set-Up

Before connecting the appliance to a Google Home device via Wi-Fi, ensure:

- The Smart Life app must have already been downloaded and the appliance successfully paired with the Smart Life app.
- The Google Home app must have already been downloaded.
- A Google Home device must be paired with the Google Home app.

To connect Pro Breeze smart dehumidifier to a Google Home device, via Wi-Fi through the Smart Life app follow the below steps:

- **Step 1:** Open the Google Home app.
- **Step 2:** Tap the + symbol.
- **Step 3:** Tap Set up device.
- **Step 4:** Tap Have something already set up?
- **Step 5:** Search for Smart Life by Tuya Inc.
- **Step 6:** Follow the on-screen instructions to connect your Smart Life account with and the appliance to the Google Home app.
- **Step 7:** Return to the Google Home screen.
- **Step 8:** Tap the room assigned to the appliance and tap the appliance's name.
- **Step 9:** Use Google Assistant to control the appliance e.g. "Turn <device name> on" "Turn <device name> off".

ERROR CODES

ERROR CODE	CAUSE	SOLUTION
E0	The wiring has malfunctioned.	Contact Pro Breeze Customer Care by sending an email to help@probreeze.com or via our website www.probreeze.com .
E1/2	The humidity sensor is unable to detect the humidity of the environment.	

CLEANING AND STORAGE

⚠ WARNING: ALWAYS TURN THE APPLIANCE OFF AND UNPLUG THE POWER CORD FROM THE ELECTRICAL OUTLET BEFORE HANDLING OR CLEANING IT.

⚠ CAUTION: DO NOT ALLOW WATER OR OTHER LIQUIDS TO RUN INTO THE INTERIOR OF THE APPLIANCE, AS THIS COULD CREATE A FIRE AND/OR ELECTRICAL HAZARD.

⚠ CAUTION: DO NOT USE ANY ABRASIVE CLEANERS OR SOLVENTS, AS THIS CAN DAMAGE THE APPLIANCE.

- Do not attempt to clean the dehumidifier in any other way than that detailed by the manufacturer.
- Never leave water in the water tank when the appliance is not in use.

Cleaning the body of the dehumidifier:

- Turn the dehumidifier off and unplug the power cord.
- Clean the exterior of the dehumidifier by wiping it with a soft, damp cloth.
- Dry the dehumidifier with a soft clean cloth.

Cleaning the air filter:

Note: As the filter gets clogged the dehumidifying capacity of the unit is lowered. It is important to clean the rear air filter every 2 weeks.

- Remove the air filter by gently pulling on the handle at the top of the filter cover.
- To extend the lifespan of the filter, use a vacuum cleaner, using the brush attachment to remove dust from the surface of the filter.

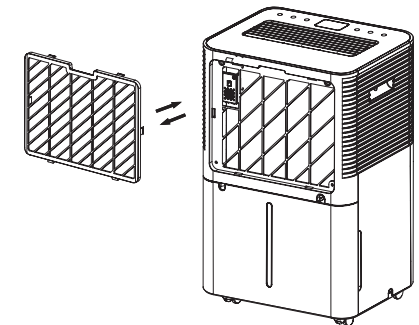

- Return the clean filter to the dehumidifier.

Cleaning the water tank:

- Remove and empty the water tank as per the instructions in the “Emptying the water tank” section.
- Remove the water tank’s lid by removing the handle and lifting the water tank’s lid upwards.
- Clean the water tank with warm tap water and mild detergent (e.g. washing up liquid). **Note:** Do not use boiling water to clean the water tank.
- Ensure to remove any scale or deposits that have formed inside the water tank.
- Wipe all surfaces dry before placing the water tank’s lid handle.
- Then return the water tank to the unit.

Storage:

- To store your product, we recommend using the original or a similar-sized box. Store in a safe, clean and dry place, away from direct sunlight and out of reach of children when not in use.
- Always empty the water tank, and clean and dry the appliance when not in use to prevent mould.
- Empty and clean the dehumidifier before storage. Clean the appliance before the next use post-storage.

DECLARATION OF CONFORMITY

-

Hereby, One Retail Group Limited declares that the radio equipment type PB-D-24-WF-UK is in compliance with the Radio Equipment Regulations 2017. The full text of the UK Declaration of Conformity is available at the following internet address: <https://probreeze.com/pages/ec-declaration-of-conformity/>

PSTI STATEMENT OF COMPLIANCE

-



Hereby, One Retail Group Limited declares that PB-D-24-WF-UK is in compliance with The

Product Security and Telecommunications Infrastructure (Security Requirements for Relevant Connectable Products) Regulations 2023. The full text of the UK PSTI Statement of Compliance is available at the following internet address: <https://probreeze.com/pages/psti-compliance/>

RECYCLING AND DISPOSAL

-

Waste electrical and electronic products (WEEE), batteries, accumulators and packaging should not be disposed of with general household waste. This is to prevent possible harm to the environment and human well-being and to help conserve our natural resources. Most electrical products with a plug, battery, or cable can be recycled. Contact your local council, household waste disposal service, or the store where you purchased the product for information regarding the collection schemes in your area.

	Waste Electrical and Electronic Equipment (WEEE)	This symbol on the product and/or packaging indicates that Waste Electrical products (WEEE) under Directive 2012/19/EU which governs used electrical and electronic appliances, should not be disposed of with general household waste.
	The Mobius Loop	This symbol indicates that the product or packaging is capable of being recycled.

Take-Back Scheme

Waste electrical products (WEEE) can be sent to One Retail Group for recycling and disposal when you purchase a new product from One Retail Group, on a like-for-like basis. For more information on how to recycle this product please visit www.probreeze.com

The end-user of electrical and electronic products (WEEE) is responsible for separating old batteries and lamp bulbs before they are handed over to a designated disposal and recycling service. Waste batteries can also be disposed of in collection bins, which can be found in most local supermarkets and household waste recycling centres.

Personal Data Protection

Electrical and electronic products (WEEE) may contain personal user data, depending on the type of product. This may include app-linked products that connect to wifi. The end-user is responsible for deleting the data on the waste electrical and electronic products prior to disposal.



www.probreeze.com

One Retail Group, Ryland House,
24A Ryland Road, Kentish Town, London, NW5 3EH, United Kingdom

EU Authorised Representative: Brandrep Limited, The Black Church,
St Mary's Pl N, Dublin, D07 P4AX, Ireland

© Copyright 2024