

# *ProBreeze*®

Instruction Manual

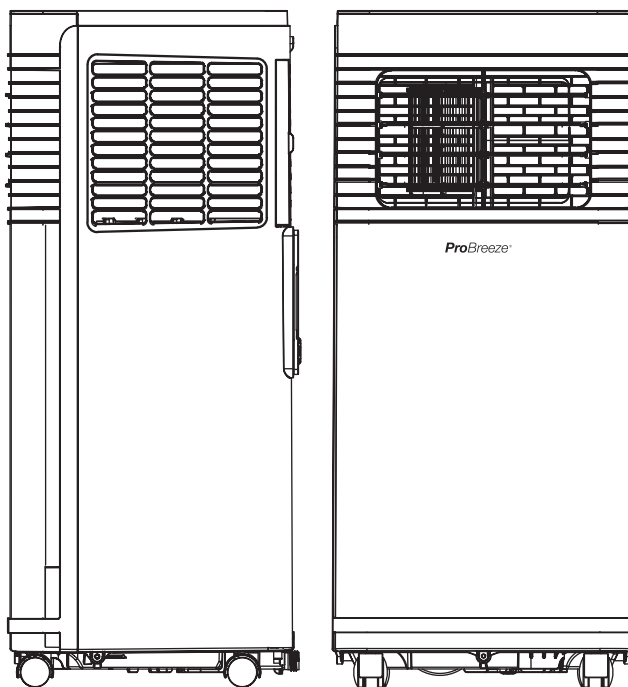

## **Model PB-AC08**

**5000 BTU Smart Portable Air Conditioner**

**IMPORTANT INSTRUCTIONS  
– RETAIN FOR FUTURE USE**

# CONTENTS

<b>EN</b>	Safety Instructions.....	Page 3
	Battery Warnings.....	Page 6
	Specific Information Regarding R290 Refrigerant Gas.....	Page 7
	Symbols Explained.....	Page 8
	Specification.....	Page 8
	Parts.....	Page 9
	Control Panel.....	Page 10
	Installation.....	Page 11
	Operating Instructions.....	Page 14
	Wifi and Smart Life App Set-Up.....	Page 15
	Emptying the Water Tank and Continuous Drainage.....	Page 17
	Cleaning.....	Page 18
	Storage.....	Page 20
	Safety Features.....	Page 20
	Troubleshooting.....	Page 21
	Recycling and Disposal.....	Page 22
	Declaration of Conformity.....	Page 23

# ProBreeze®

## 5000 BTU SMART PORTABLE AIR CONDITIONER | MODEL PB-AC08

Thank you for choosing to purchase a product from Pro Breeze. Please read the entire manual carefully prior to first use and keep in a safe place for future reference.

### SAFETY INSTRUCTIONS

#### PLEASE READ AND SAVE THESE IMPORTANT SAFETY INSTRUCTIONS.

When using electrical appliances, basic safety precautions should always be followed to reduce risk of fire, electric shock, and injury to persons, including the following:

**⚠ WARNING: TO AVOID THE RISK OF ELECTRICAL SHOCK, FIRE OR INJURY TO PEOPLE, ALWAYS TURN THE APPLIANCE OFF, UNPLUG THE POWER CORD FROM THE ELECTRICAL OUTLET AND EMPTY THE WATER TANK BEFORE HANDLING, CLEANING OR SERVICING THE APPLIANCE.**

**⚠ CAUTION: THIS APPLIANCE IS HEAVY. TAKE EXTRA CARE WHEN HANDLING.**

- Use this appliance only as described in this manual. Any other use not recommended by the manufacturer may cause fire, electric shock, or injury to person.
- Do not cover the appliance whilst in use.
- Always unplug the appliance when not in use.
- Keep the appliance out of reach of children and pets.
- Do not leave children alone or unattended in the area where the appliance is in use.
- Children must be supervised not to play with the appliance.
- Cleaning and user maintenance shall not be made by children unless continuously supervised.
- Dispose of water held by the appliance. This water is not drinkable

- The appliance is not to be used by persons (including children) with reduced physical, sensory or mental capabilities, or lack of experience and knowledge, unless they have been given supervision or instruction.
- When moving the appliance, ensure it is kept in an upright position.
- The appliance must have a minimum 50cm clearance around all sides.
- Never leave the appliance unattended while in use. Always turn the appliance off and disconnected from the power supply when not in use.
- Avoid placing the power cord in areas where it can become a tripping hazard. Do not place the power cord under carpeting or cover it with rugs, runners or similar.
- Place the appliance on a flat, stable and dry surface and always keep the appliance in an upright position. Operating the appliance in any other position could cause a hazard.
- Do not place anything on top of the appliance while it is in use.
- Ensure that the mains supply (including voltage, frequency and power) complies with the rating label of the appliance.
- There may be trace of odour during the first few minutes of initial use. This is normal and will quickly disappear.
- Do not cover the appliance or restrict the air flow of the inlet or exhaust grills whilst in use.
- Do not cover, obstruct or push objects into the vents and opening of the appliance as this may cause an electric shock, fire or damage the appliance.
- Do not operate the appliance with wet hands.
- Do not operate the appliance without the filter.
- Do not use this appliance near water or in the immediate surroundings of a bath, shower or a swimming pool. Never place the appliance where it may fall into a bathtub or other water container.
- Do not allow water or other liquids to run into the interior of the appliance, as this could create a fire and/or electrical hazard.
- Do not use mechanical devices to accelerate the appliance's defrosting process.
- This appliance is intended for indoor household use and similar applications. Do not use outdoors.
- Do not use the appliance near petrol, paints, flammable gases, ovens, or other heating sources.
- The mains cable should not hang down from the surface on which the appliance is placed in order to prevent the appliance from being pulled down.
- To avoid a circuit overload when using this appliance, do not operate another high-wattage appliance on the same electrical circuit.
- Always plug the appliance directly into a wall socket. Avoid using extension leads where possible as they may overheat and cause a risk of fire.
- Do not use this appliance with an external programmer, timer switch or any other device which would switch the appliance on automatically unless this has already been pre-built into the appliance by the manufacturer.
- Do not pull on the power cord. Never move, carry, or hang the appliance by the power cord.
- Do not kink or wrap the power cord and plug around the appliance, as this may cause the insulation to weaken or split, particularly where it enters the appliance.
- Do not operate the appliance with the water tank removed.
- Do not operate the appliance with any safety guards removed.
- Do not operate the appliance if there are signs of damage to the appliance, power cord, or any of the accessories supplied. If the supply cord is damaged, it must be replaced by the manufacturer, its service agent or a similarly qualified person in order to avoid a hazard.

- Do not attempt to repair or adjust any electrical or mechanical elements in the appliance. Doing so may be unsafe and will void your warranty.
- Never insert fingers or metal objects into the vents and openings of the appliance
- Do not move the appliance whilst it is in use.

## BATTERY WARNINGS

This product is supplied with 2 x AAA disposable batteries.

### PLEASE READ AND SAVE THESE IMPORTANT SAFETY INSTRUCTIONS

**⚠ WARNING: KEEP BATTERIES OUT OF REACH OF CHILDREN.**

Choking hazard. Do not swallow. Harmful if swallowed. Swallowing can lead to chemical burns, perforation of soft tissue, and death. Severe burns can occur within 2 hours of ingestion. **If you suspect your child has swallowed a battery seek medical attention immediately.**

- This product only uses a 2 x AAA battery. It is not compatible with other battery types.
- Do not allow children to handle batteries.
- If the battery compartment does not close securely, stop using the product and keep it away from children.
- Ensure that the battery is installed with the correct polarity (+ and -).
- Remove exhausted battery promptly.
- Always inspect new batteries before use. Damaged or weak batteries may leak acid. Discontinue use if batteries show signs of leakage, damage, or weakness at any time.
- Ensure the battery compartment is correctly and securely closed after installing the batteries.
- Wash hands after handling batteries.
- Disposable batteries are not rechargeable and must

be recycled or disposed of separately from household waste. Always dispose of batteries at an official collection point and according to your local environmental laws and guidelines.

### Specific Information Regarding R290 Refrigerant Gas









**⚠ WARNING: THE APPLIANCE MUST BE INSTALLED, OPERATED AND STORED IN A ROOM WITH A FLOOR AREA LARGER THAN 4M<sup>2</sup>.**

- This appliance contains 95g of R290 refrigerant gas.
- R290 is a refrigerant gas that complies with the European directive on the environment.
- Do not puncture any part of refrigerant circuit.
- Be aware R290 refrigerant is odourless and does not have the odour normally associated with natural gas and propane tanks.
- Do not use means to accelerate the defrosting process or to clean, other than those recommended by the manufacturer.
- The appliance must be placed in an area without any continuous sources of ignition such as open flames, gas, or electrical appliances in operation.
- Do not puncture and do not burn.
- If the appliance is installed, operated or stored in a non-ventilated area, the room must be designed to prevent the accumulation of refrigerant leaks resulting in a risk of fire or explosion due to ignition of the refrigerant caused by electric heaters, stoves, or other sources of ignition.
- The appliance must be stored in such a way as to

prevent mechanical failure.

- Individuals who operate or work on the refrigerant circuit must have the appropriate certification issued by an accredited organisation that ensures competence in handling refrigerants according to a specific evaluation recognised by associations in the industry.
- Maintenance and repairs that require the assistance of other qualified personnel must be performed under the supervision of an individual specified in the use of flammable refrigerants.

### SYMBOLS EXPLAINED

	For indoor use only.		Please read instruction manual and retain for future use.
	Equipment complies with the applicable UK safety requirements and regulations.		Equipment complies with the applicable EU safety requirements and regulations.
	<b>CAUTION:</b> This symbol shows that a service personnel should be handling this equipment with reference to the installation manual.		<b>CAUTION:</b> This symbol shows that information is available such as the operating manual or instruction manual.
	<b>WARNING:</b> The symbol shows that this appliance uses a flammable refrigerant. If the refrigerant leaks and is exposed to an external ignition source, there is a risk of fire.		

### SPECIFICATIONS

Model:	PB-AC08-UK	Product Dimensions:	310 x 682 x 302mm
Voltage:	220-240V~	Frequency:	50Hz
Rated Input Current:	2.5A	Cooling Capacity:	5000 BTU/H
Rated Power Input:	563W	EER:	2.60
Net Weight:	18kg	Gross Weight:	22kg
Refrigerant:	R290/95g		

### PARTS

1. Handle
2. Upper Air Inlet Grille & filters
3. Control Panel
4. Caster wheels [HYCC1]
5. Lower air inlet grille
6. Air Outlet Grille
7. Continuous drainage cap/  
continuous water outlet.  
Bottom drainage cap/  
bottom water outlet
8. Air Vent
9. 2\*AAA batteries +  
Remote Control
10. Square heat exhaust  
hose connector
11. Heat exhaust hose
12. Heat exhaust hose short connector
13. Window sealing board kit (Panel A&B + Clip)
14. 600mm water hose
15. Hinged window fabric sealing assembly
16. Sealing Velcro

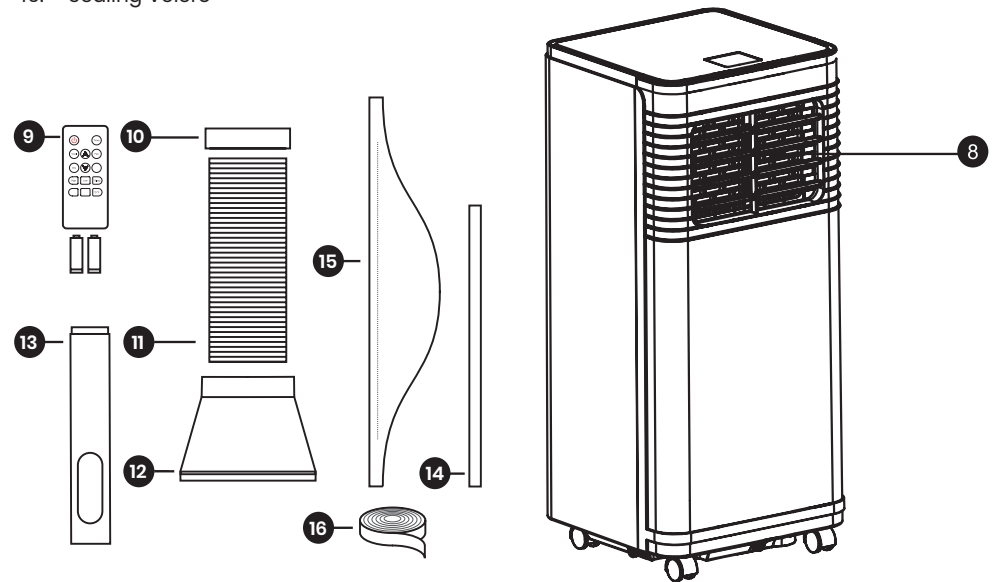
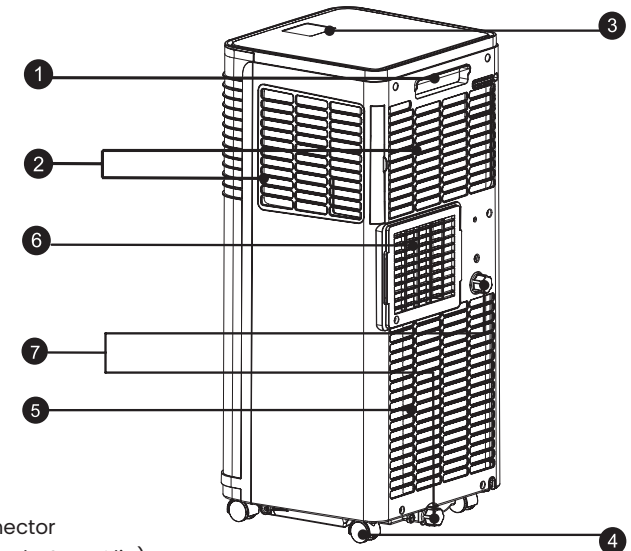

These images are for reference only, please refer to your product.

If you find you're missing any parts from your order, please contact our customer care team by emailing [help@probreeze.com](mailto:help@probreeze.com) for fast and friendly help.

To purchase additional filters, visit [www.probreeze.com/PB-AC08](http://www.probreeze.com/PB-AC08). If you have any questions or struggle to find the specific filter you need, please contact our customer care team for friendly and efficient help by emailing [help@probreeze.com](mailto:help@probreeze.com).

## CONTROL PANEL

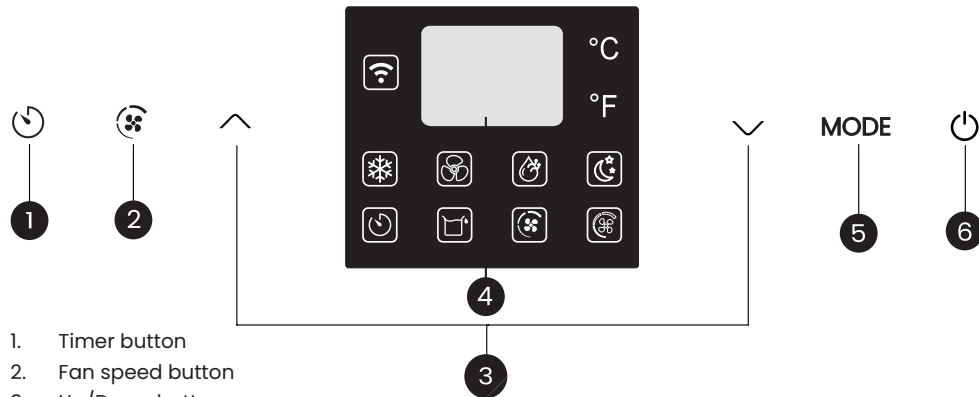

### Display Explained

1. Cool Mode
2. Fan Mode
3. Dry Mode
4. Sleep Mode
5. Timer active
6. Water tank full
7. High Fan Speed
8. Low Fan Speed

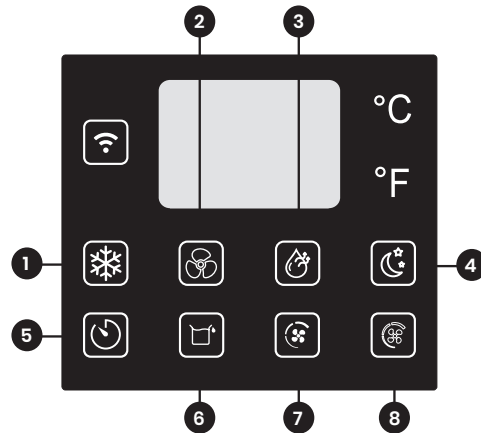

## Remote Control

1. Power button
2. Timer button
3. Cooling mode button
4. Fan-only mode button
5. Dry (Dehumidifying) mode button
6. Up/Down buttons
7. High fan speed button
8. Low fan speed button
9. Sleep mode button
10. Temperature unit button switch button

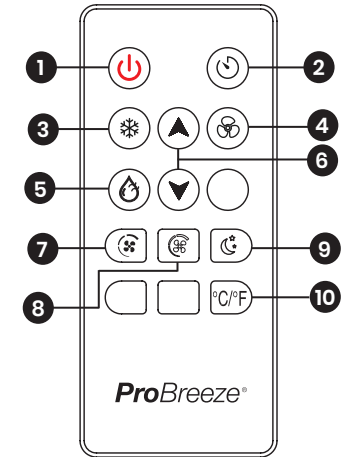

## INSTALLATION

Prior to and after installation adhere to the below:

1. When moving the appliance to the chosen location, ensure it is kept in an upright position.
2. Do not place or use the appliance, power cord, or any accessories in a bathroom, wet, or damp place.
3. Place the appliance on a flat and dry surface.
4. Keep it at least 50cm away from surrounding walls and/or objects.
5. Leave the appliance in an upright position for at least two hours before first use.
6. Keep the heat exhaust hose at least 90cm away from the floor.

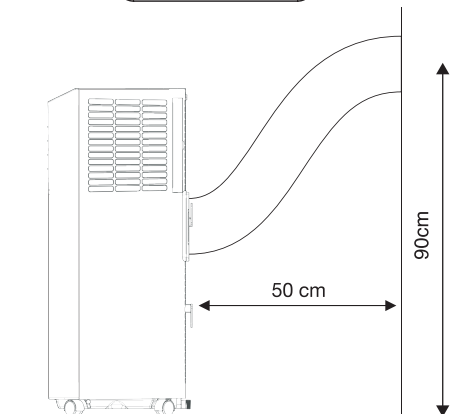

### Connecting the Exhaust Hose

In many ways, your new air conditioner is like a refrigerator, but instead of securing the cold air inside it blows the air around the room. Air conditioners utilise refrigerant gas to cool down warm air in a room and then blow the now-cooled air around the space with internal fans. They must vent the hot air outside (usually via a window, ventilation shaft, or dedicated passage) with an exhaust hose.

To connect your exhaust hose and other accessories, follow the instruction below:

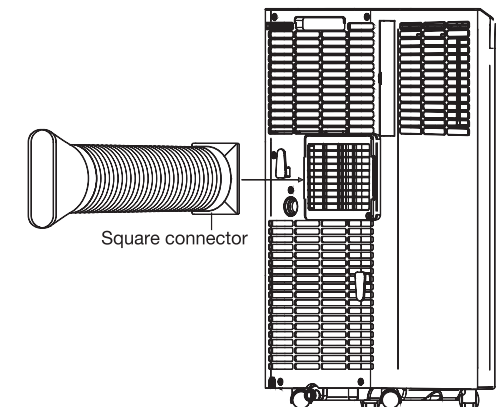

### Exhaust Hose Assembly

In this stage, you will be assembling the hose and will need...

- Square connector
- Heat exhaust hose
- Heat exhaust hose short connector

1. Rotate the square connector counterclockwise to lock it into the end of the heat exhaust hose.
2. Rotate the short connector counterclockwise to lock it into the end of the heat exhaust hose.

### Heat Exhaust Hose Installation

In this stage, you will need...

- Assembled heat exhaust hose
- Pro Breeze smart portable air conditioner

1. Slide the square connector onto the rear panel outlet situated on the back of your air conditioner. Ensure it is tightly secured in place.
2. When in Cooling Mode, position your air conditioner close to a window or door, with the hose outside, to allow the unit to vent the warm air out of the room. To seal your windows and doors, please see the installation instructions below.

### Sliding Windows Sealing Board Assembly Installation

If your windows slide open, please follow the below instructions:

#### You will need:

- Window sealing board kit (Panel A&B + Clip)
- Finished heat exhaust hose short connector

1. Insert Panel B into Panel A and adjust to the length or height of the window (see images)
2. Open your window and place the sealing board assembly into the open space.
3. Adjust to ensure an exact fit and secure with the clip.
4. Close the window to lock everything into place.
5. Attach the heat exhaust hose short connector to the elliptical hole.

The sealing board assembly is now ready for use.

#### Notes:

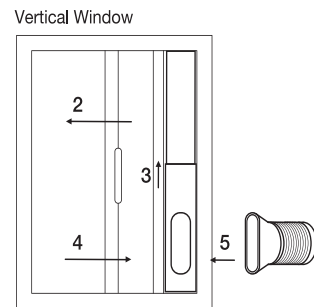
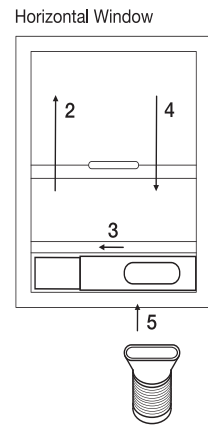
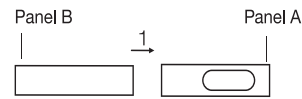

- If your window opening is smaller than the minimum length of the sealing board assembly trim to desired length using a hack saw.
- If your window opening is larger than the maximum length of the sealing board assembly use plywood or similar to fill the gap.

### Hinged Window Sealing Fabric Assembly Installation

If your window is hinged, follow the instructions below:

#### You will need:

- Hinged window fabric sealing assembly
- Sealing velcro
- A soft, clean cloth

**Step 1:** Open window and clean frame and casement surfaces of dust and particles.

**Step 2:** Stick the velcro tape around the entire window frame. **Never stick to the window seal as doing so will prohibit the window from closing fully.**

**Step 3:** Stick the velcro tape around the entire window casement (inside or outside). Check to ensure the window can close fully.

**Step 4:** Attach side A of the sealing fabric assembly to the velcro on the window frame working from the centre outwards.

**Step 5:** Close and open window to ensure no fabric gets trapped.

**Step 6:** Attach side B of the sealing fabric assembly to the velcro on the window casement working from the centre outwards.







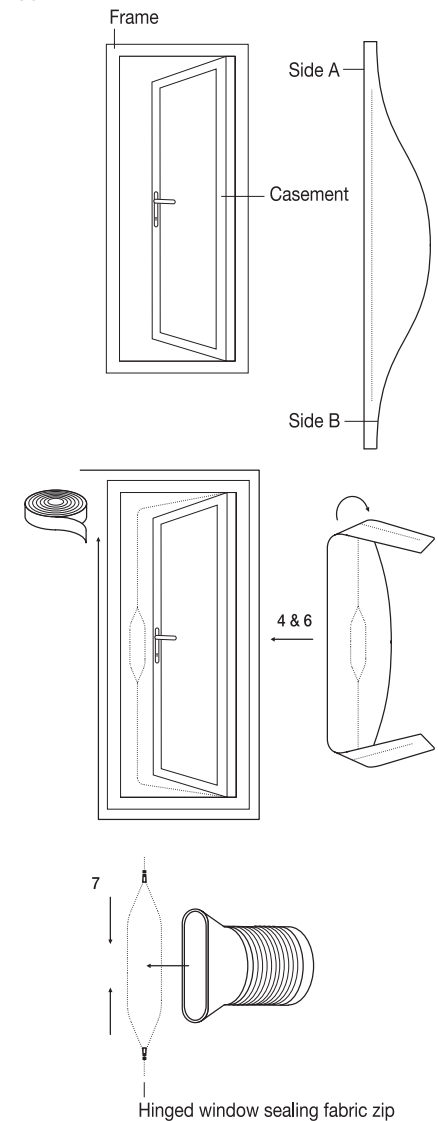

**Step 7:** Open the window slightly and insert the heat exhaust hose short connector into the sealing fabric assembly securing with the zippers around its lip.

The sealing fabric assembly is now ready for use.

**Scan for Full Video Instructions on How Best to Fit Your Hinged Door and Window Seals**



## OPERATING INSTRUCTIONS

	<b>Power button</b>	Press once to turn your device ON/OFF
	<b>Fan speed button</b>	Press to choose between high and low speed. <b>Note:</b> you cannot change the fan speed in dry mode
	<b>Up And Down Buttons</b>	Use the up and down buttons to: 1. Set desired temperature when in cooling mode. 2. Set desired hours until turn-on and turn-off when setting a timer. 3. Change between °C and °F by pressing both down at the same time.
<b>MODE</b>	<b>Mode button</b>	Press this button to change to one of the four modes outlined below. The relevant indicator will illuminate when the mode has been selected. <b>Note:</b> Temperature can only be set when in cooling mode.
	<b>Cooling Mode</b>	Perfect for cooling a room in hot weather. Use the up and down buttons when in cooling mode to set the desired temperature between 16°C (60°F) and 30°C (80°F). The appliance will cool the room if the room temperature goes above the set temperature. If the room temperature goes below the set temperature, cooling mode will pause, but the fan will remain operating at the set fan speed. <b>IMPORTANT: The heat exhaust hose must be connected to allow the hot air to be discharged outside. See instructions below.</b>
	<b>Fan-Only Mode</b>	The appliance operates at the set fan speed, blowing cold air into the room. The room temperature is displayed on the digital display panel. <b>Note: The heat exhaust hose does not have to be connected to the appliance.</b>
	<b>Dry (Dehumidifying) Mode</b>	Ideal for reducing room humidity in humid and damp times of year. The appliance will dehumidify the room if the room temperature is greater than or equal to 17°C (62°F) and the fan will operate at the low fan speed. If the room temperature decreases to less than or equal to 15°C (59°F) the appliance will stop dehumidifying the room, but the fan will continue to operate.
	<b>Sleep Mode</b>	Set sleep mode to reduce energy consumption when in cooling mode. To activate, press the sleep button on the remote control or both the timer and down buttons on the control panel at the same time. The display will blink five times with SL to confirm sleep mode has been set then revert to the set temperature. In sleep mode, after two hours the set temperature will increase automatically by 1°C (33°F). After another two hours, the set temperature will increase automatically by a further 1°C (33°F). and the fan speed will change to low fan speed if it is not already at this fan speed. The appliance will continue to run at this setting until turned off.
	<b>Timer Button</b>	you can set your device to turn on or off automatically in one hour increments (from 1-24hrs) using the timer button.

### Setting a Turn-On Timer

1. Ensure the appliance is plugged in and the power socket is turned on.
2. Press the timer button to activate the timer function.
3. Press the up and down buttons to set the desired time (1-24 hours) until turn-on.
4. The time digits will blink five times to confirm a timer has been set and the timer indicator light will remain illuminated.
5. Select the desired settings prior to turn-on.
6. To check the remaining time until turn on, press the timer button.
7. To cancel the turn-on timer, set the time to 0 hours or turn the appliance on and off.

**Note: If no desired settings are selected the appliance will turn on in the previously set settings.**

### Setting a Turn-Off Timer

1. Ensure the appliance is plugged in and the power socket is turned on.
2. Press the power button to turn the appliance on.
3. Press the timer button to activate the timer function.
4. Press the up and down buttons to set the desired time (1-24 hours) until turn-off.
5. The time digits will blink five times to confirm a timer has been set and the timer indicator light will remain illuminated.
6. Select the desired settings prior to turn-off.
7. To check the remaining time till turn- off press the timer button.
8. To cancel the turn-off timer set the time to 0 hours or turn the appliance off and on.

## WIFI AND SMART LIFE APP SET-UP

**Smart Life** is a centralised app for smart device management. With Smart Life, you can control your smart devices remotely and set up a complex chain of commands and automation. To connect your Pro Breeze smart air conditioner to a smartphone via Wi-Fi through the Smart Life app, follow the below steps.

**Note:** Ensure WiFi network is set to 2.4GHz.

- Download the Smart Life app by Tuya Inc from the Apple App Store or Google Play Store.
- Register for a Smart Life account.
- Log into the Smart Life app.
- On the Home page tap Add Device or the "+" symbol in the top right hand corner.
- Tap Large Home Appliances.
- Tap Air Conditioner.
- Plug in the appliance and ensure the power socket is turned on.
- Press the power button to turn on the appliance and then press the power button again to turn off the appliance and place it in standby mode.



- Press and hold the fan speed button for three seconds to activate the appliance's WiFi pairing function. After three seconds the WiFi indicator light will begin to blink.
- In the Smart Life app tap "Confirm WiFi Indicator Light Rapidly Blinking".
- Input your WiFi password and tap Confirm.
- The Smart Life app will automatically connect to the appliance and show Successfully Added Device.
- Return to the Smart Life app home page and tap the appliance's name.
- Use the controls to fully control the appliance and set desired settings etc.
- After successfully pairing your unit with the Smart-Life app, the air conditioner is ready to connect with Amazon Echo and Google Home (see below).

#### Notes:

- When the device is online, it can be controlled using the SmartLife app.
- When the device is offline, it displays "Offline" and can be remotely powered on.

#### Amazon Echo Set-Up

Before connecting the appliance to an Amazon Echo device via WiFi, ensure:

- The Smart Life app must have already been downloaded and the appliance successfully paired with the Smart Life app.
- The Amazon Alexa app must have already been downloaded.
- An Amazon Echo device must be paired with the Amazon Alexa app.

To connect Pro Breeze smart air conditioner to an Amazon Echo device via Wi-Fi through the Smart Life app follow the below steps.

##### 1. Link the Amazon Alexa app to the Smart Life app:

- **Step 1:** Open the Amazon Alexa app.
- **Step 2:** Go to Skills.
- **Step 3:** Search for Smart Life by Tuya Inc.
- **Step 4:** Tap Enable.
- **Step 5:** Follow the on-screen instructions to connect your Smart Life account with the Amazon Alexa app.

##### 1. Pair the Amazon Alexa app to the appliance:

- **Step 1:** Open the Amazon Alexa app.
- **Step 2:** Go to Devices.
- **Step 3:** Tap the "+" symbol to add a new device.
- **Step 4:** Tap the appliances name and follow the on-screen instructions to pair the Amazon Alexa app to the appliance.
- **Step 5:** Use Amazon Alexa to control the appliance e.g. "Alexa, turn on the air conditioner".

#### Google Home Set-Up

Before connecting the appliance to a Google Home device via Wi-Fi, ensure:

- The Smart Life app must have already been downloaded and the appliance successfully paired with the Smart Life app.
- The Google Home app must have already been downloaded.

- A Google Home device must be paired with the Google Home app.

To connect Pro Breeze smart air conditioner to a Google Home device, via Wi-Fi through the Smart Life app follow the below steps.

**Step 1:** Open the Google Home app.

**Step 2:** Tap the + symbol.

**Step 3:** Tap Set up device.

**Step 4:** Tap Have something already set up?

**Step 5:** Search for Smart Life by Tuya Inc.

**Step 6:** Follow the on-screen instructions to connect your Smart Life account with and the appliance to the Google Home app.

**Step 7:** Return to the Google Home screen.

**Step 8:** Tap the room assigned to the appliance and tap the appliance's name.

**Step 9:** Use Google Assistant to control the appliance e.g. "Hey Google, turn on the air conditioner."

## EMPTYING THE WATER TANK AND CONTINUOUS DRAINAGE

Your smart air conditioner also acts as a dehumidifier, extracting moisture from the surrounding air. This water is either stored in the water tank (and needs emptying) or can be automatically drained through the continuous drainage hose. For long-term use in humid or warm conditions, we recommend using the continuous drainage hose.

#### Instructions

When the water tank is full the warning FL will show on the display and the appliance will pause operation to prevent the water tank from overflowing.

 **WARNING: NEVER LEAVE WATER IN THE WATER TANK WHEN THE APPLIANCE IS NOT IN USE, MICROORGANISMS CAN GROW IN STAGNANT WATER, THE WATER TANK SHOULD BE EMPTIED AND CLEANED REGULARLY.**

To empty the water tank:

1. **Step 1:** Turn off the appliance and unplug it from the wall socket.
2. **Step 2:** Unplug and dismantle the air exhaust hose. Place a shallow tray underneath the water outlet.
3. **Step 3:** Unscrew the bottom drainage cap, unplug the drainage plug and allow the water to collect in the shallow tray. The water will automatically start to flow.
4. **Step 4:** To fully empty the water tank gently tilt the appliance back on its rear wheels. Do not tilt more than 30 degrees.
5. **Step 5:** Once empty, return the appliance to a fully upright position and replace the drainage plug and bottom drainage cap.
6. **Step 6:** Empty the shallow tray.

#### Connecting the Water Hose for Continuous Drainage

For long-term use, it is recommended to connect a water hose for continuous drainage.

To attach the water hose:

**Step 1:** Unscrew the continuous drain cap, unplug the drain plug, and store safely.

**Step 2:** Insert the water hose into the water outlet. Tightly secure in place.

**Step 3:** Feed the other end of the water hose to a suitable drainage outlet (e.g. a drain or bucket).

**Note:** When the appliance is set at a warm temperature it is recommended to attach the water hose as the water tank will fill at a faster rate than when set at a cold temperature.

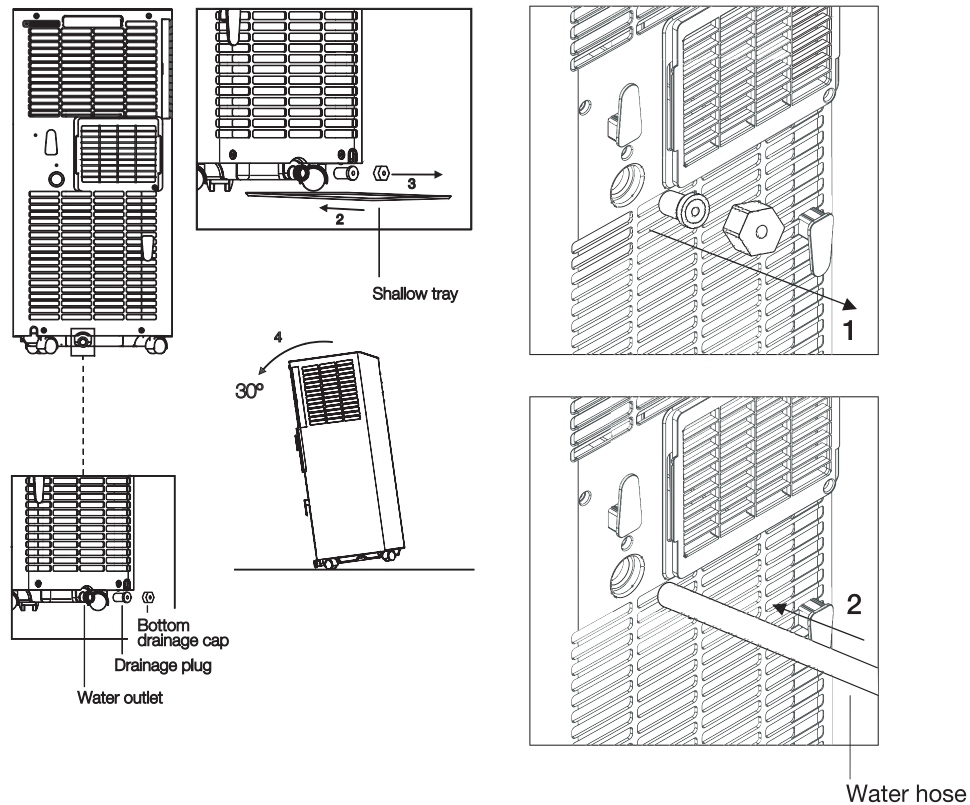

## CLEANING

**⚠ WARNING: NEVER LEAVE WATER IN THE WATER TANK WHEN THE APPLIANCE IS NOT IN USE, MICROORGANISMS CAN GROW IN STAGNANT WATER, THE WATER TANK SHOULD BE EMPTIED AND CLEANED REGULARLY.**

**⚠ CAUTION: DO NOT USE ANY ABRASIVE CLEANERS OR SOLVENTS, AS THIS WILL DAMAGE THE APPLIANCE. DO NOT ALLOW WATER OR OTHER LIQUIDS TO RUN INTO THE INTERIOR OF THE APPLIANCE, AS THIS COULD CREATE A FIRE AND/OR ELECTRICAL HAZARD.**

- Do not attempt to clean the appliance in any other way than that detailed by the manufacturer.
- Cleaning and user maintenance shall not be made by children.

### Exterior Cleaning:

- Clean the exterior surface of the appliance by wiping it with a soft, damp cloth. Dry the appliance with a soft, clean cloth.
- Clean the vents and openings of the appliance regularly with a vacuum cleaner, using the brush attachment to avoid any dust build-up.

**⚠ CAUTION: DO NOT OPERATE THE APPLIANCE WITHOUT THE FILTER. THIS WILL CAUSE IT TO CLOG UP WITH LINT AND DIRT AND WILL REDUCE PERFORMANCE. ALWAYS INSERT THE FILTER SECURELY.**

Clean the appliance's evaporator and condenser filter once every two weeks.

### To remove and clean the filters:

1. Grip the first filter by gripping the handle to the left of the upper air inlet grille and gently remove.
2. Upon removing the first filter the second filter handle will be exposed. Gently remove the second filter.
3. Use a firm brush and or vacuum cleaner to clean the filter of any dust and particles.
4. Return both the second filter and then the first filter to the upper air inlet grille.

## Heat Exhaust Pipe Cleaning

1. Remove the heat exhaust pipe from the rear of the appliance and the respective window sealing assembly. Allow to cool.
2. Use a soft, dry cloth to clean away any dust, or debris.
3. Return the heat exhaust pipe.

## STORAGE

### For long-term storage:

1. Empty the water tank and leave both the continuous and bottom drainage caps and drainage plugs off and unplugged.
2. Run the appliance in fan-only mode on the low fan speed setting for 12 hours to allow the interior of the appliance to fully dry.
3. Turn off the appliance, replace both the continuous and bottom drainage caps and drainage plugs, and unplug the power cord.
4. Remove the heat exhaust hose.
5. Remove the batteries from the remote control.
6. Ensure the appliance and water tank are clean and dry before storage.
7. Do not kink or wrap the power cord and plug around the appliance, as this may cause the insulation to weaken or split, particularly where it enters the appliance.
8. Store the appliance in a safe, clean and dry place, away from direct sunlight and out of reach of children when not in use. To store your product, we recommend using the original or a similar sized box.

## SAFETY FEATURES

### Anti-Frost Protection

If the internal pipe temperature drops too low the unit will pause. The display will show E4 and the appliance will initiate anti-frost protection rendering the control panel buttons inactive, apart from the power button. Once the internal pipe temperature has warmed to above 8°C (46.4°F) the anti-frost protection will cease, and the appliance will return to operating at the chosen settings.

### Compressor Delay Protection

To protect the compressor, apart from when the appliance and compressor are activated for the first time after being turned on via the power button, there will be a three-minute delay between every occurrence of the compressor turning off and on.

## TROUBLESHOOTING

Please contact a professional serviceman without delay in the following situation.

**Note: when abnormal situations occur, turn off the machine and pull out the plug, then contact with a professional electrician for help.**

Problem	Cause	Solution
The unit doesn't work	No display	Reset the circuit breaker on the Units cord
	The Full Water Tank symbol is lit. Or the display panel displays "FL"	Turn the power off and unplug the unit, then drain the water tank with the method outlined in this manual. Plug the unit back in
	Time OFF function has started	The unit can be restarted three minutes after being turned off
The unit starts frequently	Direct Sunlight	Move the unit out of direct sunlight
	Doors and windows are open/ there are many heat sources in the room	Close doors and windows and remove heat sources
	The filter screen is dirty	Clean the filter screens or replace them
	The Air inlet or air outlet is blocked	Remove the blockage
Loud noise coming from the unit	The machine is not put on flat ground	Place it on flat and stable ground
The compressor doesn't work	Compressor time-delay protection turns	Wait for three minutes, then restart the machine after the temperature reduces

## ERROR CODES



—

Error code	Problem
E1	Error of the coil's temperature sensor
E2	Error of the indoor temperature sensor
E3	Anti-freezing protection: temperature of the coil is too low and the whole unit is off. When temperature exceeds 8°C (46.4°F) the protection is released, and the previous working state is recovered

## RECYCLING AND DISPOSAL

—

Waste electrical and electronic products (WEEE), batteries, accumulators, and packaging should not be disposed of with general household waste. This is to prevent possible harm to the environment and human well-being, and to help conserve our natural resources. Most electrical products with a plug, battery, or cable can be recycled. Contact your local council, household waste disposal service, or the store where you purchased the product for information regarding the collection schemes in your area.

	<b>Waste Electrical and Electronic Equipment (WEEE)</b>	This symbol on the product and/or packaging indicates that Waste Electrical products (WEEE) under Directive 2012/19/EU which governs used electrical and electronic appliances, should not be disposed of with general household waste.
	<b>Waste Batteries and Rechargeable Batteries</b>	This symbol on the batteries supplied with your product indicates that Waste Batteries under Directive 2006/66/EC which governs used batteries and accumulators should not be disposed of with general household waste. If the battery contains more than 0.004% lead, the battery symbol will be accompanied by the letters (PB).
	<b>The Mobius Loop</b>	This symbol indicates that the product or packaging is capable of being recycled.

### Take-Back Scheme

Waste electrical products (WEEE) can be sent to One Retail Group for recycling and disposal when you purchase a new product from One Retail Group, on a like-for-like basis. For more information on how to recycle this product please visit [www.probreeze.com](http://www.probreeze.com)

The end-user of electrical and electronic products (WEEE) is responsible for separating old batteries and lamp bulbs before they are handed over to a designated disposal and recycling service. Waste batteries can also be disposed of in collection bins, which can be found in most local supermarkets and household waste recycling centres.

### Personal Data Protection

Electrical and electronic products (WEEE) may contain personal user data, depending on the type of product. This may include app-linked products that connect to wifi. The end-user is responsible for deleting the data on the waste electrical and electronic products prior to disposal.

## DECLARATION OF CONFORMITY

—

Hereby, One Retail Group Limited declares that the radio equipment type PB-AC08-UK is in compliance with Directive 2014/53/EU/ Radio Equipment Regulations 2017. The full text of the EU Declaration of Conformity / UK Declaration of Conformity is available at the following internet address: <https://probreeze.com/ec-delcaration-of-conformity/>



[www.probreeze.com](http://www.probreeze.com)

One Retail Group, Ryland House,  
24a Ryland Road, London, NW5 3EH, United Kingdom

EU Authorised Representative: Brandrep Limited, The Black Church,  
St Mary's Pl N, Dublin, D07 P4AX, Ireland

© Copyright 2023