

# phantomSchwank STP Series Outdoor Tube Heaters

# phantomSchwank STP Series

## Outdoor Tube Heaters

LOW INTENSITY TUBE HEATER - OUTDOOR

CSA/ANSI Z83.26:20 • CSA 2.37:20

---

# INSTALLATION/ OPERATION MANUAL

---



## WARNING



FOR OUTDOOR USE ONLY.

Improper installation, adjustment, alteration, service or maintenance can cause property damage, injury or death. Read the installation, operating and maintenance instructions thoroughly before installing or servicing this equipment.



### **SAFETY ALERT:**

Do not store or use gasoline or other flammable vapours and liquids in the vicinity of this or any other appliance.



### **IF YOU SMELL GAS:**

- Shut off gas to the appliance.
- Extinguish any open flame.
- If odor continues, keep away from the appliance and immediately call your gas supplier or fire department.

---

### FIELD CONVERTIBILITY:

This appliance is field convertible to LP gas. Only use a kit available from manufacturer. Follow instructions provided in the kit and all local and national codes.

***Keep this manual in a secure place .***

***Record for future reference:***

Model #: \_\_\_\_\_

Serial #: \_\_\_\_\_

**NOTICE:**

*This manual is current and correct for this product at time of manufacture. Occasional revision of the product and/ or Certification Standard may require changes to the product and/or this manual.*

*This publication, or parts thereof, may not be reproduced in any form, without prior written consent from The Manufacturer. Unauthorized use or distribution of this publication is strictly prohibited.*

**Schwank**

*5285 Bradco Boulevard  
Mississauga, Ontario L4W 2A6*

*2 Schwank Way  
Waynesboro, Georgia 30830*

**Customer & Technical Services**

*Phone: 877-686-3779*

*Fax: 866-361-0523*

*e-mail: [csr@schwankgroup.com](mailto:csr@schwankgroup.com)*

**[www.schwankgroup.com](http://www.schwankgroup.com)**

# phantomSchwank STP Series

## Table of Contents

TOPIC	PAGE
APPLICATION	5
1 SPECIFICATIONS AND DIMENSIONS	6
2 MINIMUM CLEARANCE TO COMBUSTIBLES	7
3 PRE INSTALLATION SURVEY	9
4 MOUNTING	9
5 UNPACK THE BOXES	12
6 UNIT ASSEMBLING AND INSTALLATION	14
7 GAS SUPPLY - FLEXIBLE GAS CONNECTION	19
8 ELECTRICAL WIRING	22
9 OPERATION	24
10 TROUBLE SHOOTING	29
11 START-UP / COMMISSIONING SHEET	32
WARRANTY STATEMENT	BACK PAGE



## WARNING

For OUTDOOR USE ONLY.



Improper installation, adjustment, alteration, service or maintenance can cause property damage, injury or death. Read and understand this installation and operation manual thoroughly prior to assembly, installation, operation or service to this appliance. This heater must be installed and serviced only by a trained gas service technician.



Do not store or use gasoline or other flammable vapours and liquids in the vicinity of this or any other gas fired appliance. Failure to comply could result in personal injury, death, fire and/or property damage.



Do not store or use gasoline or other flammable vapours and liquids in the vicinity of this or any other gas fired appliance.



### WARNING

California Proposition 65:

This product can expose you to chemicals including carbon monoxide, which is known to the State of California to cause birth defects or other reproductive harm. For more information, go to [www.P65Warnings.ca.gov](http://www.P65Warnings.ca.gov).

### APPLICATION

This heater is approved for OUTDOOR INSTALLATION ONLY.

This heater is not for installation in a Class 1 or Class 2 explosive environment, nor in a residential dwelling.

A “residential dwelling” is defined in the standard as “a housekeeping unit used or intended to be used as a domicile by one or more persons, containing cooking, eating, living, sleeping, and/or sanitary facilities. A

residential dwelling does not include an attached garage, detached garage, workshop or outdoors”. Local Code requirements take precedence for this application.

Installation of a gas fired tube heater must conform to all heating installation design procedures including clearance to combustibles, and connection to the gas and electrical supplies.

If installation of this equipment is in question, consult with the local authority having jurisdiction (Fire Marshall, labor department, insurance underwriter, or other). Revisions to codes and/or standards, may require revision to equipment and installation procedures. In case of discrepancy, the latest codes, standards, and installation manual will take priority over prior releases.

## APPLICATION

INSTALLATION AS AN OUTDOOR PATIO HEATER. What is “Outdoor”? An appliance approved for “outdoor use” may be installed with shelter no more inclusive than:

- With walls on all sides, but with no overhead cover, (overhead permanently open) or
- Within a partial enclosure which includes an overhead cover and no more than two side walls. These side walls may be parallel, as in a breezeway, or at right angle to each other. The open sides must be permanently open or
- Within a partial enclosure which includes an overhead cover and three side walls, as long as 30 percent or more of the horizontal periphery of the enclosure is permanently open. If these “outdoor” conditions are not met, the appliance is approved for “indoor use” and ventilation requirements of local codes apply.

## 1. TABLE 1: SPECIFICATIONS AND DIMENSIONS

MODEL	FUEL TYPE	INPUT RATING (BTU/H)		OVERALL LENGTH (FT)	Material: Housing	Weight (lbs)*	Conversion Kit Part Number
		HIGH	LOW				
STP-TA05-10-BN	NG	50,000	35,000	12	Marine-Grade Aluminum	95	JS-0554-LL-TP
STP-TA08-10-BN	NG	80,000	60,000	12		96	JS-0554-NL-TP
STP-TA11-15-BN	NG	115,000	80,000	17		127	JS-0554-PL-TP

Note: Conversion kit is available to convert standard NG heater to LP model.  
\*Approximate gross shipping weight.

**FIGURE 1 HEATER DIMENSIONS**

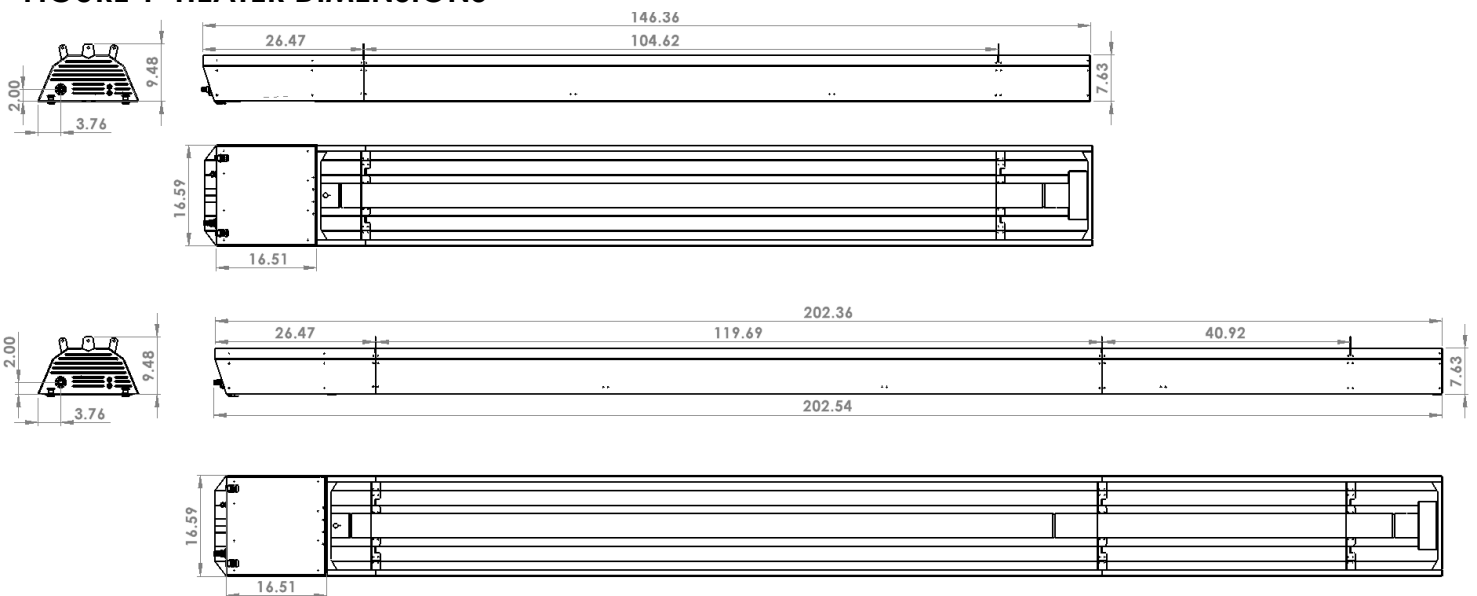

**Note: Eggcrate grilles not shown in the dimension drawings for better demonstration purpose.**

## 2. FIGURE 2 MINIMUM CLEARANCES TO COMBUSTIBLES - refer to Table 2 for values

**NOTE:** A 'PEEL & STICK' SIGN IS SUPPLIED: USE AN INDELIBLE MARKER TO ENTER VALUES 'H', 'S', 'F', & 'B' ON THE SIGN.



POST THE SIGN ADJACENT TO THE HEATER THERMOSTAT OR IN A PROMINENT LOCATION.

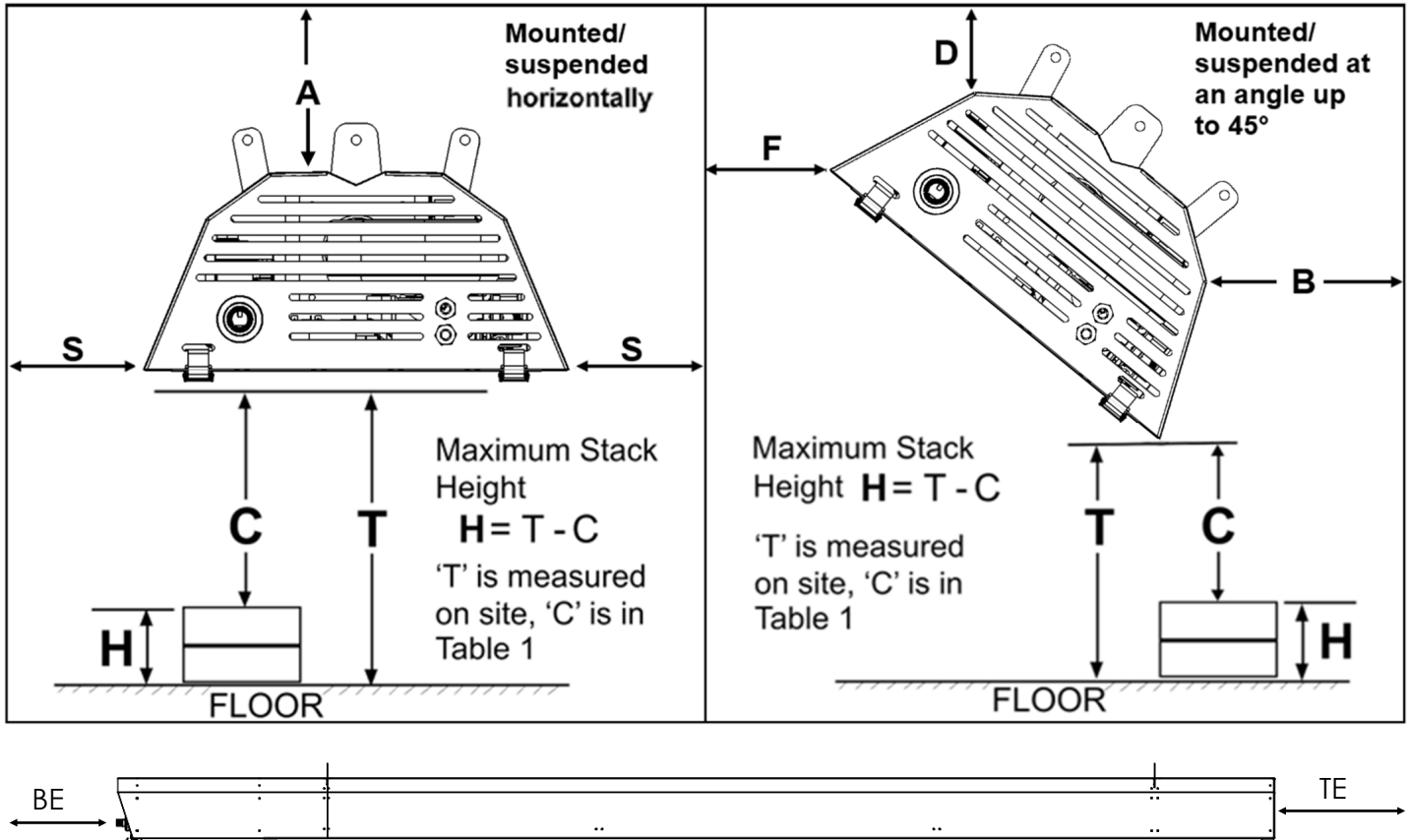

**TABLE 2 MINIMUM CLEARANCES TO COMBUSTIBLES**

MODEL Input Rate (BTU/h)	SUSPENDED HORIZONTALLY			SUSPENDED AT AN ANGLE UP TO 45 DEGREE				BURNER END	TUBE END
	A inches	S inches	C inches	D inches	B inches	F inches	C inches	BE inches	TE inches
50,000	4	20	42	4	3	40	44	24	48
80,000	5	24	62	5	3	54	60	24	48
115,000	5	26	74	5	3	62	70	24	48

**NOTE:** That in the above table the Clearances are measured from the reflector.

The clearance to combustible materials represents the minimum distance that must be maintained between the heater and a nearby surface. **The stated clearance to combustibles represents a surface temperature of 90F° (50°C) above room temperature.**

**It is the installer's responsibility to ensure that building materials with a low heat tolerance which may degrade at lower temperatures are protected to prevent degradation.** Examples of low heat tolerance materials include vinyl siding, fabrics, some plastics, filmy materials, etc.



**WARNING**

In locations used for the storage of combustible materials: Signs must be posted specifying the *maximum permissible stacking height* to maintain the required clearances from the heater to the combustibles.

The signs must be posted either adjacent to the IR heating system thermostats or in the absence of such thermostats, in a conspicuous place.

**A “peel and stick” sign is provided with this heater (look in manual). Use a permanent marker to record the required dimensions on the sign for the heater model installed.**

To calculate the value 'H': ( $H = T - C$ )

- Measure the on site distance between bottom of the heater and the floor = 'T' inches.
- Refer to Table 1 to get the value 'C' that corresponds to the model you are installing
- Subtract the clearance below the heater 'C' from 'T' to get value 'H'.
- Enter this value 'H' on the sign.

Refer to the information in Figure 2 and Table 2

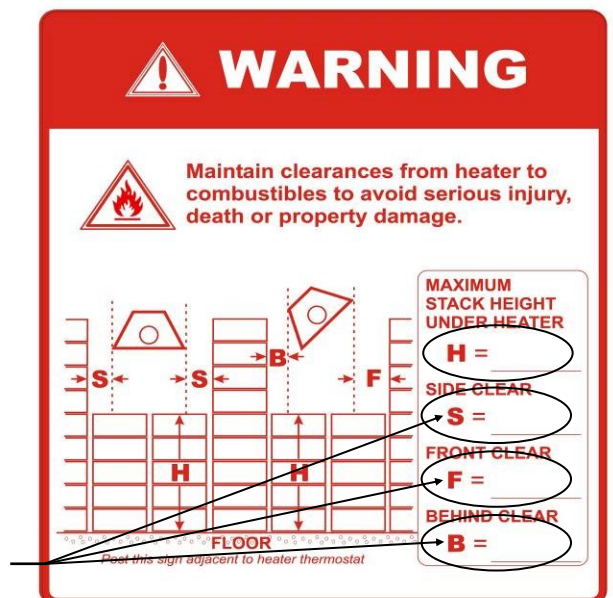

*Post this sign as instructed above.*



### 3. PRE INSTALLATION SURVEY

It is recommended that a full heating design be conducted on the structure or area to be heated. Heater sizing and placement must consider available mounting height, and the certified clearances to combustibles with respect to stored material, moveable objects, sprinkler system heads, and other obstructions on the site.

Installation must conform with all local codes or, in the absence of local codes, with the latest edition of the National Fuel Gas Code, NFPA 54/ ANSI Z223.1 in the USA. or the Natural Gas and Propane Installation Code, CSA B149.1 in Canada. The latest edition of National Electrical Code ANSI/ NFPA 70 in the United States and Canadian Electrical Code CSA C22.1 in Canada must also be observed.

The heating system must have gas piping of the correct diameter, length, and arrangement to function properly. For this reason, a layout drawing is necessary.

### 4. MOUNTING

This heater must be mounted with at least the minimum clearances between the heater and combustibles as shown in Figure 2 and Table 2. It is the installer's responsibility to ensure that building materials with a low heat tolerance which may degrade at lower temperatures are protected to prevent degradation. Examples of low heat tolerance materials include vinyl siding, fabrics, some plastics, filmy materials, etc.

Positioning of lights, sprinkler heads, overhead doors, storage areas, gas and electrical lines, parked vehicles, cranes and any other possible obstruction or hazard must be evaluated prior to installation.

**Ensure adequate clearance around the air intake at the burner to allow sufficient combustion air supply to the heater.**

Guidelines for heater placement refer to Table 3.

**TABLE 3: GUIDELINES FOR HEATER PLACEMENT**

MODEL HIGH INPUT (BTU/H)	TYPICAL MOUNTING HEIGHT* ft	MAXIMUM DISTANCE BETWEEN HEATERS	DISTANCE BETWEEN OUTSIDE WALL AND PARALLEL HEATER LONG AXIS	
			HORIZONTAL ft	ANGLE
50,000	8 – 13	20	8 – 12	Combustible Clearance "B" (refer to Table 2)
80,000	9 – 15	30	12 – 16	
115,000	10– 17	35	13 – 18	

\* TYPICAL MOUNTING HEIGHT provides optimum comfort in general space heating applications. Variance from the typical height can occur in applications:

- Higher mounting heights due to structure or application requirements
- Lower mounting heights for area or 'spot' heat, or in areas with greater air movement / infiltration losses (near overhead doors, etc.)
- Lower mounting height when the diagonal distance from a heater to personnel provides a distance value similar to the Typical Mounting Height

**IMPORTANT:** Single or multiple heater placement must be such that continuous operation of heater (s) will not cause combustible material or materials in storage to reach a temperature in excess of ambient temperature plus 90°F (50°C).



**It is the installer's responsibility to ensure that building materials with a low heat tolerance which may degrade at lower temperatures are protected to prevent degradation. Examples of low heat tolerance materials include vinyl siding, fabrics, some plastics, filmy materials, etc.**

**TABLE 4: AVAILABLE MOUNTING BRACKETS (ORDER SEPERATELY)**

Angle	Mounting	Bracket	Overall Dimension after mounting
0 degree	Ceiling Mount		
30 degree	Ceiling Mount/ Wall Mount		
45 degree	Ceiling Mount/ Wall Mount		

Unit can be also hung by chain, cable, and/ or other hardware, with minimum rating load at 100 lbs (45.5 kg).

Tube **MUST** be allowed to expand and contract within the restrained hanger system. It is recommended to install the longitudinal restraint at the first hanger from burner end, and the lateral restraint at the end hanger from tube end.

In areas prone to earthquake, or as specified on a project, install lateral and longitudinal seismic restraints as indicated in Figure 3. If the heater location can be impacted by wind (outdoors, aircraft hangars, etc) refer to Figure 4.

These restraint systems indicate typical suspension of and attachment to the heater. Attachment of suspension hardware to the structure will be as required by site structural conditions, installation codes, and/or local engineering design requirements. Other material or systems of restraint may be specified by local or national codes, or by project engineering specifications.

Any and all other required seismic mounting hardware is field supplied by the installer.

**FIGURE 3**

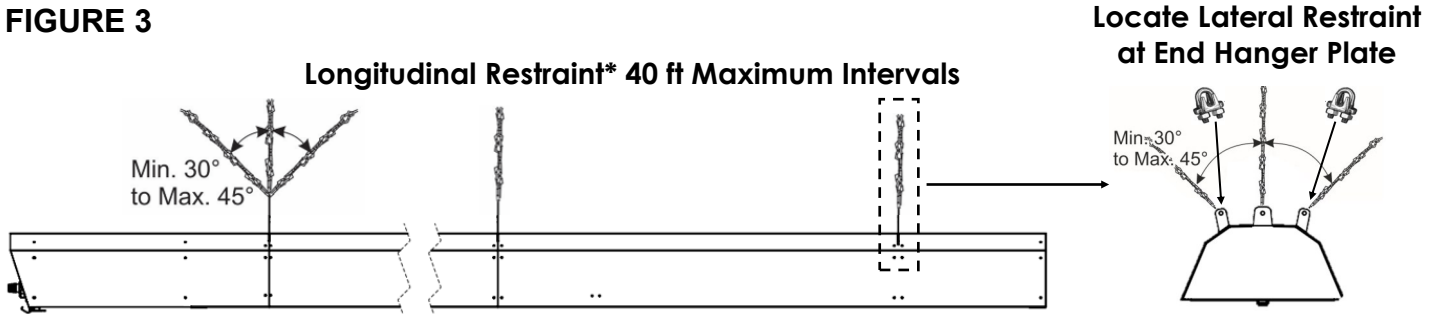

**HIGH WIND RESTRAINT GUIDELINES - LATERAL, LONGITUDINAL, AND VERTICAL**

In areas with wind conditions (outdoors, near large doors, etc) in addition to lateral and longitudinal restraint the heater must be restrained from vertical movement. Suspend the heater using 3/8" threaded rod with 3" adjustment turnbuckle through a safety ring at each hanger location.

**FIGURE 4**

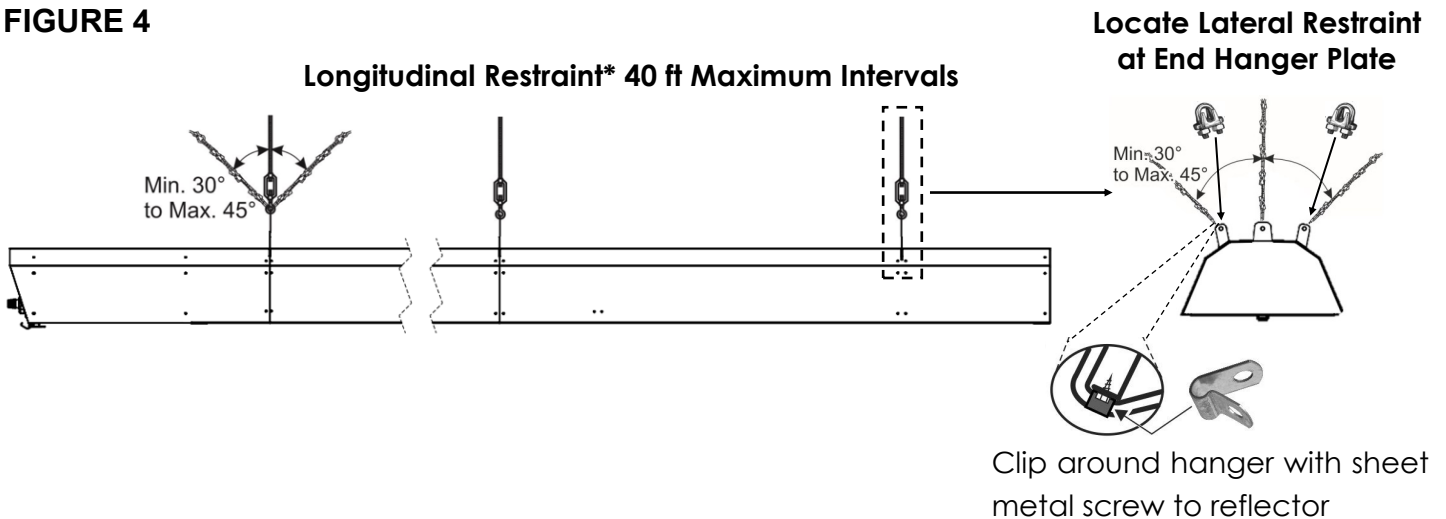

## 5. UNPACK THE BOXES

### STP-TA05-10-BN & STP-TA08-10-BN

Box 1

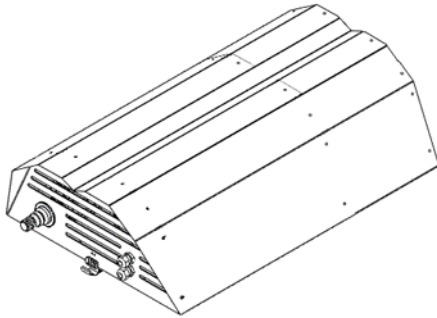

Box 2

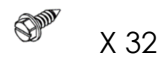
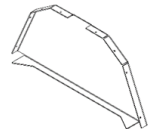
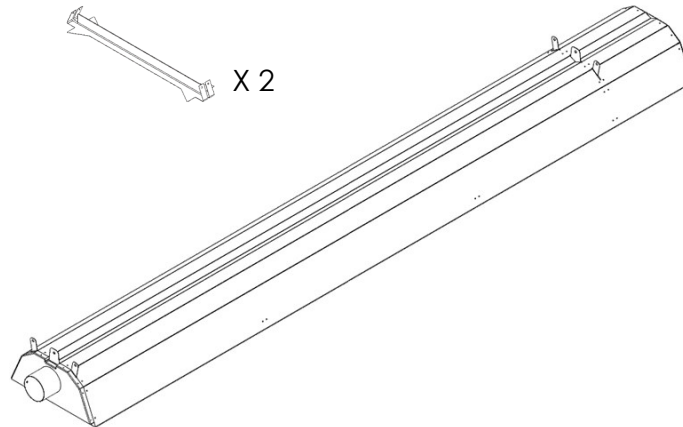
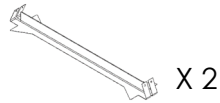
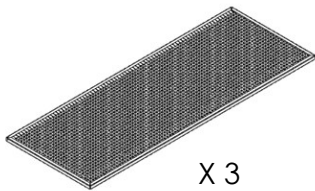

# 5. UNPACK THE BOXES

## STP-TA11-15-BN

Box 1

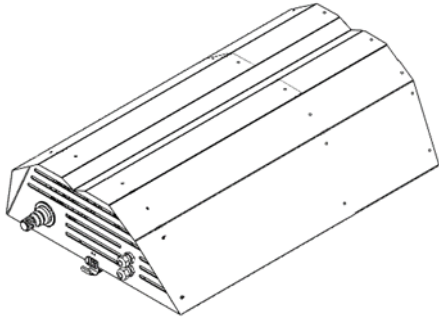

**Schwank** 

STP SERIES

**phantomSchwank Tube Heaters**

LINE NUMBER: 001-06-0000 - C00000  
 REVISION: 001-06-0000-01  
 CHANGEM: 001-06-0000 - C000 2.07.00

**INSTALLATION / OPERATION MANUAL**

**WARNING**

**FOR OUTDOOR USE ONLY**  
 This heater is designed for outdoor use only. It is not to be used indoors. Do not use this heater in any area where it could be a fire hazard. Do not use this heater in any area where it could be a fire hazard. Do not use this heater in any area where it could be a fire hazard.

**SAFETY ALERT**  
 Do not touch or use gasoline or other flammable vapors and fumes in the vicinity of this unit or the heater.

**DISASSEMBLY**  
 • Turn off gas to the appliance.  
 • Disconnect the unit from the gas supply.

**WARRANTY INFORMATION**  
 The heater is warranted for 5 years. See the warranty card for details. For more information, contact the manufacturer.

**See the manual for further information.**

Box 2

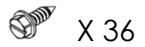
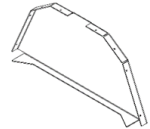
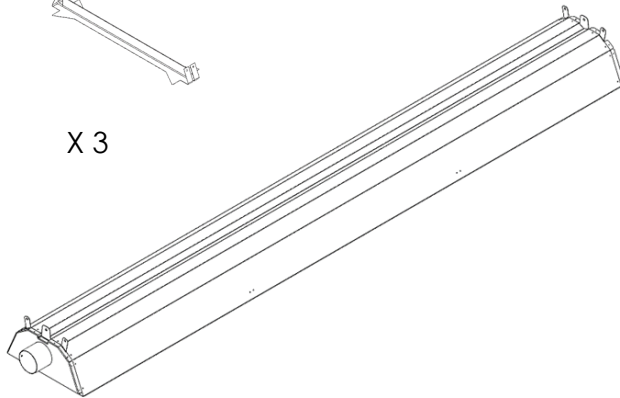
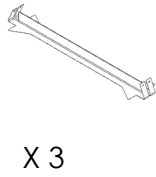
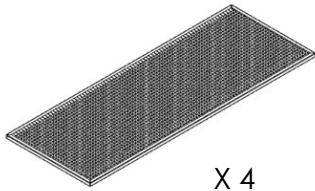

Box 3

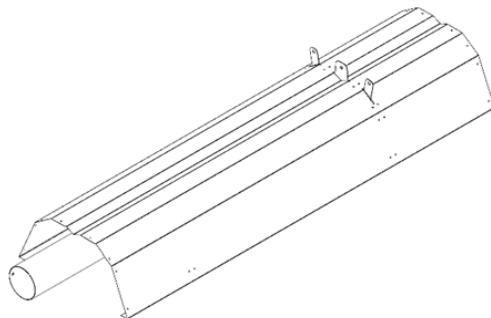

## 6. UNIT ASSEMBLING AND INSTALLATION

### STP-TA05-10-BN & STP-TA08-10-BN

#### Step 1

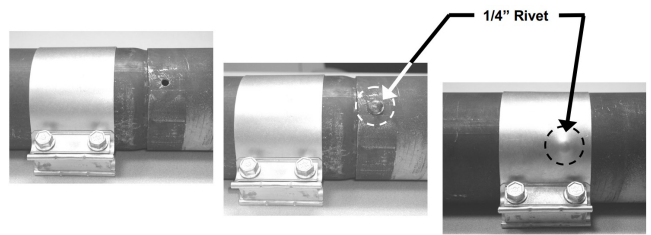
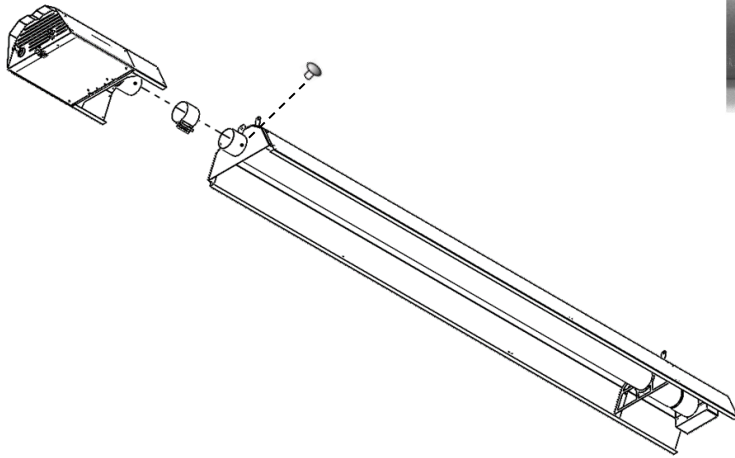

Slide the coupler across the center of the joint. Torque nuts to 40 lb-ft



#### Step 2

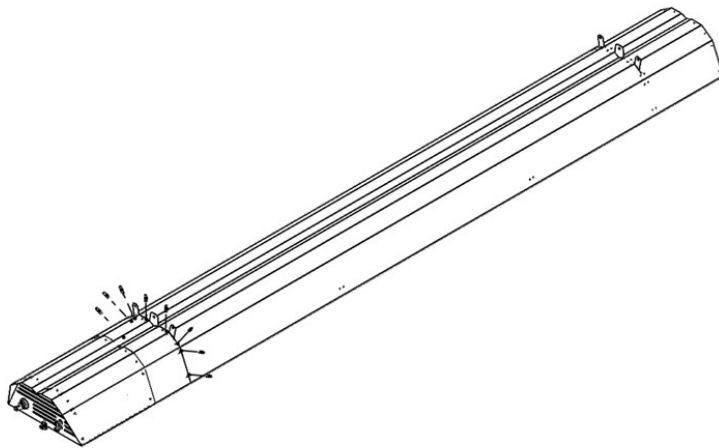

 X 8

#### Step 3

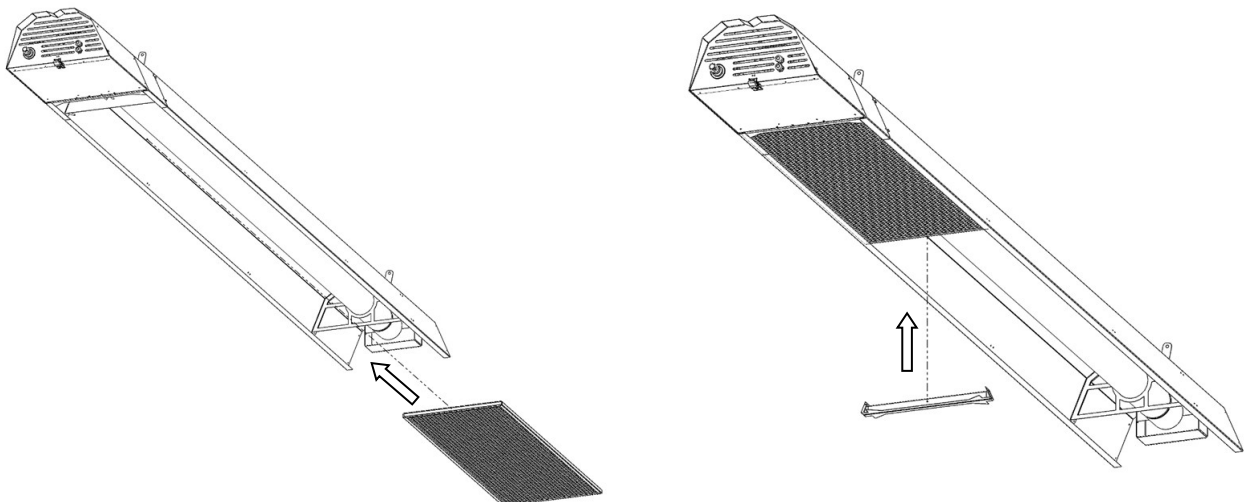

## 6. UNIT ASSEMBLING AND INSTALLATION

### STP-TA05-10-BN & STP-TA08-10-BN

Step 4

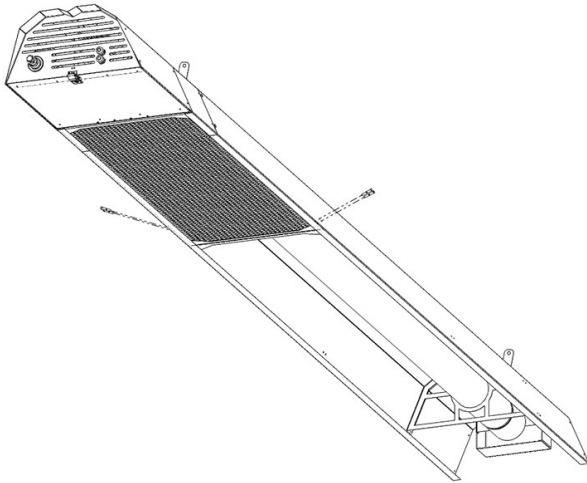

 X 4

Step 5

Repeat Step 3 and Step 4 for the second and third decorative grilles and the second retaining bracket.

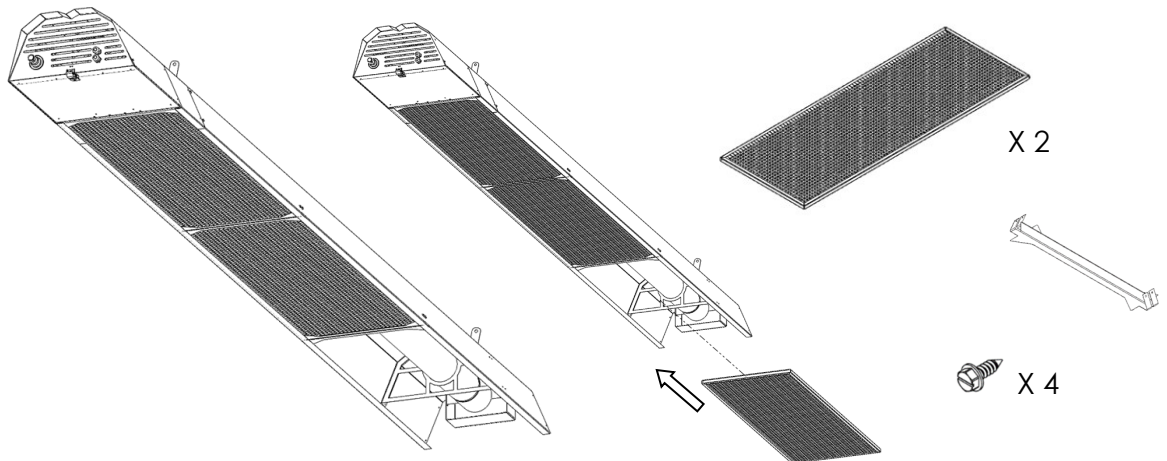

X 2

 X 4

Step 6

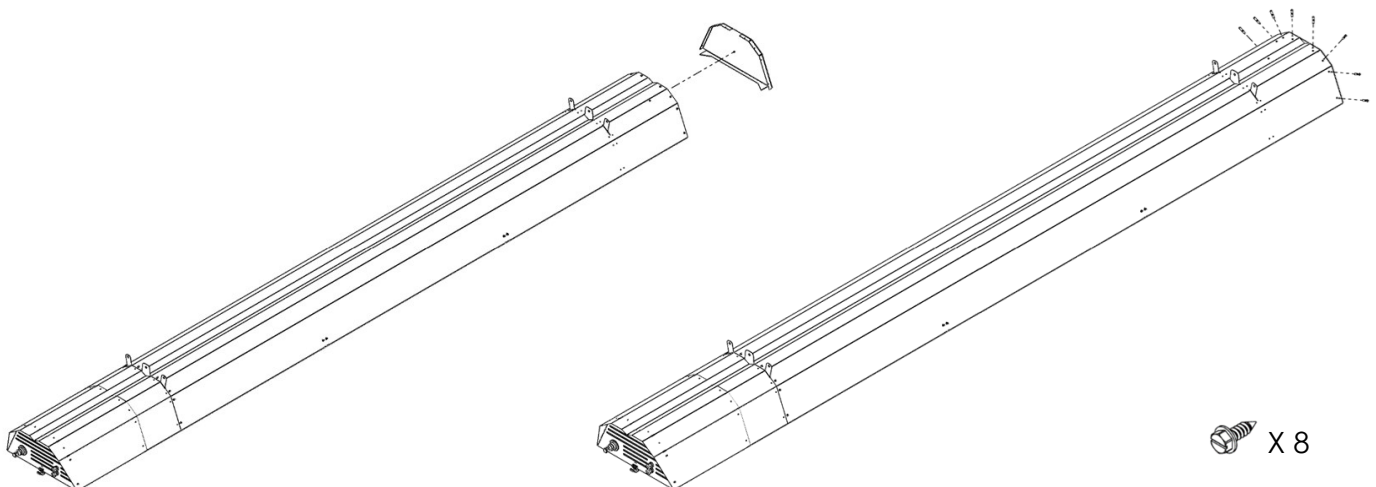

 X 8

## 6. UNIT ASSEMBLING AND INSTALLATION

### STP-TA11-15-BN

Step 1

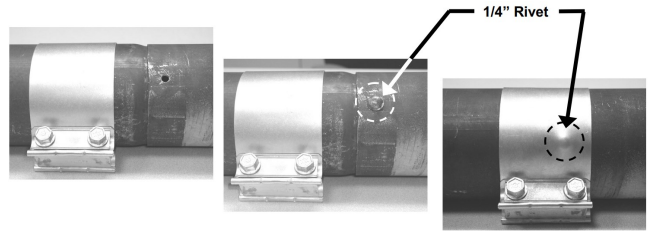
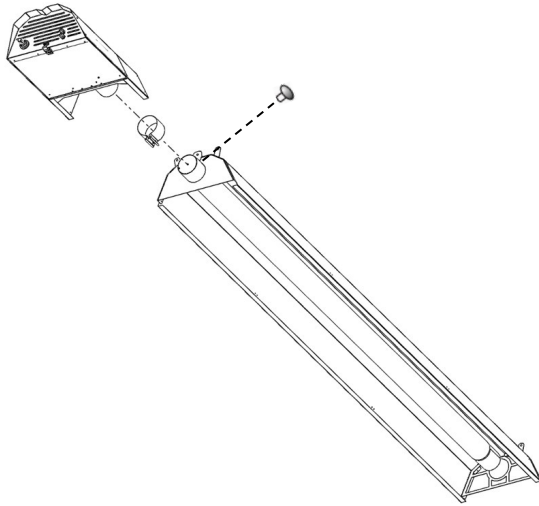

Slide the coupler across the center of the joint. Torque nuts to 40 lb-ft



Step 2

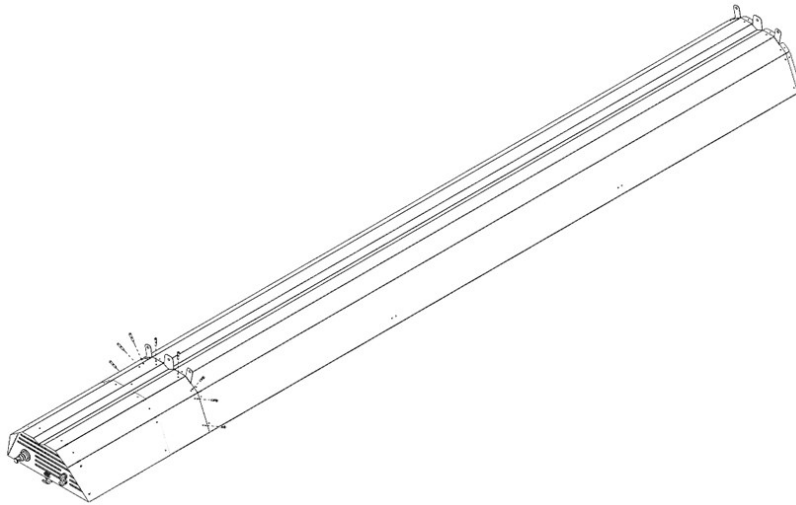

 X 8

Step 3

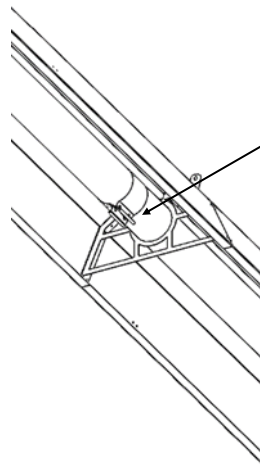
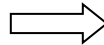
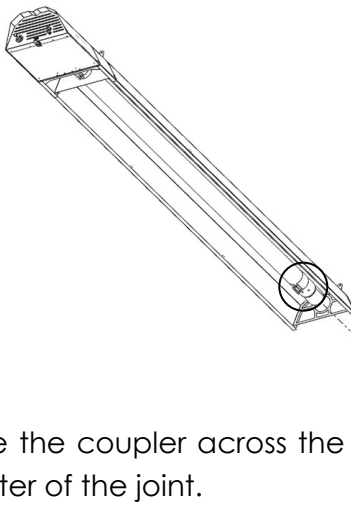

Torque nuts to 40 lb-ft

Slide the coupler across the center of the joint.



## 6. UNIT ASSEMBLING AND INSTALLATION

### STP-TA11-15-BN

Step 4

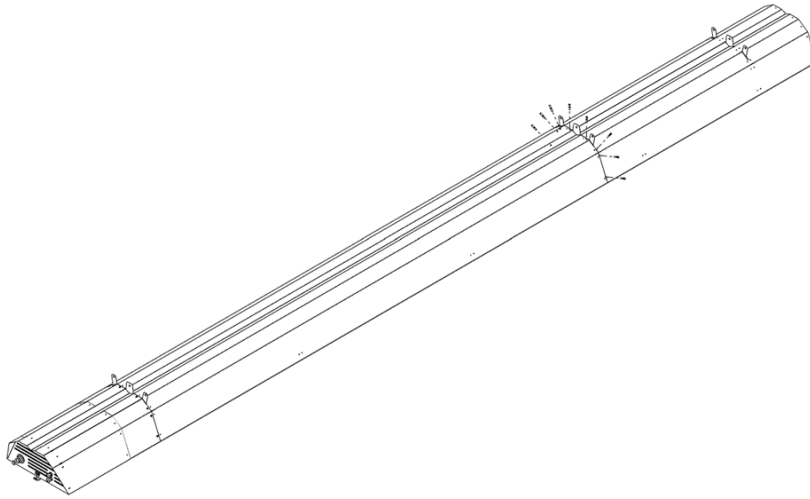

 X 8

Step 5

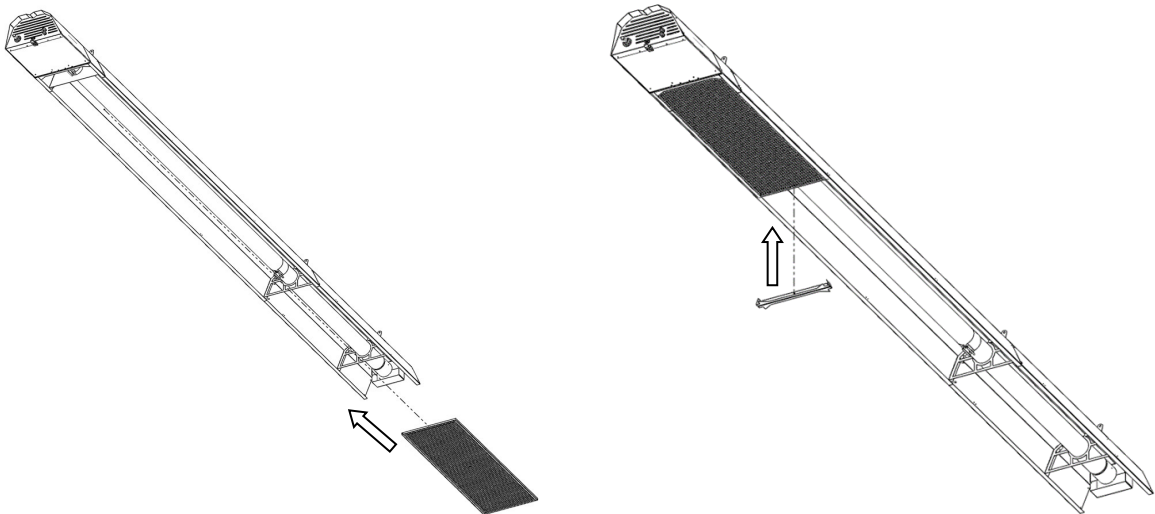

Step 6

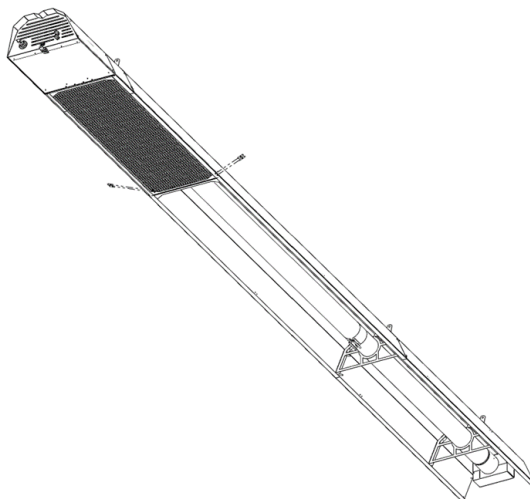

 X 4

## 6. UNIT ASSEMBLING AND INSTALLATION

### STP-TA11-15-BN

#### Step 7

Repeat Step 4 and Step 5 for the rest decorative grilles and retaining brackets.

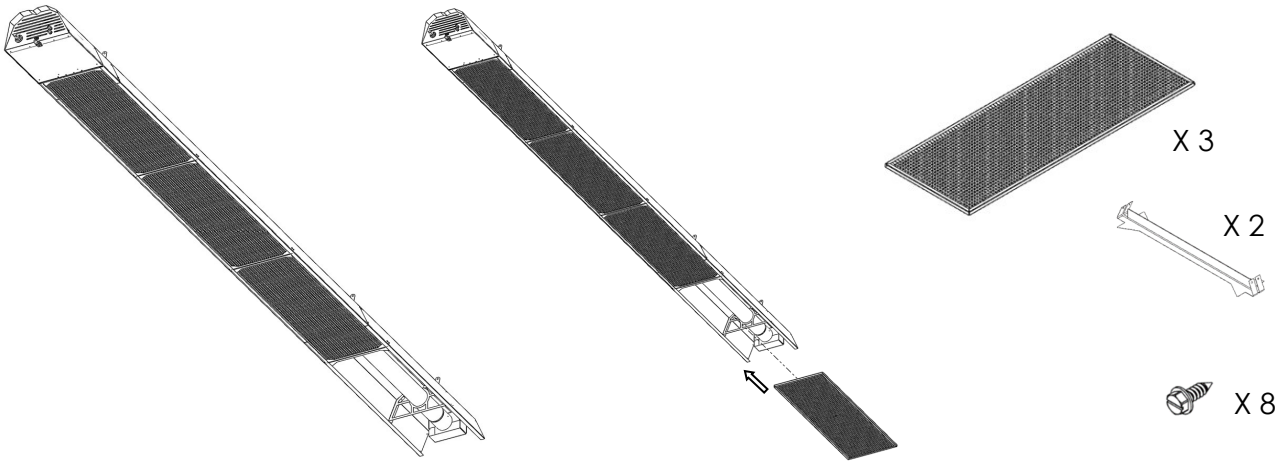

#### Step 8

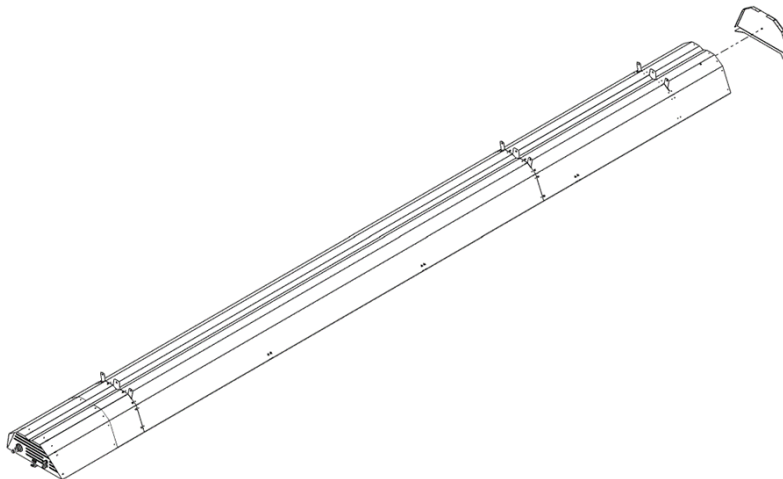

#### Step 9

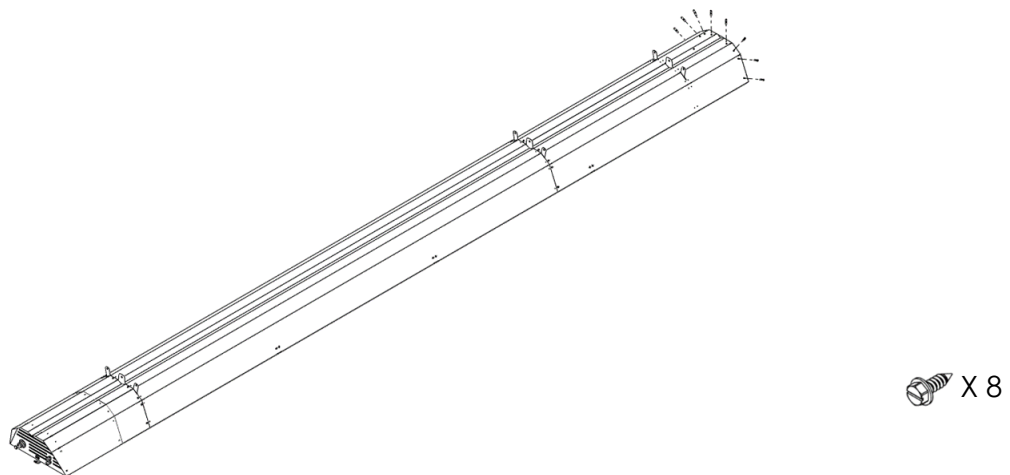



**NOTE: All turbulators are pre-installed. Please keep them in place.**

Improper location of a turbulator can cause malfunction of the heater, property damage, and will void the heater warranty.

The orientation of the turbulator(s) (up - down; sideways) in the tube does not matter.

**TABLE 5: Turbulators: Quantity and location in tube system**

MODEL	Base Length (FT)	TURBULATOR (QUANTITY) x WIDTH x LENGTH	TURBULATOR LOCATION IN BASE LENGTH
STP-TA05-10	10	(1) x 2.25" x 36"	TUBE END
STP-TA08-10	10	(2) x 2.25" x 36"	TUBE END
STP-TA11-15	15	(2) x 2.25" x 36"	2ND TUBE END

**FIGURE 5: Turbulators: Quantity and location in tube system**

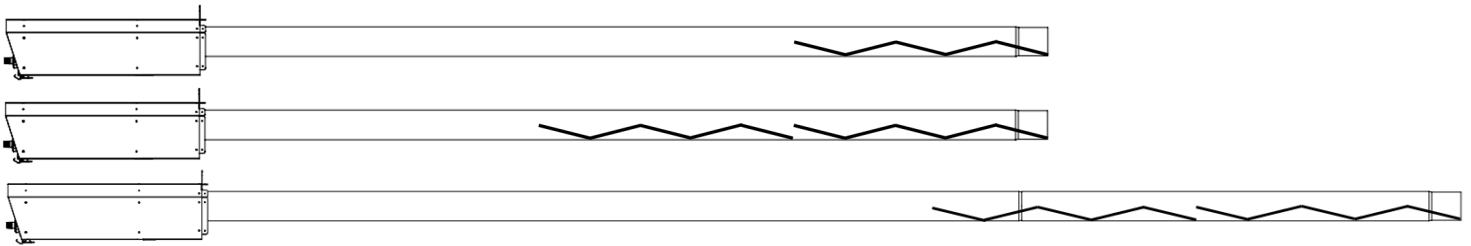

## 7. GAS SUPPLY - FLEXIBLE GAS CONNECTION





### WARNING

### HEATER EXPANSION

**THIS HEATER WILL EXPAND IN LENGTH AS IT HEATS UP.** It is a normal condition that during heat-up and cool-down a tube heater will expand and contract. Some expansion is toward the vent end, and some expansion is at the burner end. Allowances for heater expansion must be made in the gas connection, with flexible gas connector (available for separate order via Part # JL-0771-RC). Improper installation, alteration, or adjustment can result in property damage, injury or death.

**in the USA:** a stainless steel Flexible Gas Connector certified for use on an infrared radiant tube heater per the Standard for *Connectors for Gas Appliances*, ANSI Z21.24/ CSA 6.10

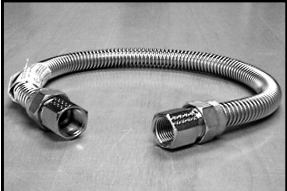
**in CANADA:** a Type 1 Hose Connector (CSA 8.1). Also the flue vent, and combustion air intake (if used) must be installed in such a manner that the normal expansion of the heater will be accommodated.

FLEXIBLE GAS CONNECTOR (ORDER SEPERATELY) - MUST INSTALL	
<p><b>USA - Stainless Steel Flexible Gas Connector</b></p> <p>JL-0771-XX - 1/2"x24"</p> 	<p><b>CANADA - Type 1 Hose Gas Connector</b></p> <p>JL-0771-RC - 1/2"x30"</p> 

The heater must be isolated from the gas supply piping system by closing its individual manual shut off valve (field supplied) during any pressure testing of the gas supply piping system.

**CAUTION:** Compensation for normal gas supply pipe expansion, and radiant tube heater expansion must be provided. All piping must conform to local codes.



Provide a 1/8 in NPT plugged tapping, accessible for test gauge connection, immediately upstream of the gas supply connection to the heater.

**DO NOT** use pressure greater than 1/2 psig to pressure check the heater.



*TEST FOR LEAKS: All gas piping and connections must be tested for leaks after the installation is completed.*

Apply soap suds solution to all connections and joints and if bubbles appear, leaks have been detected and must be corrected. **DO NOT USE A MATCH OR OPEN FLAME OF ANY KIND TO TEST FOR LEAKS. NEVER OPERATE THE HEATER WITH LEAKING CONNECTIONS.**



The supply system should be checked first with heater turned “OFF” followed by another check with heater turned “ON”.



**IMPORTANT:** Minimum supply line pressure at the inlet to the heater regulator must not be lower than 5.0 inches of water column pressure for natural gas, and 11.0” w.c. for propane gas. The supply gas pressure must be checked with all heaters in operation.

Installation of a gas line (trap) “drip leg” is required at the inlet connection tee following the pipe drop to the heater. Failure to provide a “drip leg” could result in condensation and foreign matter passing into the gas valve. Failure to install a “drip leg” in the gas line can cause property damage, injury or death and will void the heater warranty.

INPUT	GAS TYPE	LINE PRESSURE		MANIFOLD PRESSURE (tap at gas valve outlet) INCHES WATER COLUMN
		MINIMUM	MAXIMUM	
Two Stage	Natural Gas	5.0	14.0	3.5 High / 2.2 Low
	Propane Gas	11.0	14.0	10.0 High / 5.0 Low

**NOTE:** Access to the manifold pressure test port is on the top of the valve. A 3/16" Allen Wrench is necessary to remove the plug from the port.

When checking or setting the manifold pressure, a **water manometer or accurate inches water column gauge** must be used. Gauges which measure pounds per square inch are not accurate enough to properly measure and set the pressure.

**FIGURE 9 ORIENTATION OF FLEXIBLE GAS CONNECTOR**



The flexible gas connector **MUST** be installed in the orientation shown below as required by national installation codes and by the certification standard of this heater. This orientation protects the flexible gas connector from damage due to movement during heater expansion.

It is the responsibility of the installer to ensure correct installation of the flexible gas supply.

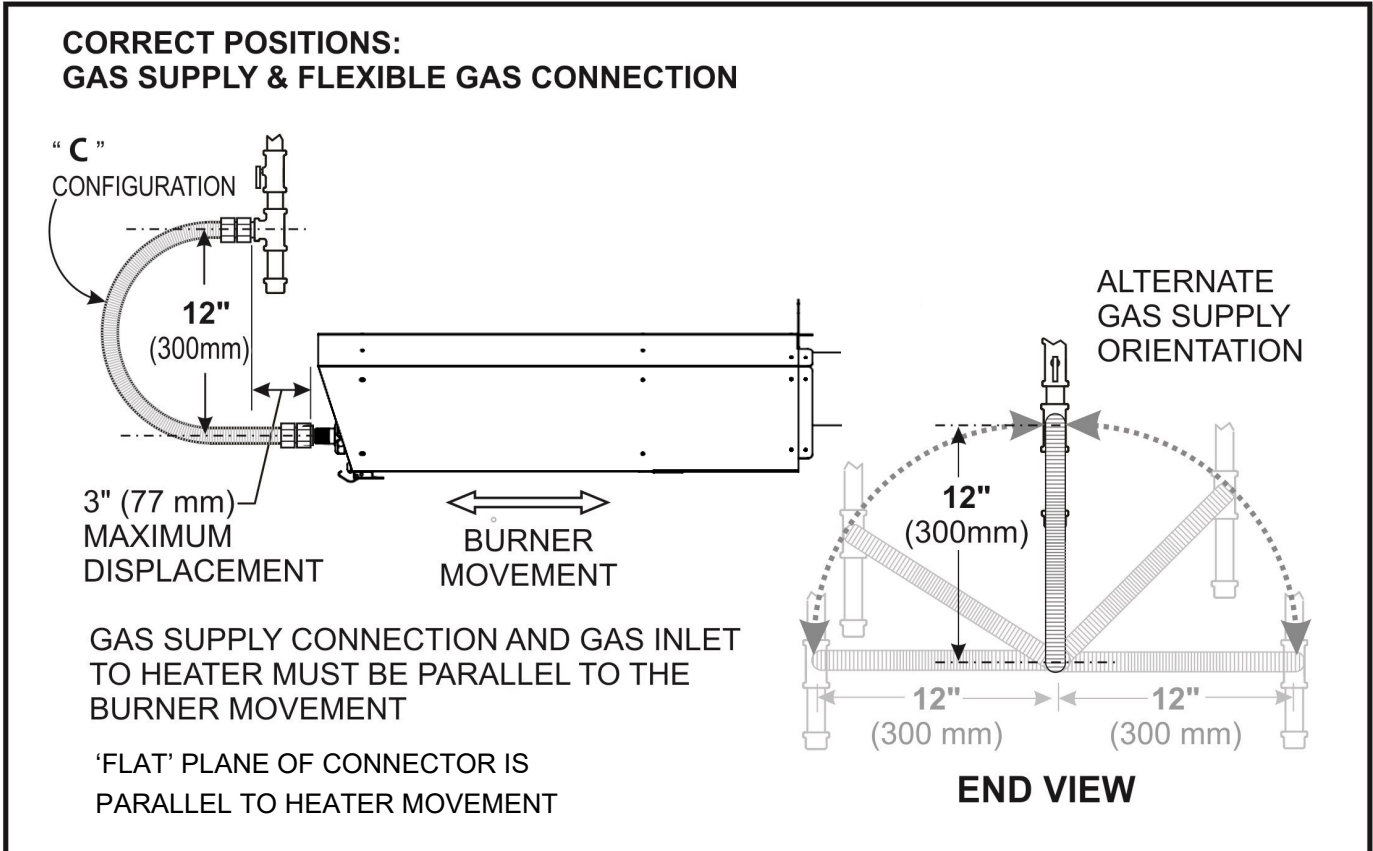

**WARNING: CONNECTOR MUST BE INSTALLED IN A “C” CONFIGURATION. USE ONLY A CONNECTOR OF PROPER LENGTH AND DIAMETER. THE REQUIRED GAS CONNECTOR IS SUPPLIED WITH THE BURNER.**

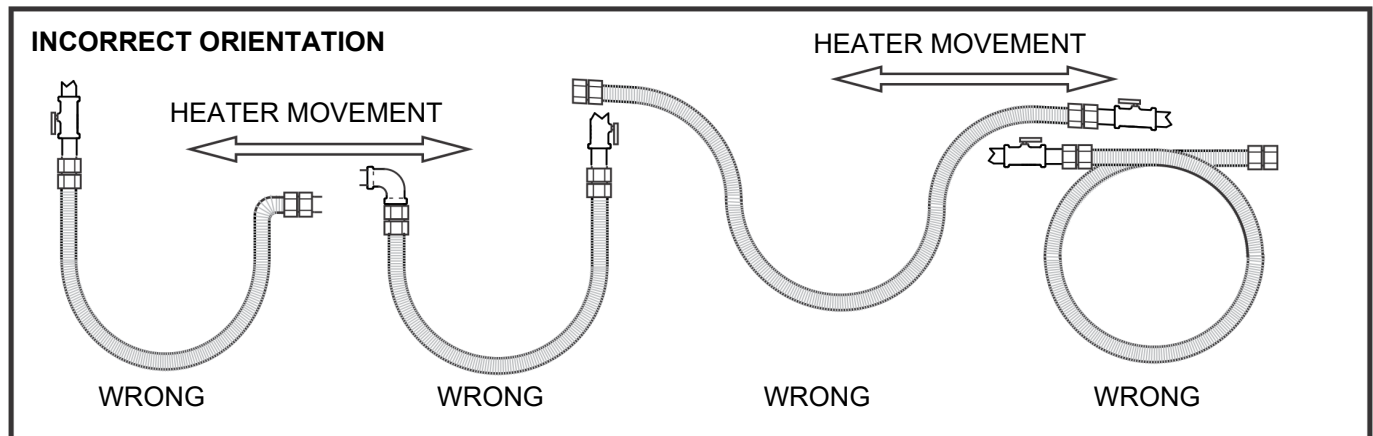

## 8. ELECTRICAL WIRING (WIRING DIAGRAMS NEXT PAGES)



### NOTICE

The heater must be electrically grounded in accordance with the National Electrical Code ANSI/ NFPA 70 in the United States or the Canadian Electrical code CSA C22.1 in Canada.

Appliance and control wiring must be in accordance with all applicable local codes. The total load of all heaters must be considered in determining the required contact rating of the controlling thermostat or switch. Each tube heater requires 120V, 60 HZ electrical power sized for 145VA. Maximum power flow for internal 24V burner components is 21VA.

The Fenwal ignition control includes a 24V/120V relay switch that provides a 45 second pre-purge and 45 second post-purge of the system. To maintain function of the post-purge feature, any **Thermostat / control must be installed in the thermostat circuit from the terminal block (TR - TW)**. A line voltage Thermostat or an "ON/OFF" control switch installed in the 120VAC power supply will disable the post-purge feature.

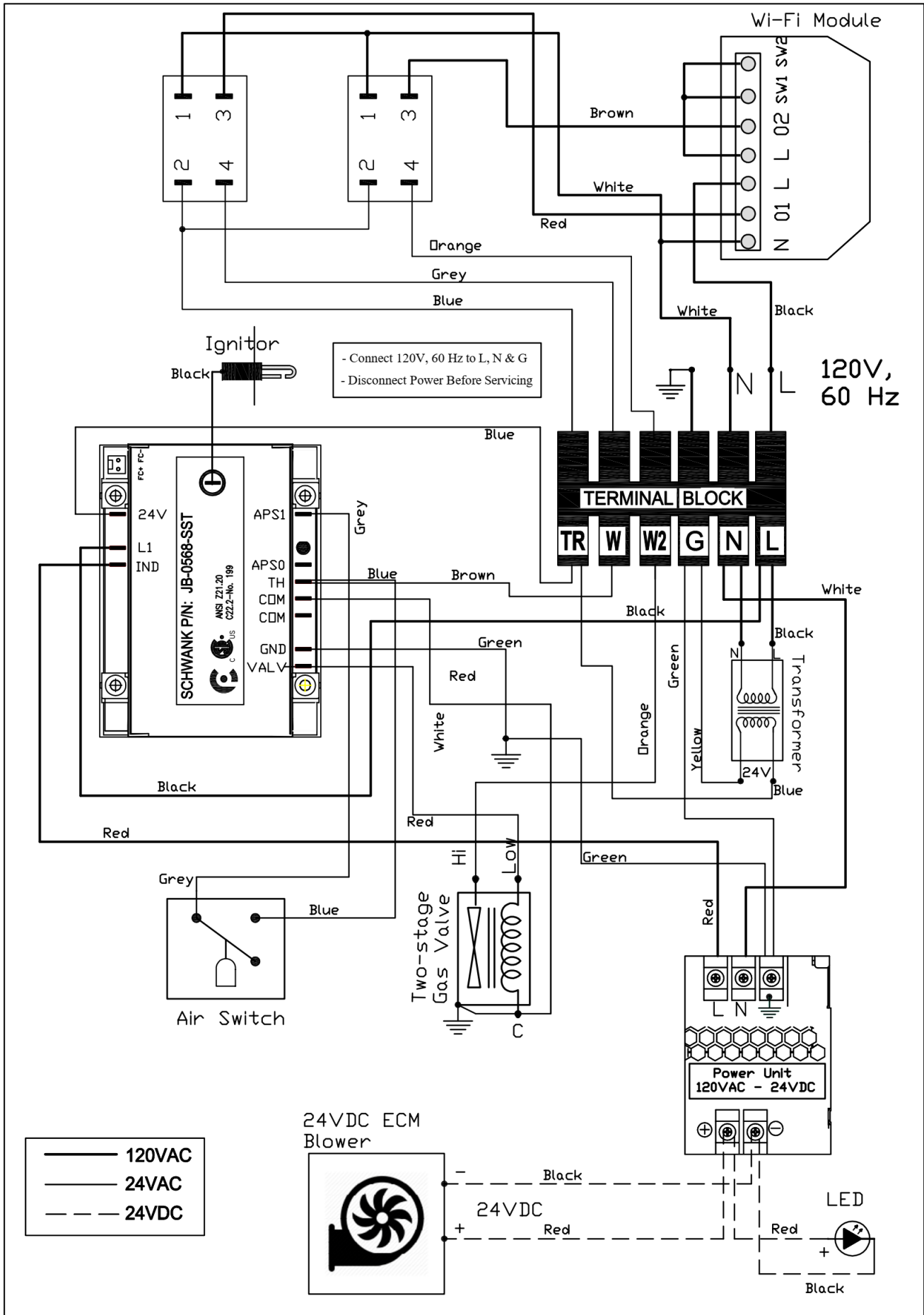

## 9. OPERATION

---

### Power Up / Stand By

Upon applying 24 volts power to 24VAC, the control will reset, perform a self check routine, initiate full time flame sensing, and enter the thermostat scan state.

### Wireless Control

See separate instruction for wireless control.

### Heat Mode

When a call for heat is received from the thermostat supplying 24 volts to TH, the control checks the pressure switch for normally open contacts. The combustion blower is then energized and once the pressure switch contacts close, a 30 second purge delay begins. Following the purge period the gas valve is energized and spark commences for the 15 second trial for ignition.

When flame is detected during the trial for ignition, spark is shutoff immediately and the gas valve combustion blower remains energized. The thermostat, pressure switch, and main burner flame are constantly monitored to assure the system continues to operate properly. When the thermostat is satisfied and the demand for heat ends, the main valve is de-energized immediately, the control senses the loss of flame signal and initiates a 30 second post-purge period before de-energizing the combustion blower.

### Failure to Ignite - Lockout (THREE TRIAL MODEL)

This three-try control will attempt two additional ignition trials with a 30 second inter-purge between trials, before going into 'soft' lockout. The valve relay will be de-energized immediately, and the combustion blower will be turned off following the 30 second post purge period.

If the thermostat continues to call for heat after one hour the control will automatically reset and attempt to ignite the burner again (three trials).

At any time less than the 1 hour auto-reset, recovery from lockout requires a manual reset by either resetting the thermostat or removing 24 volts for a period of 5 seconds.

### Flame Failure - Recycle

If the established flame signal is lost while the burner is operating, the control will go to recycle mode. The HV spark will be energized for a trial ignition period in an attempt to relight the burner. If the burner does not light the control will de-energize the gas valve. Two more attempts will be made to relight the burner. If the burner does not relight the control will go into 'soft' lockout as noted above in "Failure to Light". If flame is re-established, normal operation resumes.

### Combustion Airflow Problems -Lockout

Combustion air flow is continually monitored during an ignition sequence by the air flow switch (PSW). If during the initial call for heat the pressure contacts are in the closed position for 30 seconds without an output to the Combustion Blower, an air flow fault will be declared and the control will remain in this mode with the combustion blower off.

If the air flow switch remains open for more than 30 seconds after the combustion blower output (L1 & IND) is energized, an air flow fault will be declared and the control will stay in this mode with the combustion blower on, waiting for the air flow switch to close.

When proper air flow is detected from the air flow switch input (PSW) the control begins the pre-purge period followed with a 15 second ignition sequence.

If the air flow signal is lost while the burner is firing, the control will immediately de-energize the gas valve and the combustion blower will remain on. If the call for heat remains, the control will wait for proper air flow to return. If proper air flow is not detected after 30 seconds an air flow fault signal will be declared. If proper air flow is detected at any time, a normal sequence will begin with the pre-purge period.



## Flame Fault

If at any time the main valve fails to close completely and maintains a flame, the full time flame sense circuit will detect it and energize the combustion blower. Should the main valve later close completely removing the flame signal, the combustion blower will power off following the optional post purge period.

## MOUNTING AND WIRING

The Series 35-61 is not position sensitive and can be mounted vertically or horizontally. The case may be mounted on any surface with #6 sheet metal screws. All wiring must be done in accordance with local and national electrical code. Refer to wire diagram page 35 when connecting the Series 35-61 to other components in the burner.



## WARNING

The Series 35-61 DSI Control uses voltages of shock hazard potential. Wiring and initial operation must be done by a qualified service technician. The control must be secured in an area that will experience a minimum of vibration and remain below the operating temperature of 160°F. All connections should be made with UL approved 105°C rated 18 gauge, stranded, .054 thick insulated wire. Refer to wire diagram page 35 when connecting the Series 35-61 to other components in the burner.

TERMI-NAL	SPADE	DESIGNATION
TH	1/4"	Thermostat Input
PSW	1/4"	Pressure Switch Input
V1	1/8"	Valve Power (MV)
IND	1/4"	Inducer Blower Output
NC	-	Alarm (Not used)
L1	1/4"	120/240 VAC Input (Hot)
24 VAC	1/4"	24 VAC Supply to Processor
V2	1/8"	Valve (MV)
GND	1/8"	Valve & System Ground
Spark	1/4"	Spark & Local Flame Sense

## CAUTION:

Label all wires prior to disconnection when servicing controls. Wiring errors can cause improper and dangerous operation. A functional checkout of a replacement control is recommended.

## PROPER ELECTRODE LOCATION

Proper location of the electrode assembly is important for optimum system performance. The electrode assembly should be located so that the spark gap is inside the flame envelope about 1 inch (2.5 cm) from the base of the flame at the burner cup.

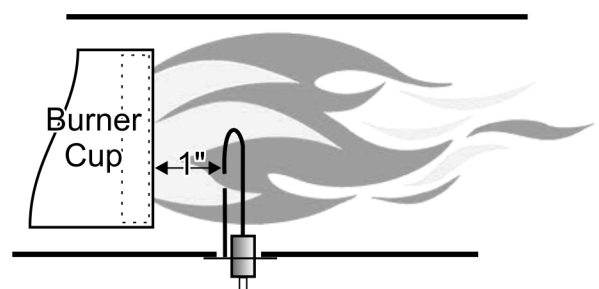

Electrodes should have a gap spacing of 3/16" (0.188" ± 0.031" or 4.76 mm ± 0.81 mm). If this spacing is not correct, the assembly must be adjusted or replaced. DO NOT adjust the curved igniter/sensor prong. Adjust/bend only the ground prong (also see next page).

## SPARK IGNITER SET UP

Use the following diagram to check the Igniter gap. If the gap is incorrect all adjustments should be made to the **GROUND PRONG/PIN ONLY!** **DO NOT BEND THE IGNITER PRONG!!!!**

**USE THE BLACK BARS BELOW AS A GUIDE FOR ADJUSTMENT. USE THE BARS THAT COINCIDE WITH THE FORMAT & SIZE OF THIS PUBLICATION .**

If this manual is in

**8.5" x 11"** "booklet" format  
(pages folded in half)

then use these bars

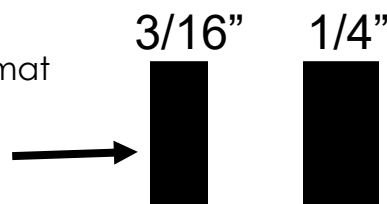

OR

If this manual is printed  
8.5" x 11" "**full page**" format

use these bars

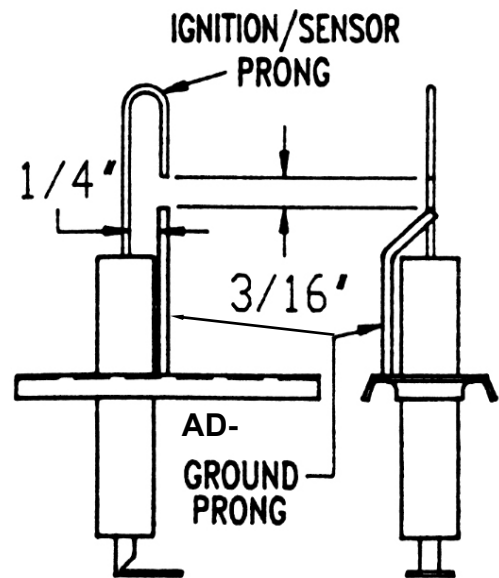
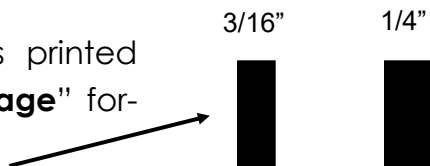

## SERVICE CHECKS

Flame current passes through the flame from the sensor to ground. The minimum flame current necessary to keep the system from lock-out is 0.7 microamps. To measure flame current, connect an analog DC microammeter to the FC- FC+ terminals per figure at right.

Meter should read 0.7  $\mu$ A or higher. If the meter reads below "0" on scale, meter leads are reversed. Disconnect power and reconnect meter leads for proper polarity.

Multipurpose Meter

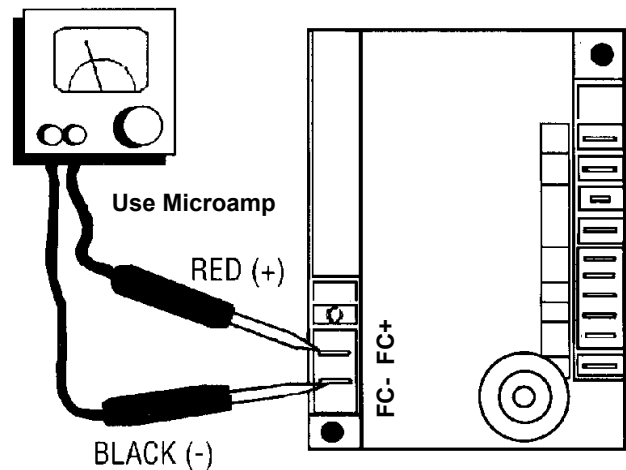

## HIGH ALTITUDE INSTALLATIONS - Refer to TABLE 6

When installed above the altitude stipulated below for USA and Canada, the input must be de-rated by 4% for each 1000 ft above the altitude listed. Refer to the tables below for orifice size and restrictions that apply to high altitude installation (including total system length restrictions). Check with your local utility regarding the gas supply and the de-rating of this appliance. Maintain gas supply pressure indicated in Section 6.

**USA:** The factory installed orifice for this appliance is approved for altitudes zero to 2000 feet above sea level.

**Canada:** The factory installed orifice for this appliance is approved for altitudes zero to 4500 feet above sea level.

### Altitude Restrictions this Model:

1. Do not install at altitudes greater than 8,500 ft
2. Restrict the length of any model to the shortest tube length at altitudes greater than 4,500 ft

When this appliance is installed above the altitude stipulated in the Table below, the input must be de-rated by 4% for each 1000 ft of altitude. **If your local utility supplies gas with a de-rated heat content, no orifice change is required in the heater** . Check with your local utility regarding de-rating, and the following specifically for country of installation.

### ORIFICE CONVERSION

Tube Heater Burners are factory produced and supplied to operate on natural gas.

A field conversion kit is available from the manufacturer and must be used to convert from natural gas to propane gas. Each kit contains the required parts and specific instructions to make the gas conversion.

FIGURE 10: REMOVING THE BURNER CUP AND THE ORIFICE

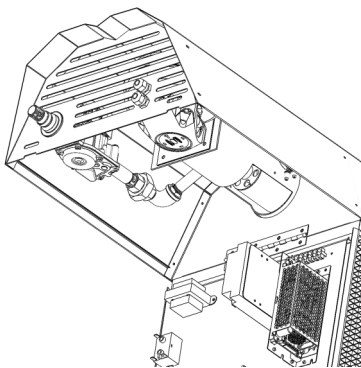

1. Open the combustion chamber bottom cover.
2. Unscrew the 2 screws holding the burner cup cover and remove the cover
3. Break the burner cup loose and unscrew it.
4. Move the burner cup forward a little and tilt the stem down.
5. Pull out the Burner cup.
6. Once the burner cup is removed the orifice can be reached at the orifice holder in the combustion chamber.
7. Replace the orifice.
8. Reverse step 2 to 5 to install new orifice.
9. Close the combustion chamber bottom cover.

**TABLE 6 HIGH ALTITUDE INSTALLATION - ORIFICE TABLE**

**SCHWANK RECOMMENDED ORIFICES - ALTITUDE CONVERSION**

Canada: When installed above 4500 feet, refer to the Local Provincial Authority having juris-

MODEL IN-PUT RATE (MBH)	FOR USE AT ALTITUDES ABOVE (FEET)							
	Gas Orifice Drill Size / Part #							
	Supplied	USA						
	0	2000	3000	4000	5000	6000	7000	8000
50 NG	#30 JS-0730-DM	#31 JS-0731-DM	#31 JS-0731-DM	#31 JS-0731-DM	#32 JS-0732-DM	#32 JS-0732-DM	#33 JS-0733-DM	#33 JS-0733-DM
50 LP	#47 JS-0747-DM	#47 JS-0747-DM	#48 JS-0748-DM	#48 JS-0748-DM	#48 JS-0748-DM	#49 JS-0749-DM	#49 JS-0749-DM	#50 JS-0750-DM
80 NG	#20 JS-0720-DM	#21 JS-0721-DM	#21 JS-0721-DM	#21 JS-0721-DM	#22 JS-0722-DM	#22 JS-0722-DM	#24 JS-0724-DM	#25 JS-0725-DM
80 LP	#41 JS-0741-DM	#42 JS-0742-DM	#42 JS-07428-DM	#42 JS-0742-DM	#43 JS-0743-DM	#44 JS-0744-DM	#45 JS-0745-DM	#46 JS-0746-DM
115 NG	#5 JS-0705-DM	#6 JS-0706-DM	#6 JS-0706-DM	#6 JS-0706-DM	#8 JS-0708-DM	#10 JS-0710-DM	#11 JS-0711-DM	#12 JS-0712-DM
115 LP	#33 JS-0733-DM	#34 JS-0734-DM	#34 JS-0734-DM	#34 JS-0734-DM	#35 JS-0735-DM	#36 JS-0735-DM	#37 JS-0737-DM	#37 JS-0737-DM

## 10. TROUBLESHOOTING GUIDE - FENWAL DSI

(also see Heater Troubleshooting next page)

SYMPTOM	RECOMMENDED ACTION(S)
<b>1. Dead</b>	<ul style="list-style-type: none"> <li>A. Miswired - check electrical supply (120Vac ± 5%)</li> <li>B. Transformer bad (24Vac ± 10%)</li> <li>C. Fuse/Circuit breaker bad</li> <li>D. Bad control (check LED for steady on)</li> <li>E. 24VDC Power Unit is bad</li> </ul>
<b>2. Thermostat on - no blower output</b>	<ul style="list-style-type: none"> <li>A. Miswired</li> <li>B. Bad thermostat no voltage @ terminal W</li> <li>C. Bad control (check LED for steady on)</li> <li>D. 24VDC Power Unit is bad</li> </ul>
<b>3. Pressure switch input okay, but no Trial-for- ignition after purge delay</b>	<ul style="list-style-type: none"> <li>A. Miswired (check PSW terminal voltage: 24Vac ± 10%)</li> <li>B. Flame sense problem (existing flame: check LED - 2 flashes)</li> <li>C. Bad control (check line voltage between L1 &amp; IND)</li> </ul>
<b>4. Valve on, no spark</b>	<ul style="list-style-type: none"> <li>A. Shorted electrode</li> <li>B. Open HV cable</li> <li>C. Bad control</li> </ul>
<b>5. Spark on, no valve</b>	<ul style="list-style-type: none"> <li>A. Valve coil open</li> <li>B. Open valve wire</li> <li>C. Bad control (check 24Vac voltage between V1 &amp; V2)</li> </ul>
<b>6. Flame ok during TFI, no flame sense (after TFI)</b>	<ul style="list-style-type: none"> <li>A. Bad electrode</li> <li>B. Bad HV igniter wire</li> <li>C. Poor ground at burner</li> <li>D. Poor flame (check flame current)</li> </ul>

## 10. TROUBLESHOOTING GUIDE - HEATER OPERATION



### WARNING

Improper adjustment, alteration, service or maintenance can cause property damage, injury or death. This heater must be installed and serviced only by a trained gas service technician

#### SEQUENCE OF EVENTS (also see *DSI Troubleshooting previous page*)

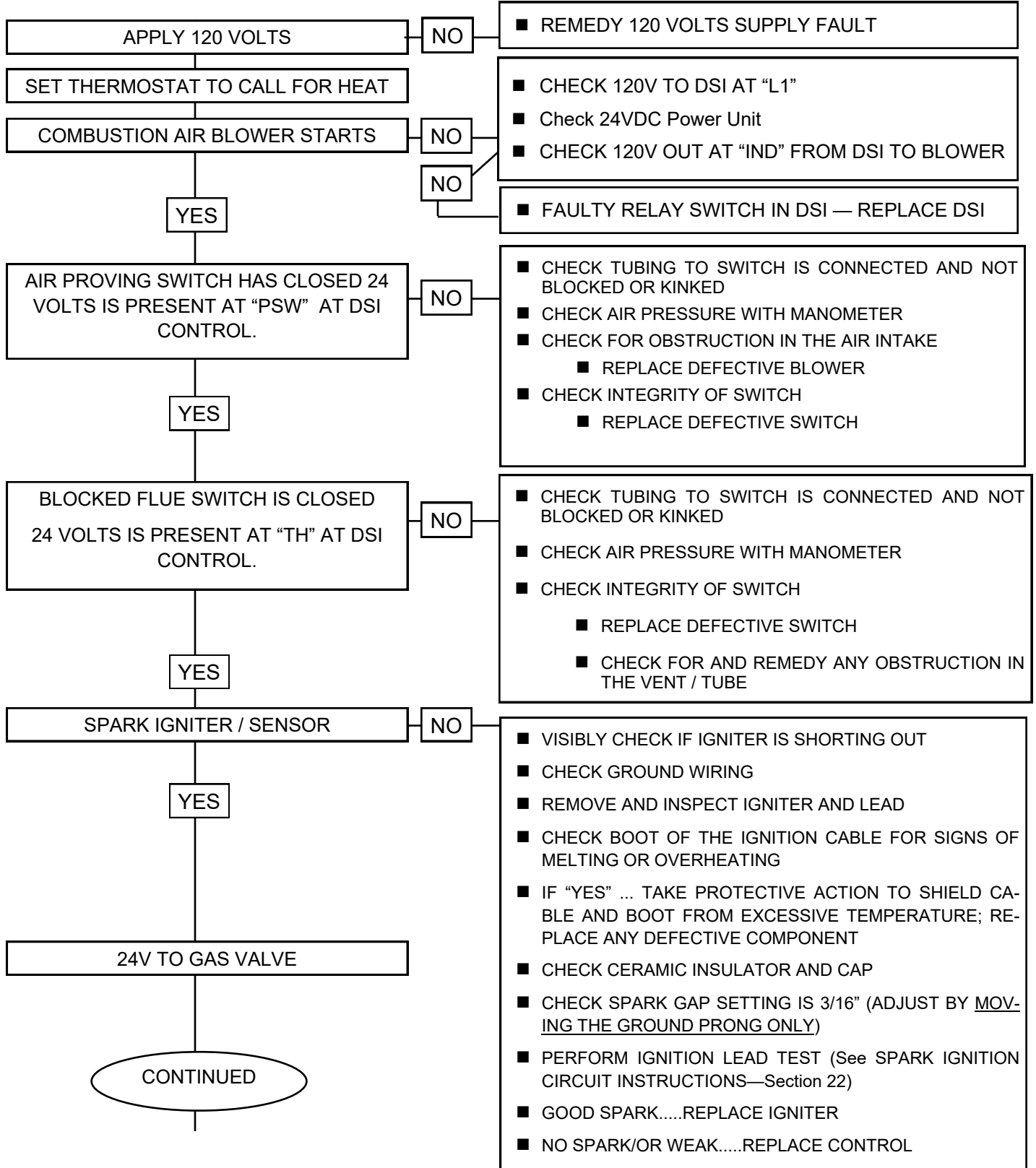

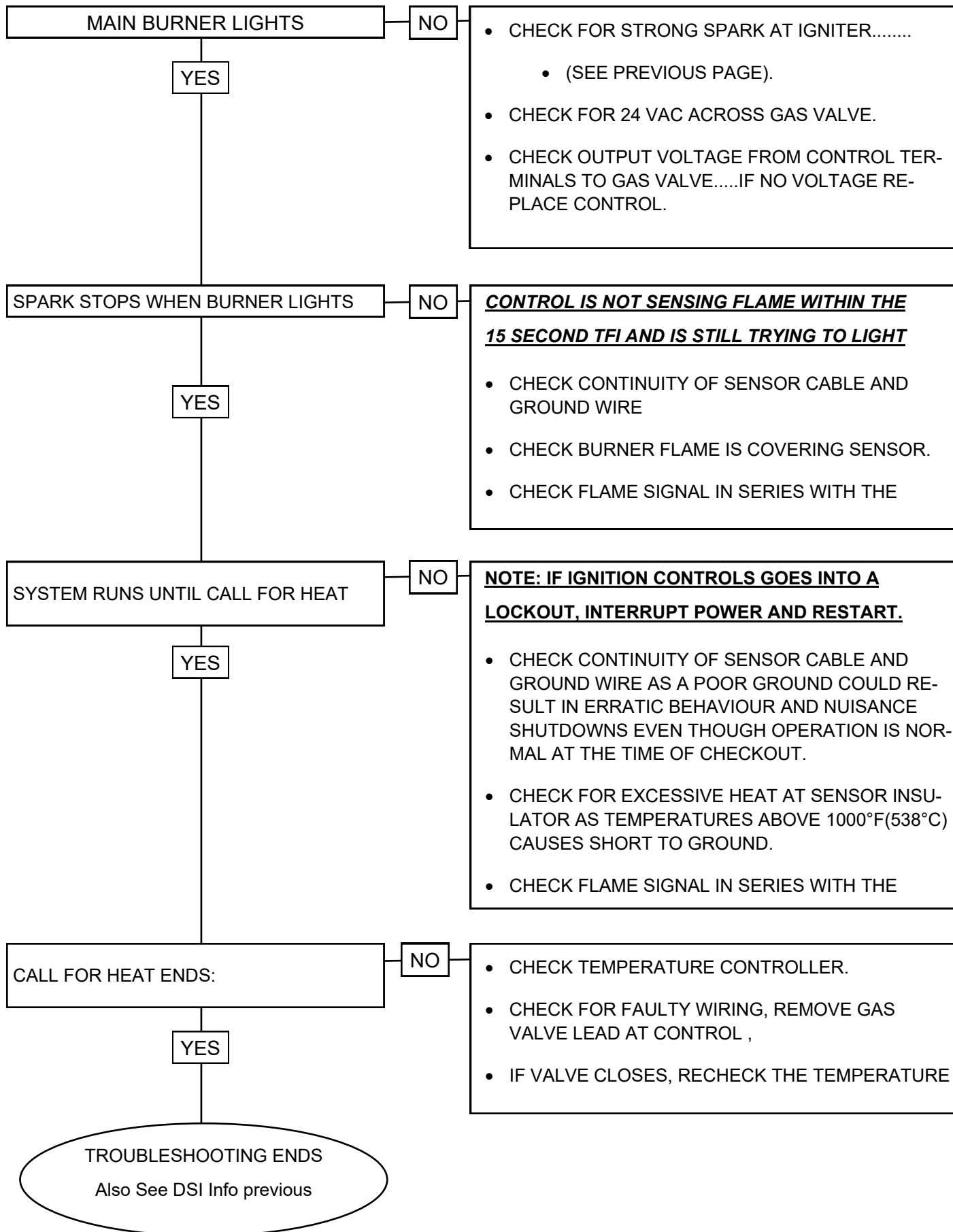

## 11. START-UP / COMMISSIONING SHEET



THIS EQUIPMENT HAS BEEN FACTORY FIRED AND TESTED PRIOR TO SHIPMENT. HOWEVER, THIS APPLIANCE IS NOT "PLUG & PLAY". IT REQUIRES COMMISSIONING AND FIELD ADJUSTMENT / SPECIFICATIONS CONFIRMATION TO ENSURE SAFE AND EFFICIENT OPERATION.

### COMMISSIONING REPORT AS PER I&O MANUAL AND LOCAL CODES

CONTRACTOR NAME: .....DATE.....

ADDRESS:.....  
.....

CITY:.....

PHONE:.....

CELL: .....

JOB SITE.....CITY.....

HEATER MODEL NUMBER:.....  
*Located on burner rating plate*

HEATER SERIAL NUMBER: .....

TO ENSURE THAT SITE CONDITIONS ARE COMPATIBLE WITH THE HEATER'S PERFORMANCE AND TO ALLEVIATE NUISANCE CALL-BACKS, THE FOLLOWING START-UP NEEDS TO BE COMPLETED BY THE QUALIFIED GAS INSTALLER.

A TECHNICIAN CALLING FOR TECHNICAL SUPPORT MUST PROVIDE THE INFORMATION FROM THE COMPLETED COMMISSIONING REPORT ON THE NEXT PAGE

FAX COMPLETED REPORT TO TECHNICAL SERVICES:

FAX 1-866-361-0523, VOICE 1-877-446-3727



#### WARNING

#### START UP 'SMOKE'

During start up, material coatings used in the production process of tubes and reflectors will "burn off" and create smoke during the first hour of operation. This is temporary and normal. Please ensure that there is sufficient ventilation to adequately clear the smoke from the space. Notify site and safety personnel to ensure that alarm systems are not unduly activated.



**QUALIFIED INSTALLER TO COMPLETE THIS**

TYPE OF GAS: NG  LP

DOES BUILDING HAVE A NEGATIVE CONDITION: YES  NO

IF THIS IS A HIGH ALTITUDE AREA WHAT IS THE ALTITUDE ABOVE SEA LEVEL  Ft

DOES APPLICATION REQUIRE FRESH AIR TO BURNER YES  NO

IS HEATER EXPOSED TO CHEMICAL OR CORROSIVE ATMOSPHERE: YES  NO

ARE ACTUAL MINIMUM CLEARANCES AS PER TABLE 3 YES  NO

CAN HEATER BE AFFECTED BY OVERHEAD CRANES / VIBRATION YES  NO

ARE GAS SUPPLY LINES ADEQUATELY SIZED FOR SYSTEM YES  NO

GAS LINES AND BRANCHES HAVE BEEN PURGED OF AIR: YES  NO

THIS HEATER FIRED WITHOUT ANY MALFUNCTION: YES  NO

INLET GAS SUPPLY PRESSURE WITH HEATER OPERATING :  WC"

GAS VALVE OUTLET (Manifold) PRESSURE WITH HEATER OPERATING:  WC"

WHAT IS THE LINE VOLTAGE READING AT THE HEATER  VOLTS

WHAT IS THE VOLTAGE READING AT THE IGNITION MODULE  VOLTS

WHAT IS THE FLAME SIGNAL STRENGTH IN uA FROM SENSOR:  uA (microamps)

IS HEATER CONTROLLED BY A THERMOSTAT YES  NO

IS THE THERMOSTAT STRATEGICALLY LOCATED YES  NO

WHAT IS TOTAL LENGTH OF INSTALLED THERMOSTAT WIRE  FEET

WHAT IS THE GAUGE OF THE THERMOSTAT WIRE  GAUGE

WHAT IS THE HEATER TUBE LENGTH (10ft per Tube section)  FEET

WHAT IS THE TOTAL LENGTH OF THE VENT (add 10ft for each bend)  FEET

WHAT LENGTH IS COMBUSTION AIR INTAKE (add 10ft for each bend)  FEET

IF REQUIRED....WHAT IS THE LENGTH OF THE TURBULATOR(S)  FEET

IF INSTALLED....IS TURBULATOR AT FLUE END OF SYSTEM YES  NO

"MAXIMUM STACKING HEIGHT" SIGN(S) - POSTED AT THERMOSTAT(S)

**THIS HEATER MUST BE ELECTRICALLY GOUNDED**



## LIMITED WARRANTY CERTIFICATE

### FOR GAS-FIRED INFRA-RED LOW INTENSITY TUBE HEATERS: STP SERIES

The Manufacturer warrants that this product is free from defects in material or workmanship under normal use and service subject to the terms of this document.

### THREE YEAR WARRANTY

Subject to the conditions and limitations stated herein, during the term of this limited warranty, we will supply any component part (at our option a new or repaired component part) of the heater as defined below, excluding any labor, which the Manufacturer's examination determines to be defective in workmanship or material for a period of three years (3 years) from the date of installation, unless otherwise specified below. This warranty applies to the heater's original owner, and subsequent transferees and only if the unit is installed and operated in accordance with the printed instructions accompanying the unit and in compliance with all applicable installation codes and good trade practices. Warranty is only applicable to Schwank components, other parts are limited to their own Manufacturers warranty period of one year (1 year).

### TEN YEAR WARRANTY

The Manufacturer warrants the burner cup sub-assembly, and the radiating tubes (excluding couplings) for a period of ten years (10 years).

### WHAT IS NOT COVERED

The Manufacturer shall not be responsible for any expenses, including service, labor, diagnosis, analysis, material or transportation charges incurred during removal or reinstallation of this product, or any of its components or parts. All labor or service charges shall be paid by the owner. This warranty does not cover heating products improperly installed, misused, exposed to or damaged by negligence, accident, corrosive or contaminating atmosphere, water, excessive thermal shock, impact, abrasion, normal wear due to use, alteration or operation contrary to the owner's manual or if the serial number has been altered, defaced or removed. This warranty shall not apply if the input to the heating product exceeds by more than 2% of the rated input on the rating plate. The Manufacturer shall not be liable for any default or delay in performance by its warranty caused by any contingency beyond its control, including war, government restrictions, or restraints, strikes, fire, flood, acts of God, or short or reduced supply of raw materials or products.

### WARRANTY PROCEDURE

To establish the installation date for any purpose under this Limited Warranty, you must retain the original records that can establish the installation date of your unit. If you do not provide such documents, the start date of the term of this Limited Warranty will be based upon the date of unit manufacture, plus thirty (30) days. Failure to maintain the equipment through regular annual service maintenance by a qualified service technician shall void the warranty.

### LIMITATIONS AND EXCLUSIONS

This document contains all warranties made by the Manufacturer and may not be varied, altered or extended by any person. There are no promises, or agreements extending from the Manufacture other than the statements contained herein. THIS WARRANTY IS IN LIEU OF ALL WARRANTIES EXPRESSED OR IMPLIED, TO THE EXTENT AUTHORIZED BY THE LAWS OF THE JURISDICTION, INCLUDING SPECIFICALLY THE WARRANTIES OR MERCHANTABILITY OF FITNESS FOR A PARTICULAR PURPOSE.

It is understood and agreed that the Manufacturer's obligation hereunder is limited to repairing or replacing parts determined to be defective as stated above. In no event shall the Manufacturer be responsible for any alleged personal injuries or other special, incidental or consequential damages. As to property damages, contract, tort or other claim the Manufacturer's responsibility shall not exceed the purchase price paid for the product.

All replacement parts will be warranted for the unused portion of the warranty coverage period remaining on the applicable unit.

Some Authorities do not allow certain warranty exclusions or limitations on duration of warranty or the exclusions or limitations of incidental or consequential damages. In such cases, the above limitations or exclusions may not apply to you and are not intended to do so where prohibited by law. This warranty gives you specific legal rights. You may also have other rights which vary by jurisdiction.

#### **SCHWANK GROUP**

**2 SCHWANK WAY, WAYNESBORO, GEORGIA. 30830**

**5285 BRADCO BLVD. MISSISSAUGA, ON, L4W 2A6**

**Ph: 1-877-686-3779**

**Fax: 1-866-361-0523**