

Round 20



Round 20 Design features



1. Decorative Media

Fire Pit Kits come with black glass charcoal.

**Decorative media is not to be placed directly on top of the burner or anywhere they can interfere with the operation of the burner or the stability of flame.*

2. Black Hi-Temp Coated Stainless Steel Tray

All Fire Pit Kits feature an Inlay Black Tray to house the compatible burner, included decorative media and glass fire screen.

Clean Burning Flame

Unlike traditional wood fire pits, our fire pit kits produce no smoke, no soot, and no ash for an enjoyable experience without the mess.

3. Triple Fuel Advantage

Choose between plumbed natural gas, readily available propane, or our eco-friendly bioethanol fuel system. We make it easy for you to achieve exactly what you want, for exactly where you want it.

Burner Colors

Bioethanol models are available with a Stainless Steel or Black Burner.

Versatile and Incredibly Durable

EcoSmart Fire Pits are versatile, incredibly durable, and are constructed of weather resistant materials. These appliances are designed to look great for years, and will perform admirably through all four seasons.

4. Glass Fire Screen

Crafted from toughened, tempered glass for higher strength and shatter resistance, the windscreen is equipped for outdoor performance.

Global Compliance

This model complies with existing standards in the USA, Europe, UK and Australia. O-TL listed to UL1370, EN 16647 BSI Certified and ACCC Safety Mandate compliant.

Included Accessories



Black Glass Charcoal

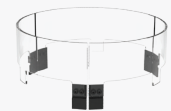

Glass Fire Screen



Jerry Can with Safety Spout & e-NRG bottle adaptor*



Lighting Rod & Lighter*



AB8 Efficiency Ring*

*Ethanol models only.

Disclaimer: All product specifications and data are subject to change without notice and believed to be correct at the time of publication. MAD Design Group (MDG), its affiliates, agents, and employees, and all persons acting on its or their behalf (collectively, "MAD Design Group"), disclaim any and all liability for any errors, inaccuracies or incompleteness contained herein or in any other disclosure relating to any product. MDG disclaims any and all liability arising out of the use or application of any product described herein or of any information provided herein to the maximum extent permitted by law. The product specifications do not expand or otherwise modify MDG's terms and conditions of purchase, including but not limited to the warranty expressed therein, which apply to these products. No license, express or implied, by estoppel or otherwise, to any intellectual property rights is granted by this document or by any conduct of MDG. Customers using or selling MDG products not expressly indicated for use in such applications do so entirely at their own risk and agree to fully indemnify MDG for any damages arising or resulting from such use or sale. Please contact authorised personnel from MDG to obtain written terms and conditions regarding products designed for such applications. Images are indicative only.

Round 20 Specifications

The Round 20 Fire Pit Kit's curved compact design and single flame, create an inviting fire pit for smaller, more intimate spaces.

Burner Ventilation and Efficiency*

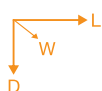

Dimensions L x W x D mm/in	Compatible Burner	Fuel Capacity	Heats on Average (Indoors)	Thermal Output Net (MAX per burner)	Approx. Burn Time	Minimum Room Size
630 x 630 x 339 24.8 x 24.8 x 13.3	AB8 (Ethanol)	8 L [2.1 Gals]	Over 60 m ² [645 ft ²]	21.56 MJ/h 20,433 BTU/h, 5.99 kW	7 - 9 hours	116 m ³ [4,096 ft ³]
	Liquid Propane	NA	Outdoor Use Only	65,000 BTU/h	8 - 20 hours	Outdoor Use Only
	Natural Gas				Unlimited	

Application ¹	Indoor & Outdoor
Color & SKU	Black ESF.B.FPK.R.20.E ESF.B.FPK.R.20.G
Bioethanol Burner Colors	Stainless Steel Black
Materials	Black Hi-Temp Coated Stainless Steel Tray, Toughened Glass Fire Screen, Grade 304 Stainless Steel Burner, with optional Black Ceramic Coating
Approx. Weight	22kg [48.5lbs] Weight includes burner and accessories.
Fuel Type	e-NRG Bioethanol, Liquid Propane or Natural Gas

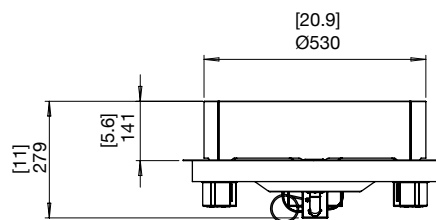

FRONT AND SIDE VIEW (Gas)

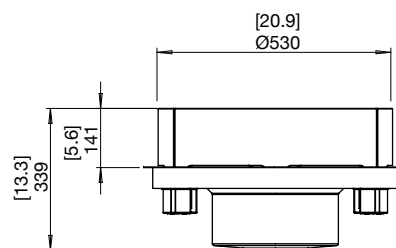

FRONT AND SIDE VIEW (Bioethanol)

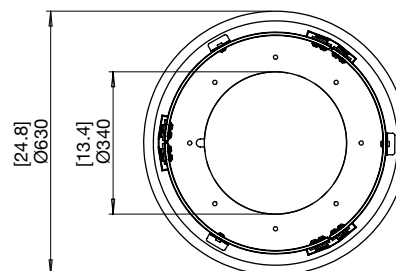

TOP VIEW

*These values are indicative only.

¹ LP/NG is suited for Outdoor use only. Bioethanol is suited for both Indoor/Outdoor use, however, additional parts are REQUIRED for indoor use. Please advise your Sales Representative at the time of purchase so that the product can be configured accordingly.

This model comes with fixing brackets for permanently locating into a fixed position.

This model complies with existing standards in the USA, Europe, UK and Australia. O-TL listed to UL 1370, EN 16647 BSI Certified and ACCC Safety Mandate compliant for bioethanol burners. LP/NG burners are UL/ULC listed to ANSI Z21.97-2017 and CSA 2.41-2017

FOR MORE INFORMATION PLEASE REFERENCE THE CLEARANCE & INSTALLATION MANUAL

Disclaimer. All product specifications and data are subject to change without notice and believed to be correct at the time of publication. MAD Design Group (MDG), its affiliates, agents, and employees, and all persons acting on its or their behalf (collectively, "MAD Design Group"), disclaim any and all liability for any errors, inaccuracies or incompleteness contained herein or in any other disclosure relating to any product. MDG disclaims any and all liability arising out of the use or application of any product described herein or of any information provided herein to the maximum extent permitted by law. The product specifications do not expand or otherwise modify MDG's terms and conditions of purchase, including but not limited to the warranty expressed therein, which apply to these products. No license, express or implied, by estoppel or otherwise, to any intellectual property rights is granted by this document or by any conduct of MDG. Customers using or selling MDG products not expressly indicated for use in such applications do so entirely at their own risk and agree to fully indemnify MDG for any damages arising or resulting from such use or sale. Please contact authorized personnel from MDG to obtain written terms and conditions regarding products designed for such applications. Images are indicative only.

Round 20 Cut-out dimensions

Bioethanol

Outdoor & Indoor Application

Physical model dimensions should be verified against cut out dimensions BEFORE installation begins to confirm tolerances align.

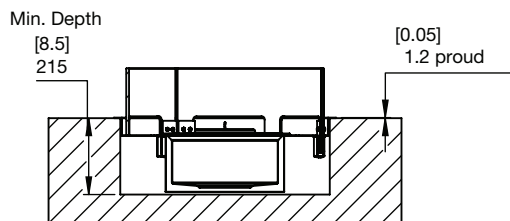
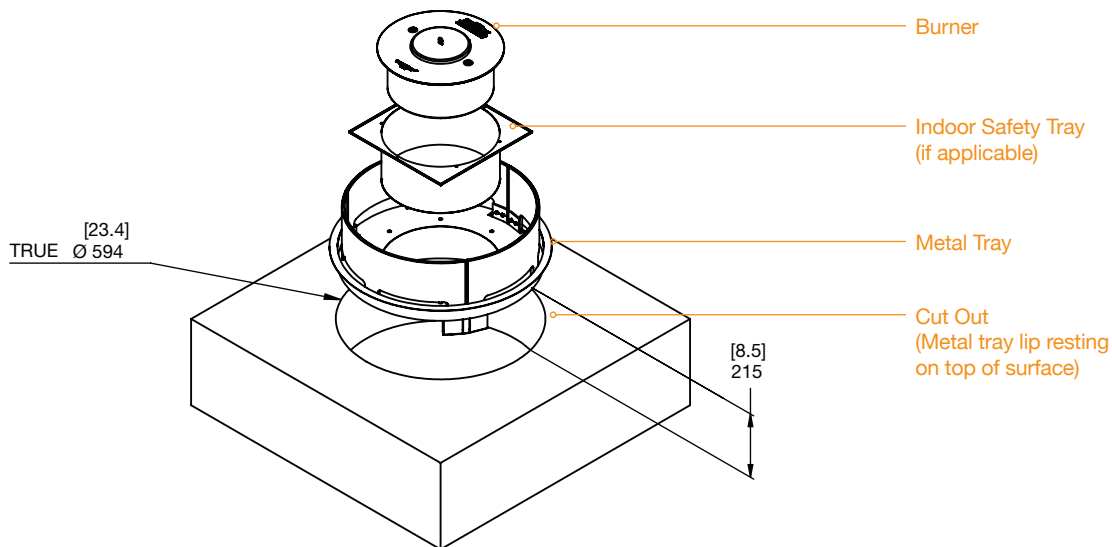

FOR MORE INFORMATION PLEASE REFERENCE THE CLEARANCE & INSTALLATION MANUAL

Disclaimer: All product specifications and data are subject to change without notice and believed to be correct at the time of publication. MAD Design Group (MDG), its affiliates, agents, and employees, and all persons acting on its or their behalf (collectively, "MAD Design Group"), disclaim any and all liability for any errors, inaccuracies or incompleteness contained herein or in any other disclosure relating to any product. MDG disclaims any and all liability arising out of the use or application of any product described herein or of any information provided herein to the maximum extent permitted by law. The product specifications do not expand or otherwise modify MDG's terms and conditions of purchase, including but not limited to the warranty expressed therein, which apply to these products. No license, express or implied, by estoppel or otherwise, to any intellectual property rights is granted by this document or by any conduct of MDG. Customers using or selling MDG products not expressly indicated for use in such applications do so entirely at their own risk and agree to fully indemnify MDG for any damages arising or resulting from such use or sale. Please contact authorised personnel from MDG to obtain written terms and conditions regarding products designed for such applications. Images are indicative only.

Round 20 Cut-out dimensions

Hard Piped Natural Gas

Outdoor Application only

Physical model dimensions should be verified against cut out dimensions BEFORE installation begins to confirm tolerances align.

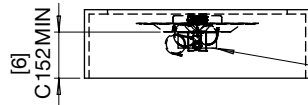
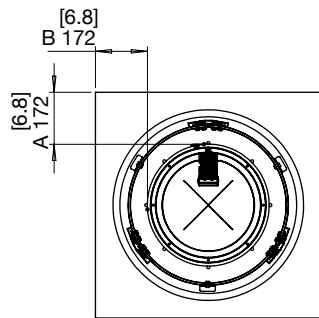
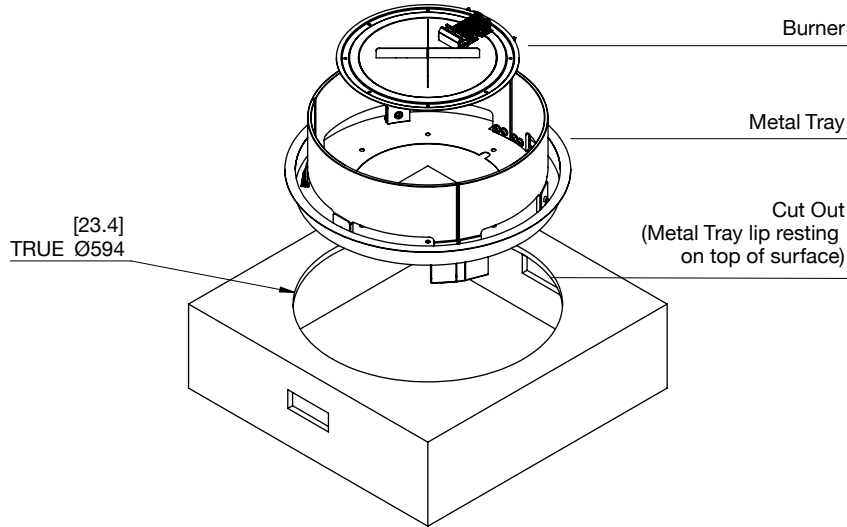

A 1/8IN ROD MUST BE ABLE TO PASS THROUGH ALL VENTS. NO SCREEN OR MESH SHOULD BE USED.

MINIMUM REQUIREMENT

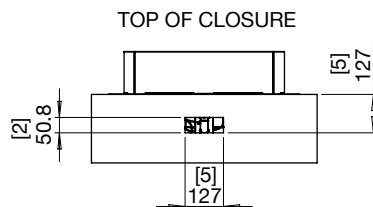

**HARD-PIPED NATURAL GAS ENCLOSURE
2 EQUAL SIZE VENTS REQUIRED.
VENTS SHOULD BE WITHIN 127MM [5IN]
OF THE TOP OF CLOSURE.**

FOR MORE INFORMATION PLEASE REFERENCE THE CLEARANCE & INSTALLATION MANUAL

Disclaimer: All product specifications and data are subject to change without notice and believed to be correct at the time of publication. MAD Design Group (MDG), its affiliates, agents, and employees, and all persons acting on its or their behalf (collectively, "MAD Design Group"), disclaim any and all liability for any errors, inaccuracies or incompleteness contained herein or in any other disclosure relating to any product. MDG disclaims any and all liability arising out of the use or application of any product described herein to the maximum extent permitted by law. The product specifications do not expand or otherwise modify MDG's terms and conditions of purchase, including but not limited to the warranty expressed therein, which apply to these products. No license, express or implied, by estoppel or otherwise, to any intellectual property rights is granted by this document or by any conduct of MDG. Customers using or selling MDG products not expressly indicated for use in such applications do so entirely at their own risk and agree to fully indemnify MDG for any damages arising or resulting from such use or sale. Please contact authorized personnel from MDG to obtain written terms and conditions regarding products designed for such applications. Images are indicative only.

Round 20 Cut-out dimensions

Hard Piped Propane

Outdoor Application only

Physical model dimensions should be verified against cut out dimensions BEFORE installation begins to confirm tolerances align.

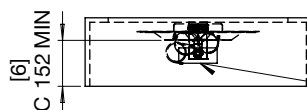
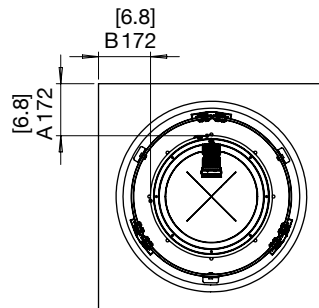
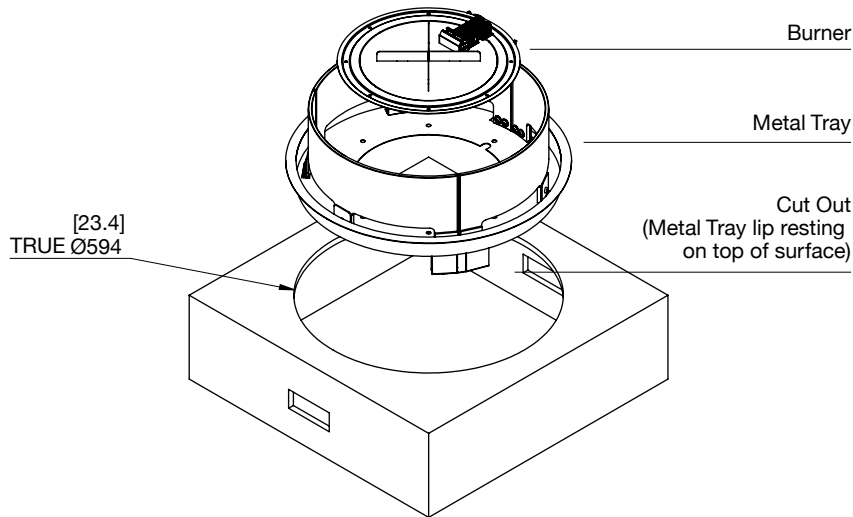

A 1/8IN ROD MUST BE ABLE TO PASS THROUGH ALL VENTS. NO SCREEN OR MESH SHOULD BE USED.

MINIMUM REQUIREMENT

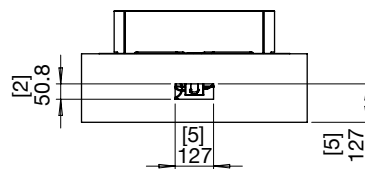

BOTTOM OF CLOSURE

HARD-PIPED PROPANE ENCLOSURE
2 EQUAL SIZE VENTS REQUIRED.
VENTS SHOULD BE WITHIN **127MM [5IN]**
OF THE BOTTOM OF CLOSURE.

FOR MORE INFORMATION PLEASE REFERENCE THE CLEARANCE & INSTALLATION MANUAL

Disclaimer: All product specifications and data are subject to change without notice and believed to be correct at the time of publication. MAD Design Group (MDG), its affiliates, agents, and employees, and all persons acting on its or their behalf (collectively, "MAD Design Group"), disclaim any and all liability for any errors, inaccuracies or incompleteness contained herein or in any other disclosure relating to any product. MDG disclaims any and all liability arising out of the use or application of any product described herein or of any information provided herein to the maximum extent permitted by law. The product specifications do not expand or otherwise modify MDG's terms and conditions of purchase, including but not limited to the warranty expressed therein, which apply to these products. No license, express or implied, by estoppel or otherwise, to any intellectual property rights is granted by this document or by any conduct of MDG. Customers using or selling MDG products not expressly indicated for use in such applications do so entirely at their own risk and agree to fully indemnify MDG for any damages arising or resulting from such use or sale. Please contact authorized personnel from MDG to obtain written terms and conditions regarding products designed for such applications. Images are indicative only.

Round 20 Cut-out dimensions

Self Contained Propane

Outdoor Application only

Physical model dimensions should be verified against cut out dimensions BEFORE installation begins to confirm tolerances align.

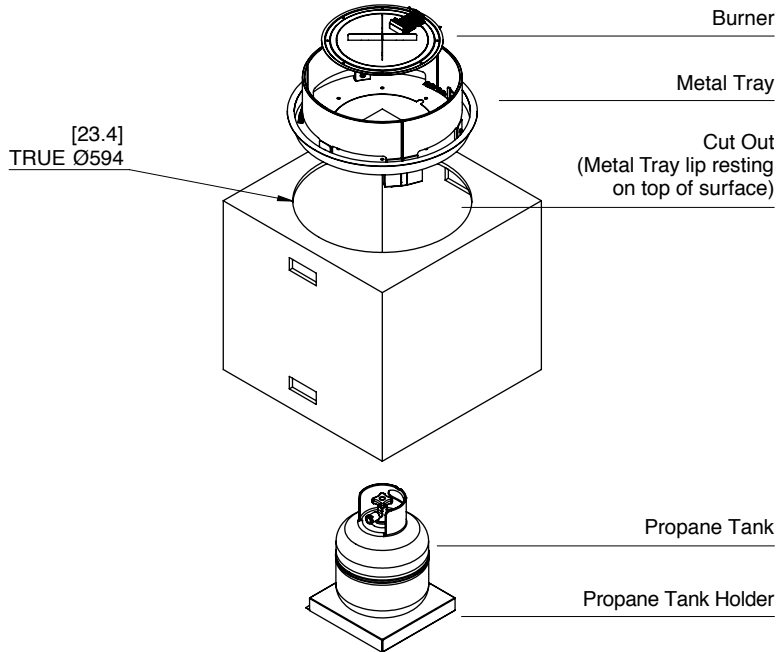

NOTE: Retention means must be provided to limit the movement of the LP gas cylinder.

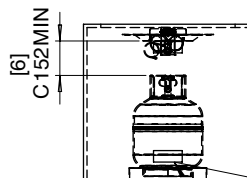
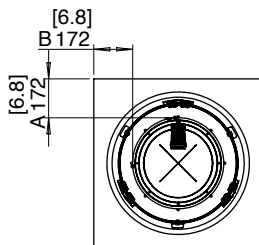

A 1/8IN ROD MUST BE ABLE TO PASS THROUGH ALL VENTS. NO SCREEN OR MESH SHOULD BE USED.

MINIMUM REQUIREMENT

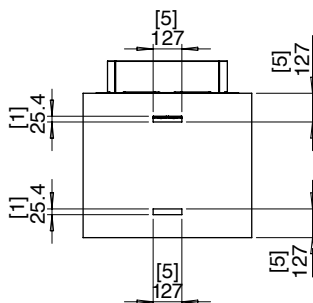

10LBS PROPANE BOTTLE ENCLOSURE
4 EQUAL SIZE VENTS REQUIRED

MINIMUM REQUIREMENT

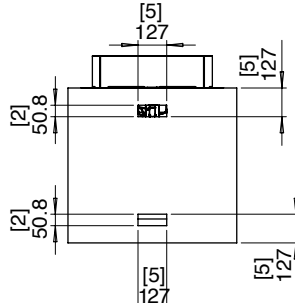

20LBS PROPANE BOTTLE ENCLOSURE
4 EQUAL SIZE VENTS REQUIRED

TOP VENTS SHOULD BE WITHIN **127MM [5IN]** OF THE **TOP** OF CLOSURE.
BOTTOM VENTS SHOULD BE WITHIN **127MM [5IN]** OF THE **BOTTOM** OF CLOSURE.

FOR MORE INFORMATION PLEASE REFERENCE THE CLEARANCE & INSTALLATION MANUAL

Disclaimer: All product specifications and data are subject to change without notice and believed to be correct at the time of publication. MAD Design Group (MDG), its affiliates, agents, and employees, and all persons acting on its or their behalf (collectively, "MAD Design Group"), disclaim any and all liability for any errors, inaccuracies or incompleteness contained herein or in any other disclosure relating to any product. MDG disclaims any and all liability arising out of the use or application of any product described herein or of any information provided herein to the maximum extent permitted by law. The product specifications do not expand or otherwise modify MDG's terms and conditions of purchase, including but not limited to the warranty expressed therein, which apply to these products. No license, express or implied, by estoppel or otherwise, to any intellectual property rights is granted by this document or by any conduct of MDG. Customers using or selling MDG products not expressly indicated for use in such applications do so entirely at their own risk and agree to fully indemnify MDG for any damages arising or resulting from such use or sale. Please contact authorized personnel from MDG to obtain written terms and conditions regarding products designed for such applications. Images are indicative only.