



aFire.Water.Vapor

User manual

ENGLISH (Draft November 6th 2018)



ENGLISH

Installation, Use, and Maintenance Notice

AFIRE devices standard compliance:

Original AWO Line: Commercial references: AWO 20-50, AWO 40-100

Premium AWP Line: Commercial references: AWP 20-50, AWP 40-100, AWP 60-150

XXL Line: Commercial references: AWX 40-100, AWX 60-150

AWA Corner Line, AWB Line, AWD Line, AW-VIP

Complies with:

- European directives: 2004/108/EC EN 55014-1 :2006+A1 :2009+A2 :2011
EN 55014-2 :1997+A1 :2001+A2 :2008
EN 6100-3-2 :2006+A1 :2009+A2 :2009
EN 6100-3-3 :2013
- Part 15 of FCC regulations

1- **PRECAUTIONS:**

Before first use, we recommend reading this manual carefully.

The device must be installed in compliance with the instructions in paragraphs 3, 4, and 5.

Users are prohibited from interfering with the safety systems.

Installation and use of the devices are subject to the rules and procedures for use in the country where the devices are installed.

Do not use the device if it is damaged after falling or any other reason. Contact AFIRE aftersales service.

Do not let children or disabled persons use the device without supervision.

Do not use outdoors.

Do not use the device in places exposed to flammable products such as gasoline or other solvents.

Cut off electric power before any handling of the device, in particular before cleaning, transporting, or repairing it.

For storage, be sure to keep the device in a dry location with no risk of damage.

Do not modify the device. Its use must comply with this manual.





ATTENTION! SAFETY WARNING

Use in a regularly ventilated room.

Ventilation vents in the room must not be obstructed and/or ventilation systems in the home must not be hindered.

If the power cable to your device is damaged, it must be replaced by AFIRE to eliminate possible problems.

Never use accessories not supplied by AFIRE.

Keep the remote control out of reach of children. It contains batteries. If batteries are swallowed, contact a doctor immediately.

Only use new batteries. Using recharge or old batteries or batteries that are not adapted or batteries inserted backward may cause an explosion and cause injury.

FCC precaution: Modifications not expressly approved by the party responsible for compliance will result in canceling the user's right to use the device.

2- DEVICE TECHNICAL CHARACTERISTICS

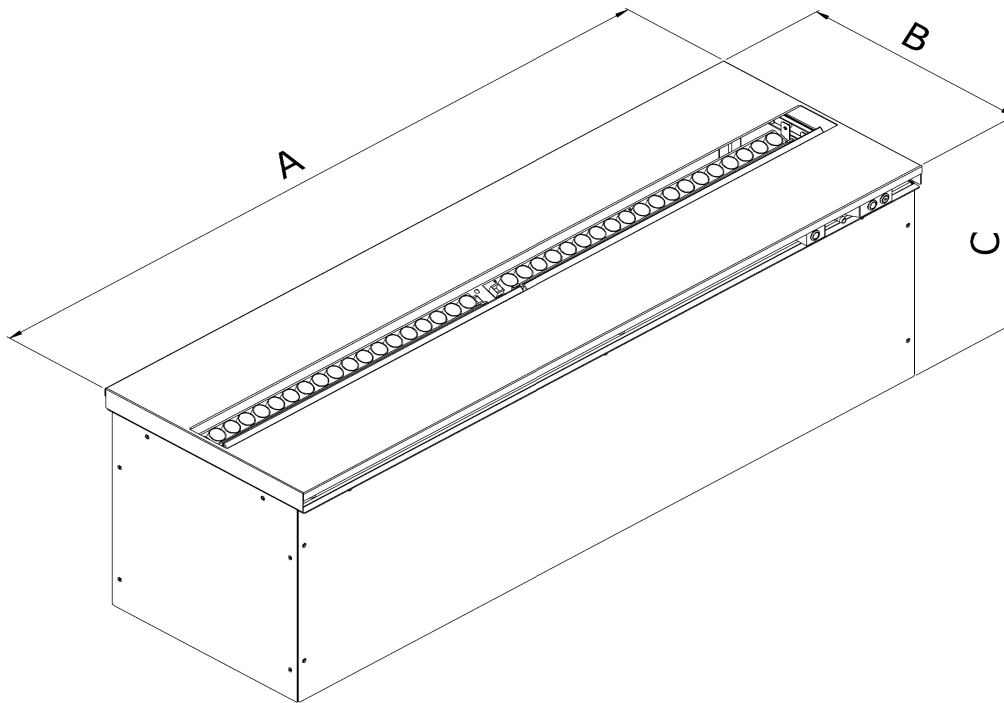

Models	A Length	B Width	C Height
AWP20-50	508mm(20in)	326mm(12.83in)	300mm(11.81in)
VP40-100 / AWX40-100	1016mm(40in)	326mm(12.83in)	300mm(11.81in)
VP60-150 / AWX60-150	1524mm(60in)	326mm(12.83in)	300mm(11.81in)
AWO20-50	508mm(20in)	326mm(12.83in)	235mm(9.25in)
AWO40-100	1016mm(40in)	326mm(12.83in)	235mm(9.25in)

Models	Reservoir capacity		Autonomy	Electric power	Weight	
	Liter	Gallon	Hour	Watt	KG	LBS.
AWP20-50	2	0,528	20	60	13	28,66
AWP40-100	4	1,056	20	120	26	57,32
AWP60-150	6,5	1,584	20	180	40	88,18
AWX40-100	4	1,056	20	120	26	57,32
AWX60-150	6,5	1,584	20	180	40	88,18
AWO20-50	2	0,528	20	38	11	24,25
AWO40-100	4	1,056	20	76	22	48,50

Device delivered with a radio remote control.

Device equipped with exterior connection (dry contact) to allow for remote operation with a distant switch or by a smart-home installation. Never start or use a device without supervision.

Device equipped with a Wi-Fi application for smartphones.

3. PRECAUTIONS FOR INSTALLING THE DEVICE IN ITS ENVIRONMENT:

Do not place any object on the device while operating. Leave access to the control components free.

Do not use in presence of strong air currents.

4. ELECTRIC CONNECTION TO YOUR DEVICE

Your device is sent with INPUT electric power of 100-240 volts (50/60 Hz) and OUTPUT of 24 volts.

Before embedding your device, you must connect the electric power to a 100-240 volt/50/60 Hz – 12-amp circuit.

If you want to use an external connection for a remote control switch or smart-home installation, you must use the dry contact port meant for this purpose.



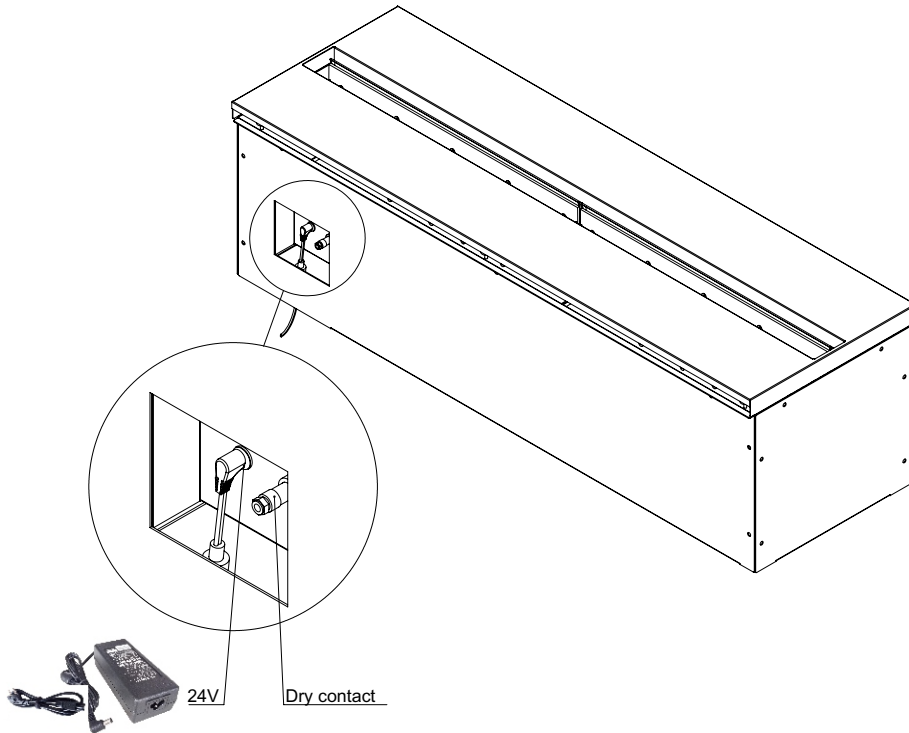

5. Installation diagrams:

AFIRE devices are meant to be embedded without needing any ventilation in the housing for the device.

In the housing, you must install a normal 110/240 volt (12 amp) electric current in order to power the device through a 24-volt transformer.

You must also install water supply if you want to connect your device directly.

See the daagram below for the embedding dimensions.

You must leave 5 cm minimum around the device to facilitate installation.

Embedding dimensions:

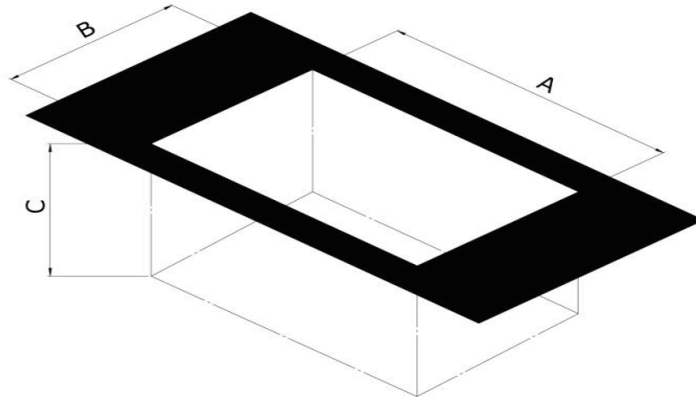

References	A Length	B Width	C Depth
AWP 20-50	514mm(20.24in)	314mm(12.36in)	328mm(12.91in)
AWP 40-100	1022mm(40.24in)	314mm(12.36in)	328mm(12.91in)
AWP 60-150	1530mm(60.24in)	314mm(12.36in)	328mm(12.91in)
AWO 20-50	514mm(20.24in)	314mm(12.36in)	263mm(10.35in)
AWO 40-100	1022mm(40.24in)	314mm(12.36in)	263mm(10.35in)

6. Electric diagram

This diagram represents the 3 possibilities of connection depending on the model used: AWP 20-50, AWP 40-100, AWP 60-150, AWO 20-50, AWO 40-100, AWA, AWB, AWD, AW-VIP

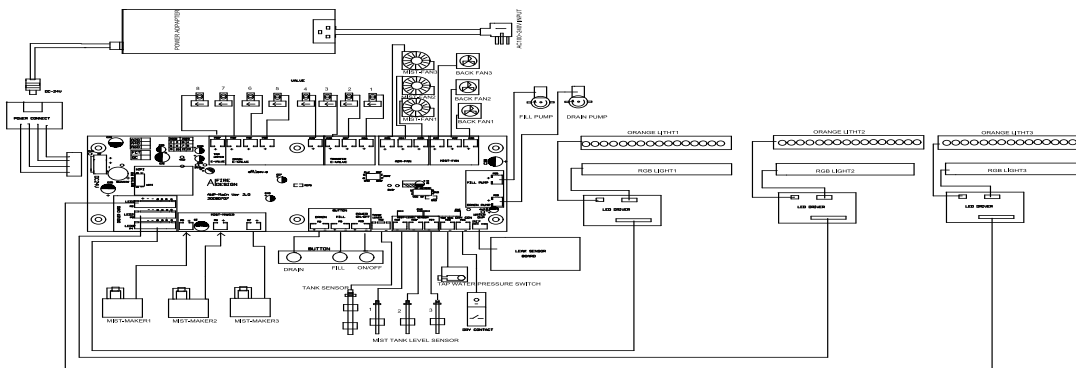

7. INSTRUCTIONS FOR USE:

A- Description of the control strip

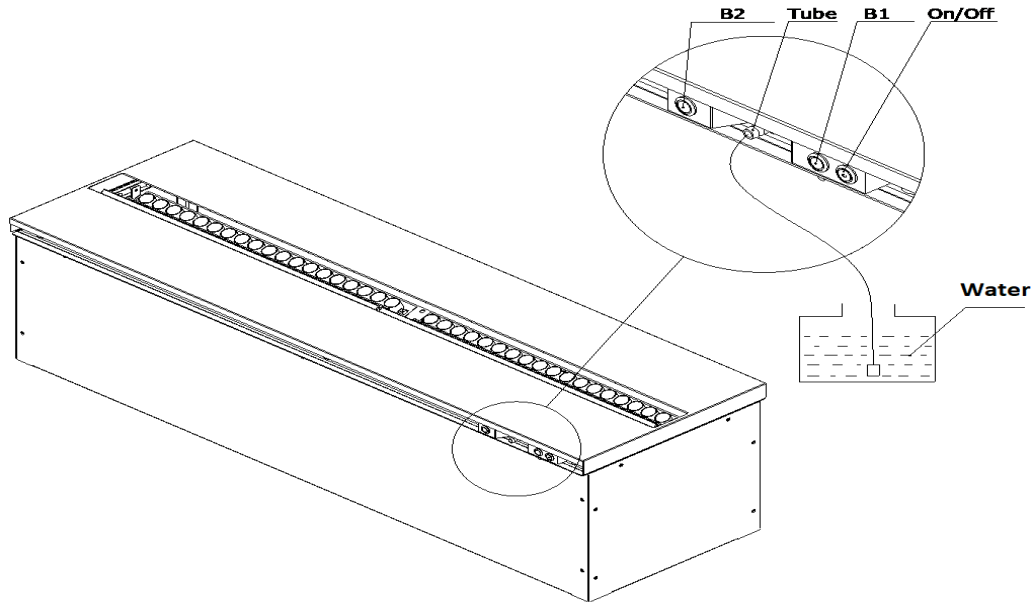

The **ON/OFF button** turns the device on and off. **Button B1** is used to fill the reservoir with water. **Button B2** is used to empty the device. **Hold the button for 5 seconds to start the pumps.** Press once to stop the pumps. The stainless-steel “Tube” connection connects to the plastic hose provided to fill and empty the device.

ATTENTION: The water used must be perfectly clean with no dust or residue that may clog the hydraulic system. This point is very important for the operation of your device.

B- Using your device for the first time

Depending on your type of device (PREMIUM AWP, XXL AW, Angle AWA, AW-VIP), it may be connected directly to your home’s water network (see diagram below, ¼”). In this case, if you press the ON/OFF button and the isolation tap on the hydraulic circuit is open, the device will fill automatically. **In all cases, if you do not use your device, shut off the inbound water supply to avoid leaking.**

If the device is not connected to the water network, you can fill the reservoir using button B1 (fill). To do so, first, connect the provided hose to the stainless connector (tube) and submerge the part of the hose with its filter in a container of water. Then, press the ON/OFF button. The row of orange LEDs will blink immediately (empty reservoir). Then, press B1 once and the filling pump will start and stop automatically when the reservoir is full. The orange LEDs will remain on and vapor will start to come out of your device. Note: for the first filling, you will need: 2 liters for AWP 20-50 and AWO2 0-50, 4 liters for AWP 40-100, AWO 40-100, and AWX 40-100, 6.5 liters for AWP 60-150 and AWX 60-150. Then, you can control your device using the remote control or the smartphone app.

If your device is an ORIGINAL AWO, filling is done manually. You will need to remove the top plate to access the reservoir cap. When filling, be sure not to let the water overflow, and preferably use a funnel.

C- Caution:

Tap water may be used in our devices, **however, be sure the water is not considered to be “hard” and that it contains no impurities (may clog valves).** If your water is hard, you must use filtered or softened water in order not to wear out the Transducer Fog Maker too quickly. **Important Note:** Minerals are needed in the water in order for the Transducer Fog Maker to function. Therefore water purified via **reverse osmosis** must have minerals added back into the water in order for fog to be produced.

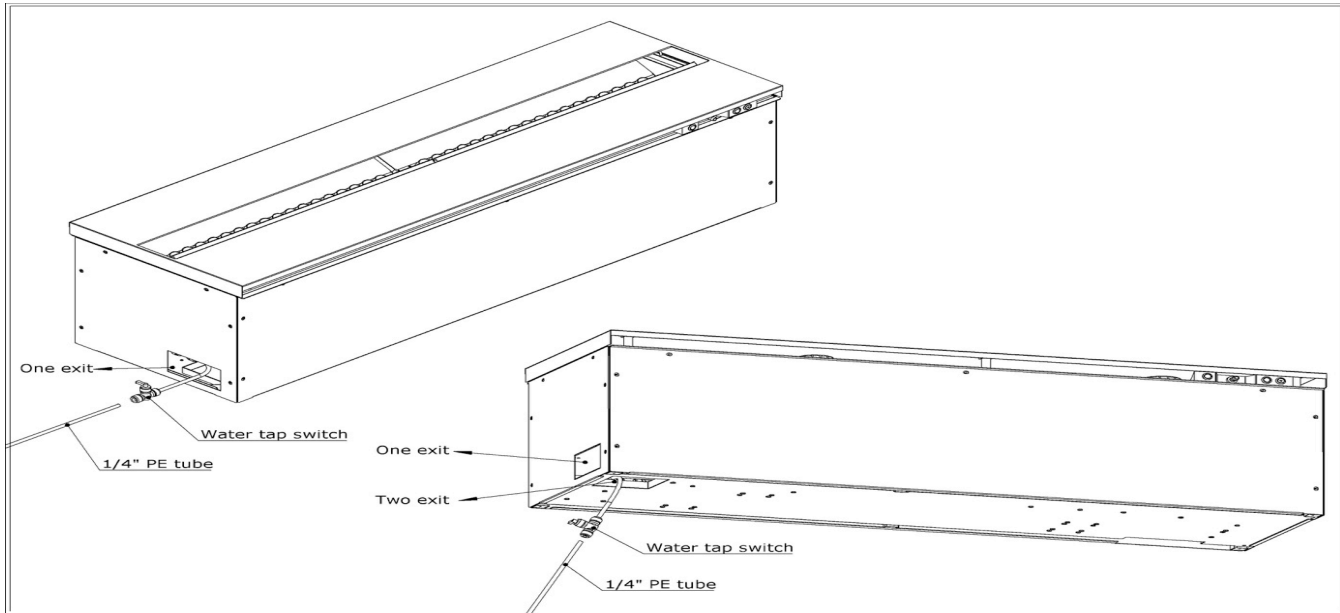

Direct connection to the water network $\frac{1}{4}$ "

D- Using the device

AFIRE devices have several control possibilities.

1- Manual (On/Off button)

2- Via radio remote control

The remote control is paired with your device in the factory. However, if you want to change your remote control, you must install the new one onto your device (device in OFF position). Just press and hold the ON/OFF button for 5 seconds. **The ON/OFF button will start to blink. Then, simply press any button on the remote control.** You will hear a confirmation beep, and the remote control will be paired to the module.

Buttons on your remote control:

On/Off: turns the device on or off. Attention: the ON/OFF button on the device must be switched on (see paragraph xxxx).

Orange On/Off Orange: The row of orange LEDs can be switched on or off.

RGB On/Off: Starts or stops the RGB lights.

Flame height: Increases or decreases the height of the flame. With each change of height, the device will beep. At the maximum and minimum settings, the device will no longer beep. There are 8 settings possible.

Flame speed: Changes the speed of the flames. At the maximum and minimum settings, the device will no longer beep. There are 8 settings possible.

Color change: The 3 buttons (SMOOTH, FADE1, FADE2) let you automatically change the RGB colors (red, green, blue) at different rhythms. The other RGB color buttons let you choose the ambiance color you desire. They can be combined with the orange LEDs or not.



3- With a smart phone app (for Premium & XXL series only, not available for Origin series)

a) Install the app onto your smart phone

If you use Android, search for the AFIRE app on Google-Play.

If you use iOS, search for the AFIRE app or AFIRE fireplace APP on the App Store.

b) Sign up

4- Start the app

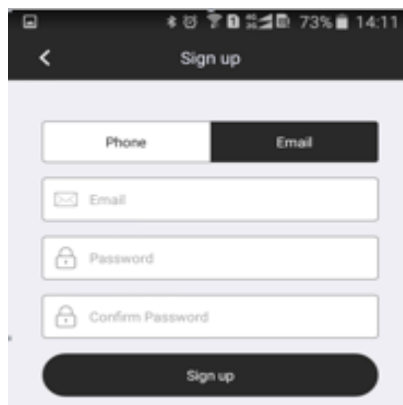

5- Enter your email address and your password. You must use upper and lower-case letters and numbers.

Tap “Sign up”

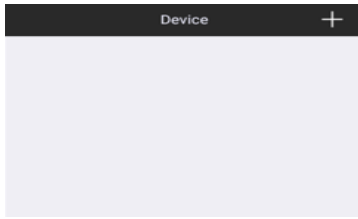

The screen will show “Device”

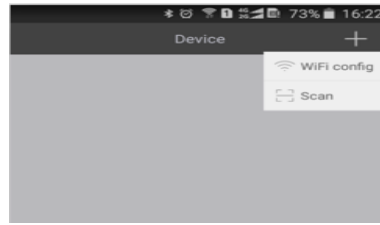

C) Detect your device

1- Tap **+** (at the top right) and then tap **Wifi config** (enter the Wi-Fi password if applicable).

Simultaneously press the On/Off button and button B1 of your fireplace module until they flash. Then, tap the “Start” button on your smartphone screen.

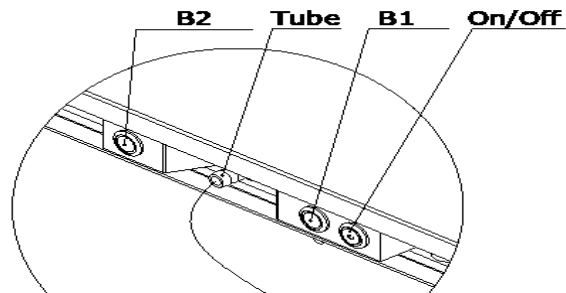
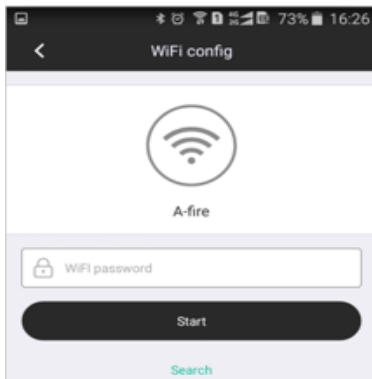

Detection should take 10 to 20 seconds. Your telephone will then indicate that the device has been detected. **Select “Afire” and confirm with the Confirm button on your smartphone screen.**

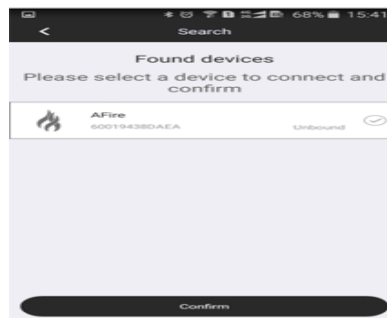

The screen will display the controls available for your device. Enter your password for your Wi-Fi connection and tap “Start.”



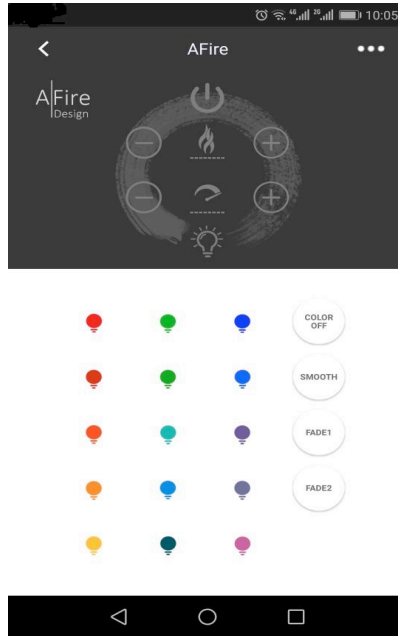

Next, simply tap the AFIRE icon on your smartphone to get to the app function screen. Of course, your Wi-Fi will need to be working.

8. CONNECTING SEVERAL DEVICES TO CREATE A FIRE LINE

Choose one of the devices to be the MASTER receiver. All the other devices will be SLAVES that depend on this MASTER for control. You can choose any of your devices to be the MASTER.

When you receive your devices, they are all MASTERS. Once you choose your MASTER, adjust all the other modules as follows so they will become SLAVES.

Simultaneously hold the On/Off and B2 buttons for 5 seconds. You will hear a short beep and the device is now a SLAVE.

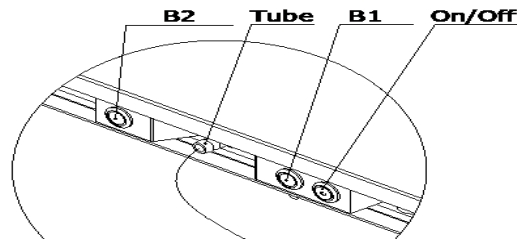

Note that for fireplaces that have several modules, the smartphone app must be registered ONLY for the MASTER.

9: DEVICE MAINTENANCE

All cleaning and maintenance operations must be done with the device switched off. Occasionally clean the visible parts with a soft cloth. Never interfere with the safety or electronic systems. Contact us or an authorized specialist.

Some components are required to ensure the safety and proper operation of the device. Their replacement may modify the performance of your device. Only original components should be used for maintenance or repair operations. This maintenance may only be carried out by authorized specialists. If these instructions are not



followed, our liability will not be incurred. If you plan on moving the device, always do so with the **reservoir emptied**.

Cleaning and maintenance: **If you do not use your device for several weeks, it is very important to empty it in order to prevent the water from becoming stagnant.**

After using for a while, your device may produce less vapor, and as such, reduce the quality of the flames. You should then clean or replace certain worn-out parts, such as the ultrasonic Mist Maker, the lifespan of which is between **2,000 and 3,000 hours** (depending on the hardness and cleanliness of the water used).

To do so, follow this procedure:

- 1** – Switch off your device and remove the top detachable plate.
- 2** – Disconnect the input of the Mist Make and unscrew the drain cap of the Mist Make.
- 3** – Replace the Mist Make or try to clean the white disk with white vinegar (a few drops on the disk for a few minutes to dissolve lime scale).
- 5** - Reassemble.

Clean the air filter on the Mist Make case ventilator. To do this, clean carefully with water, then let dry before reassembly.

10: Warranty

Devices have a limited warranty of two years (from date of purchase).

This limited warranty applies only to the original purchaser of the product and is non-transferable.

Not covered by the warranty: The warranty does not apply to products that have been repaired (unless they were repaired by the manufacturer or an authorized representative). **The warranty does not apply to replaceable parts such as the Ultrasonic Mist Maker.**

This limited warranty does not apply to defects resulting from improper use, **poor cleanliness of the water used**, abuse, accidents, negligence, improper installation, improper maintenance or handling.

For the warranty, defects must be reported to the manufacturer's technical service or its representative. Please provide proof of purchase (receipt) and serial number.

