

MODERN FARMHOUSE DECOR DREAM

**NEW LAMBERT ENTERTAINMENT PACKAGE
ADDITION TO THE ESSENTIAL SERIES OFFERING**



napoleonfireplaces.com

Lambert Electric Entertainment Package

Nothing says comfy cozy quite like the rustic charm of the Lambert Electric Fireplace Mantel package and include soft closing doors with decorative metal plates and elegant door handles. No assembly required, this modern farmhouse dream comes completely assembled, just plug it in and enjoy. A cable management system allows you to keep everything on your media shelf nice and tidy. Complete with the Cinema™ 27 electric insert with up to 5,000 BTU's. The Cinema series electric fireplace is brimming with features including realistic molded logset and ember bed, exclusive LED NIGHT LIGHT™ with 4 color setting options and ready for all season usage by allowing the flames to operate with or without heat.

Lambert Mantel Product Features

- 31 11/6"H X 65 3/8"W X 17 3/4"D
- Complete with Cinema™ 27 electric firebox
- Comes fully assembled - no tools required
- Electronic media compartment with wire management system
- Soft closing doors with decorative accent metal and elegant door handles



Cinema™ 27 Firebox Features

- Up to 5,000 BTUs and 1,500 watts
- Adjustable flame and ember bed light control
- Can be used independently as a NIGHT LIGHT™ on white, blue, orange or cycling settings
- Seven timer settings from 30 minutes up to 6 hours
- Convenient remote control

Features

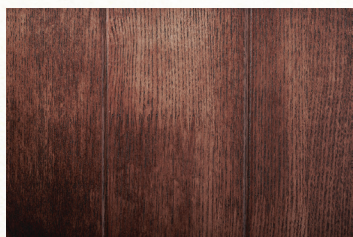

Rustic Wood Finish



Decorative Accent Metal Plates



Control Panel



Shelves



Elegant Hardware



Soft Closing Doors



Cable Management System



Cinema™ 27 Firebox





Remote Control





A COUNTRY STATEMENT PIECE

Whether your current home style is more modern, rustic or transitional the Lambert Entertainment Package will fit right in by blending with current home decor or as a stand out piece. Used decoratively or functionally as a TV stand, it is sure to make an impact by creating more memorable moments in it's new home.

- 

Electric Fireplace
Economical to Operate
- 

Safe To Touch
Never hot enough to burn
- 

Adjustable temperature
Adjust the heat being produced by choosing a temperature
- 

Plug-in
Simply plug in and your fireplace is ready
- 

Eco-Friendly
Only heat the rooms you use most
- 

ULTRA BRIGHT™ LED Lights
Provide day or night intensity
- 

Multi-function remote
Controls flame intensity, flame color option, blower, heat output and timer
- 

WHISPER QUIET™
Operates at a whisper to ensure enjoyment

Specifications

Entertainment Unit Name	Product Code	Firebox	Style	Height	Front Width	Depth
Lambert	NEFP27-0519RW	Cinema 27	Mantel	31 11/16"	65 3/8"	17 3/4"

Firebox Name	Product Code	BTU's (Input)	Watts	Voltage	Amps
Cinema 27	NEFB27H-3A	5,000	1,500	120V AC	15

Certified under Canadian and American National Standards.
 Figures may vary with individual conditions such as floor plan layout, insulation value/heat loss of the house and geographical location.

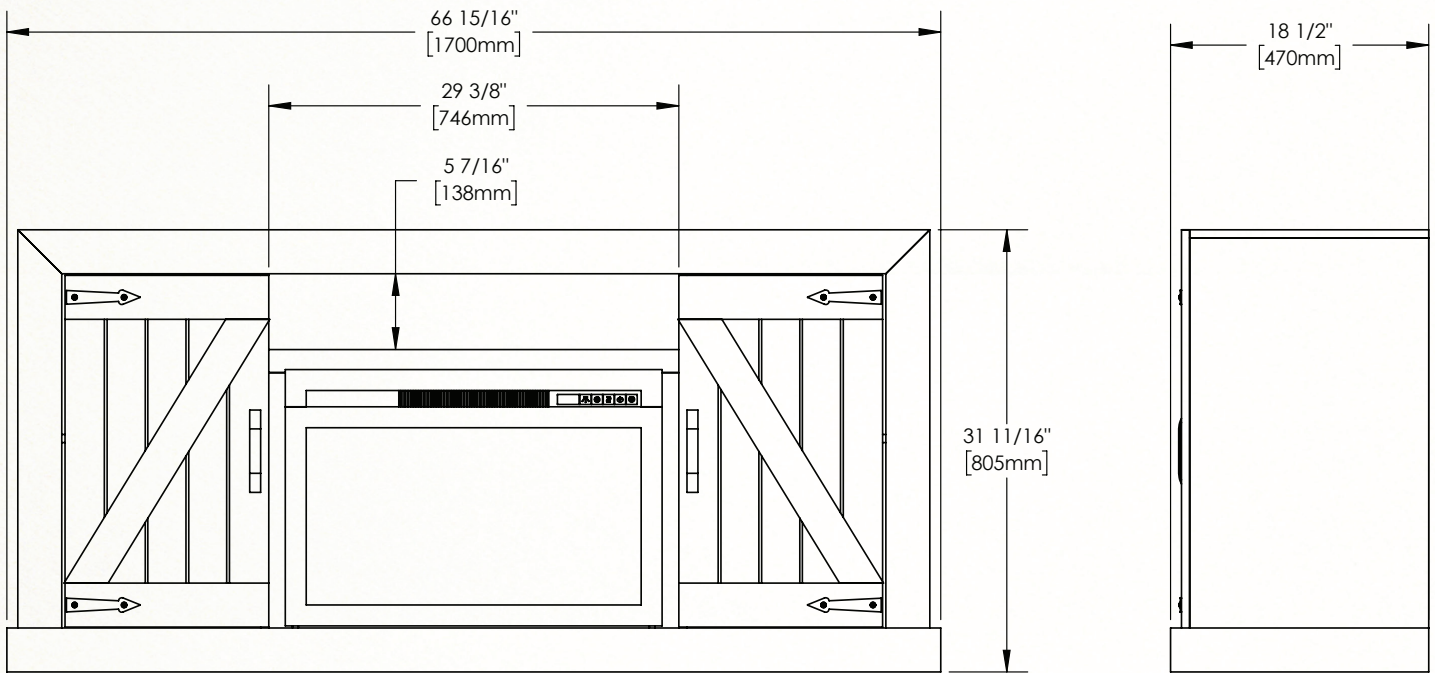

Authorized Dealer

24 Napoleon Road, Barrie, Ontario, Canada L4M 0G8
 103 Miller Drive, Crittenden, Kentucky, USA 41030
 7200 Trans Canada Highway, Montreal, Quebec, Canada H4T 1A3

Tel: 1-866-820-8686
napoleonfireplaces.com



Consult your owner's manual for complete installation instructions and proper clearances to combustible materials. Check all local and national building codes and gas regulations. All specifications are subject to change without prior notice due to on-going product improvements. Products may not be exactly as shown. Napoleon is a registered trademark of Wolf Steel Group Inc.

Printed in Canada
 08/2019