

Specifications

Model	BTU	Width		Height		Depth		Viewing Area
		Actual	Framing	Actual	Framing	Actual	Framing	
NEFBD50HE	5,000 / 10,000	50	49	18 3/8	17 15/16	9	8 / 4 1/2*	43 5/8 x 12

* Deep trim accessory available for 4 1/2" (114mm) thick walls (see "accessories" section of manual).

Dimensions

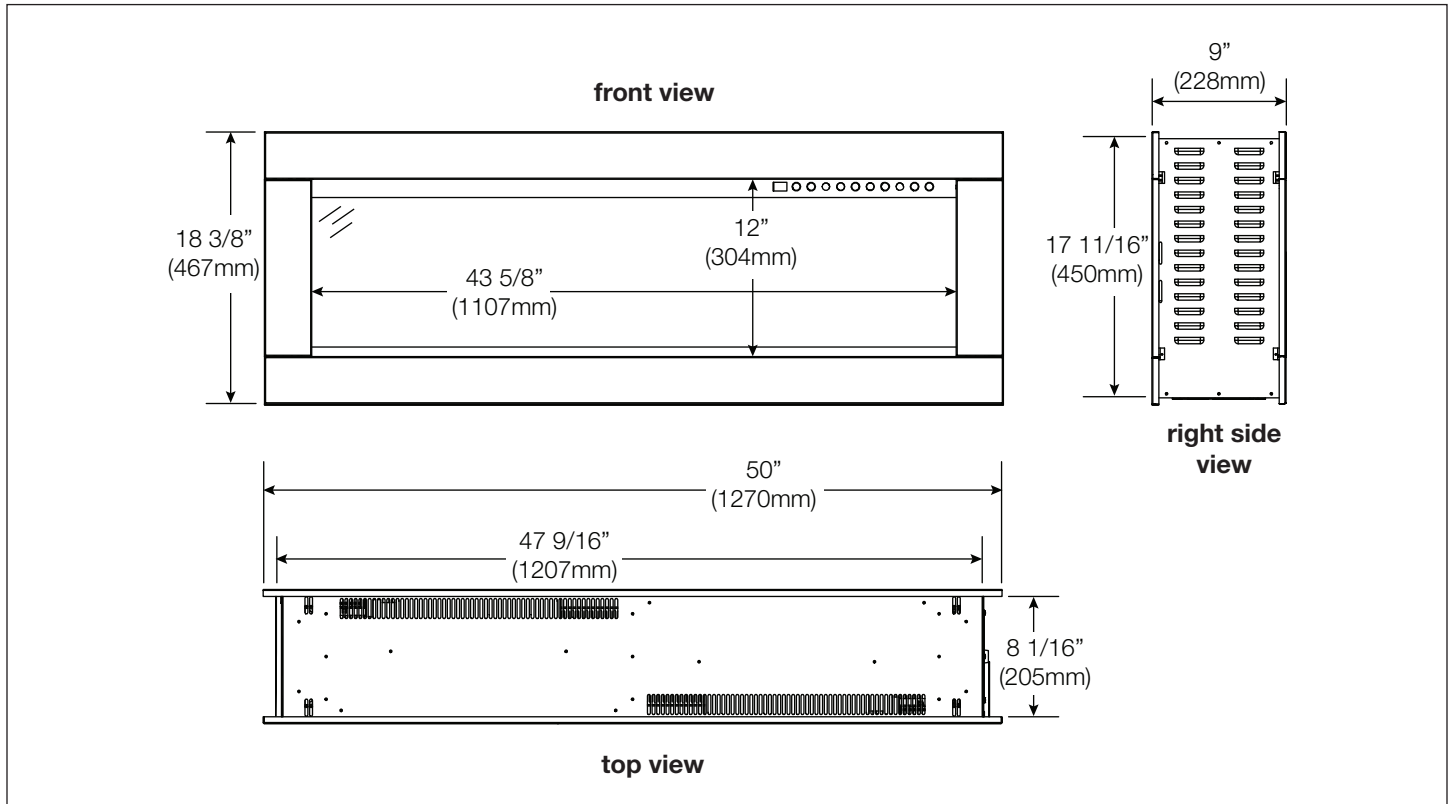

Framing

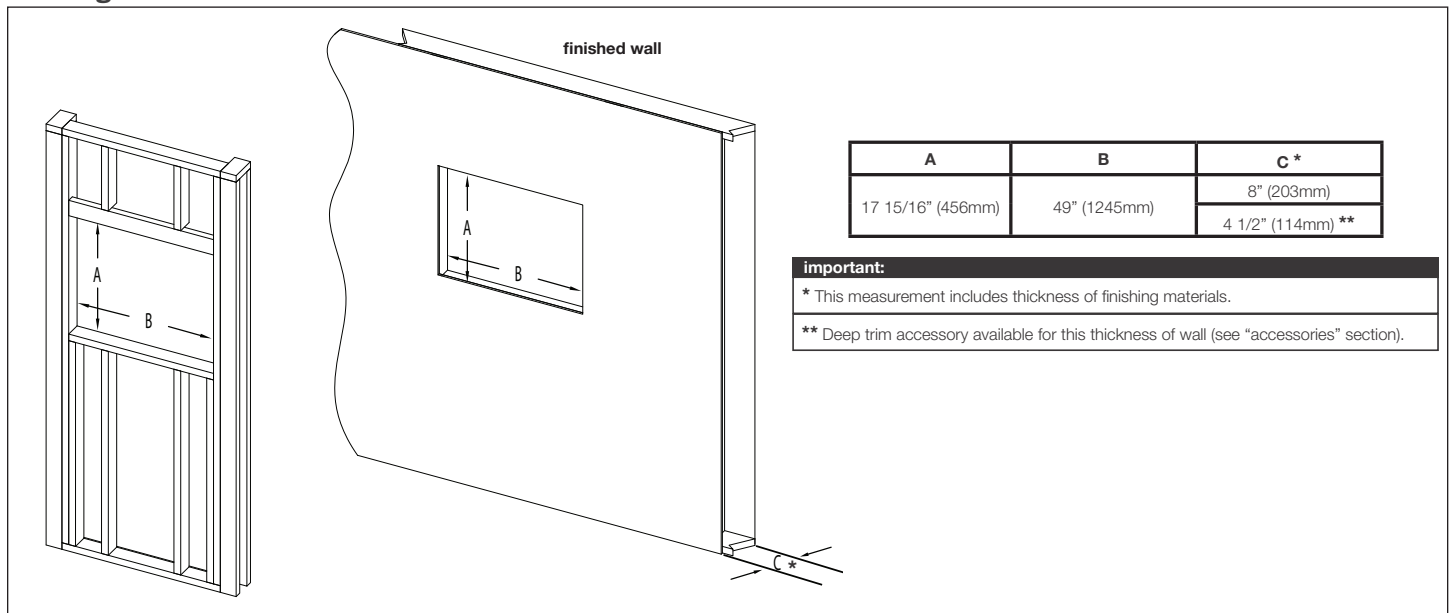

Product information provided is not complete and is subject to change without notice. Please consult the installation manual for the most up to date installation information.

W415-2032 / 09.06.19

Label Location

note:
Labels may not always appear exactly where they are illustrated.

Ref.	Part Number	Description
A*	W385-2235	Locker Label
B*	W385-1946	"Do Not Cover" Label
C*	W385-2017	"Hot Surface" Label
D**	W385-2163	Warning Label
E**	W385-2408	Rating Plate
F**	-	Serial Number Label
G**	W385-2167	Caution Label
H	W385-4513	120V Hard-Wiring Label
I	W385-4514	240V Hard-Wiring Label
J***	W385-4515	Wiring Diagram Label

* Labels located on front and back sides of glass.
** Label located behind trim on front and back sides of appliance.
*** Labels located on back side of trim.

Minimum Mantel Clearances

⚠ WARNING

- When using paint or lacquer to finish the mantel, the paint or lacquer must be heat resistant to prevent discoloration.

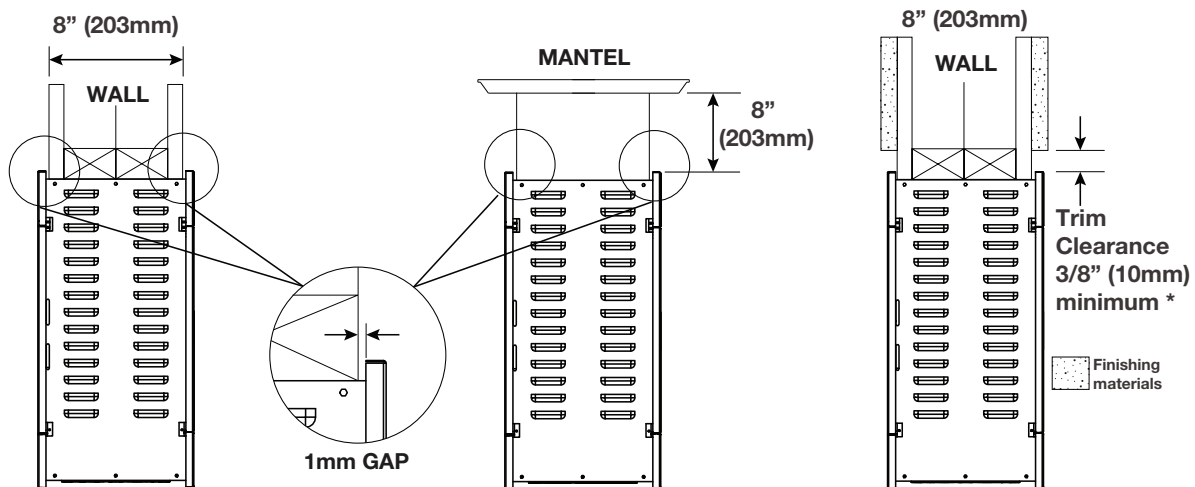

note:

* If finishing materials are installed on top of the already 8" (203mm) wall, a 3/8" (10mm) clearance must be maintained at the top of the trim in order to service the appliance.

CLEARION™ ELITE 60" ELECTRIC APPLIANCE



Specifications

Model	BTU	Width		Height		Depth		Viewing Area
		Actual	Framing	Actual	Framing	Actual	Framing	
NEFBD60HE	5,000 / 10,000	60	59	20 7/16	19 15/16	9 3/16	8 / 4 1/2*	53 1/2 x 14

* Deep trim accessory available for 4 1/2" (114mm) thick walls (see "accessories" section of manual).

Dimensions

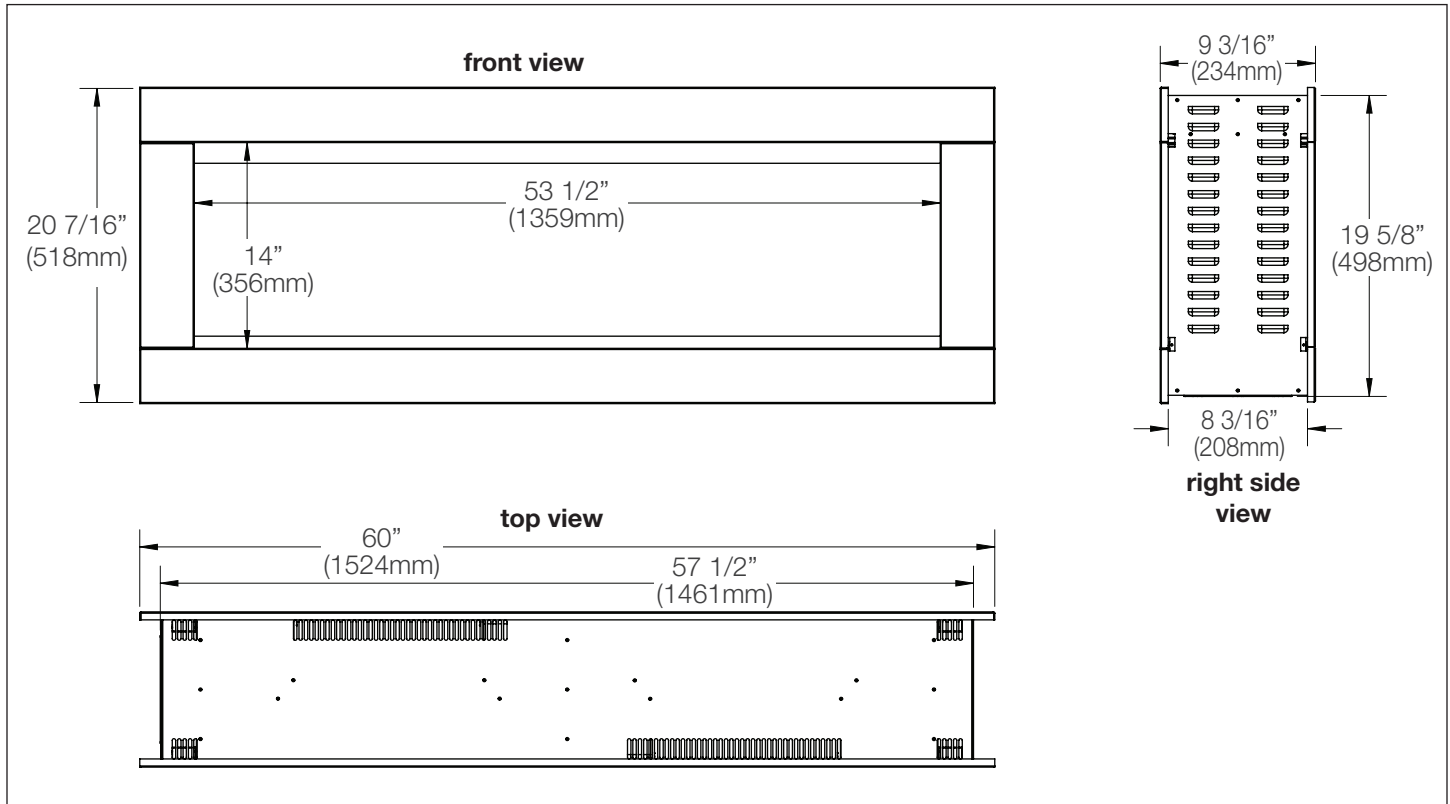

Framing

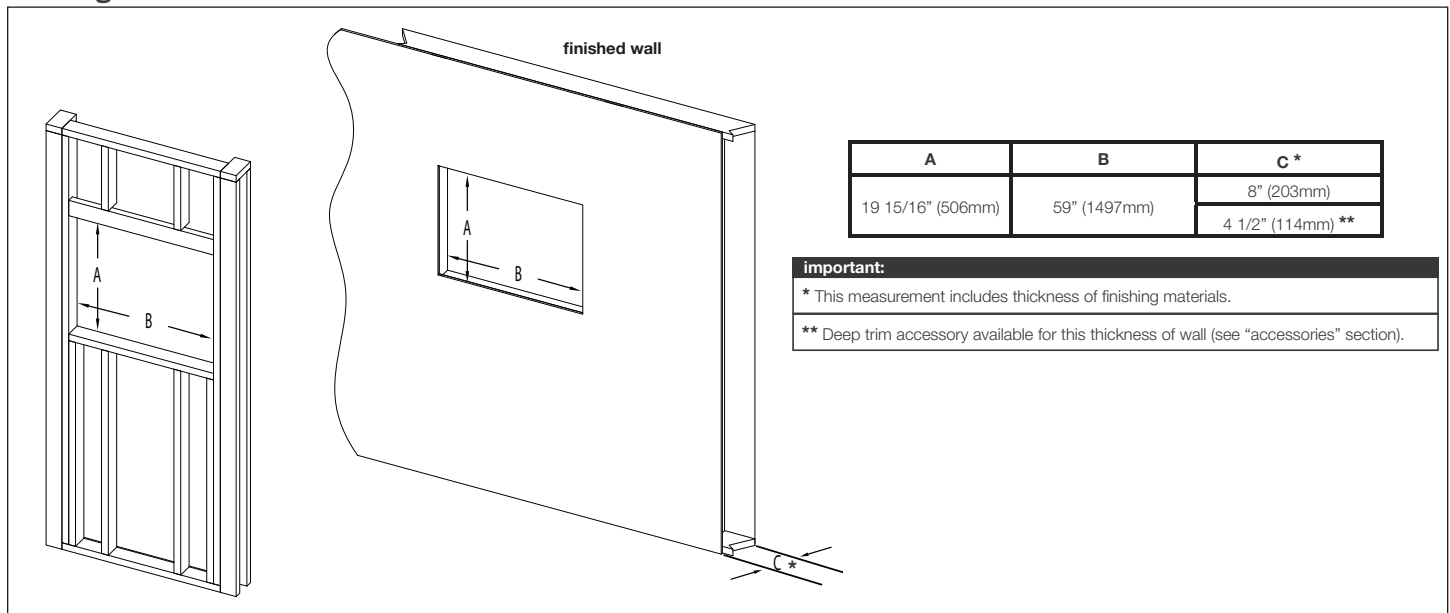

Product information provided is not complete and is subject to change without notice. Please consult the installation manual for the most up to date installation information.

W415-2914 / 04.16.20

Label Location

note:
Labels may not always appear exactly where they are illustrated.

Ref.	Part Number	Description
A*	W385-2235	Locker Label
B*	W385-2210	"Do Not Cover" Label
C*	W385-2017	"Hot Surface" Label
D**	W385-2163	Warning Label
E**	W385-2469	Rating Plate
F**	W385-2167	Caution Label
G	W385-4513	120V Hard-Wiring Label
H	W385-4514	240V Hard-Wiring Label
I***	W385-2477	Wiring Diagram Label

* Labels located on front and back sides of glass.
** Label located behind trim on front and back sides of appliance.
*** Labels located on back side of trim.

Minimum Mantel Clearances

⚠ WARNING

- When using paint or lacquer to finish the mantel, the paint or lacquer must be heat resistant to prevent discoloration.

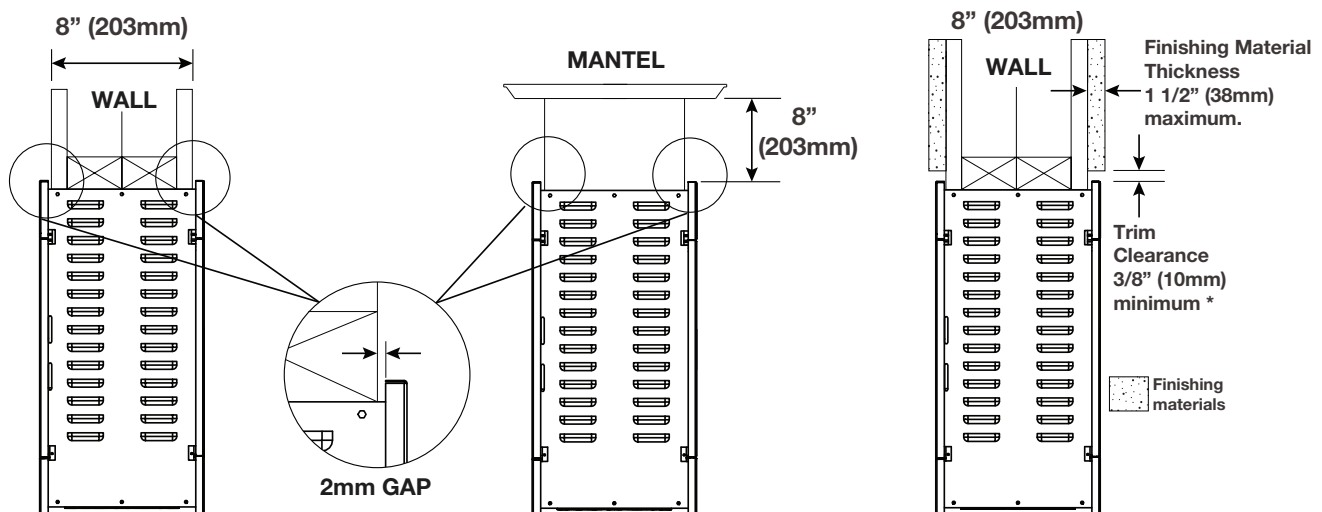

note:

* If finishing materials are installed on top of the already 8" (203mm) wall, a 3/8" (10mm) clearance must be maintained at the top of the trim in order to service the appliance.