

SELECT DESIRED VOLTAGE:

120 V (EW15L12)

240 V (EW32L24)

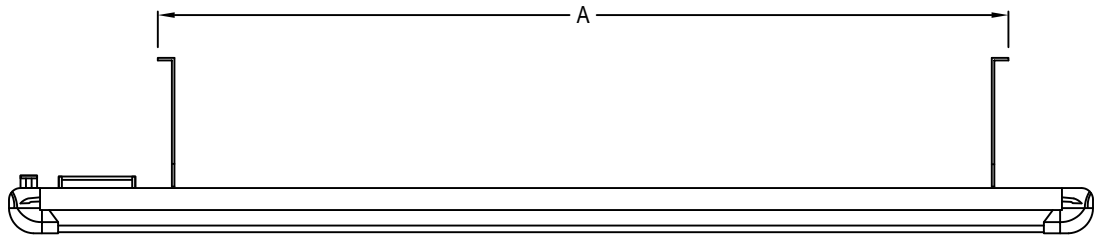
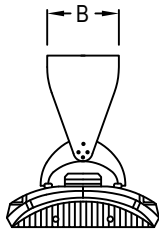
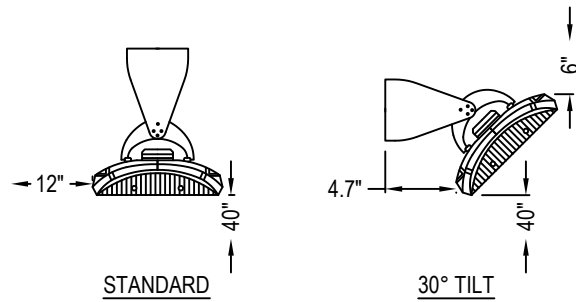

SIDE ELEVATION
SUPPORT MOUNTING DETAIL

FRONT ELEVATION
SUPPORT MOUNTING DETAIL

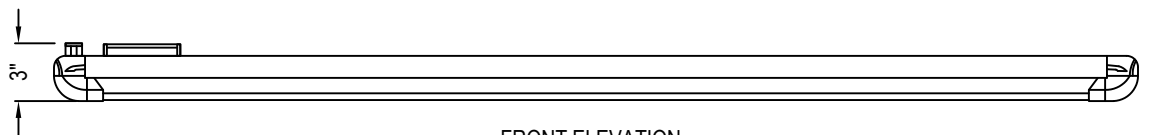
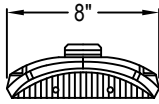

SIDE ELEVATION

FRONT ELEVATION

MODEL	OUTPUT WATTAGE	SUPPLY VOLTAGE	SUPPLY PHASE	SUPPLY AMP DRAW	SUPPLY VOLTAGE/ CONNECTION	DIMENSIONS	WEIGHT	SUPPORT MOUNT A X B
EW15L12	1500 W	120 V	1	12.5A	1Φ2W, 120 VAC	57 X 8 X 3" (145 X 20 X 8 CM)	16.5 LBS (7.5 KG)	47 X 3.8" (120 X 9.6CM)
EW32L24	3200 W	240 V	1	13.3A	1Φ2W, 240VAC	89 X 8 X 3" (226 X 20 X 8 CM)	25.1 LBS (11.4 KG)	70 X 3.8" (180 X 9.6CM)

NOTES:

1. INSTALLATION TO BE COMPLETED IN ACCORDANCE WITH MANUFACTURER'S SPECIFICATIONS.
2. DO NOT SCALE DRAWING.
3. THIS DRAWING IS INTENDED FOR USE BY ARCHITECTS, ENGINEERS, CONTRACTORS, CONSULTANTS AND DESIGN PROFESSIONALS FOR PLANNING PURPOSES ONLY.
4. ALL INFORMATION CONTAINED HEREIN WAS CURRENT AT THE TIME OF DEVELOPMENT BUT MUST BE REVIEWED AND APPROVED BY THE PRODUCT MANUFACTURER TO BE CONSIDERED ACCURATE.
5. CONTRACTOR'S NOTE: FOR PRODUCT AND COMPANY INFORMATION VISIT www.CADdetails.com/info AND ENTER REFERENCE NUMBER 5029-022.