

FORMA FIRE PIT

COPPER, CORTEN STEEL, STAINLESS STEEL, POWDER COATED

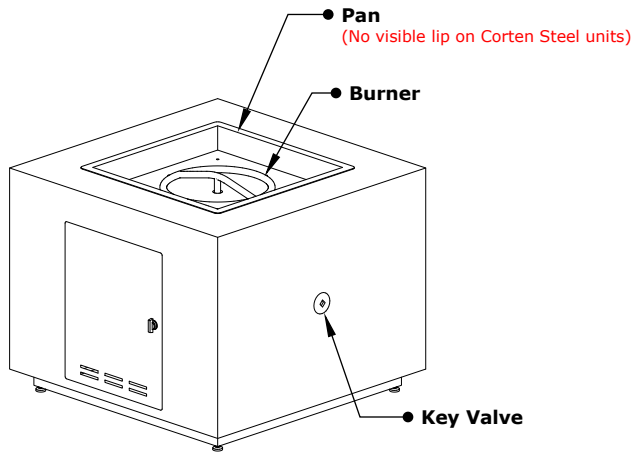

ISOMETRIC VIEW

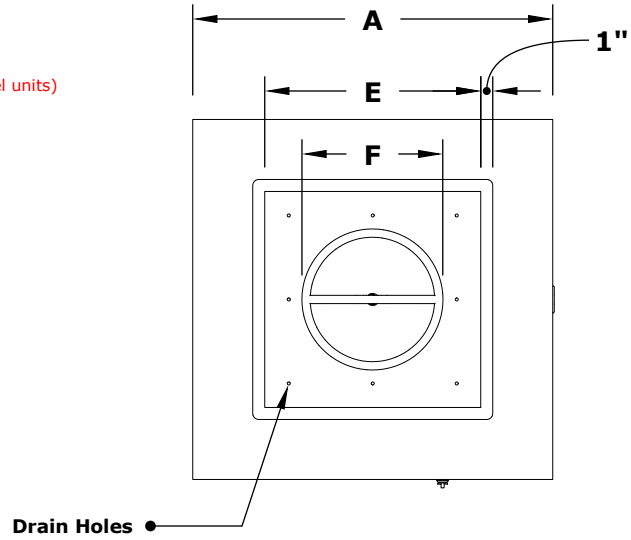

TOP VIEW

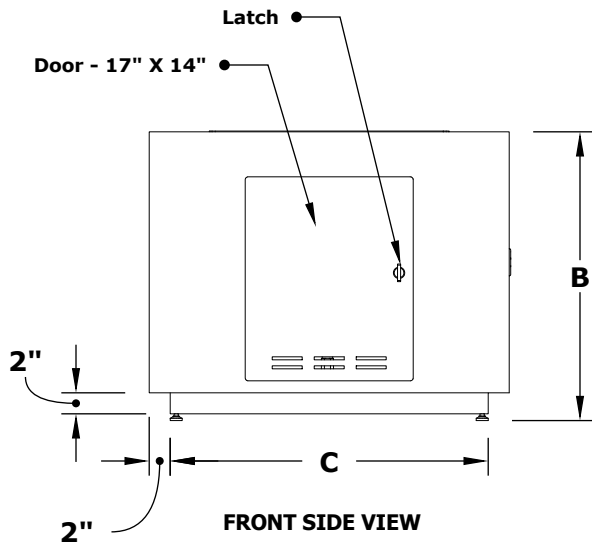

FRONT SIDE VIEW

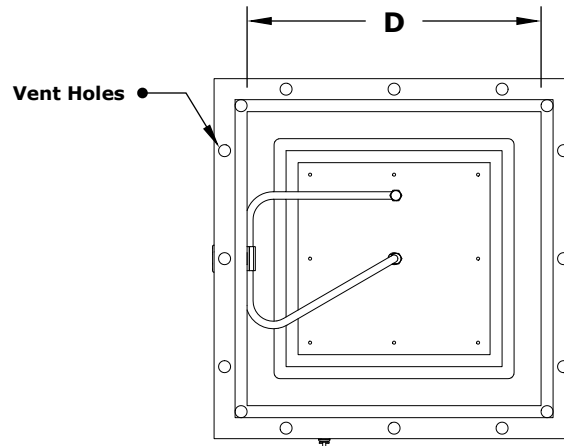

BOTTOM VIEW

COPPER	CORTEN STEEL	STAINLESS STEEL	POWDER COATED	A	B	C	D	E	F	BTU
OPT-3030SQCPR	OPT-3030SQCS	OPT-3030SQSS	OPT-30PCSQ	30"	24"	26"	24"	18"	8"	65,000
OPT-3636SQCPR	OPT-3636SQCS	OPT-3636SQSS	OPT-36PCSQ	36"	24"	32"	30"	24"	12"	65,000
OPT-4242SQCPR	OPT-4242SQCS	OPT-4242SQSS	OPT-42PCSQ	42"	24"	38"	36"	30"	12"	65,000
OPT-4848SQCPR	OPT-4848SQCS	OPT-4848SQSS	OPT-48PCSQ	48"	24"	44"	42"	36"	18"	65,000
OPT-6060SQCPR	OPT-6060SQCS	OPT-6060SQSS	OPT-60PCSQ	60"	24"	56"	54"	48"	18"	65,000
OPT-3030SQCPRK1T	OPT-3030SQCSEK1T	OPT-3030SQSSEK1T	OPT-30PCSQEK1T	30"	24"	26"	24"	18"	8"	65,000
OPT-3636SQCPRK1T	OPT-3636SQCSEK1T	OPT-3636SQSSEK1T	OPT-36PCSQEK1T	36"	24"	32"	30"	24"	12"	65,000
OPT-4242SQCPRK1T	OPT-4242SQCSEK1T	OPT-4242SQSSEK1T	OPT-42PCSQEK1T	42"	24"	38"	36"	30"	12"	65,000
OPT-4848SQCPRK1T	OPT-4848SQCSEK1T	OPT-4848SQSSEK1T	OPT-48PCSQEK1T	48"	24"	44"	42"	36"	18"	65,000
OPT-6060SQCPRK1T	OPT-6060SQCSEK1T	OPT-6060SQSSEK1T	OPT-60PCSQEK1T	60"	24"	56"	54"	48"	18"	65,000

Pan Material: 304 Stainless Steel
 Burner Material: 304 Stainless Steel

Standard 1" Flange on all pans
 Standard 2" Depth on all pans

110V ELECTRONIC IGNITION
 ANSI Z21.97-(2017) / CSA 2.41-(2017)



Match Lit Unit Includes: Pan, Burner, Gas Orifice, Gas Hoses, Key Valve, Key,
 110v Ignition Unit Includes: Pan, Burner, Gas Orifice, Gas Hoses, Key Valve, Key, Plug & Play Electronic Valve, Pilot Igniter.