

Left Corner Fireplaces

Award	2020 BIMsmith Best Award (USA)
Application	Indoor & Outdoor
Materials	Mild Steel (Zinc Sealed), Toughened Glass, Grade 304 Stainless Steel
Colours	Black Firebox, Stainless Steel Burner/s
Fuel Type	e-NRG Bioethanol

FLEX18

ESF.1.FX.18LC

Weight	33kg [72.6lbs] (Incl. burner/s, glass charcoal, glass)
Burner	AB3 x 1
Volume Capacity	2.5 Litres [0.7 Gallons]
Heats on Average (when used indoors)	Over 20 square metres [215 square feet]
Burn Time	8 - 11 hours (approx)
Minimum Room Size	40 cubic metres [1413 cubic feet] per fireplace.
Minimum Wall Length	635mm [25in]

Physical model dimensions should be verified against cut out dimensions BEFORE installation begins to confirm tolerances align.

These values are indicative only and may vary depending on the model purchased, installation, and the seasonal resource used to manufacture e-NRG.

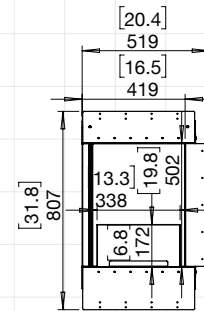

18LC (FLAME ONLY)

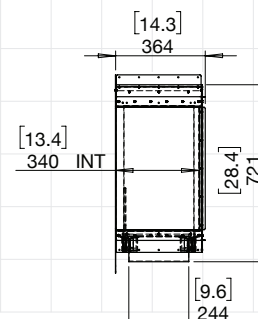

SIDE VIEW

FOR MORE INFORMATION PLEASE REFERENCE THE CLEARANCE & INSTALLATION MANUAL

Disclaimer. All product specifications and data are subject to change without notice and believed to be correct at the time of publication. MAD Design Group (MDG), its affiliates, agents, and employees, and all persons acting on its or their behalf (collectively, "MAD Design Group"), disclaim any and all liability for any errors, inaccuracies or incompleteness contained herein or in any other disclosure relating to any product. MDG disclaims any and all liability arising out of the use or application of any product described herein or of any information provided herein to the maximum extent permitted by law. The product specifications do not expand or otherwise modify MDG's terms and conditions of purchase, including but not limited to the warranty expressed therein, which apply to these products. No license, express or implied, by estoppel or otherwise, to any intellectual property rights is granted by this document or by any conduct of MDG. Customers using or selling MDG products not expressly indicated for use in such applications do so entirely at their own risk and agree to fully indemnify MDG for any damages arising or resulting from such use or sale. Please contact authorised personnel from MDG to obtain written terms and conditions regarding products designed for such applications. Images are indicative only.

Right Corner Fireplaces

Award	2020 BIMsmith Best Award (USA)
Application	Indoor & Outdoor
Materials	Mild Steel (Zinc Sealed), Toughened Glass, Grade 304 Stainless Steel
Colours	Black Firebox, Stainless Steel Burner/s
Fuel Type	e-NRG Bioethanol

FLEX18

ESF.1.FX.18RC

Weight	33kg [72.6lbs] (Incl. burner/s, glass charcoal, glass)
Burner	AB3 x 1
Volume Capacity	2.5 Litres [0.7 Gallons]
Heats on Average (when used indoors)	Over 20 square metres [215 square feet]
Burn Time	8 - 11 hours (approx)
Minimum Room Size	40 cubic metres [1413 cubic feet] per fireplace.
Minimum Wall Length	635mm [25in]

Physical model dimensions should be verified against cut out dimensions BEFORE installation begins to confirm tolerances align.

These values are indicative only and may vary depending on the model purchased, installation, and the seasonal resource used to manufacture e-NRG.

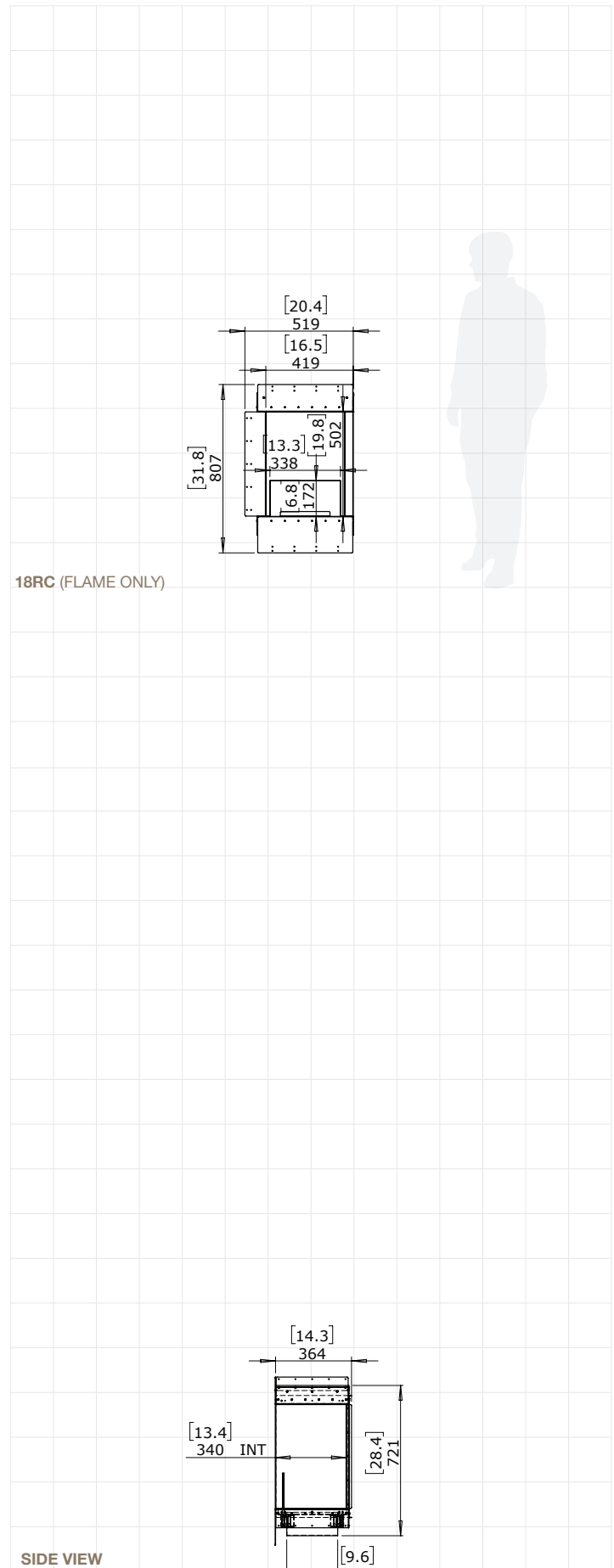

FOR MORE INFORMATION PLEASE REFERENCE THE CLEARANCE & INSTALLATION MANUAL

Disclaimer. All product specifications and data are subject to change without notice and believed to be correct at the time of publication. MAD Design Group (MDG), its affiliates, agents, and employees, and all persons acting on its or their behalf (collectively, "MAD Design Group"), disclaim any and all liability for any errors, inaccuracies or incompleteness contained herein or in any other disclosure relating to any product. MDG disclaims any and all liability arising out of the use or application of any product described herein or of any information provided herein to the maximum extent permitted by law. The product specifications do not expand or otherwise modify MDG's terms and conditions of purchase, including but not limited to the warranty expressed therein, which apply to these products. No license, express or implied, by estoppel or otherwise, to any intellectual property rights is granted by this document or by any conduct of MDG. Customers using or selling MDG products not expressly indicated for use in such applications do so entirely at their own risk and agree to fully indemnify MDG for any damages arising or resulting from such use or sale. Please contact authorised personnel from MDG to obtain written terms and conditions regarding products designed for such applications. Images are indicative only.

LEFT CORNER FIREPLACES

Application	Indoor & Outdoor
Materials	Mild Steel (Zinc Sealed), Toughened Glass, Stainless Steel & Black Glass Charcoal as Decorative Media
Colours	Black Firebox, Stainless Steel Burner/s
Fuel Type	e-NRG Bioethanol

FLEX32

ESF.1.FX.32LC

Weight	48.8kg [107.4lbs] (incl. burner/s, glass charcoal, glass)
Burner	XL500 x 1
Volume Capacity	5 Litres [1.3 Gallons]
Heats on Average (when used indoors)	Over 40 square metres [430.6 square feet]
Burn Time	10 - 13 hours (approx)
Minimum Room Size	80 cubic metres [2825 cubic feet] per fireplace.
Minimum Wall Length	1,015mm [40in]

Physical model dimensions should be verified against cut out dimensions BEFORE installation begins to confirm tolerances align.

These values are indicative only and may vary depending on the model purchased, installation, and the seasonal resource used to manufacture e-NRG.

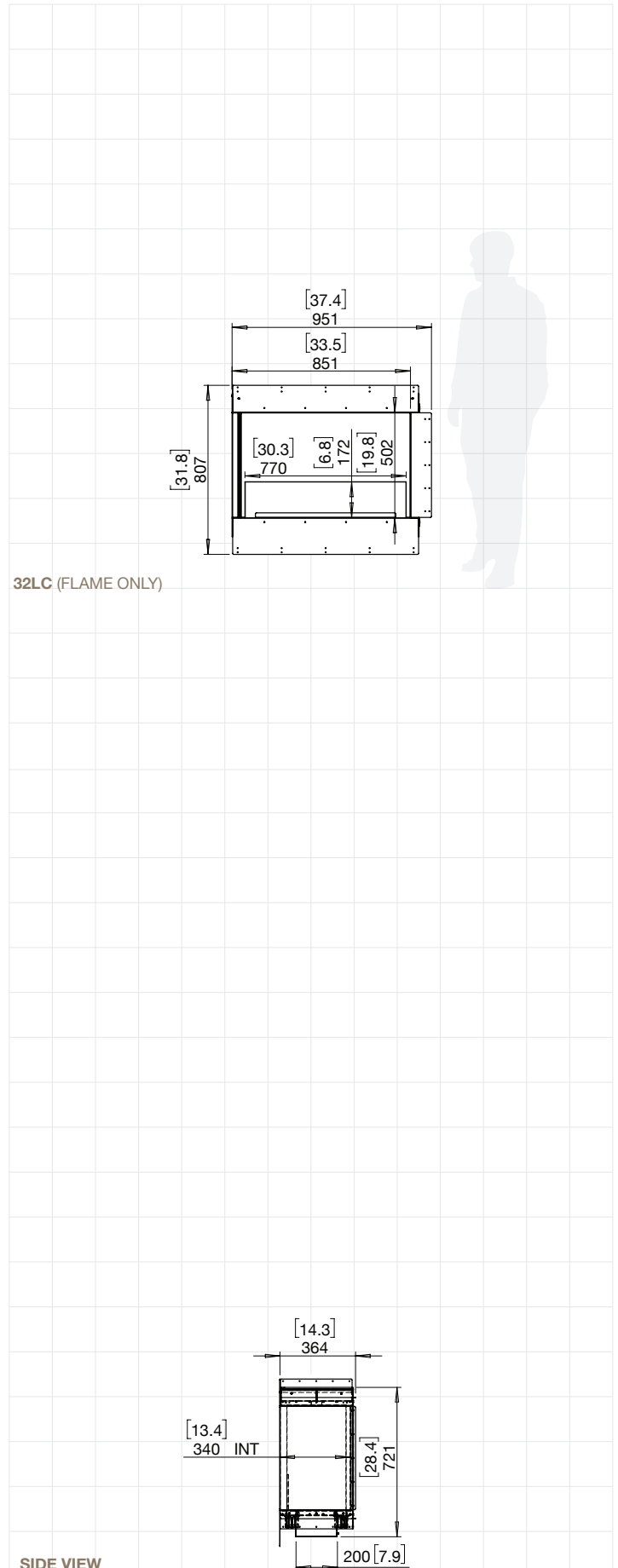

FOR MORE INFORMATION PLEASE REFERENCE THE CLEARANCE & INSTALLATION MANUAL

Disclaimer. All product specifications and data are subject to change without notice and believed to be correct at the time of publication. MAD Design Group (MDG), its affiliates, agents, and employees, and all persons acting on its or their behalf (collectively, "MAD Design Group"), disclaim any and all liability for any errors, inaccuracies or incompleteness contained herein or in any other disclosure relating to any product. MDG disclaims any and all liability arising out of the use or application of any product described herein or of any information provided herein to the maximum extent permitted by law. The product specifications do not expand or otherwise modify MDG's terms and conditions of purchase, including but not limited to the warranty expressed therein, which apply to these products. No license, express or implied, by estoppel or otherwise, to any intellectual property rights is granted by this document or by any conduct of MDG. Customers using or selling MDG products not expressly indicated for use in such applications do so entirely at their own risk and agree to fully indemnify MDG for any damages arising or resulting from such use or sale. Please contact authorized personnel from MDG to obtain written terms and conditions regarding products designed for such applications. Images are indicative only.

Right Corner Fireplaces

Award	2020 BIMsmith Best Award (USA)
Application	Indoor & Outdoor
Materials	Mild Steel (Zinc Sealed), Toughened Glass, Grade 304 Stainless Steel
Colours	Black Firebox, Stainless Steel Burner/s
Fuel Type	e-NRG Bioethanol

FLEX32

ESF.1.FX.32RC

Weight	48.8kg [107.4lbs] (Incl. burner/s, glass charcoal, glass)
Burner	XL500 x 1
Volume Capacity	5 Litres [1.3 Gallons]
Heats on Average (when used indoors)	Over 40 square metres [430.6 square feet]
Burn Time	10 - 13 hours (approx)
Minimum Room Size	80 cubic metres [2825 cubic feet] per fireplace.
Minimum Wall Length	1,015mm [40in]

Physical model dimensions should be verified against cut out dimensions BEFORE installation begins to confirm tolerances align.

These values are indicative only and may vary depending on the model purchased, installation, and the seasonal resource used to manufacture e-NRG.

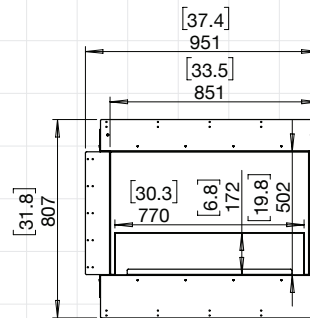

32RC (FLAME ONLY)

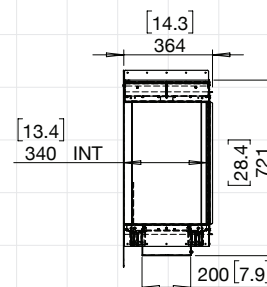

SIDE VIEW

FOR MORE INFORMATION PLEASE REFERENCE THE CLEARANCE & INSTALLATION MANUAL

Disclaimer. All product specifications and data are subject to change without notice and believed to be correct at the time of publication. MAD Design Group (MDG), its affiliates, agents, and employees, and all persons acting on its or their behalf (collectively, "MAD Design Group"), disclaim any and all liability for any errors, inaccuracies or incompleteness contained herein or in any other disclosure relating to any product. MDG disclaims any and all liability arising out of the use or application of any product described herein or of any information provided herein to the maximum extent permitted by law. The product specifications do not expand or otherwise modify MDG's terms and conditions of purchase, including but not limited to the warranty expressed therein, which apply to these products. No license, express or implied, by estoppel or otherwise, to any intellectual property rights is granted by this document or by any conduct of MDG. Customers using or selling MDG products not expressly indicated for use in such applications do so entirely at their own risk and agree to fully indemnify MDG for any damages arising or resulting from such use or sale. Please contact authorised personnel from MDG to obtain written terms and conditions regarding products designed for such applications. Images are indicative only.

LEFT CORNER FIREPLACES

Application	Indoor & Outdoor
Materials	Mild Steel (Zinc Sealed), Toughened Glass, Stainless Steel & Black Glass Charcoal as Decorative Media
Colours	Black Firebox, Stainless Steel Burner/s
Fuel Type	e-NRG Bioethanol

FLEX42

ESF.1.FX.42LC

Weight	63.3kg [139.3lbs] (incl. burner/s, glass charcoal, glass)
Burner	XL700 x 1
Volume Capacity	7 Litres [1.8 Gallons]
Heats on Average (when used indoors)	Over 50 square metres [538 square feet]
Burn Time	9 - 12 hours (approx)
Minimum Room Size	90 cubic metres [3178 cubic feet] per fireplace.
Minimum Wall Length	1,270mm [50in]

Physical model dimensions should be verified against cut out dimensions BEFORE installation begins to confirm tolerances align.

These values are indicative only and may vary depending on the model purchased, installation, and the seasonal resource used to manufacture e-NRG.

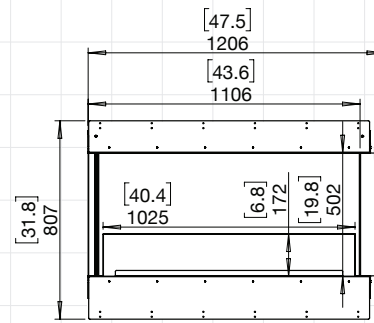

42LC (FLAME ONLY)

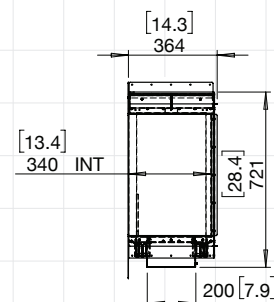

SIDE VIEW

FOR MORE INFORMATION PLEASE REFERENCE THE CLEARANCE & INSTALLATION MANUAL

Disclaimer. All product specifications and data are subject to change without notice and believed to be correct at the time of publication. MAD Design Group (MDG), its affiliates, agents, and employees, and all persons acting on its or their behalf (collectively, "MAD Design Group"), disclaim any and all liability for any errors, inaccuracies or incompleteness contained herein or in any other disclosure relating to any product. MDG disclaims any and all liability arising out of the use or application of any product described herein or of any information provided herein to the maximum extent permitted by law. The product specifications do not expand or otherwise modify MDG's terms and conditions of purchase, including but not limited to the warranty expressed therein, which apply to these products. No license, express or implied, by estoppel or otherwise, to any intellectual property rights is granted by this document or by any conduct of MDG. Customers using or selling MDG products not expressly indicated for use in such applications do so entirely at their own risk and agree to fully indemnify MDG for any damages arising or resulting from such use or sale. Please contact authorized personnel from MDG to obtain written terms and conditions regarding products designed for such applications. Images are indicative only.

Right Corner Fireplaces

Award	2020 BIMsmith Best Award (USA)
Application	Indoor & Outdoor
Materials	Mild Steel (Zinc Sealed), Toughened Glass, Grade 304 Stainless Steel
Colours	Black Firebox, Stainless Steel Burner/s
Fuel Type	e-NRG Bioethanol

FLEX42

ESF.1.FX.42RC

Weight	63.3kg [139.3lbs] (Incl. burner/s, glass charcoal, glass)
Burner	XL700 x 1
Volume Capacity	7 Litres [1.8 Gallons]
Heats on Average (when used indoors)	Over 50 square metres [538 square feet]
Burn Time	9 - 12 hours (approx)
Minimum Room Size	90 cubic metres [3178 cubic feet] per fireplace.
Minimum Wall Length	1,270mm [50in]

Physical model dimensions should be verified against cut out dimensions BEFORE installation begins to confirm tolerances align.

These values are indicative only and may vary depending on the model purchased, installation, and the seasonal resource used to manufacture e-NRG.

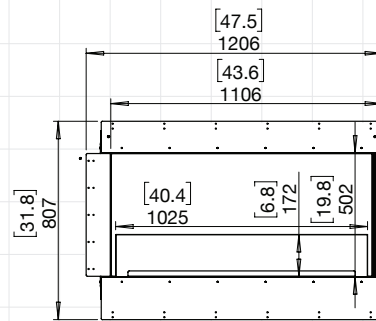

42RC (FLAME ONLY)

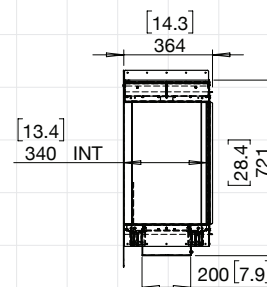

SIDE VIEW

FOR MORE INFORMATION PLEASE REFERENCE THE CLEARANCE & INSTALLATION MANUAL

Disclaimer. All product specifications and data are subject to change without notice and believed to be correct at the time of publication. MAD Design Group (MDG), its affiliates, agents, and employees, and all persons acting on its or their behalf (collectively, "MAD Design Group"), disclaim any and all liability for any errors, inaccuracies or incompleteness contained herein or in any other disclosure relating to any product. MDG disclaims any and all liability arising out of the use or application of any product described herein or of any information provided herein to the maximum extent permitted by law. The product specifications do not expand or otherwise modify MDG's terms and conditions of purchase, including but not limited to the warranty expressed therein, which apply to these products. No license, express or implied, by estoppel or otherwise, to any intellectual property rights is granted by this document or by any conduct of MDG. Customers using or selling MDG products not expressly indicated for use in such applications do so entirely at their own risk and agree to fully indemnify MDG for any damages arising or resulting from such use or sale. Please contact authorised personnel from MDG to obtain written terms and conditions regarding products designed for such applications. Images are indicative only.

Left Corner Fireplaces

Award	2020 BIMsmith Best Award (USA)
Application	Indoor & Outdoor
Materials	Mild Steel (Zinc Sealed), Toughened Glass, Grade 304 Stainless Steel
Colours	Black Firebox, Stainless Steel Burner/s
Fuel Type	e-NRG Bioethanol

FLEX50

ESF.1.FX.50LC

Weight	71.6kg [157.5lbs] (Incl. burner/s, glass charcoal, glass)
Burner	XL900 x 1
Volume Capacity	9 Litres [2.4 Gallons]
Heats on Average (when used indoors)	Over 60 square metres [645 square feet]
Burn Time	8 - 13 hours (approx)
Minimum Room Size	110 cubic metres [3884 cubic feet] per fireplace.
Minimum Wall Length	1,475mm [58in]

ESF.1.FX.50LC.BXL ESF.1.FX.50LC.BXR

Weight	73.1kg [160.8lbs] (Incl. burner/s, glass charcoal, glass)
Burner	XL500 x 1
Volume Capacity	5 Litres [1.3 Gallons]
Heats on Average (when used indoors)	Over 40 square metres [430.6 square feet]
Burn Time	10 - 13 hours (approx)
Minimum Room Size	80 cubic metres [2825 cubic feet] per fireplace.
Minimum Wall Length	1,475mm [58in]

Physical model dimensions should be verified against cut out dimensions BEFORE installation begins to confirm tolerances align.

These values are indicative only and may vary depending on the model purchased, installation, and the seasonal resource used to manufacture e-NRG.

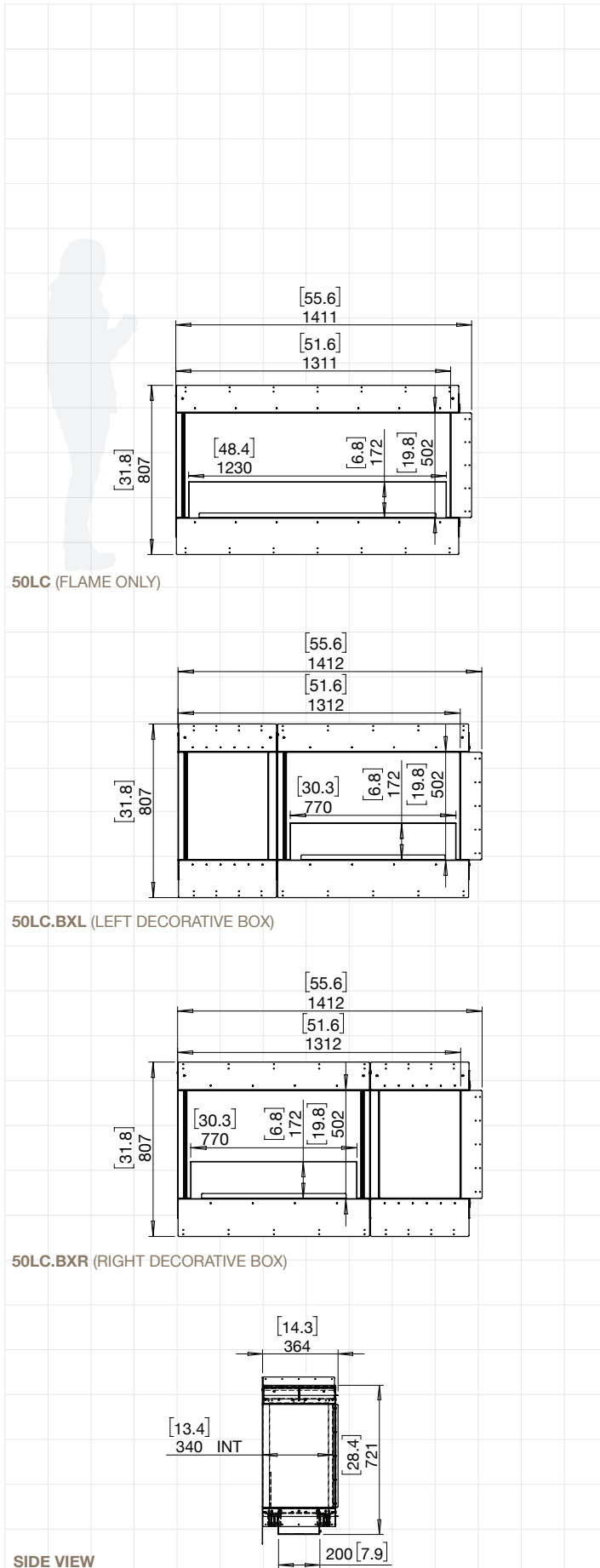

FOR MORE INFORMATION PLEASE REFERENCE THE CLEARANCE & INSTALLATION MANUAL

Disclaimer: All product specifications and data are subject to change without notice and believed to be correct at the time of publication. MAD Design Group (MDG), its affiliates, agents, and employees, and all persons acting on its or their behalf (collectively, "MAD Design Group"), disclaim any and all liability for any errors, inaccuracies or incompleteness contained herein or in any other disclosure relating to any product. MDG disclaims any and all liability arising out of the use or application of any product described herein or of any information provided herein to the maximum extent permitted by law. The product specifications do not expand or otherwise modify MDG's terms and conditions of purchase, including but not limited to the warranty expressed therein, which apply to these products. No license, express or implied, by estoppel or otherwise, to any intellectual property rights is granted by this document or by any conduct of MDG. Customers using or selling MDG products not expressly indicated for use in such applications do so entirely at their own risk and agree to fully indemnify MDG for any damages arising or resulting from such use or sale. Please contact authorised personnel from MDG to obtain written terms and conditions regarding products designed for such applications. Images are indicative only.

RIGHT CORNER FIREPLACES

Application	Indoor & Outdoor
Materials	Mild Steel (Zinc Sealed), Toughened Glass, Stainless Steel & Black Glass Charcoal as Decorative Media
Colours	Black Firebox, Stainless Steel Burner/s
Fuel Type	e-NRG Bioethanol

FLEX50

ESF.1.FX.50RC

Weight	71.6kg [157.5lbs] (incl. burner/s, glass charcoal, glass)
Burner	XL900 x 1
Volume Capacity	9 Litres [2.4 Gallons]
Heats on Average (when used indoors)	Over 60 square metres [645 square feet]
Burn Time	8 - 13 hours (approx)
Minimum Room Size	110 cubic metres [3884 cubic feet] per fireplace.
Minimum Wall Length	1,475mm [58in]

ESF.1.FX.50RC.BXL ESF.1.FX.50RC.BXR

Weight	73.1kg [160.8lbs] (incl. burner/s, glass charcoal, glass)
Burner	XL500 x 1
Volume Capacity	5 Litres [1.3 Gallons]
Heats on Average (when used indoors)	Over 40 square metres [430.6 square feet]
Burn Time	10 - 13 hours (approx)
Minimum Room Size	80 cubic metres [2825 cubic feet] per fireplace.
Minimum Wall Length	1,475mm [58in]

Physical model dimensions should be verified against cut out dimensions BEFORE installation begins to confirm tolerances align.

These values are indicative only and may vary depending on the model purchased, installation, and the seasonal resource used to manufacture e-NRG.

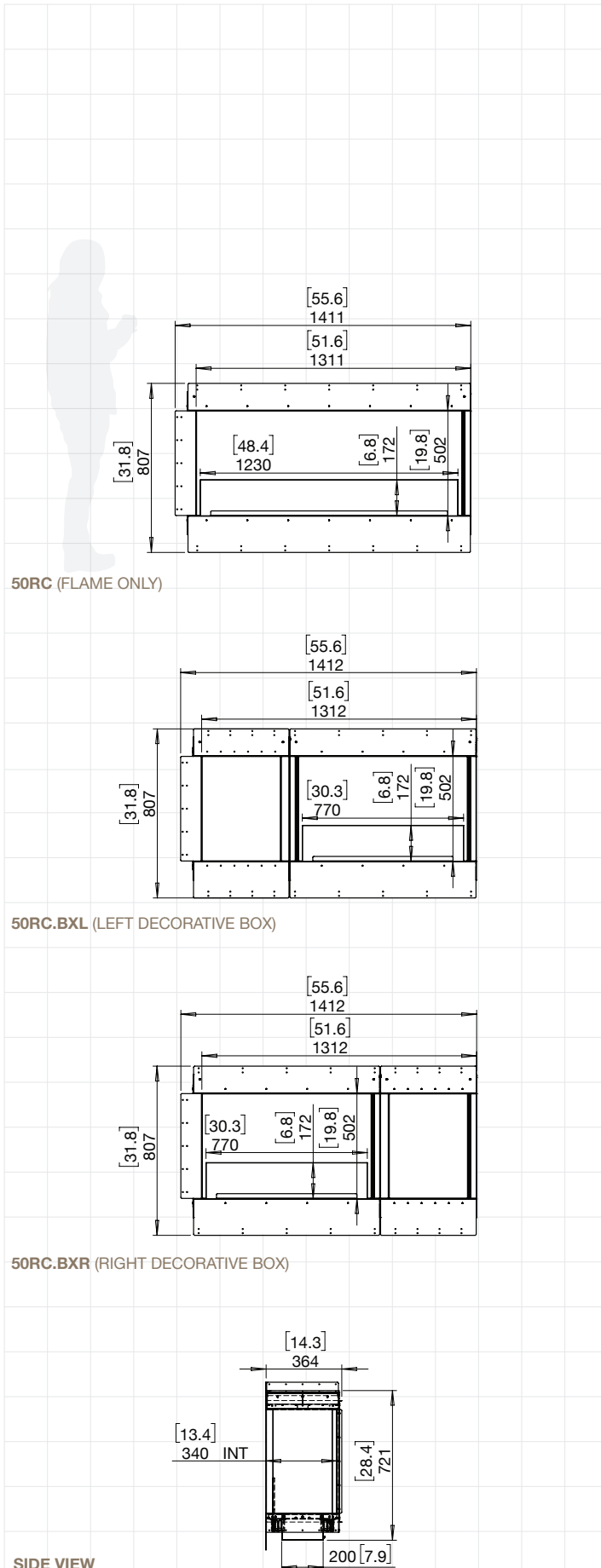

FOR MORE INFORMATION PLEASE REFERENCE THE CLEARANCE & INSTALLATION MANUAL

Disclaimer: All product specifications and data are subject to change without notice and believed to be correct at the time of publication. MAD Design Group (MDG), its affiliates, agents, and employees, and all persons acting on its or their behalf (collectively, "MAD Design Group"), disclaim any and all liability for any errors, inaccuracies or incompleteness contained herein or in any other disclosure relating to any product. MDG disclaims any and all liability arising out of the use or application of any product described herein or of any information provided herein to the maximum extent permitted by law. The product specifications do not expand or otherwise modify MDG's terms and conditions of purchase, including but not limited to the warranty expressed therein, which apply to these products. No license, express or implied, by estoppel or otherwise, to any intellectual property rights is granted by this document or by any conduct of MDG. Customers using or selling MDG products not expressly indicated for use in such applications do so entirely at their own risk and agree to fully indemnify MDG for any damages arising or resulting from such use or sale. Please contact authorised personnel from MDG to obtain written terms and conditions regarding products designed for such applications. Images are indicative only.

LEFT CORNER FIREPLACES

Application	Indoor & Outdoor
Materials	Mild Steel (Zinc Sealed), Toughened Glass, Stainless Steel & Black Glass Charcoal as Decorative Media
Colours	Black Firebox, Stainless Steel Burner/s
Fuel Type	e-NRG Bioethanol

FLEX68

ESF.2.FX.68LC

Weight	100.3kg [220.7lbs] (Incl. burner/s, glass charcoal, glass)
Burner	XL1200 x 1
Volume Capacity	10 Litres [2.6 Gallons] x 1
Heats on Average	Over 65 square metres [700 square feet]
Burn Time	9 - 14 hours (approx)
Minimum Room Size	115 cubic metres [4061 cubic feet] per fireplace
Minimum Wall Length	1,935mm [76in]

ESF.1.FX.68LC.BX2

Weight	97kg [213.4lbs] (Incl. burner/s, glass charcoal, glass)
Burner	XL500 x 1
Volume Capacity	5 Litres [1.3 Gallons]
Heats on Average	Over 40 square metres [430.6 square feet]
Burn Time	10 - 13 hours (approx)
Minimum Room Size	80 cubic metres [2825 cubic feet] per fireplace.
Minimum Wall Length	1,935mm [76in]

ESF.1.FX.68LC.BXL ESF.1.FX.68LC.BXR

Weight	95.3kg [209.7lbs] (Incl. burner/s, glass charcoal, glass)
Burner	XL900 x 1
Volume Capacity	9 Litres [2.4 Gallons]
Heats on Average	Over 60 square metres [645 square feet]
Burn Time	8 - 13 hours (approx)
Minimum Room Size	110 cubic metres [3884 cubic feet] per fireplace.
Minimum Wall Length	1,935mm [76in]

Physical model dimensions should be verified against cut out dimensions BEFORE installation begins to confirm tolerances align.

These values are indicative only and may vary depending on the model purchased, installation, and the seasonal resource used to manufacture e-NRG.

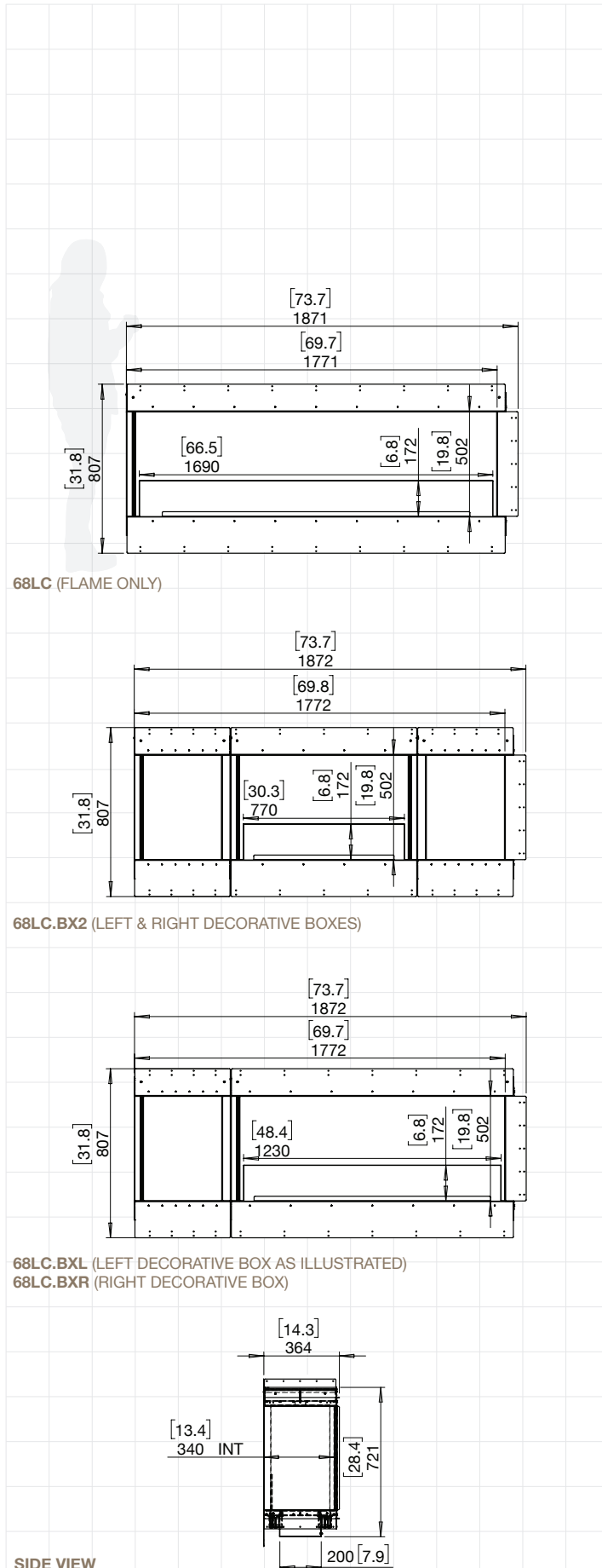

FOR MORE INFORMATION PLEASE REFERENCE THE CLEARANCE & INSTALLATION MANUAL

Disclaimer: All product specifications and data are subject to change without notice and believed to be correct at the time of publication. MAD Design Group (MDG), its affiliates, agents, and employees, and all persons acting on its or their behalf (collectively, "MAD Design Group"), disclaim any and all liability for any errors, inaccuracies or incompleteness contained herein or in any other disclosure relating to any product. MDG disclaims any and all liability arising out of the use or application of any product described herein or of any information provided herein to the maximum extent permitted by law. The product specifications do not expand or otherwise modify MDG's terms and conditions of purchase, including but not limited to the warranty expressed therein, which apply to these products. No license, express or implied, by estoppel or otherwise, to any intellectual property rights is granted by this document or by any conduct of MDG. Customers using or selling MDG products not expressly indicated for use in such applications do so entirely at their own risk and agree to fully indemnify MDG for any damages arising or resulting from such use or sale. Please contact authorized personnel from MDG to obtain written terms and conditions regarding products designed for such applications. Images are indicative only.

RIGHT CORNER FIREPLACES

Application	Indoor & Outdoor
Materials	Mild Steel (Zinc Sealed), Toughened Glass, Stainless Steel & Black Glass Charcoal as Decorative Media
Colours	Black Firebox, Stainless Steel Burner/s
Fuel Type	e-NRG Bioethanol

FLEX68

ESF.2.FX.68RC

Weight	100.3kg [220.7lbs] (incl. burner/s, glass charcoal, glass)
Burner	XL1200 x 1
Volume Capacity	10 Litres [2.6 Gallons] x 1
Heats on Average	Over 65 square metres [700 square feet]
Burn Time	9 - 14 hours (approx)
Minimum Room Size	115 cubic metres [4061 cubic feet] per fireplace
Minimum Wall Length	1,935mm [76in]

ESF.1.FX.68RC.BX2

Weight	97.0kg [213.4lbs] (incl. burner/s, glass charcoal, glass)
Burner	XL500 x 1
Volume Capacity	5 Litres [1.3 Gallons]
Heats on Average	Over 40 square metres [430.6 square feet]
Burn Time	10 - 13 hours (approx)
Minimum Room Size	80 cubic metres [2825 cubic feet] per fireplace.
Minimum Wall Length	1,935mm [76in]

ESF.1.FX.68RC.BXL ESF.1.FX.68RC.BXR

Weight	95.3kg [209.7lbs] (incl. burner/s, glass charcoal, glass)
Burner	XL900 x 1
Volume Capacity	9 Litres [2.4 Gallons]
Heats on Average	Over 60 square metres [645 square feet]
Burn Time	8 - 13 hours (approx)
Minimum Room Size	110 cubic metres [3884 cubic feet] per fireplace.
Minimum Wall Length	1,935mm [76in]

Physical model dimensions should be verified against cut out dimensions BEFORE installation begins to confirm tolerances align.

These values are indicative only and may vary depending on the model purchased, installation, and the seasonal resource used to manufacture e-NRG.

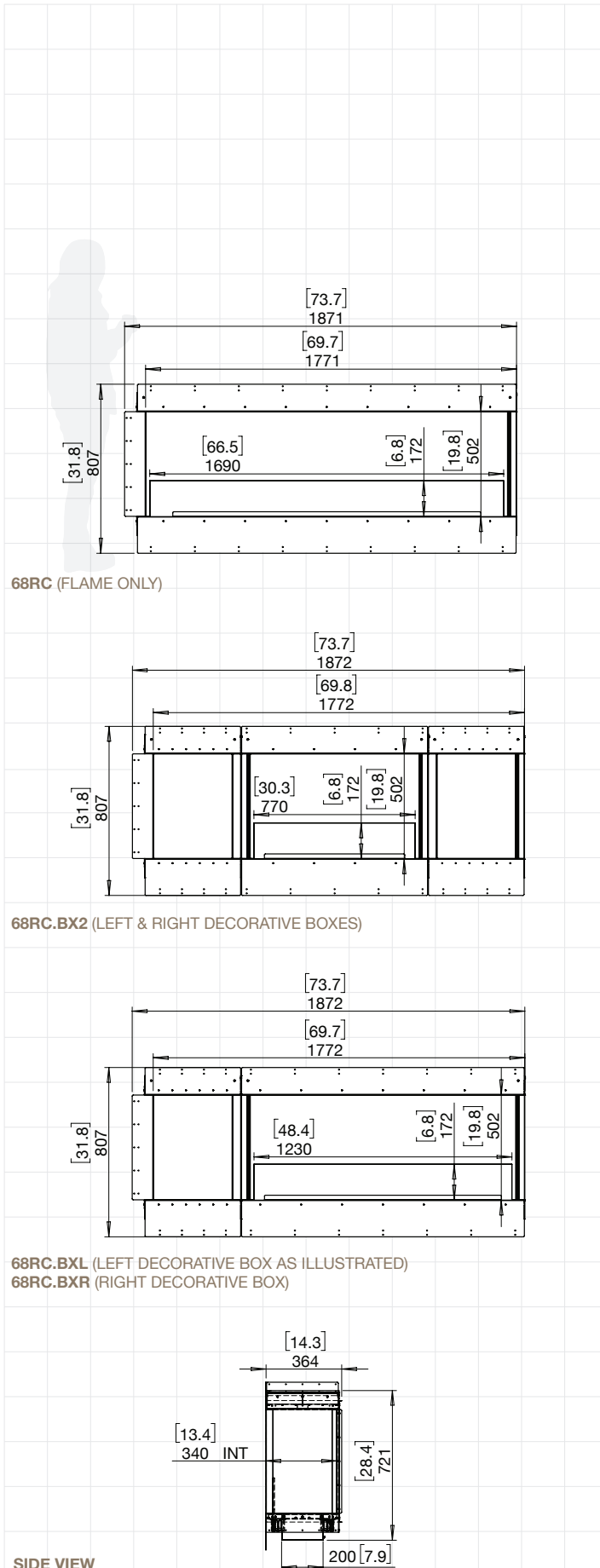

FOR MORE INFORMATION PLEASE REFERENCE THE CLEARANCE & INSTALLATION MANUAL

Disclaimer: All product specifications and data are subject to change without notice and believed to be correct at the time of publication. MAD Design Group (MDG), its affiliates, agents, and employees, and all persons acting on its or their behalf (collectively, "MAD Design Group"), disclaim any and all liability for any errors, inaccuracies or incompleteness contained herein or in any other disclosure relating to any product. MDG disclaims any and all liability arising out of the use or application of any product described herein or of any information provided herein to the maximum extent permitted by law. The product specifications do not expand or otherwise modify MDG's terms and conditions of purchase, including but not limited to the warranty expressed therein, which apply to these products. No license, express or implied, by estoppel or otherwise, to any intellectual property rights is granted by this document or by any conduct of MDG. Customers using or selling MDG products not expressly indicated for use in such applications do so entirely at their own risk and agree to fully indemnify MDG for any damages arising or resulting from such use or sale. Please contact authorised personnel from MDG to obtain written terms and conditions regarding products designed for such applications. Images are indicative only.

LEFT CORNER FIREPLACES

Application	Indoor & Outdoor
Materials	Mild Steel (Zinc Sealed), Toughened Glass, Stainless Steel & Black Glass Charcoal as Decorative Media
Colours	Black Firebox, Stainless Steel Burner/s
Fuel Type	e-NRG Bioethanol

FLEX86

ESF.1.FX.86LC

Weight	121.7kg [267.7lbs] (Incl. burner/s, glass charcoal, glass)
Burner	XL900 x 2
Volume Capacity	9 Litres [2.4 Gallons] x 2
Heats on Average	Over 120 square metres [1290 square feet]
Burn Time	8 - 13 hours (approx)
Minimum Room Size	220 cubic metres [7768 cubic feet] per fireplace
Minimum Wall Length	2,395mm [94in]

ESF.1.FX.86LC.BX2

Weight	119kg [261.8lbs] (Incl. burner/s, glass charcoal, glass)
Burner	XL900 x 1
Volume Capacity	9 Litres [2.4 Gallons]
Heats on Average	Over 60 square metres [645 square feet]
Burn Time	8 - 13 hours (approx)
Minimum Room Size	110 cubic metres [3884 cubic feet] per fireplace
Minimum Wall Length	2,395mm [94in]

ESF.2.FX.86LC.BXL ESF.2.FX.86LC.BXR

Weight	122.6kg [269.7lbs] (Incl. burner/s, glass charcoal, glass)
Burner	XL1200 x 1
Volume Capacity	10 Litres [2.6 Gallons] x 1
Heats on Average	Over 65 square metres [700 square feet]
Burn Time	9 - 14 hours (approx)
Minimum Room Size	115 cubic metres [4061 cubic feet] per fireplace
Minimum Wall Length	2,395mm [94in]

Physical model dimensions should be verified against cut out dimensions BEFORE installation begins to confirm tolerances align.

These values are indicative only and may vary depending on the model purchased, installation, and the seasonal resource used to manufacture e-NRG.

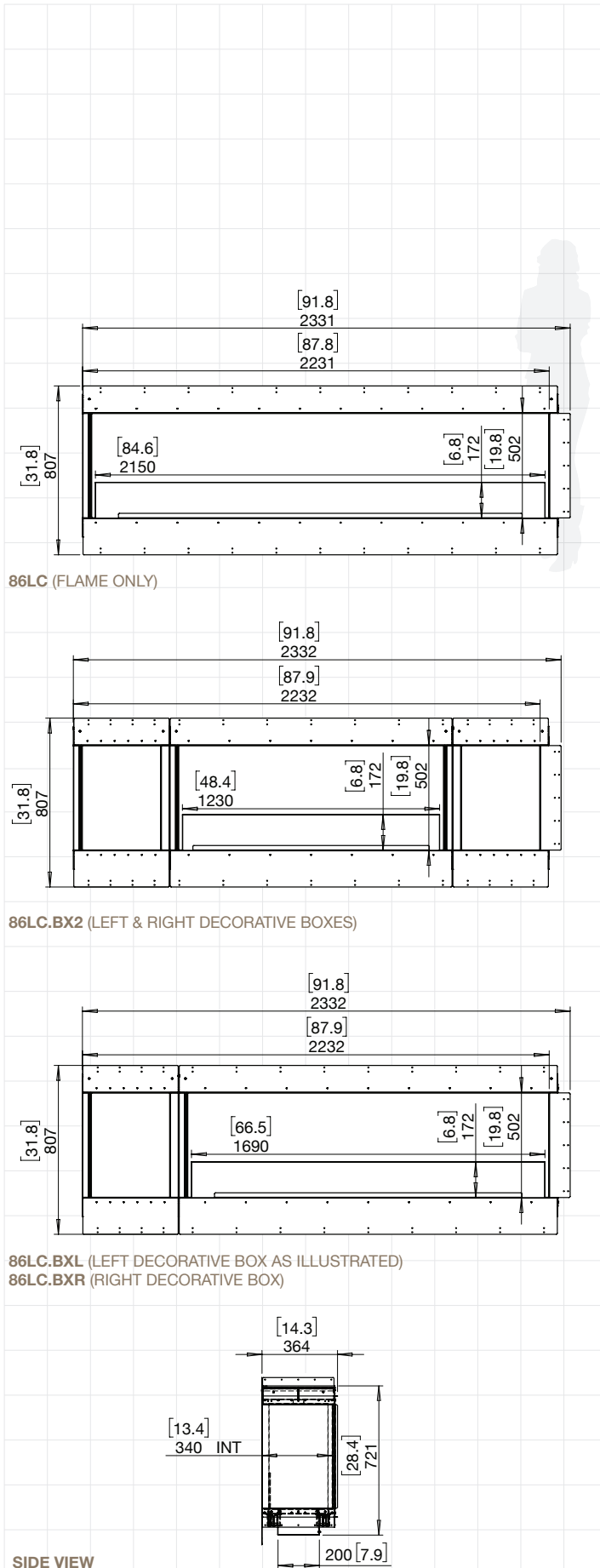

SIDE VIEW

FOR MORE INFORMATION PLEASE REFERENCE THE CLEARANCE & INSTALLATION MANUAL

Disclaimer: All product specifications and data are subject to change without notice and believed to be correct at the time of publication. MAD Design Group (MDG), its affiliates, agents, and employees, and all persons acting on its or their behalf (collectively, "MAD Design Group"), disclaim any and all liability for any errors, inaccuracies or incompleteness contained herein or in any other disclosure relating to any product. MDG disclaims any and all liability arising out of the use or application of any product described herein or of any information provided herein to the maximum extent permitted by law. The product specifications do not expand or otherwise modify MDG's terms and conditions of purchase, including but not limited to the warranty expressed therein, which apply to these products. No license, express or implied, by estoppel or otherwise, to any intellectual property rights is granted by this document or by any conduct of MDG. Customers using or selling MDG products not expressly indicated for use in such applications do so entirely at their own risk and agree to fully indemnify MDG for any damages arising or resulting from such use or sale. Please contact authorised personnel from MDG to obtain written terms and conditions regarding products designed for such applications. Images are indicative only.

Right Corner Fireplaces

Award	2020 BIMsmith Best Award (USA)
Application	Indoor & Outdoor
Materials	Mild Steel (Zinc Sealed), Toughened Glass, Grade 304 Stainless Steel
Colours	Black Firebox, Stainless Steel Burner/s
Fuel Type	e-NRG Bioethanol

FLEX86

ESF.1.FX.86RC

Weight	121.7kg [267.7lbs] (Incl. burner/s, glass charcoal, glass)
Burner	XL900 x 2
Volume Capacity	9 Litres [2.4 Gallons] x 2
Heats on Average	Over 120 square metres [1290 square feet]
Burn Time	8 - 13 hours (approx)
Minimum Room Size	220 cubic metres [7768 cubic feet] per fireplace
Minimum Wall Length	2,395mm [94in]

ESF.1.FX.86RC.BX2

Weight	119kg [261.8lbs] (Incl. burner/s, glass charcoal, glass)
Burner	XL900 x 1
Volume Capacity	9 Litres [2.4 Gallons]
Heats on Average	Over 60 square metres [645 square feet]
Burn Time	8 - 13 hours (approx)
Minimum Room Size	110 cubic metres [3884 cubic feet] per fireplace
Minimum Wall Length	2,395mm [94in]

ESF.2.FX.86RC.BXL ESF.2.FX.86RC.BXR

Weight	122.6kg [269.7lbs] (Incl. burner/s, glass charcoal, glass)
Burner	XL1200 x 1
Volume Capacity	10 Litres [2.6 Gallons] x 1
Heats on Average	Over 65 square metres [700 square feet]
Burn Time	9 - 14 hours (approx)
Minimum Room Size	115 cubic metres [4061 cubic feet] per fireplace
Minimum Wall Length	2,395mm [94in]

Physical model dimensions should be verified against cut out dimensions BEFORE installation begins to confirm tolerances align.

These values are indicative only and may vary depending on the model purchased, installation, and the seasonal resource used to manufacture e-NRG.

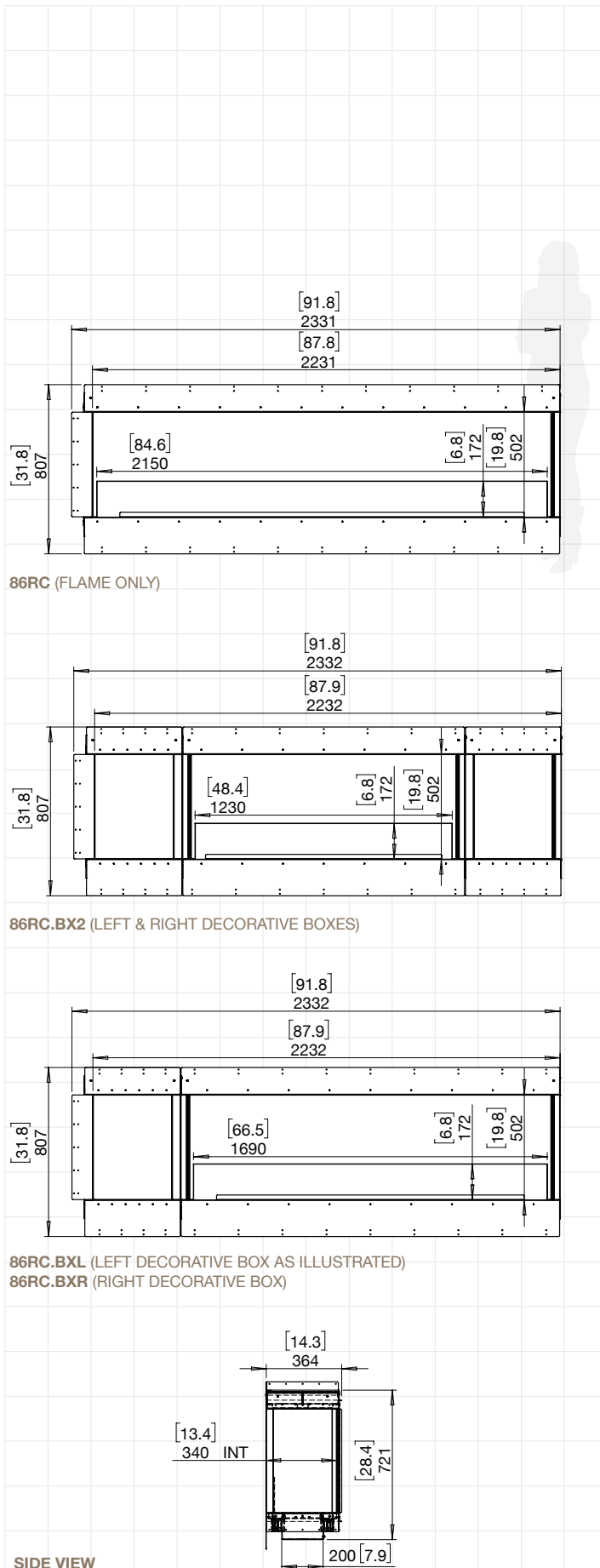

FOR MORE INFORMATION PLEASE REFERENCE THE CLEARANCE & INSTALLATION MANUAL

Disclaimer. All product specifications and data are subject to change without notice and believed to be correct at the time of publication. MAD Design Group (MDG), its affiliates, agents, and employees, and all persons acting on its or their behalf (collectively, "MAD Design Group"), disclaim any and all liability for any errors, inaccuracies or incompleteness contained herein or in any other disclosure relating to any product. MDG disclaims any and all liability arising out of the use or application of any product described herein or of any information provided herein to the maximum extent permitted by law. The product specifications do not expand or otherwise modify MDG's terms and conditions of purchase, including but not limited to the warranty expressed therein, which apply to these products. No license, express or implied, by estoppel or otherwise, to any intellectual property rights is granted by this document or by any conduct of MDG. Customers using or selling MDG products not expressly indicated for use in such applications do so entirely at their own risk and agree to fully indemnify MDG for any damages arising or resulting from such use or sale. Please contact authorised personnel from MDG to obtain written terms and conditions regarding products designed for such applications. Images are indicative only.

LEFT CORNER FIREPLACES

Application	Indoor & Outdoor
Materials	Mild Steel (Zinc Sealed), Toughened Glass, Stainless Steel & Black Glass Charcoal as Decorative Media
Colours	Black Firebox, Stainless Steel Burner/s
Fuel Type	e-NRG Bioethanol

FLEX104

ESF.1.FX.104LC

Weight	149.5kg [328.9lbs] (Incl. burner/s, glass charcoal, glass)
Burner	XL1200 x 2
Volume Capacity	10 Litres [2.6 Gallons] x 2
Heats on Average	Over 130 square metres [1400 square feet]
Burn Time	9 - 14 hours (approx)
Minimum Room Size	230 cubic metres [8122 cubic feet] per fireplace
Minimum Wall Length	2,855mm [112in]

ESF.2.FX.104LC.BX2

Weight	146.9kg [323.2lbs] (Incl. burner/s, glass charcoal, glass)
Burner	XL1200 x 1
Volume Capacity	10 Litres [2.6 Gallons] x 1
Heats on Average	Over 65 square metres [700 square feet]
Burn Time	9 - 14 hours (approx)
Minimum Room Size	115 cubic metres [4061 cubic feet] per fireplace
Minimum Wall Length	2,855mm [112in]

ESF.1.FX.104LC.BXL ESF.1.FX.104LC.BXR

Weight	145.4kg [319.9lbs] (Incl. burner/s, glass charcoal, glass)
Burner	XL900 x 2
Volume Capacity	9 Litres [2.4 Gallons] x 2
Heats on Average	Over 120 square metres [1290 square feet]
Burn Time	8 - 13 hours (approx)
Minimum Room Size	220 cubic metres [7768 cubic feet] per fireplace
Minimum Wall Length	2,855mm [112in]

Physical model dimensions should be verified against cut out dimensions BEFORE installation begins to confirm tolerances align.

These values are indicative only and may vary depending on the model purchased, installation, and the seasonal resource used to manufacture e-NRG.

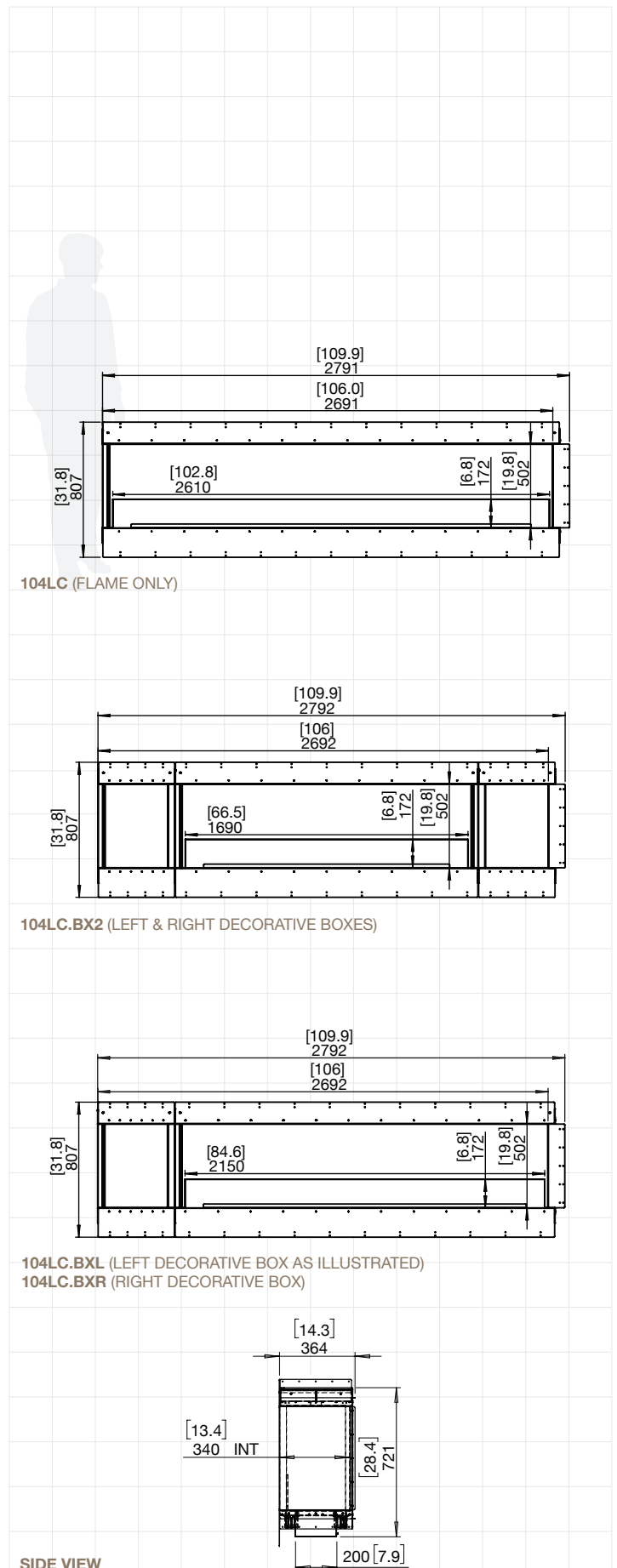

FOR MORE INFORMATION PLEASE REFERENCE THE CLEARANCE & INSTALLATION MANUAL

Disclaimer: All product specifications and data are subject to change without notice and believed to be correct at the time of publication. MAD Design Group (MDG), its affiliates, agents, and employees, and all persons acting on its or their behalf (collectively, "MAD Design Group"), disclaim any and all liability for any errors, inaccuracies or incompleteness contained herein or in any other disclosure relating to any product. MDG disclaims any and all liability arising out of the use or application of any product described herein or of any information provided herein to the maximum extent permitted by law. The product specifications do not expand or otherwise modify MDG's terms and conditions of purchase, including but not limited to the warranty expressed therein, which apply to these products. No license, express or implied, by estoppel or otherwise, to any intellectual property rights is granted by this document or by any conduct of MDG. Customers using or selling MDG products not expressly indicated for use in such applications do so entirely at their own risk and agree to fully indemnify MDG for any damages arising or resulting from such use or sale. Please contact authorized personnel from MDG to obtain written terms and conditions regarding products designed for such applications. Images are indicative only.

Right Corner Fireplaces

Award	2020 BIMsmith Best Award (USA)
Application	Indoor & Outdoor
Materials	Mild Steel (Zinc Sealed), Toughened Glass, Grade 304 Stainless Steel
Colours	Black Firebox, Stainless Steel Burner/s
Fuel Type	e-NRG Bioethanol

FLEX104

ESF.1.FX.104RC

Weight	149.5kg [328.9lbs] (Incl. burner/s, glass charcoal, glass)
Burner	XL1200 x 2
Volume Capacity	10 Litres [2.6 Gallons] x 2
Heats on Average	Over 130 square metres [1400 square feet]
Burn Time	9 - 14 hours (approx)
Minimum Room Size	230 cubic metres [8122 cubic feet] per fireplace
Minimum Wall Length	2,855mm [112in]

ESF.2.FX.104RC.BX2

Weight	146.9kg [323.2lbs] (Incl. burner/s, glass charcoal, glass)
Burner	XL1200 x 1
Volume Capacity	10 Litres [2.6 Gallons] x 1
Heats on Average	Over 65 square metres [700 square feet]
Burn Time	9 - 14 hours (approx)
Minimum Room Size	115 cubic metres [4061 cubic feet] per fireplace
Minimum Wall Length	2,855mm [112in]

ESF.1.FX.104RC.BXL ESF.1.FX.104RC.BXR

Weight	145.4kg [319.9lbs] (Incl. burner/s, glass charcoal, glass)
Burner	XL900 x 2
Volume Capacity	9 Litres [2.4 Gallons] x 2
Heats on Average	Over 120 square metres [1290 square feet]
Burn Time	8 - 13 hours (approx)
Minimum Room Size	220 cubic metres [7768 cubic feet] per fireplace
Minimum Wall Length	2,855mm [112in]

Physical model dimensions should be verified against cut out dimensions BEFORE installation begins to confirm tolerances align.

These values are indicative only and may vary depending on the model purchased, installation, and the seasonal resource used to manufacture e-NRG.

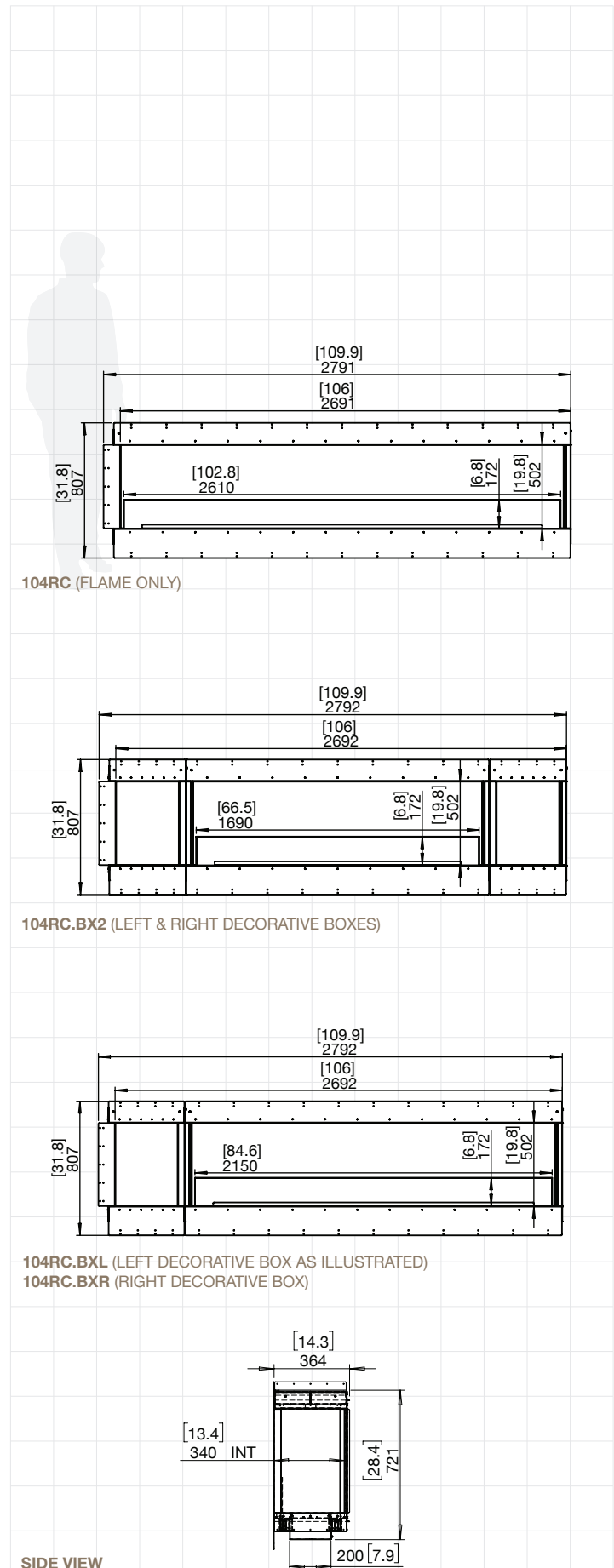

FOR MORE INFORMATION PLEASE REFERENCE THE CLEARANCE & INSTALLATION MANUAL

Disclaimer. All product specifications and data are subject to change without notice and believed to be correct at the time of publication. MAD Design Group (MDG), its affiliates, agents, and employees, and all persons acting on its or their behalf (collectively, "MAD Design Group"), disclaim any and all liability for any errors, inaccuracies or incompleteness contained herein or in any other disclosure relating to any product. MDG disclaims any and all liability arising out of the use or application of any product described herein or of any information provided herein to the maximum extent permitted by law. The product specifications do not expand or otherwise modify MDG's terms and conditions of purchase, including but not limited to the warranty expressed therein, which apply to these products. No license, express or implied, by estoppel or otherwise, to any intellectual property rights is granted by this document or by any conduct of MDG. Customers using or selling MDG products not expressly indicated for use in such applications do so entirely at their own risk and agree to fully indemnify MDG for any damages arising or resulting from such use or sale. Please contact authorised personnel from MDG to obtain written terms and conditions regarding products designed for such applications. Images are indicative only.

LEFT CORNER FIREPLACES

Application	Indoor & Outdoor
Materials	Mild Steel (Zinc Sealed), Toughened Glass, Stainless Steel & Black Glass Charcoal as Decorative Media
Colours	Black Firebox, Stainless Steel Burner/s
Fuel Type	e-NRG Bioethanol

FLEX122

ESF.1.FX.122LC

Weight	171.7kg [377.7lbs] (Incl. burner/s, glass charcoal, glass)
Burner	XL900 x 3
Volume Capacity	9 Litres [2.4 Gallons] x 3
Heats on Average	Over 180 square metres [1935 square feet]
Burn Time	8 - 13 hours (approx)
Minimum Room Size	330 cubic metres [11652 cubic feet] per fireplace
Minimum Wall Length	3,315mm [131in]

ESF.1.FX.122LC.BX2

Weight	169.1kg [372lbs] (Incl. burner/s, glass charcoal, glass)
Burner	XL900 x 2
Volume Capacity	9 Litres [2.4 Gallons] x 2
Heats on Average	Over 120 square metres [1290 square feet]
Burn Time	8 - 13 hours (approx)
Minimum Room Size	220 cubic metres [7768 cubic feet] per fireplace
Minimum Wall Length	3,315mm [131in]

ESF.1.FX.122LC.BXL

ESF.1.FX.122LC.BXR

Weight	173.4kg [381.5lbs] (Incl. burner/s, glass charcoal, glass)
Burner	XL1200 x 2
Volume Capacity	10 Litres [2.6 Gallons] x 2
Heats on Average	Over 130 square metres [1400 square feet]
Burn Time	9 - 14 hours (approx)
Minimum Room Size	230 cubic metres [8122 cubic feet] per fireplace
Minimum Wall Length	3,315mm [131in]

Physical model dimensions should be verified against cut out dimensions BEFORE installation begins to confirm tolerances align.

These values are indicative only and may vary depending on the model purchased, installation, and the seasonal resource used to manufacture e-NRG.

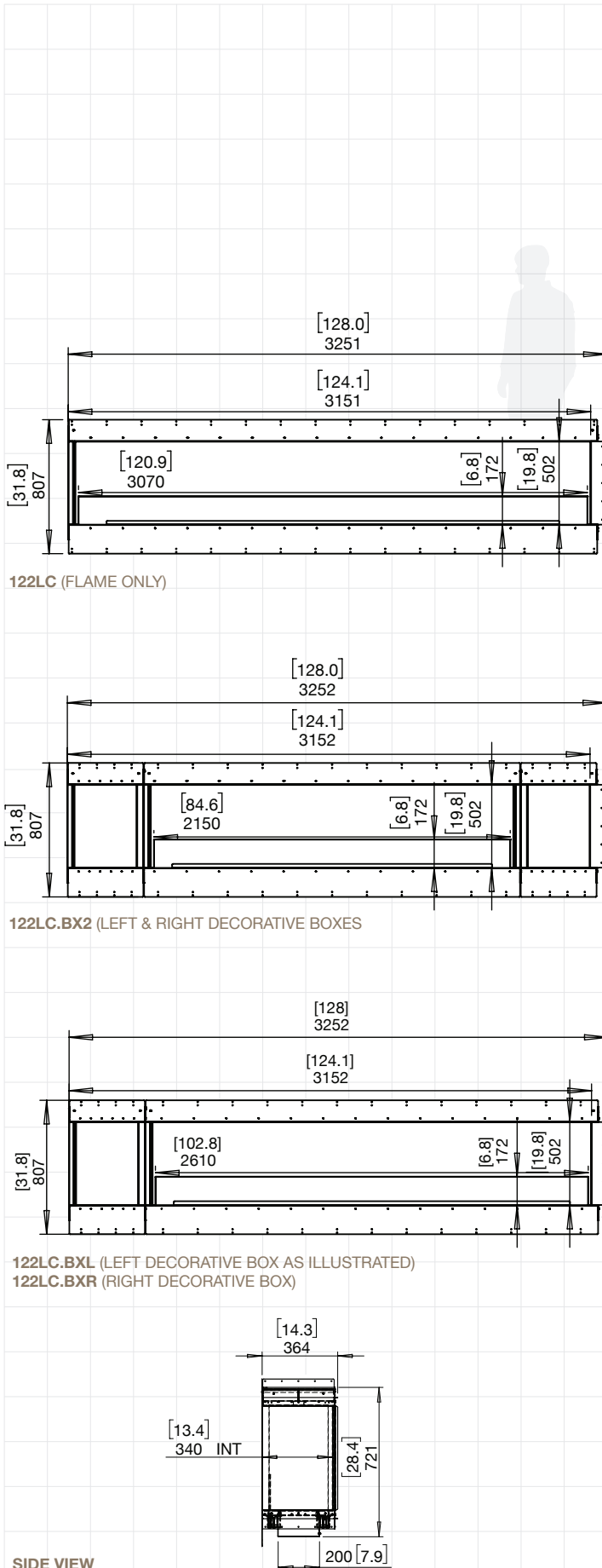

FOR MORE INFORMATION PLEASE REFERENCE THE CLEARANCE & INSTALLATION MANUAL

Disclaimer: All product specifications and data are subject to change without notice and believed to be correct at the time of publication. MAD Design Group (MDG), its affiliates, agents, and employees, and all persons acting on its or their behalf (collectively, "MAD Design Group"), disclaim any and all liability for any errors, inaccuracies or incompleteness contained herein or in any other disclosure relating to any product. MDG disclaims any and all liability arising out of the use or application of any product described herein or of any information provided herein to the maximum extent permitted by law. The product specifications do not expand or otherwise modify MDG's terms and conditions of purchase, including but not limited to the warranty expressed therein, which apply to these products. No license, express or implied, by estoppel or otherwise, to any intellectual property rights is granted by this document or by any conduct of MDG. Customers using or selling MDG products not expressly indicated for use in such applications do so entirely at their own risk and agree to fully indemnify MDG for any damages arising or resulting from such use or sale. Please contact authorised personnel from MDG to obtain written terms and conditions regarding products designed for such applications. Images are indicative only.

RIGHT CORNER FIREPLACES

Application	Indoor & Outdoor
Materials	Mild Steel (Zinc Sealed), Toughened Glass, Stainless Steel & Black Glass Charcoal as Decorative Media
Colours	Black Firebox, Stainless Steel Burner/s
Fuel Type	e-NRG Bioethanol

FLEX122

ESF.1.FX.122RC

Weight	171.7kg [377.7lbs] (Incl. burner/s, glass charcoal, glass)
Burner	XL900 x 3
Volume Capacity	9 Litres [2.4 Gallons] x 3
Heats on Average	Over 180 square metres [1935 square feet]
Burn Time	8 - 13 hours (approx)
Minimum Room Size	330 cubic metres [11652 cubic feet] per fireplace
Minimum Wall Length	3,315mm [131in]

ESF.1.FX.122RC.BX2

Weight	169.1kg [372lbs] (Incl. burner/s, glass charcoal, glass)
Burner	XL900 x 2
Volume Capacity	9 Litres [2.4 Gallons] x 2
Heats on Average	Over 120 square metres [1290 square feet]
Burn Time	8 - 13 hours (approx)
Minimum Room Size	220 cubic metres [7768 cubic feet] per fireplace
Minimum Wall Length	3,315mm [131in]

ESF.1.FX.122RC.BXL ESF.1.FX.122RC.BXR

Weight	173.4kg [381.5lbs] (Incl. burner/s, glass charcoal, glass)
Burner	XL1200 x 2
Volume Capacity	10 Litres [2.6 Gallons] x 2
Heats on Average	Over 130 square metres [1400 square feet]
Burn Time	9 - 14 hours (approx)
Minimum Room Size	230 cubic metres [8122 cubic feet] per fireplace
Minimum Wall Length	3,315mm [131in]

Physical model dimensions should be verified against cut out dimensions BEFORE installation begins to confirm tolerances align.

These values are indicative only and may vary depending on the model purchased, installation, and the seasonal resource used to manufacture e-NRG.

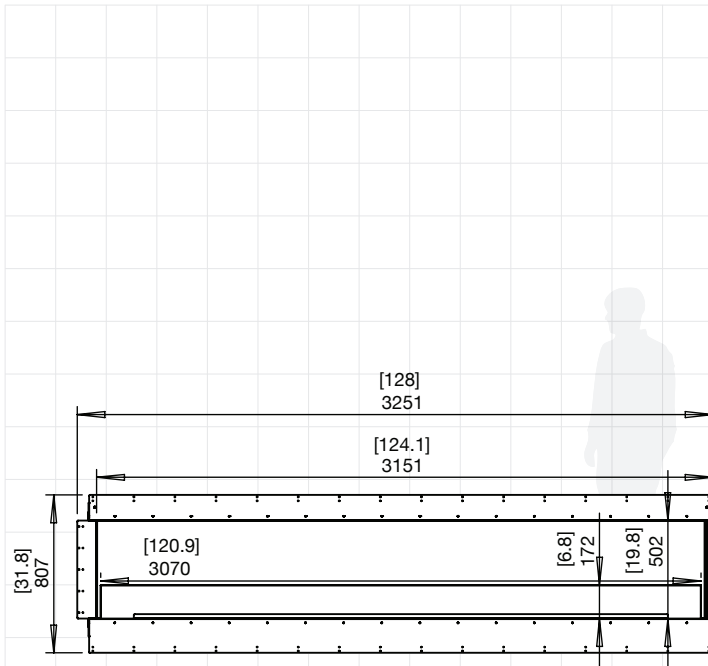

122RC (FLAME ONLY)

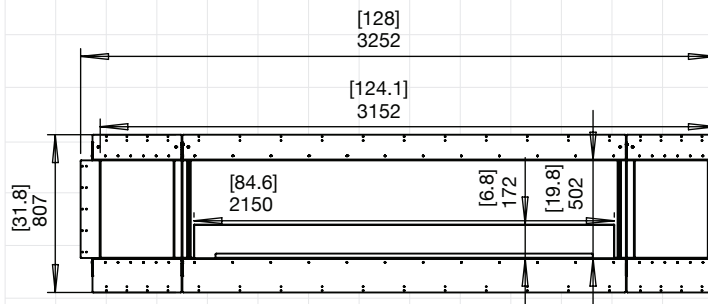

122RC.BX2 (LEFT & RIGHT DECORATIVE BOXES)

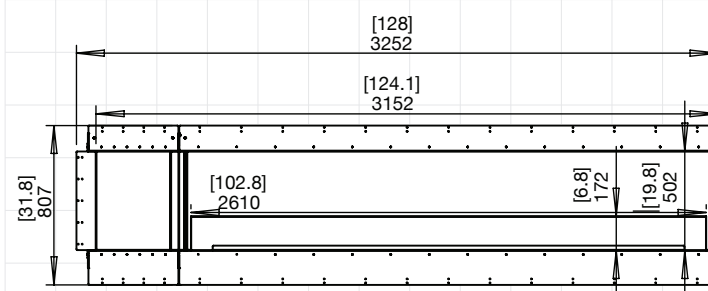

122RC.BXL (LEFT DECORATIVE BOX AS ILLUSTRATED)
122RC.BXR (RIGHT DECORATIVE BOX)

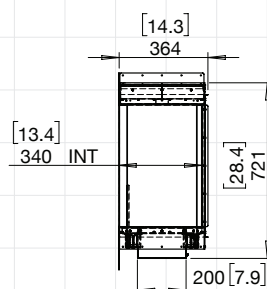

SIDE VIEW

FOR MORE INFORMATION PLEASE REFERENCE THE CLEARANCE & INSTALLATION MANUAL

Disclaimer: All product specifications and data are subject to change without notice and believed to be correct at the time of publication. MAD Design Group (MDG), its affiliates, agents, and employees, and all persons acting on its or their behalf (collectively, "MAD Design Group"), disclaim any and all liability for any errors, inaccuracies or incompleteness contained herein or in any other disclosure relating to any product. MDG disclaims any and all liability arising out of the use or application of any product described herein or of any information provided herein to the maximum extent permitted by law. The product specifications do not expand or otherwise modify MDG's terms and conditions of purchase, including but not limited to the warranty expressed therein, which apply to these products. No license, express or implied, by estoppel or otherwise, to any intellectual property rights is granted by this document or by any conduct of MDG. Customers using or selling MDG products not expressly indicated for use in such applications do so entirely at their own risk and agree to fully indemnify MDG for any damages arising or resulting from such use or sale. Please contact authorized personnel from MDG to obtain written terms and conditions regarding products designed for such applications. Images are indicative only.

Left Corner Fireplaces

Award	2020 BIMsmith Best Award (USA)
Application	Indoor & Outdoor
Materials	Mild Steel (Zinc Sealed), Toughened Glass, Grade 304 Stainless Steel
Colours	Black Firebox, Stainless Steel Burner/s
Fuel Type	e-NRG Bioethanol

FLEX158

ESF.1.FX.158LC

Weight	225.5kg [496.1lbs] (incl. burner/s, glass charcoal, glass)
Burner	XL1200 x 3
Volume Capacity	10 Litres [2.6 Gallons] x 3
Heats on Average	Over 195 square metres [2100 square feet]
Burn Time	9 - 14 hours (approx)
Minimum Room Size	345 cubic metres [12183 cubic feet] per fireplace
Minimum Wall Length	4,235mm [167in]

ESF.1.FX.158LC.BX2

Weight	219.1kg [482lbs] (incl. burner/s, glass charcoal, glass)
Burner	XL900 x 3
Volume Capacity	9 Litres [2.4 Gallons] x 3
Heats on Average	Over 180 square metres [1935 square feet]
Burn Time	8 - 13 hours (approx)
Minimum Room Size	330 cubic metres [11652 cubic feet] per fireplace
Minimum Wall Length	4,235mm [167in]

Physical model dimensions should be verified against cut out dimensions BEFORE installation begins to confirm tolerances align.

These values are indicative only and may vary depending on the model purchased, installation, and the seasonal resource used to manufacture e-NRG.

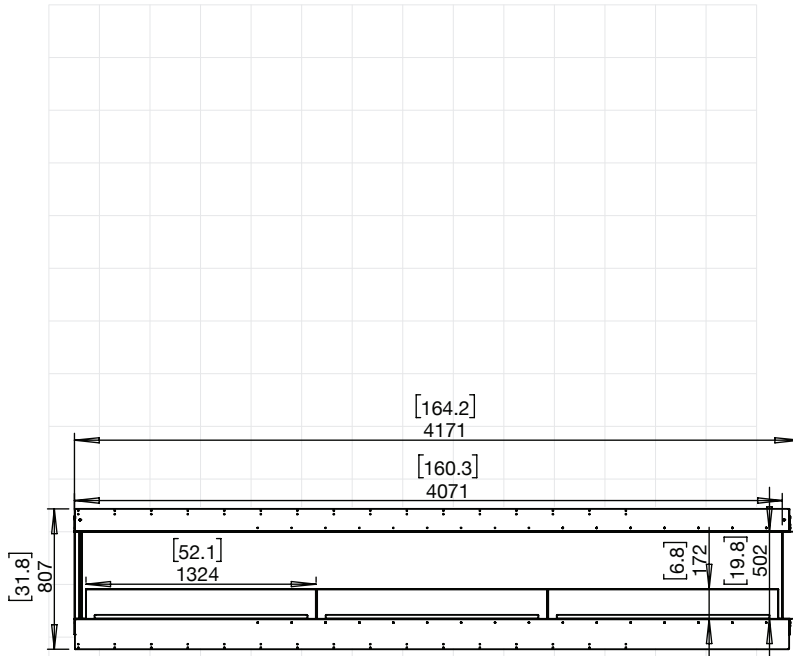

158LC (FLAME ONLY)

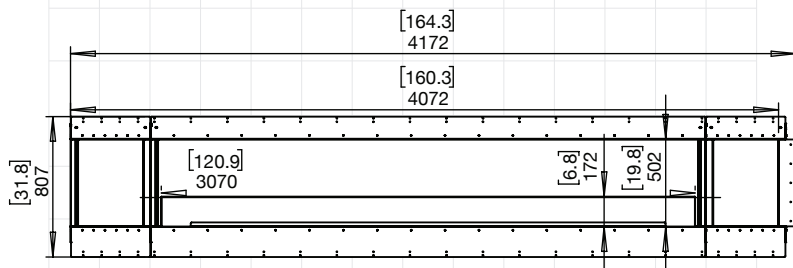

158LC.BX2 (LEFT & RIGHT DECORATIVE BOXES)

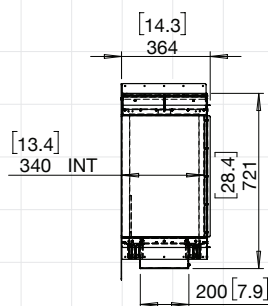

SIDE VIEW

FOR MORE INFORMATION PLEASE REFERENCE THE CLEARANCE & INSTALLATION MANUAL

Disclaimer: All product specifications and data are subject to change without notice and believed to be correct at the time of publication. MAD Design Group (MDG), its affiliates, agents, and employees, and all persons acting on its or their behalf (collectively, "MAD Design Group"), disclaim any and all liability for any errors, inaccuracies or incompleteness contained herein or in any other disclosure relating to any product. MDG disclaims any and all liability arising out of the use or application of any product described herein or of any information provided herein to the maximum extent permitted by law. The product specifications do not expand or otherwise modify MDG's terms and conditions of purchase, including but not limited to the warranty expressed therein, which apply to these products. No license, express or implied, by estoppel or otherwise, to any intellectual property rights is granted by this document or by any conduct of MDG. Customers using or selling MDG products not expressly indicated for use in such applications do so entirely at their own risk and agree to fully indemnify MDG for any damages arising or resulting from such use or sale. Please contact authorised personnel from MDG to obtain written terms and conditions regarding products designed for such applications. Images are indicative only.

Right Corner Fireplaces

Award	2020 BIMsmith Best Award (USA)
Application	Indoor & Outdoor
Materials	Mild Steel (Zinc Sealed), Toughened Glass, Grade 304 Stainless Steel
Colours	Black Firebox, Stainless Steel Burner/s
Fuel Type	e-NRG Bioethanol

FLEX158

ESF.1.FX.158RC

Weight	225.5kg [496.1lbs] (Incl. burner/s, glass charcoal, glass)
Burner	XL1200 x 3
Volume Capacity	10 Litres [2.6 Gallons] x 3
Heats on Average	Over 195 square metres [2100 square feet]
Burn Time	9 - 14 hours (approx)
Minimum Room Size	345 cubic metres [12183 cubic feet] per fireplace
Minimum Wall Length	4,235mm [167in]

ESF.1.FX.158RC.BX2

Weight	219.1kg [482lbs] (Incl. burner/s, glass charcoal, glass)
Burner	XL900 x 3
Volume Capacity	9 Litres [2.4 Gallons] x 3
Heats on Average	Over 180 square metres [1935 square feet]
Burn Time	8 - 13 hours (approx)
Minimum Room Size	330 cubic metres [11652 cubic feet] per fireplace
Minimum Wall Length	4,235mm [167in]

Physical model dimensions should be verified against cut out dimensions BEFORE installation begins to confirm tolerances align.

These values are indicative only and may vary depending on the model purchased, installation, and the seasonal resource used to manufacture e-NRG.

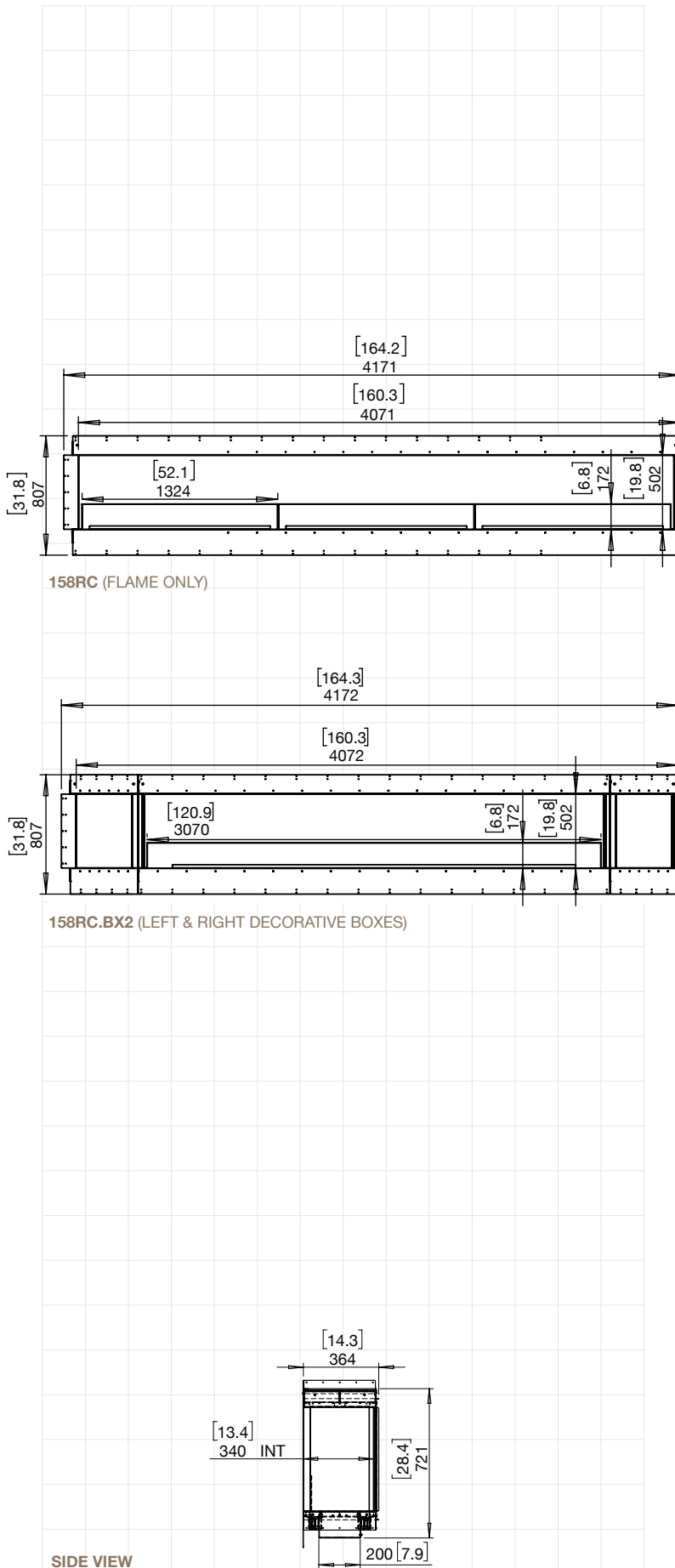

FOR MORE INFORMATION PLEASE REFERENCE THE CLEARANCE & INSTALLATION MANUAL

Disclaimer: All product specifications and data are subject to change without notice and believed to be correct at the time of publication. MAD Design Group (MDG), its affiliates, agents, and employees, and all persons acting on its or their behalf (collectively, "MAD Design Group"), disclaim any and all liability for any errors, inaccuracies or incompleteness contained herein or in any other disclosure relating to any product. MDG disclaims any and all liability arising out of the use or application of any product described herein to the maximum extent permitted by law. The product specifications do not expand or otherwise modify MDG's terms and conditions of purchase, including but not limited to the warranty expressed therein, which apply to these products. No license, express or implied, by estoppel or otherwise, to any intellectual property rights is granted by this document or by any conduct of MDG. Customers using or selling MDG products not expressly indicated for use in such applications do so entirely at their own risk and agree to fully indemnify MDG for any damages arising or resulting from such use or sale. Please contact authorised personnel from MDG to obtain written terms and conditions regarding products designed for such applications. Images are indicative only.