

Cobber CB039 Thermostatic Mixer with Three-Way Diverter

hotbath
italian bathroomware



FINISHES

- Chrome **CB039EXT.CR.US**
- Brushed Nickel **CB039EXT.GN.US**
- Matte Black **CB039EXT.BL.US**
- Matte White* **CB039EXT.WH.US**
- Aged Iron* **CB039EXT.AI.US**
- Black Chrome* **CB039EXT.BK.US**
- Living Brushed Brass* **CB039EXT.BB.US**
- Living Natural Brass* **CB039EXT.NB.US**
- PVD Brushed Brass* **CB039EXT.BBP.US**
- PVD Brushed Copper* **CB039EXT.BCP.US**

*Indicated finishes are not cUPC listed and may not meet standards listed below.

MATERIAL:	solid brass
FEATURES:	> thermostatic mixer > three-way diverter
REQUIRED ROUGH VALVE:	HB039.US
NET WEIGHT:	2 lbs
PACKAGE DIMENSIONS:	L 10" x W 9" x H 4"
DELIVERY WEIGHT:	3 lbs
WARRANTY:	2-year limited warranty
MAINTENANCE & CARE:	Visit watrline.com/hotbath-care for more information

PRODUCT MEETS OR EXCEEDS: > ASME A112.18.1/CSA B125.1

Specifications and dimensions may contain errors and are subject to change without notice.

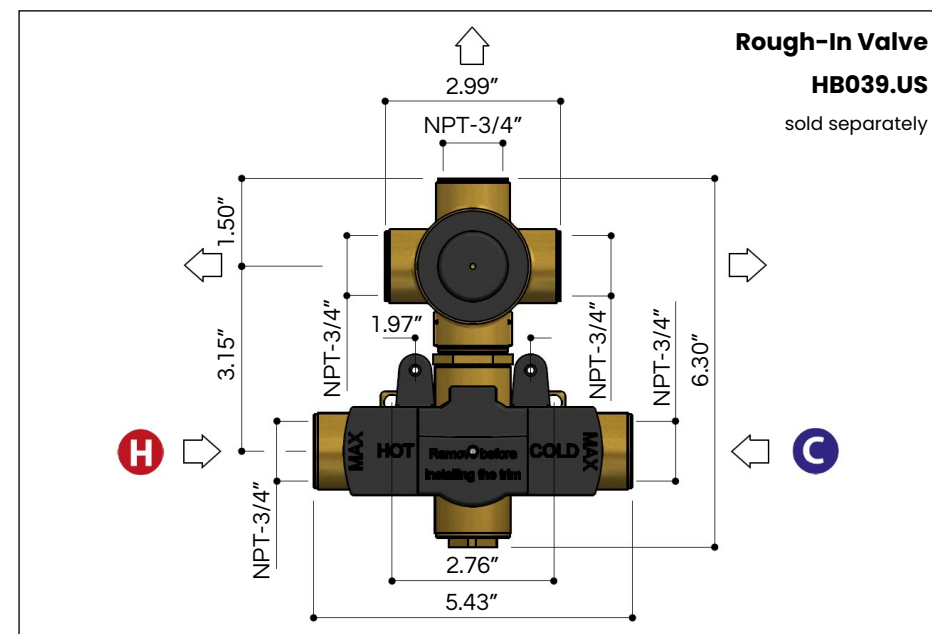
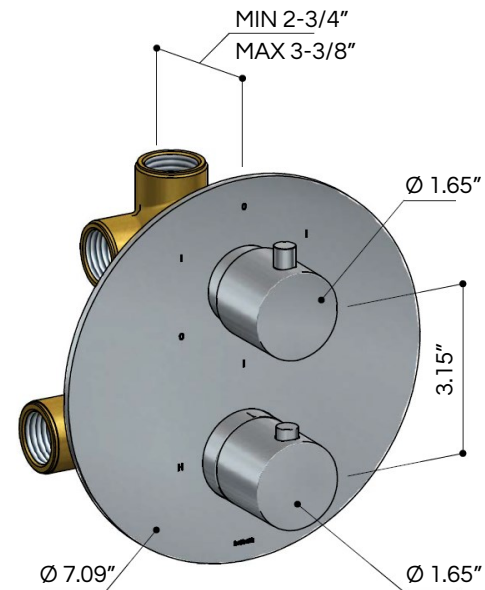

Rough-In Valve

HB039.US

sold separately