

# CHARGING CABINET MODULAR ASSEMBLY INSTRUCTIONS

## ACC-STK CHG CAB X6SC USBC

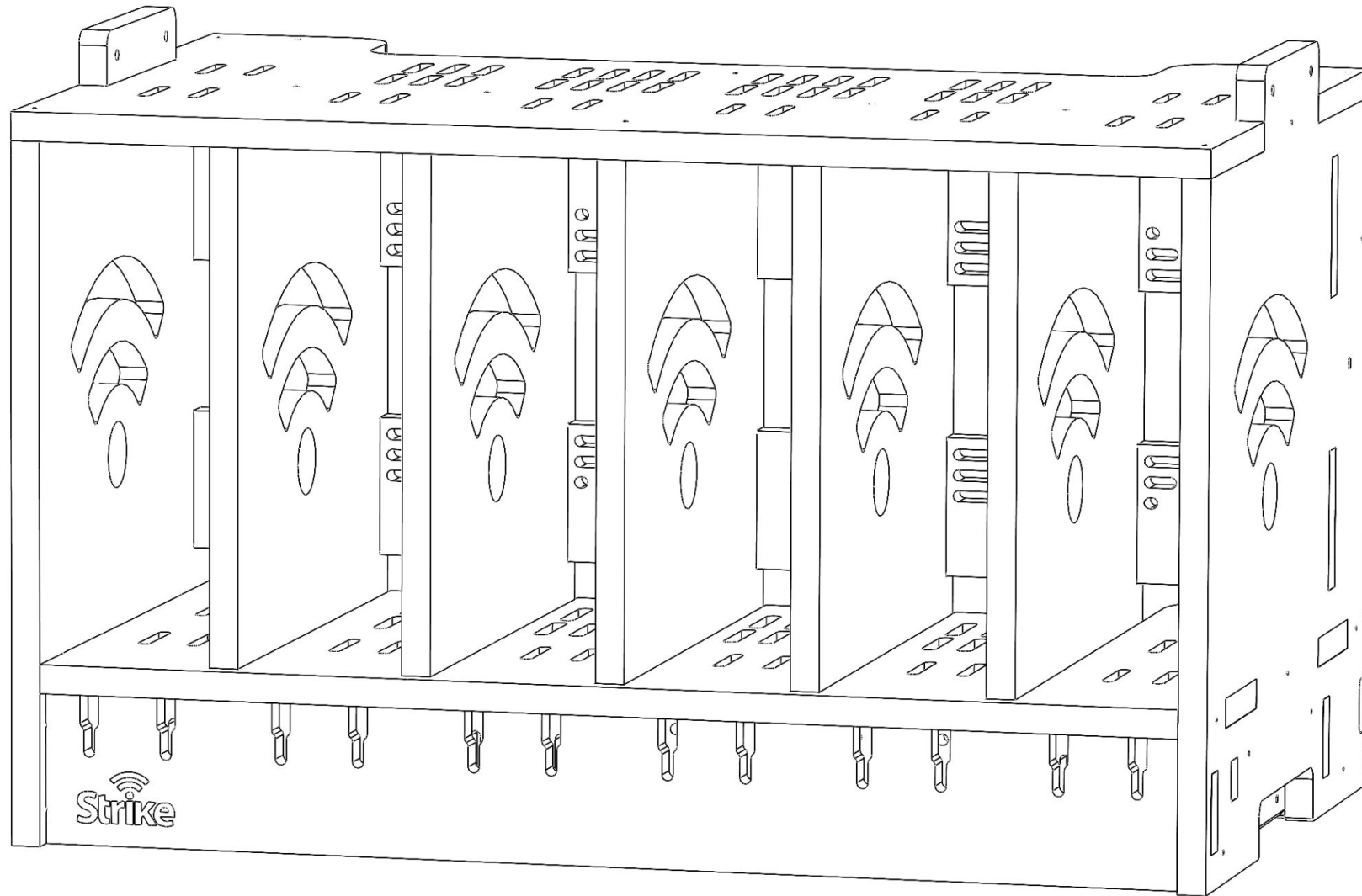

# PARTS LIST

## CHARGING CABINET

Charging Cabinet

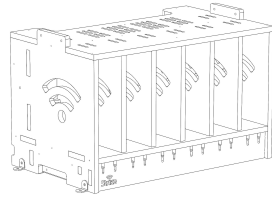

x 1

Power Lead -  
USB-A  
Charger

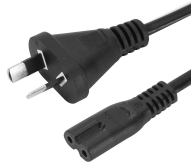

x 1

## WALL/SHELF HARDWARE

Right Angle Bracket



x 4

16mm CSK screw



x 8

## STACKING HARDWARE

20mm CSK screw



x 4

## JOINING HARDWARE

20mm Barrel Nut



x 1

6mm Hex Bolt



x 1

# POWER

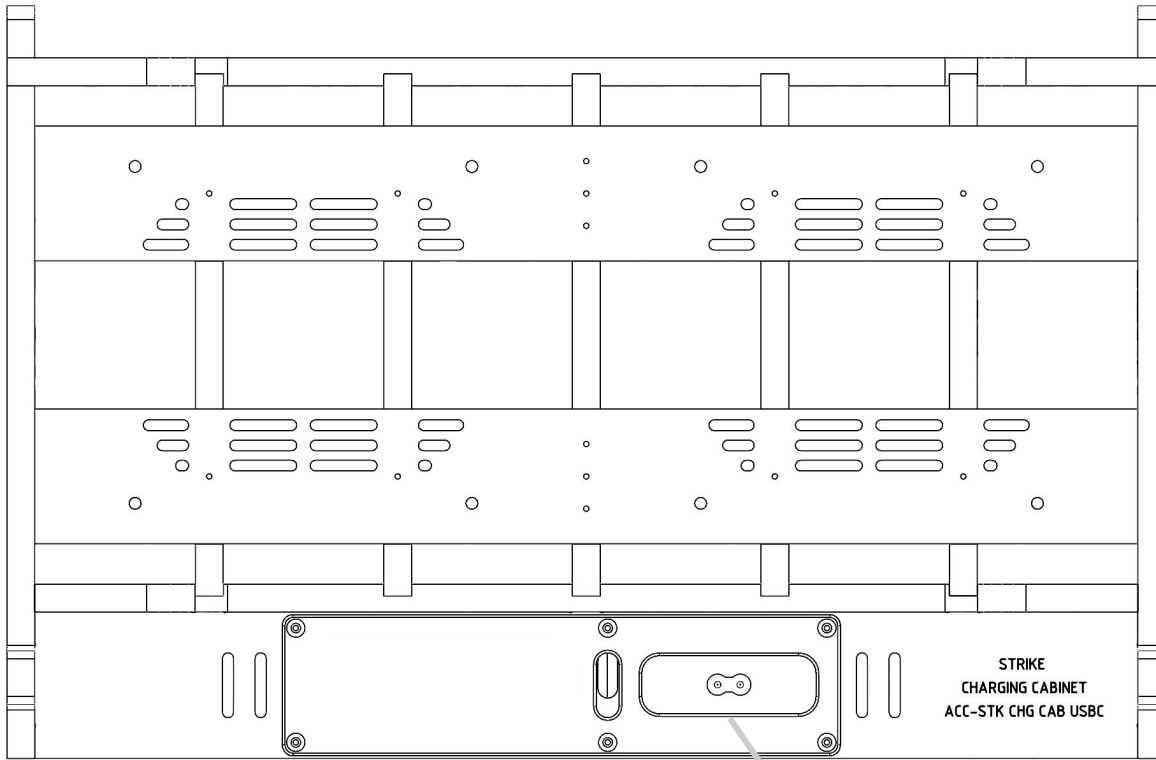

**Charging Cabinet**

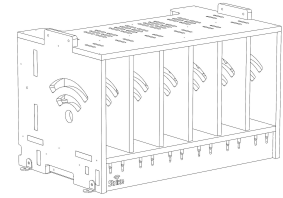

**x 1**

**Power Lead -  
USB-A  
Charger**



**x 1**

## SECURING TO SHELF

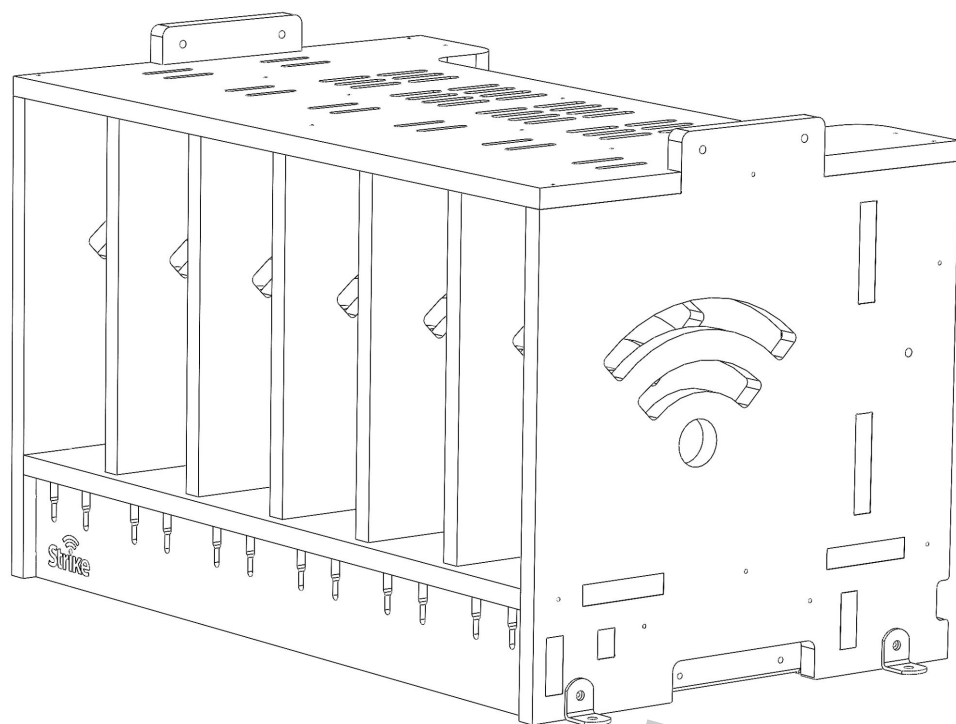

Right Angle  
Bracket



x 4

16mm CSK  
screw



x 8



\* Use appropriate fixings for shelf material (Timber screws provided)

\* Do not overtighten when screwing into cabinet material

## STACKING CABINETS

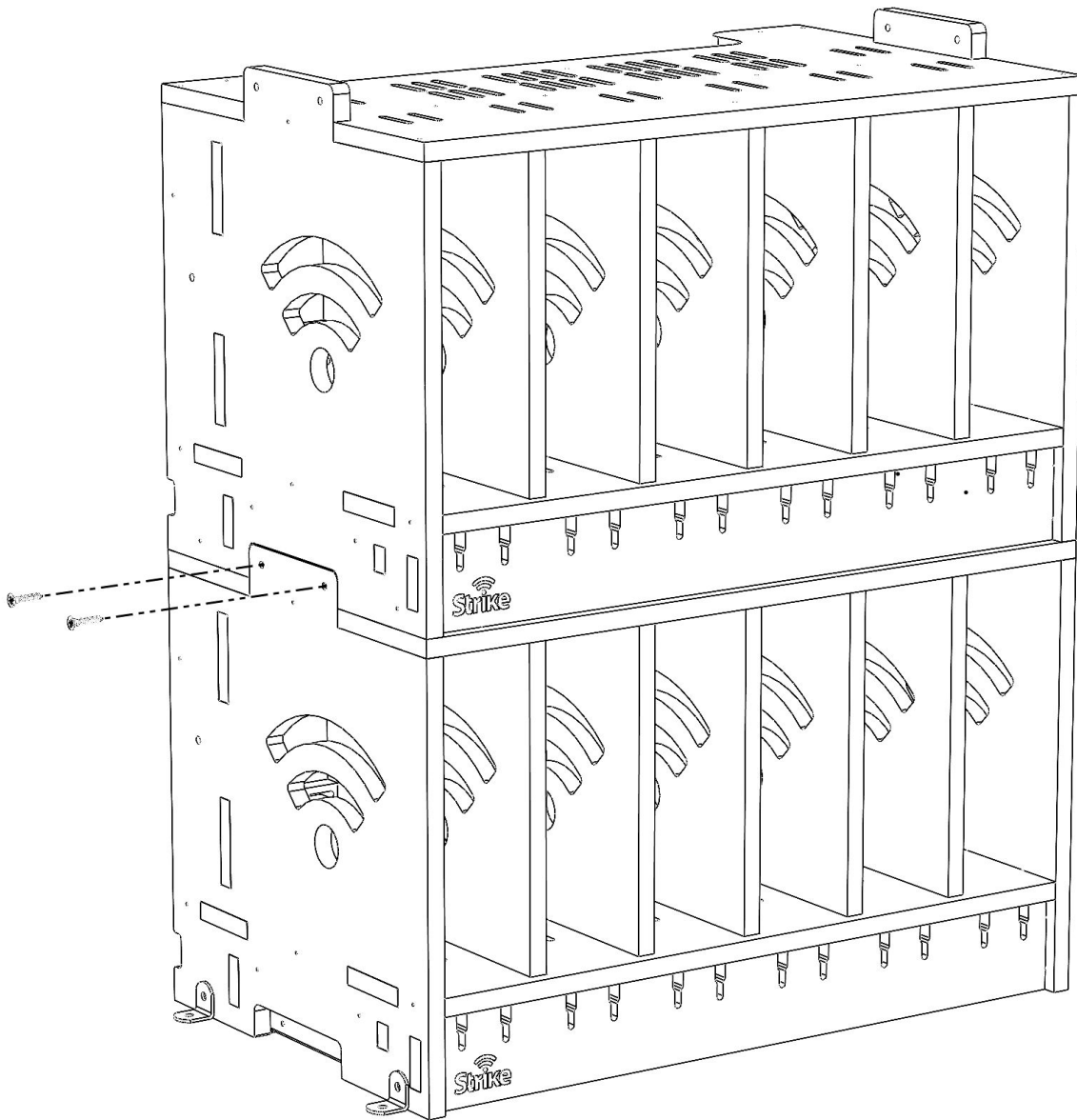

20mm CSK  
screw



x 4



\* Do not overtighten when screwing into cabinet material



## JOINING CABINETS

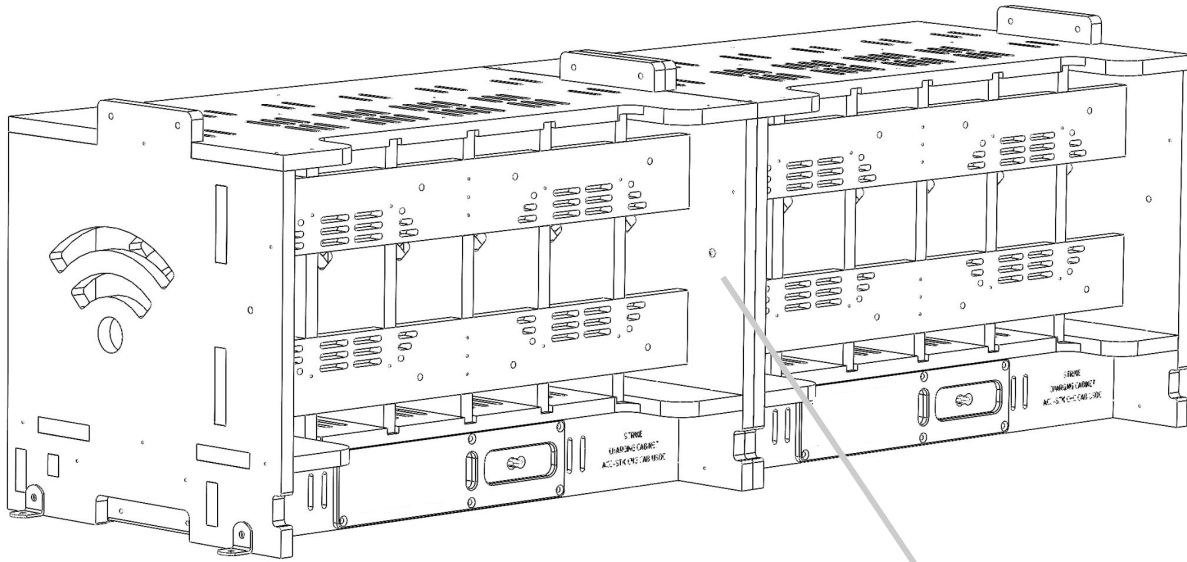

20mm Barrel  
Nut



x 1

6mm Hex  
Bolt



x 1

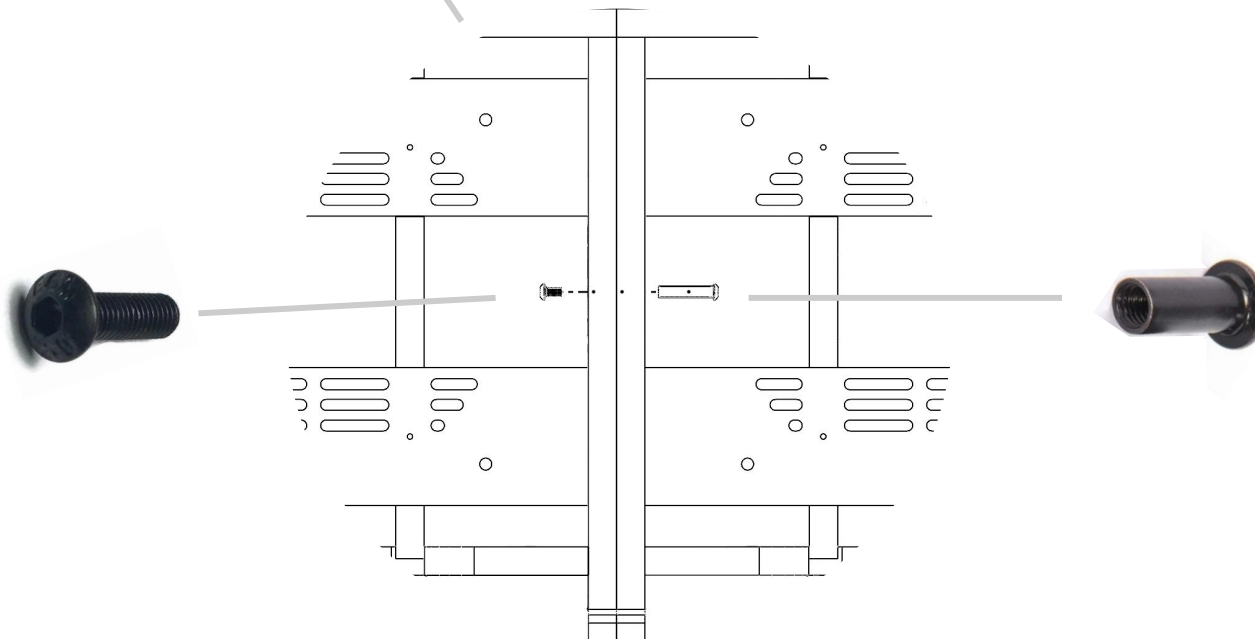

- \* Do not overtighten
- \* Requires Allen key metric sizes 2 and 2.5
- \* Take care when moving the cabinets once joined

## SECURING TO WALL

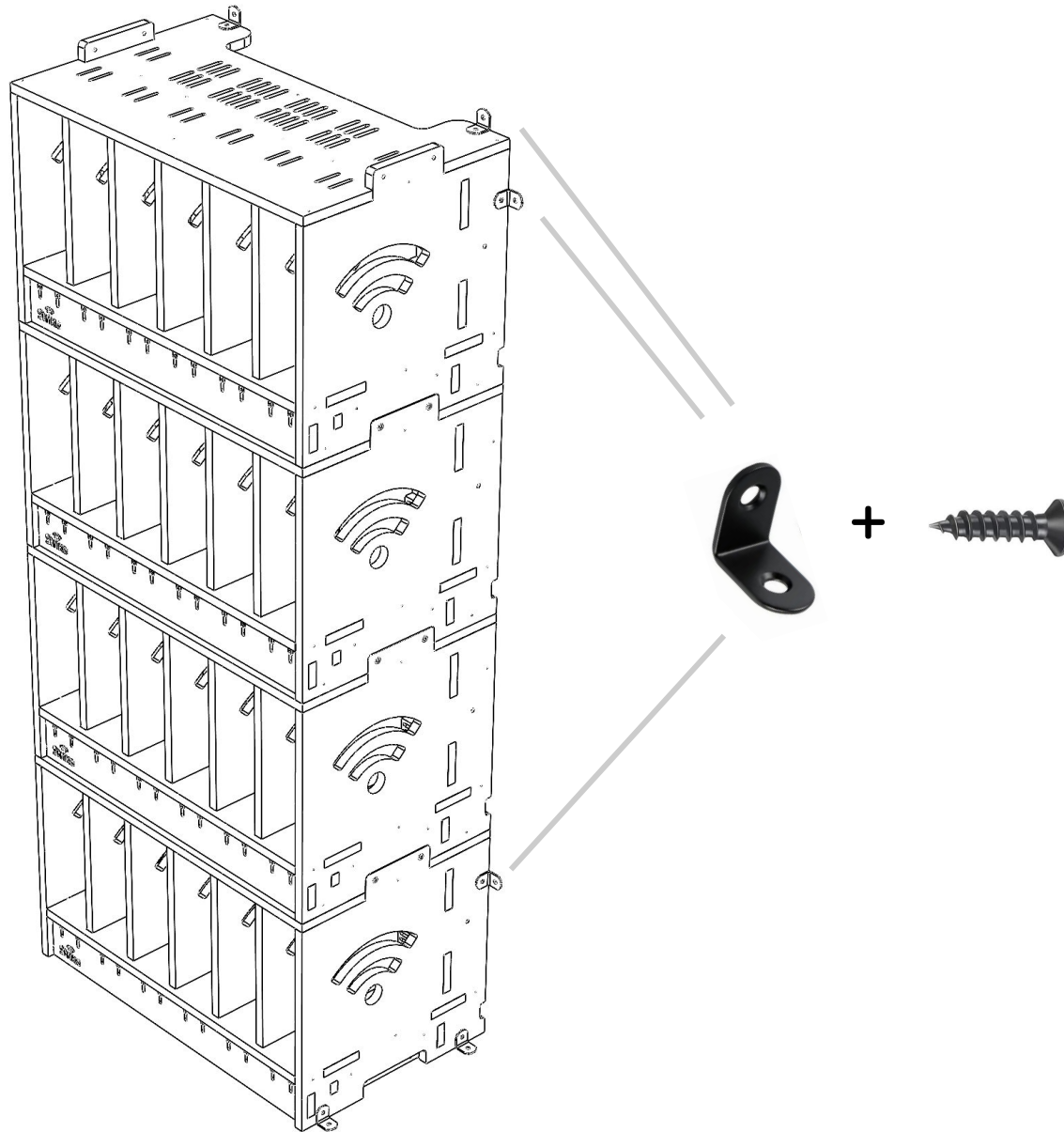

Right Angle  
Bracket



16mm CSK  
screw



- \* Use appropriate fixings for wall material (Timber screws provided)
- \* Do not overtighten when screwing into cabinet material

## MODULAR ASSEMBLY EXAMPLE

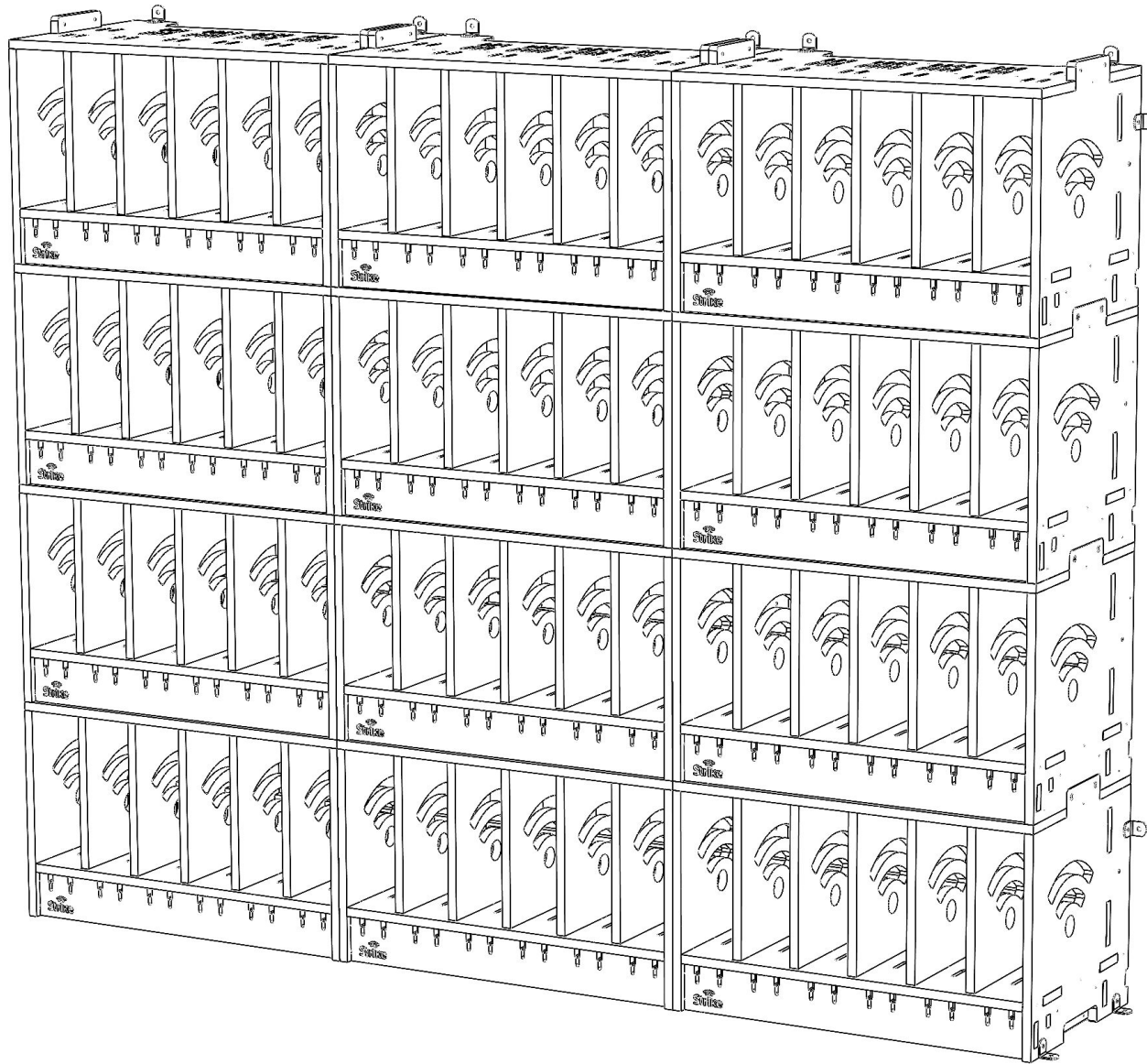

\* Max 4 cabinets high





# SPECIFICATIONS

## DIMENSIONS

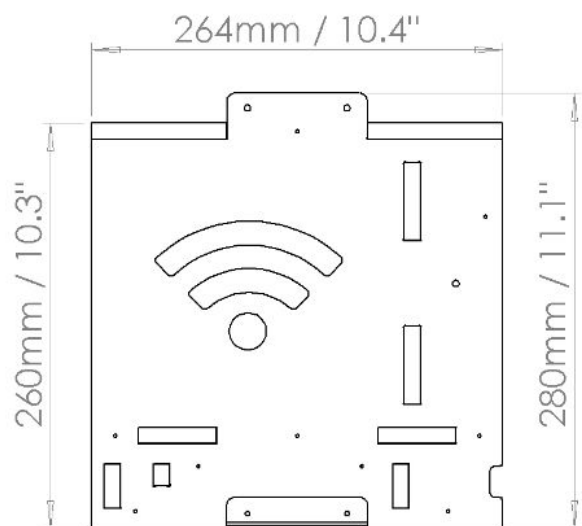
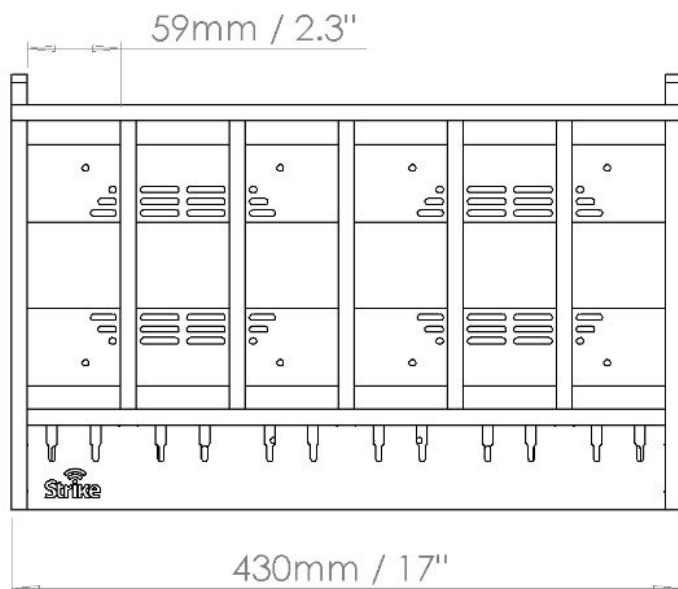

## CHARGING

### 6 x BLACK USB LEADS

TYPE	-	USB-C
PROTOCOL	-	5V (no QC)
POWER	-	6 x 10W* (*Simultaneous charging rates) Or 2.4A per bay max / 12A total max
VOLTAGE	-	5V

