

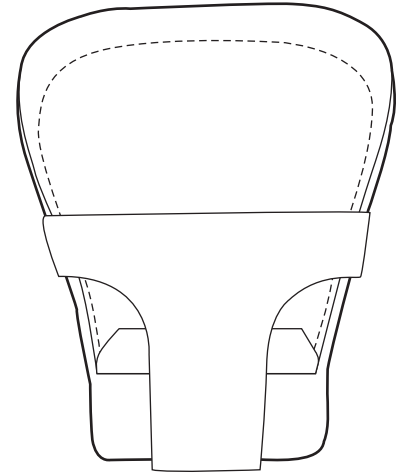

MIMOSA AIRCOOL INFANT INSERT

User Manual



Singapore:

Kim Hin Innovation Labs Private Ltd.
601 Sims Drive, Pan-I Complex
Singapore 387382
Tel: (65) 6831 5020
care.il@kimhinintl.com

Hong Kong:

Trade Solutions Ltd.
Unit D, 13A, Gemstar Tower,
No. 23 Man Lok Street, Hung Hom,
Kowloon, Hong Kong
Tel: (852) 2264 1282

Malaysia:

Global Retail Network Sdn. Bhd. (921399-V)
Wisma Pang Cheng Yeau,
Lot 5205C, Jalan Perindustrian Balakong Jaya 1/3,
Taman Perindustrian Balakong Jaya,
43300 Seri Kembangan,
Selangor Darul Ehsan, Malaysia
Tel: (03) 8940 6638
contactus@globalretail.com.my

MMS18005

 Up to	FROM	3.2kg	7lbs
	TO	6.8kg	15lbs

Compatible with
Mimosa Ergonomic Baby Carrier
Mimosa AirPlush 6-Way Hipseat Baby Carrier
Mimosa AirPlush Ergonomic Baby Carrier

MIMOSA



1. SAFETY INFORMATION 1

2. FEATURES WE LOVE 4

3. INSTRUCTIONS FOR INFANT INSERT & CUSHION..... 5

4. INSTRUCTIONS FOR CUSHION ONLY7

5. CARE INSTRUCTIONS.....8



1. SAFETY INFORMATION

IMPORTANT! Keep instructions for future reference and use.

Warning! Read all instructions for the Mimoso AirCool Infant Insert before assembling and using the infant insert.



FALL HAZARD – INFANT CAN FALL THROUGH OR OUT OF CARRIER AND/OR INFANT INSERT!

- Before each use, make sure all fasteners are secure.
- Take special care when leaning or walking.
- DO NOT USE for babies weighing less than 3.2kg (7 lbs).
- ONLY USE for infants between 3.2kg (7 lbs) and 6.8kg (15 lbs).
- Infants must only be carried in the front inward-facing carry position when using Mimoso AirCool Infant Insert and/or Cushion.
- The Mimoso AirCool Infant Insert is not to be used in any other carry positions.
- Be aware that as the baby becomes more active, the baby has a higher risk of falling out of the carrier and/or infant insert.



SUFFOCATION HAZARD!

- Always allow room for head movement. Your baby should be able to move her/his head without pressing her/his face onto your body. **Babies under 4 months can suffocate in this product if her/his face is pressed tightly against your body.**
- Keep your baby's face free from obstruction at all times.
- Constantly monitor your baby and ensure that the mouth and nose are not blocked. Ensure that her/his airway is clear and breathing is normal at all times.
- There should be a clearance of at least two fingers below your baby's chin. Always check that your baby's chin is not resting on her/his chest as this partially closes the airway. Her/his breathing may become restricted, which could lead to suffocation.
- Premature infants, infants with respiratory problems, and infants under 4 months are at the greatest risk of suffocation.
- Do not use the insert in a lying or reclined position without the carrier.

OTHER WARNINGS

- For premature, low birthweight babies and toddlers with medical conditions, please seek advice from a health professional before using product.
- Allow yourself time to get used to using the carrier as your sense of balance may be affected by the use of a baby carrier. Take special care when bending sideways or leaning forward or backwards.
- Never leave your baby unattended in or with the Mimoso AirCool Infant Insert.
- Practice caution as your baby may insert her/his fingers into buckle openings.
- The infant insert should not be used with athletic activities, eg, running, swimming and cycling.

PRECAUTIONS FOR USE AND INSTRUCTIONS FOR AIRCOOL INFANT INSERT:

- The Mimoso AirCool Infant Insert is designed for use with the Mimoso Ergonomic Baby Carrier, Mimoso AirPlush 6-Way Hipseat Carrier and the Mimoso AirPlush Ergonomic Baby Carrier. For the latest list of compatible carriers, please refer to www.mimoso-online.com.
- Do not use any other infant inserts with Mimoso Carriers as they may be incompatible and may result in injuries.
- The infant insert is designed to help support your baby's head and neck and to help ensure that your baby is sitting correctly in the carrier.
- Use the Mimoso AirCool Infant Insert for babies between 3.2kg (7 lbs) and 6.8kg (15 lbs).



2. FEATURES WE LOVE

- The infant insert should only be used for the **FRONT INWARD-FACING CARRY POSITION**, and no other carry positions.
- Infants more than 15 lbs (6.8 kg) but without strong and consistent head and neck control must continue using the infant insert when using the carrier.
- Use of the infant insert can be discontinued once baby exceeds 6.8kg (15 lbs) AND has developed a robust and consistent control of the head and neck, usually occurring at the mark of 4 months.
- Practice putting on your carrier before using the infant insert with the carrier.
- As your baby grows, their leg positioning will change. The insert supports the thighs in a squat & spread position, with knees at their belly button and legs resting on the sides of the infant insert inside the carrier. As growth progresses, your baby's knees will become higher than the hips along with the legs resting outside of the infant insert and the carrier.
- Your baby's position should be checked regularly to make sure that your baby is properly seated in the infant insert, centered with legs in a squat & spread position, with head upright and not slumping downward or to the side.
- Infant's arms, legs and feet need to be observed regularly while in the carrier to ensure that they are not constricted by the carrier.
- Check for ripped seams, straps or fabric, damaged fasteners and other signs of wear and tear before use. Cease usage if the insert is perceived to be damaged.
- The infant insert should not be used unless and until the user has fully read and understands the instructions and safety features as detailed in this manual.
- Discontinue use of the infant insert for a period of time if the baby shows signs of discomfort while being carried. You can resume when your baby can be carried without exhibiting discomfort.
- **THIS PRODUCT IS NOT A TOY.** Keep the infant insert away from children when it is not in use.
- In very hot climates or during summer, your baby could still become too hot in this product. Please choose the right materials for your baby to wear.
- Our products are handmade and there may be slight variations that do not affect their safety.
- Mimosa uses high quality and safe dyes to ensure that our product will retain its color as much as possible, and are free from harmful chemicals. With printed fabric, the colours will fade slightly with repeated washes, and this will vary by detergent and locale.
- Contact your retailer or Mimosa customer service for additional assistance if needed. For additional information, please visit www.mimosa-online.com.

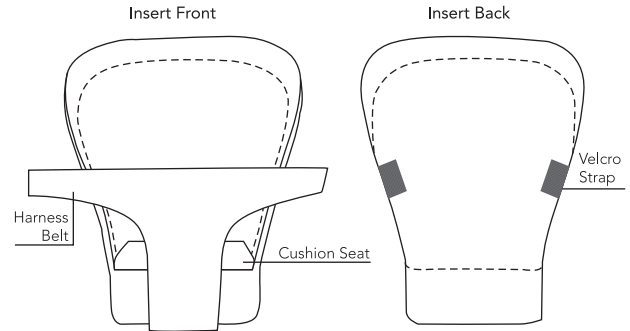





- Helps support proper posturing of your baby in the carrier.
- Shaped to provide cushioned support for your baby's head and neck.
- Cool-touch satin cotton and porous fill for your baby's comfort in warm weather locales.
- Designed for lightness and sleekness for long hours of baby carrying.
- Silky smooth fabric reduces frictional redness.
- Two adjustable velcro straps for universal fit for full-term infants.
- Ultra-soft satin cotton is lush to touch and gently embraces your baby.
- Incorporated harness secures baby in insert.
- Provides an ergonomic M-position seat as your baby grows.
- Cushion elevates the baby and provides better clarity for parents to monitor your baby.
- Removable Cushion can be used separately as a booster seat in the carrier when baby does not yet sit in ergonomic M-position in the carrier.

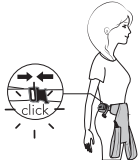

3. INSTRUCTIONS FOR INFANT INSERT & CUSHION

Up to	FROM	3.2kg	7lbs
	TO	6.8kg	15lbs

	<p>a. Fasten your baby carrier around your waist. Allow the carrier panel to hang loose in front of you.</p>
	<p>b. i. Spread infant insert flat on the ground and insert the cushion. ii. Ensure cushion is properly fitted in the insert.</p>
	<p>c. i. Lay your baby facing upwards on the insert, and put your baby's legs through the openings below the harness. ii. Fasten the Velcro on both sides – adjust for a snug fit.</p>
	<p>d. Lift your baby with insert onto the carrier, so that the base of the insert sits on the front lip of your carrier belt, and is in contact with your tummy.</p>

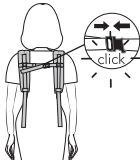
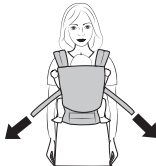
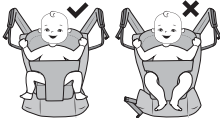

	<p>e. i. Lean your baby with insert towards your chest, supporting them with your stronger hand. Using your free hand, lift the carrier front panel up behind the insert. ii. Using your stronger hand to hold the panel, insert and your baby in place, use your free hand to wear one shoulder strap. Switch hands and repeat.</p>
	<p>f. Buckle the chest strap behind your shoulders to secure your baby in the baby carrier.</p>
	<p>g. Adjust the baby carrier by pulling the adjustable straps under your arms forward so that your baby is comfortable and close to your body.</p>
	<p>h. i. Check that your baby's legs are hanging freely off the opening. ii. Check that your baby's airways are clear.</p>



4. INSTRUCTIONS FOR CUSHION ONLY

Up to 5.5kg
12lbs

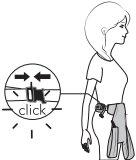
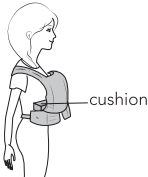
For babies over 5.5kg (12 lbs) with adequate head and neck control, who do not yet sit in m-position in the carrier

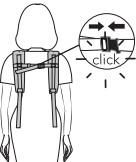
	<p>a. Fasten your baby carrier around your waist. Allow the carrier panel to hang loose in front of you. Insert ONLY the cushion into the carrier.</p>
	<p>b. i. Wear the right strap of the carrier over your right shoulder. The back of the cushion sits on the front lip of your carrier belt, and is in contact with your tummy.</p> <p>ii. Adjust the tightness and height for the right strap of the carrier accordingly.</p>
	<p>c. i. Carry your baby up and place her/him into the cushion.</p> <p>ii. Using one hand to hold the panel, cushion and your baby in place, wear the other strap.</p>
	<p>d. Buckle the chest strap behind your shoulders to secure your baby in the baby carrier.</p>

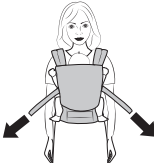
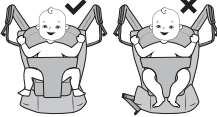
	<p>e. Adjust the baby carrier by pulling the adjustable straps under your arms forward so that your baby is comfortable and close to your body.</p>
	<p>f. i. Check that your baby's legs are hanging freely off the opening.</p> <p>ii. Check that your baby's airways are clear.</p>



5. CARE INSTRUCTIONS



Hand or machine wash in cold water



Do not bleach



Tumble dry low



Do not iron



Do not dry clean