



FermZilla - All-Rounder Instruction Manual (For 30L and 60L AR models)

This instruction sheet contains vital information that is related to the safe usage and handling of the FermZilla All-Rounder. It is vital that you read this instruction sheet from front to back before using the product! THIS IS FOR YOUR OWN SAFETY

Pressure rated and easy to clean, the capable all-rounder.





Contents

WARNINGS	2
What's in the box	3
Step-by-step instructions	4
1. Assembling the fermenter.	4
2. Cleaning and sanitizing the fermenter and equipment	4
Cleaning the FermZilla all-rounder	4
Cleaning the Pressure Relief Valve (PRV).....	5
Cleaning a BlowTie Spunding Valve (If applicable)	5
3. Conducting a Leak/Pressure Test (if fermenting under pressure)	7
1. Pressure decay test	7
2. Bubble Test.....	7
4. Hydro-Test Instructions	9
Suggested Additional Equipment.....	10
Premium Equipment Recommendations.....	11
Support.....	11
Warranty (Australia).....	11

WARNINGS

1. When not under pressure do not expose to liquids above 55°C (131°F). Only clean, wash or sanitise the fermenter with cold water.
2. When under pressure do not expose to any temperatures above 35°C (95°F).
3. Keep the fermenter out of direct sun or heat. Do not expose to UV rays of any sort.
4. If you are using a heat belt to warm the fermenter then only have the heat belt sitting below the liquid level. Do not use an unregulated heat source, only use heat sources which are plugged into a temperature controller.
5. Under no circumstances apply more than 2.5bar (35PSI) to the fermenter tank and do not connect an unregulated pressure source. If you connect external pressure source ensure it has independent PRV pre-set to 35psi or below.
6. A spunding valve set below 35psi must always be connected to the FermZilla when fermenting under pressure or connected to the recipient keg when performing a closed transfer.
7. Do not tamper with the pressure relief valve. Only use the red colored pressure relief valve supplied by KegLand.



8. If a vigorous fermentation is experienced and krausen or wort has contacted the PRV, ensure to remove the PRV and clean it before putting the FermZilla under pressure.
9. If the fermenter is scratched, damaged or has been under any physical duress; do not use the fermenter under pressure.
10. If you use the fermenter under pressure hydro test the fermenter every 24months to ensure it is safe to use.
11. Do not use Sodium Metabisulphite or StellarSoda in the FermZilla. Only use chemical cleaners and sanitizers that are approved by Kegland. These include: a) Super Kill Ethyl Sanitiser Spray (effective for sanitising the exterior of the FermZilla) (KL05371) b) StellarSan (mixed to the correct specification) (KL05357) c) StellarClean (not to be left in the FermZilla for more than 30 minutes) (KL05494) ... Or contact <https://www.kegland.com.au/> for more information regarding other compatible chemical cleaning products.
12. Do not over tighten carbonation caps onto the threads of the lid or collection container, doing so could result in the thread being stripped. We recommend using the plastic carbonation and line cleaning caps (KL10788).
13. Do not over tighten the stainless-steel handles onto the neck of the FermZilla.
14. Avoid lifting the FermZilla while full. If filled with wort avoid moving the FermZilla to prevent sticky wort from preventing the PRV from operating.
15. Always conduct a leak test prior to beginning fermentation.

What's in the box

- 1 x Fermzilla – 30L all-rounder fermenter
- 1 x KL11402 Fermzilla Pressure Capable Lid
 - with 2 x PCO1881 male threads for carbonation / bottle caps
 - 1 x KL05333 Red Pressure Relief Valve (35psi/2.5 Bar)
 - 1 x KL11426 FermZilla Thicker Lid O-Ring (OD 106mm x 2.65mm)
- 1 x KL11396 Fermzilla lid ring
- 1 x KL13079 Stainless Steel Carry Handles
- 1 x KL21579 PET Bottle Cap (e.g. Coca Cola Bottle Cap)
- 1 x KL21586 PET Bottle Cap (With Hole and Grommet)
- 1 x KL01595 3 Piece Airlock

Step-by-step instructions

1. Assembling the fermenter.

Once you have unboxed your KegLand all-rounder and checked everything is included and the tank is undamaged, begin by assembling your fermenter.

FermZilla – Lid Assembly

1. Ensure the lid assembly has the o-ring attached.
2. Apply some food grade lubricant to the o-ring to extend the life of this o-ring and threads.
3. Place the lid onto the neck of the tank and screw down the threaded lid ring hand-tight.
4. Use the two bottle caps to close the two threaded holes in the lid.
5. Push the three-piece air-lock into the remaining (central) hole of the lid

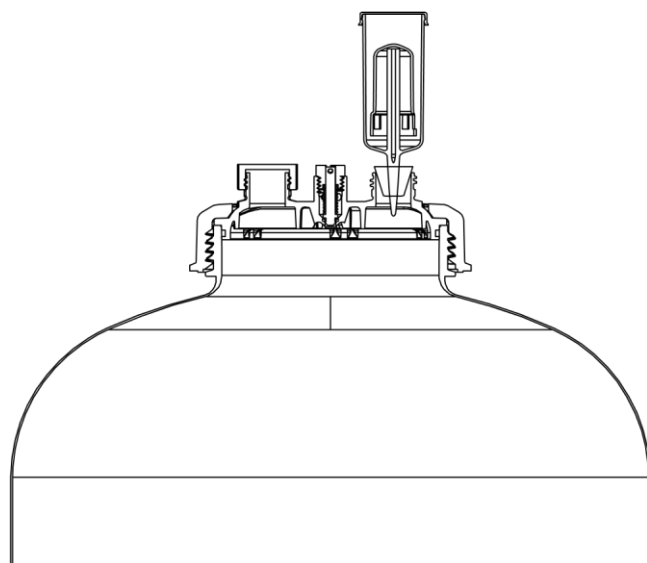

2. Cleaning and sanitizing the fermenter and equipment

Cleaning the FermZilla all-rounder

1. Rinse the walls of the FermZilla vessel with cold water. A garden hose is particularly useful for rinsing and dislodging yeast/hop matter.
2. Fill the FermZilla with cold water and add StellarClean according to the instructions on the tub. Any other dirty brewing equipment can also be soaked in the fermenter.
3. StellarClean can be left in the vessel for up to 30 minutes.
4. After 30 minutes of soaking with StellarClean, gently wipe away any soiling with a soft cloth. Make sure not to use harsh scrubbers that may scratch the plastic and create ideal places for batch-ruining bacteria to hide.
5. Once the fermenter is clean, rinse the PBW out with warm water.



6. Fill the FermZilla and collection vessel with cold water again and add StellarSan according to the instructions on the bottle. Attach the lid and shake the full FermZilla to coat all surfaces.
7. StellarSan can be left in the vessel until the next fermentation when it can be emptied and your wort added. But we prefer to fill with 2L of water and 3mL of StellarSan just prior to filling the FermZilla.

Cleaning the Pressure Relief Valve (PRV)

It is important to regularly clean the PRV to ensure that no beer has dried onto the PRV for example from a very active fermentation or from moving the all-rounder. If wort or beer has dried on to the PRV it can result in the spring within the PRV not opening when required if the pressure in the vessel gets above 35 psi.

To clean the PRV simply unscrew it from the lid and soak in StellarClean for 30 minutes, then rinse and soak in StellarSan or spray the internal surface with Super Kill Ethyl sanitiser spray. An easy way to add cleaning the PRV to your cleaning regime is to simply remove the PRV and place it into the cleaning/sanitising solution in the FermZilla.

Cleaning a BlowTie Spunding Valve (If applicable)

If fermenting under pressure and fermentation has been particularly active and krausen or beer has entered the BlowTie Spunding Valve you will need to disassemble the BlowTie and clean it to ensure that it operates correctly and releases pressure above the set pressure.

Follow these steps to disassemble and clean a BlowTie Spunding Valve:

1. Completely remove the yellow adjustment knob and spring.
2. Unscrew the four large screws on the face of the Blowtie Spunding Valve and the two small screws on the housing of the integrated pressure gauge.
3. Remove the integrated pressure gauge housing and the integrated pressure gauge by gently pulling up on the dial.
4. Remove the face of the BlowTie Spunding Valve.
5. Remove the diaphragm assembly.
6. Remove the collets on the duotight fittings.
7. Remove the o-rings within the duotight fittings.
8. Soak all components in StellarClean solution for 30 minutes and then reassemble.



[BlowTie Spunding Valve Breakdown Cleaning Video](#)

3. Conducting a Leak/Pressure Test (if fermenting under pressure)

If you are planning to ferment under pressure it is essential to conduct a leak test before adding wort to the FermZilla to ensure that the FermZilla will hold pressure throughout fermentation

A leak test can be conducted via multiple methods which are outlined below. It is a good idea to perform both of the pressure test methods to be certain your all-rounder is holding pressure with no leaks.

1. Pressure decay test

Step 1. Ensure the all-rounder is empty and the pressure lid is firmly in place with the lid ring hand tight.

Step 2. Set the pressure in the all-rounder to the highest pressure you will be fermenting at using your CO₂ cylinder and regulator. This will usually be between 10-15psi.

Step 3. Remove and swap the gas supply grey ball lock disconnect for a blowtie spunding valve set at between 10-15psi.

Step 4. Leave the all-rounder to sit with the spunding valve attached for a few hours (overnight is preferred). Then check if the pressure on the gauge of the spunding valve has decreased from its set pressure.

If the pressure has dropped then this indicates that there is a leak in the system. The source of this leak needs to be determined and fixed before proceeding with pressure fermentation.

Note: If the all-rounder is not empty during this test it can result in a false positive result as the CO₂ will dissolve into solution. Hence it is essential this is performed with the all-rounder is empty.

2. Bubble Test

Step 1. Ensure the all-rounder is empty and the pressure lid is firmly in place with the lid ring hand tight.

Step 2. Set the pressure in the all-rounder to the highest pressure you will be fermenting at using your CO₂ cylinder and regulator. This will usually be between 10-15psi.



Step 3. Spray all connections with soapy water and look for the formation of bubbles. This includes all push fit connections and connections between the regulator and CO2 cylinder.

If bubbles are formed at any of these connections this indicates a leak which needs to be fixed. Alternatively, the all-rounder can be pressurised and then disconnect from gas and the lid of the allrounder submerged in water. The formation of bubbles in the water indicates the presence of a leak.

The following instruction manual will assist with identifying and fixing leaks on the FermZilla.

[FermZilla Leak Fix Instruction Manual](#)

For a comprehensive guide to pressure fermentation have read through the following blog post:

<https://www.kegland.com.au/blog/post/a-comprehensive-guide-to-pressure-fermentation>

4. Hydro-Test Instructions

The expiry-date of the PET tank is stamped on the body of the FermZilla as shown below:

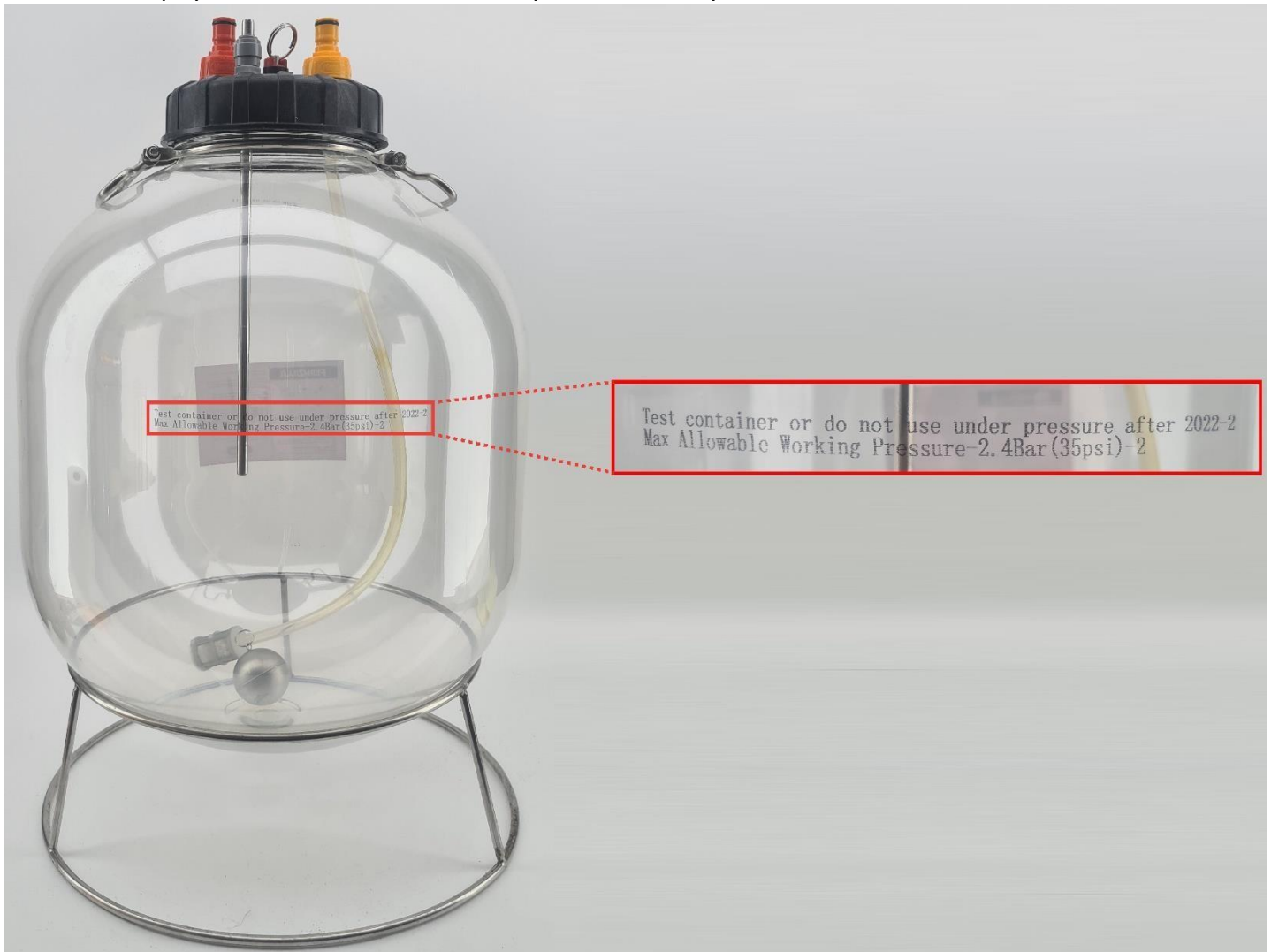

FermZilla's which are past their expiry date should not be used under any pressure until they have passed a hydro test.

Instructions on how to safely conduct a hydro test can be found in the pdf below:

[FermZilla Hydro Test Instruction Manual](#)

Suggested Additional Equipment

Looking to improve your kit and have the right gear on hand to do the job in the best possible way?

- KL05371 Ethyl Kill Sanitiser Spray
- KL05357 Stellarsan 500mL
- KL07405 StellarOxy 1kg
- KL05494 StellarClean Powerful Brewery Wash (PBW) 1kg *See warnings (page 3 9.D)*
- KL05289 Heavy Duty Brewing Gloves
- KL01946 Digital Temperature Controller
- **Recommended** KL26031 Fermentation Heating Wrap
 - **OR** KL01960 Heating Wrap
 - **OR** KL01953 Heating Belt
- KB02113 FermZilla Pressure Kit
 - 1 x KL10788 Red Carbonation Cap (Gas Ball Lock Post)
 - 1 x KL10788-Yellow Yellow Carbonation Cap (Liquid Ball Lock Post)
 - 1 x KL14076 80cm Silicone Dip tube with Stainless Steel Float
 - 1 x KL16957 Floating Dip Tube Filter
- KB03529 duotight – Blowtie Spunding Valve Kit with integrated 0-15psi Mini Gauge
 - **OR** KL09706 Blowtie with larger gauge kit
- KL13567 Base Support/Webbing/Strap
- KL14649 60cm Thermowell Kit
 - **Recommended** KL14557 Red Pipe Cutter (to trim down for 30L All Rounder)



Premium Equipment Recommendations

- KL15813 [RAPT Fermentation Chamber](#) (For the absolute best control and tested profile management of your fermentations, the RAPT chamber is the best you can get)
- OR KL22927 [RAPT Temperature Controller](#)
- In conjunction with the above Controller or Chamber KL20596 [Yellow RAPT Pill – Hydrometer & Thermometer \(Wifi & Bluetooth\)](#). Accurately measure and log the specific gravity and temperature of your fermentation in real time.
-

Support

Please join the KegLand Home Brew Community Group Facebook pages for support on how to use your FermZilla, recipes or tips and tricks. If you need hardware support, please contact your nearest FermZilla distributor.

Warranty (Australia)

The FermZilla 30L and 60L all-rounder comes with a 12 months Warranty when sold in Australia.

To lodge a warranty claim in Australia please forward as many visual pieces of supporting information and a detailed description of your issue to beer@kegland.com.au

If you purchased your unit from an international distributor, you will be required to go through their warranty claims process.

For full terms and conditions, please visit our website here -> [Terms & Conditions](#)