

# 280™ HEAVY DUTY CARTRIDGE DUAL SEAL

## SEAL INSTALLATION

### Preparation

**Determine if the pump is in good condition.**

#### A. Check the shaft or sleeve.

1. Remove all burrs and sharp corners, especially in areas where the o-ring has to slide. Cover threads and keyway slots with a thin tape to prevent cutting the o-ring. The distance from the stuffing box face to the center of the o-ring groove is approximately: 1.50" (38,1 mm) for 1.000" through 2.500" (25 mm through 60 mm); 2.00" (50,8 mm) for 2.625" through 4.750" (65 mm through 120 mm); 3.00" (76,2 mm) for 5.000" through 8.000" (130 mm through 200 mm); 4.00" (101,6 mm) for 8.250" through 12.000" (210 mm through 300 mm).
2. The shaft finish should be 32 microinches RA (0,8 microns) maximum. It should feel smooth if you run your fingernail down it axially.
3. **Make sure the shaft or sleeve diameter is within +/- .002" (0,05 mm) of nominal.**
4. Use a dial indicator to measure the shaft runout in the area where the seal is to be installed. (**Readings should not exceed .001" (0,03 mm) TIR per inch of shaft diameter.**)
5. Place the dial indicator on the end of the shaft and alternately push and pull the shaft axially to measure end play. End play should not exceed .005" (0,12 mm) TIR.
6. Protect the sleeve o-ring by lubricating the shaft with a clean silicone based lubricant, as that provided with the seal.

#### B. Check the stuffing box.

1. The stuffing box face must be a maximum of 125 microinches RA (3,2 microns) for a gasket to seal.
2. Split case pumps will sometimes cause a step (misalignment) to occur on the stuffing box face. This step must be machined flat.

3. Make sure the stuffing box is clean and clear along its entire length.
4. If possible, attach a base dial indicator to the shaft and rotate both the indicator and shaft slowly while reading the runout of the stuffing box face. Misalignment of the stuffing box face relative to the shaft should not exceed .005" (0,12 mm) TIR per inch of shaft diameter.

### Installation

1. Check the chemical listing to determine if the o-rings installed in this seal are compatible with the fluid being sealed.
2. The 1/4 dog point set screws go into the small holes in the sleeve. Do not disengage these screws from the sleeve when positioning the seal. The cup point set screws go through the larger holes in the sleeve. Make sure all screws are engaged in the sleeve but do not protrude into the ID bore. Also, when repositioning or removing the seal, make sure the centering clips and socket head cap screws are engaged.
3. The centering clips have been preset at the factory. If for any reason you loosen or remove the centering clip cap screws, re-tighten each cap screw finger tight (approximately 15 inch-pounds [1,7 Nm] of torque). **Make sure that the lip on the end of the centering clip is inside the gland groove.**
4. **CAUTION:** If the seal is operating at a stuffing box pressure over 300 psig (20 bar) or the shaft is case hardened, replace the 316SS cup point set screws with the hardened steel cup point screws supplied with the seal.
5. Slide the seal onto the shaft making sure the 1/4 dog point set screws are engaged through the seal sleeve.
6. Reassemble the pump and make necessary shaft alignments and impeller adjustments. The impeller can be reset at any time, as long as the centering

clips are in place and the seal set screws are loosened while the shaft is being moved.

7. Orient the barrier fluid connections to the location required. The ports are plugged prior to shipping. Remove plugs.
8. Piping connections should not be made prior to tightening the gland bolts.
9. Tighten the gland bolts evenly. **IMPORTANT: The gland bolts must be tightened before tightening the set screws onto the shaft.**
10. **IMPORTANT: All 1/4 dog point set screws must be tightened FIRST.** See figures 1 and 2 below for location of dog point set screws. If rotation of the lock ring is required for tightening set screws, loosen or remove one centering clip. Finger tighten each 1/4 dog point set screw by twisting the short end of the hex key with your finger tips. Then tighten each 1/4 dog point set screw per the recommended tightening torque shown on the chart at the bottom of page 2.
11. Once the 1/4 dog point set screws are tightened, finger tighten each set screw by twisting the short end of the hex key with your finger tips until the point of each set screw touches the shaft. Then tighten each set screw per recommended tightening torque shown on the chart at the bottom of page 2.
12. Remove socket head cap screws and centering clips. Retain for later use.
13. **IMPORTANT: It is important to make sure that the gland is properly centered over the sleeve.** To do this, turn the shaft by hand to make sure the seal turns freely. If you hear metal to metal contact within the seal, it was improperly centered. Replace the centering clips finger tight, loosen gland bolts, tighten clips, re-tighten gland bolts, and then remove clips. If metal to metal contact still exists, check the centering of the stuffing box.

## SEAL INSTALLATION

14. Piping connections should not be made until the gland nuts are tightened.
15. The **BARRIER FLUID CONNECTIONS** are 1/4" NPT for 1.00" through 1.50" (25 mm through 38 mm), 3/8" NPT for 1.625" through 2.50" (40 mm through 60 mm), 1/2" NPT for 2.625" through 8.00" (65 mm through 200 mm), and 3/4" NPT for 8.25" through 12.00" (210 mm through 300 mm).
16. This seal is equipped with a pumping device to circulate the barrier fluid. **(The piping connections are dependent on shaft rotation.)** Direction of shaft rotation is determined when looking at the lock ring end of the seal.

### Convection

(when ports are positioned at 12:00)

#### A. CLOCKWISE shaft rotation

The cool fluid from the bottom of the convection tank enters through the right port. The hot fluid exits the seal through the left port and goes to the top of the convection tank. Add fluid, typically 50/50 ethylene glycol and water or Chesterton 610 Synthetic Lubricating Oil, to the convection tank.

#### B. COUNTER-CLOCKWISE shaft rotation

The cool fluid from the bottom of the convection tank enters through the left port. The hot fluid exits through the right port and goes to the top of the convection tank. Take all necessary precautions and follow normal safety procedures before starting equipment.

Add fluid, typically 50/50 ethylene glycol and water or Chesterton 610 Synthetic Lubricating Oil, to the convection tank.

### Forced Circulation

(when ports are positioned at 12:00)

#### A. CLOCKWISE shaft rotation

The cool fluid enters through the right port. The hot fluid exits through the left port.

#### B. COUNTER-CLOCKWISE shaft rotation

The cool fluid enters through the left port. The hot fluid exits through the right port. Take all necessary precautions and follow normal safety procedures before starting equipment.

## SCREW AND BOLT TORQUE

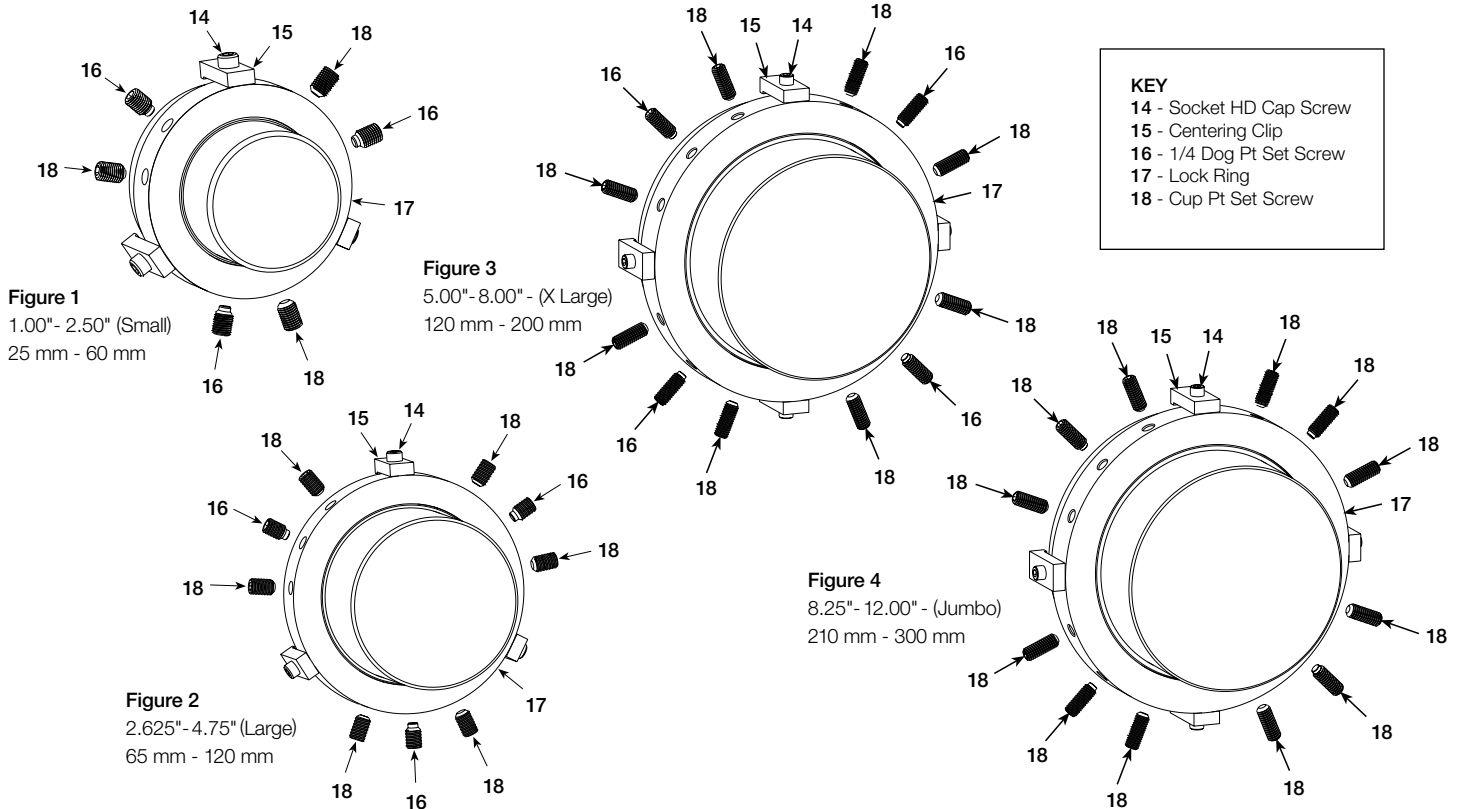

SEAL SIZE	DOG POINT SET SCREWS	CUP POINT SET SCREWS	STUFFING BOX BOLTS
up to 2.50" (60 mm)	50-60 in-lbf (5,7-6,8 Nm)	50-60 in-lbf (5,7-6,8 Nm)	20-30 ft-lbf (27-40 Nm)
up to 4.75" (120 mm)	65-75 in-lbf (7,3-8,3 Nm)	65-75 in-lbf (7,3-8,3 Nm)	25-35 ft-lbf (34-48 Nm)
up to 8.00" (200 mm)	120-135 in-lbf (13,6-15,3 Nm)	120-135 in-lbf (13,6-15,3 Nm)	40-60 ft-lbf (54-81 Nm)
up to 12.00" (300 mm)	None	290-310 in-lbf (32,8-35,0 Nm)	As required

## CAUTIONS

These instructions are general in nature. It is assumed that the installer is familiar with seals and certainly with the requirements of their plant for the successful use of mechanical seals. If in doubt, get assistance from someone in the plant who is familiar with seals or delay the installation until a seal representative is available. All necessary auxiliary arrangements

for successful operation (heating, cooling, flushing) as well as safety devices must be employed. These decisions are to be made by the user. The chemical listing is intended as a general reference for this seal only. The decision to use this seal or any other Chesterton seal in a particular service is the customer's responsibility.

# PARTS IDENTIFICATION

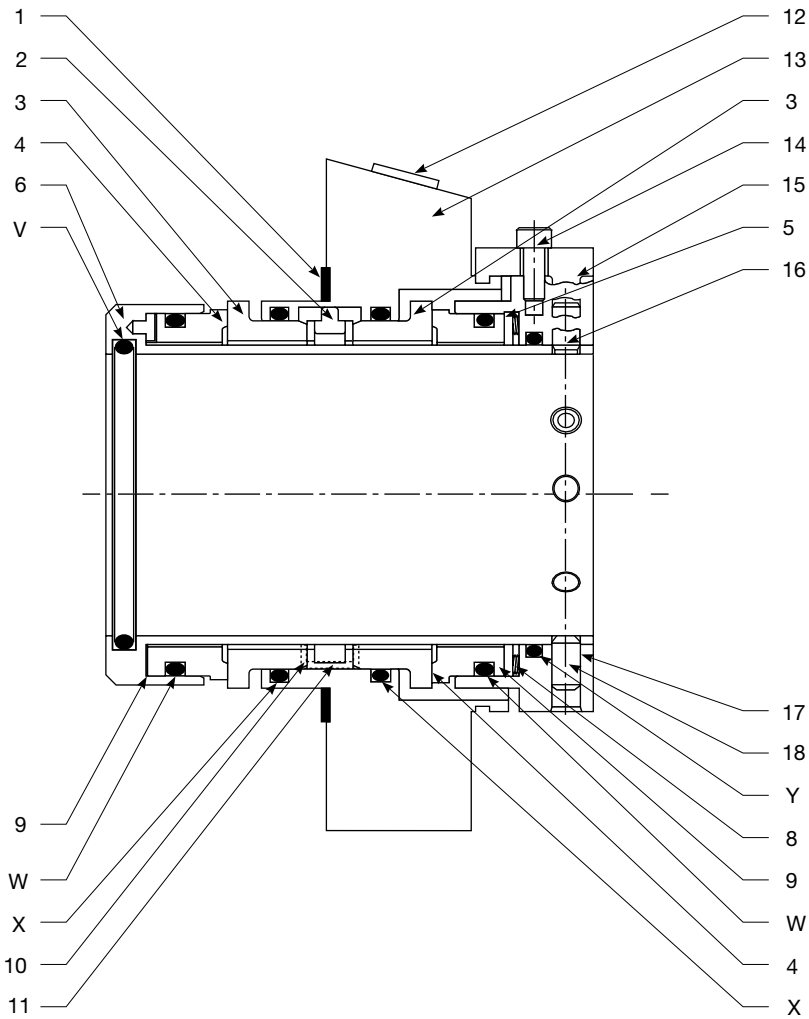

## STANDARD MATERIALS\*\*

**All Metal Parts:** 316 SS.

**Springs:** Hastelloy C\*

**O-Rings:** Fluorocarbon, AFLAS† or EPR installed

**Rotary Face:** Carbon, Silicon Carbide, Tungsten Carbide

**Stationary Face:** Silicon Carbide, Tungsten Carbide

**Temperature:** To 300°F (150°C)

Ethylene Propylene, to 400°F (205°C)

Fluorocarbon, AFLAS, to 500°F (260°C)

Perfluoroelastomer.

**Speed:** To 4000 FPM (20 mps).

**Pressure:** To 600 psi (40 bar) inboard, 250 psi (17 bar) outboard, up to 4.75" (120 mm) shaft size.

To 300 psi (20 bar) inboard, 200 psi (13 bar) outboard, up to 12.00" (300 mm) shaft size.

**Minimum Barrier Fluid Pressure:** 30 psi (2 bar) minimum barrier fluid pressure is recommended to properly lubricate outboard seal.

\*Haynes International, Inc. Registered Trademark.

\*\*Other materials available upon request.

†Asahi Glass Company Ltd. Registered Trademark.

### KEY

- |                       |                            |
|-----------------------|----------------------------|
| 1 - Gasket            | 13 - Gland                 |
| 2 - Lug               | 14 - Socket Head Cap Screw |
| 3 - Stationary Face   | 15 - Centering Clip        |
| 4 - Rotary Face       | 16 - 1/4 Dog Pt. Set Screw |
| 5 - Follower Assembly | 17 - Lock Ring             |
| 6 - Sleeve Assembly   | 18 - Set Screw             |
| 8 - Spring            | V - Shaft O-Ring           |
| 9 - Rotary Gasket     | W - Rotary O-Ring          |
| 10 - Channel Clip     | X - Stationary O-Ring      |
| 11 - Channel          | Y - Lock Ring O-Ring       |
|                       |                            |

## 280 STANDARD DIMENSIONAL DATA (INCH)

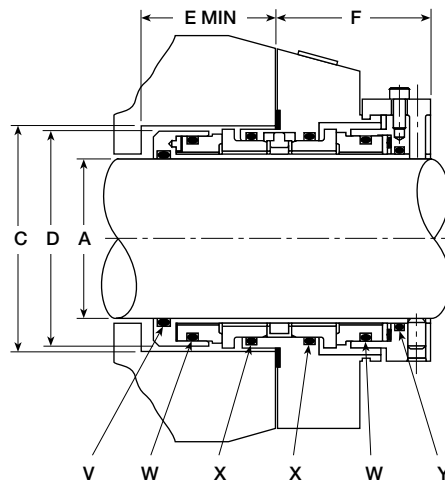
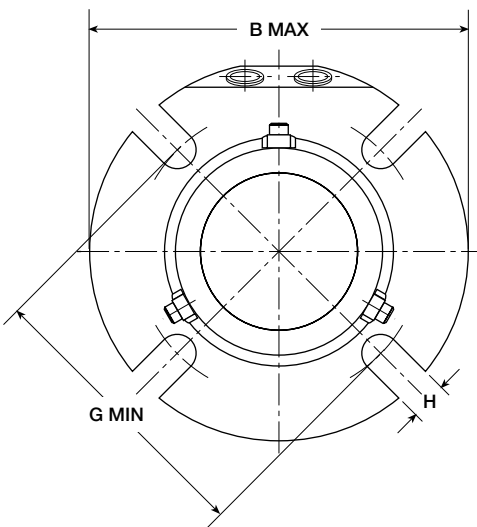

### KEY

- |                                      |
|--------------------------------------|
| A - Shaft Size                       |
| B - Maximum Gland Diameter           |
| C - Stuffing Box Inside Diameter     |
| D - Seal Diameter in Stuffing Box    |
| E - Minimum Stuffing Box Depth       |
| F - Outboard Seal Length             |
| G - Minimum Bolt Circle by Bolt Size |
| H - Slot Width                       |
| V - Shaft O-Ring                     |
| W - Rotary O-Ring                    |
| X - Stationary O-Ring                |
| Y - Lock Ring O-Ring                 |

ASSEMBLY / DISASSEMBLY

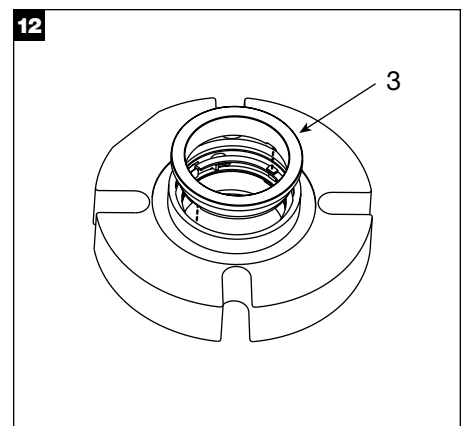
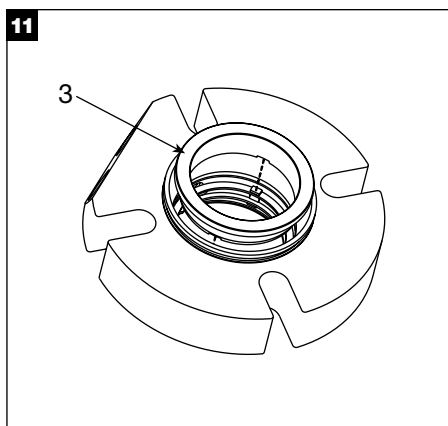
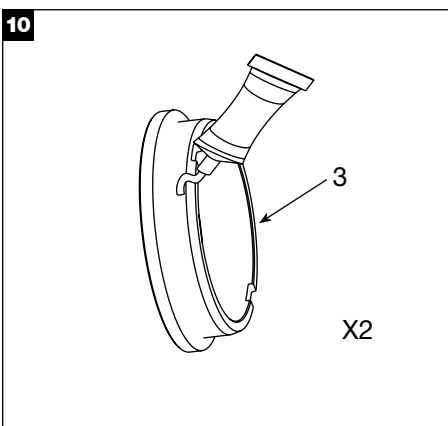
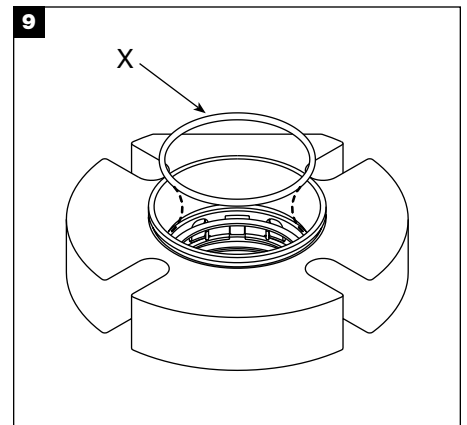
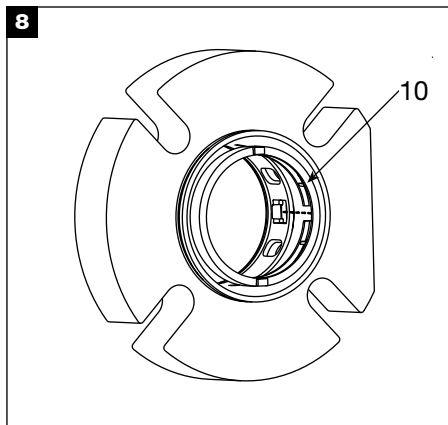
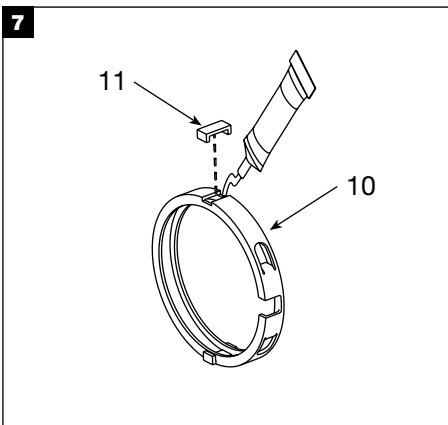
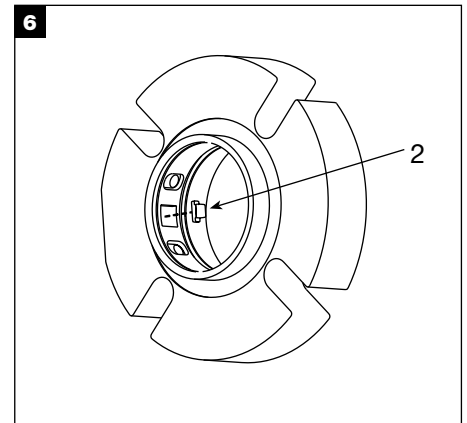
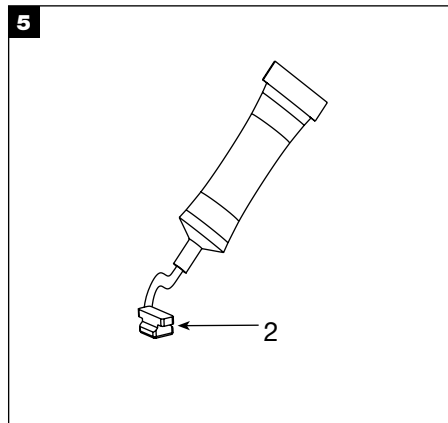
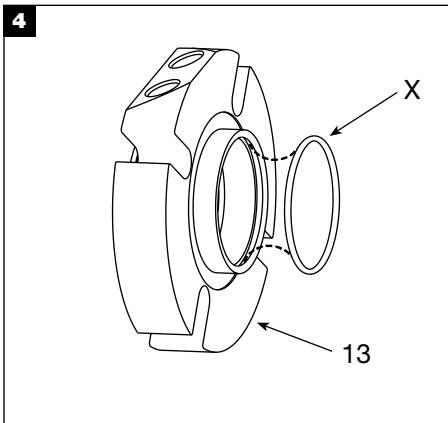
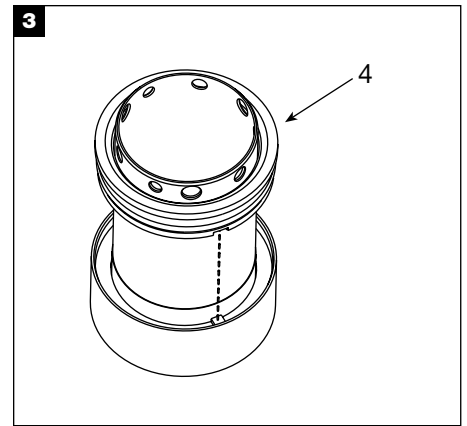
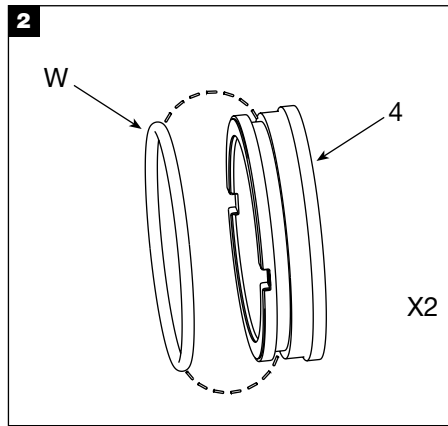
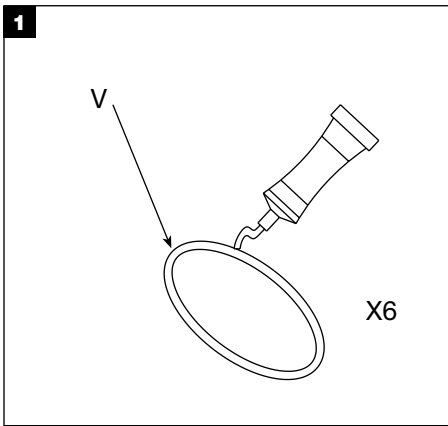

ASSEMBLY / DISASSEMBLY

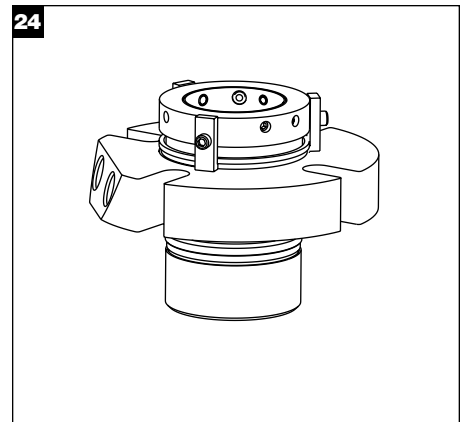
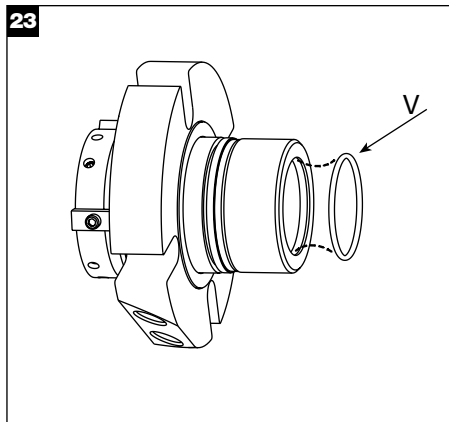
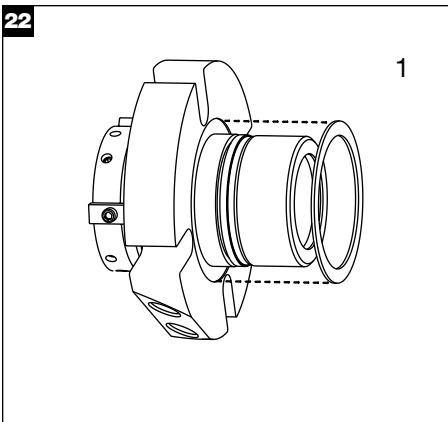
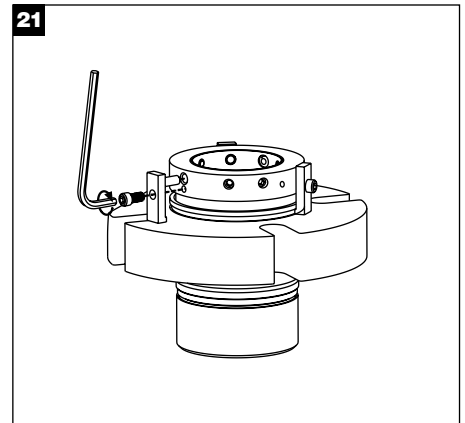
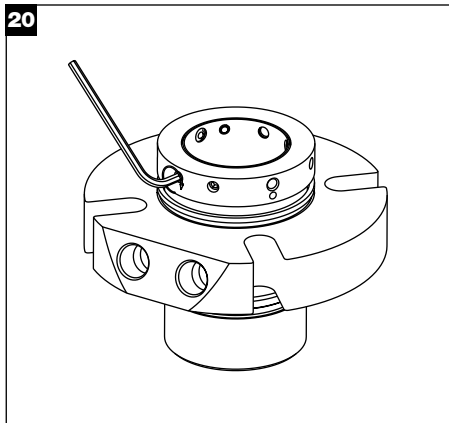
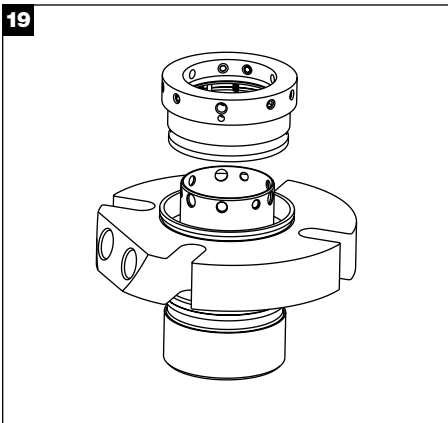
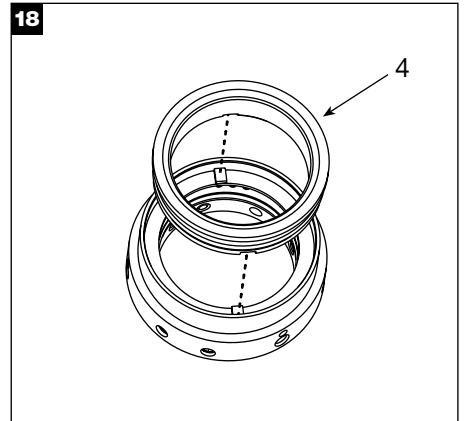
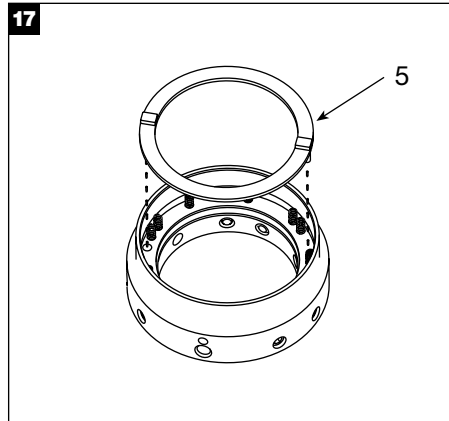
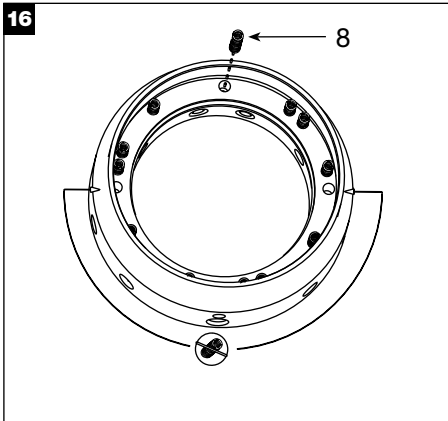
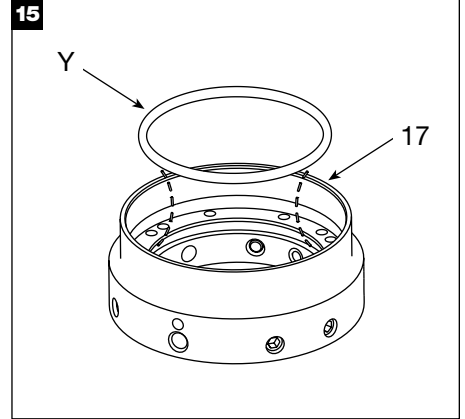
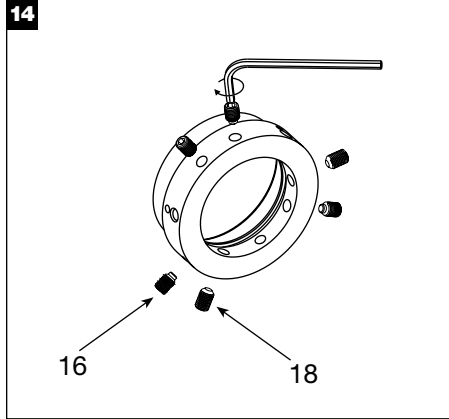
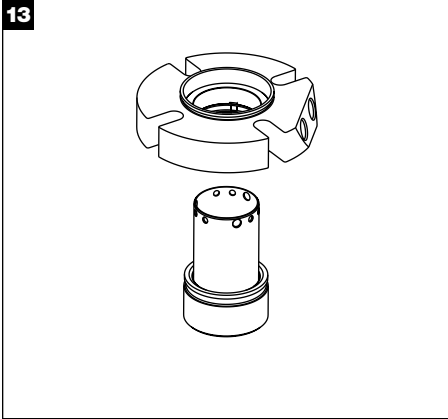

## 280 STANDARD AND OVERSIZE DIMENSIONAL DATA (INCH)

DASH NO.	SHAFT SIZE	GLAND OD	STUFFING BOX BORE		IB SEAL DIA	SB DEPTH	OB LENGTH	BOLT CIRCLE BY BOLT SIZE				SLOT WIDTH	O-RINGS					
													SHAFT	ROTARY	STATIONARY	LOCK RING		
								A	B MAX	C MIN	C MAX		D MAX	E MIN	F MAX	G MIN		
							3/8"	1/2"	5/8"	3/4"	7/8"							
-8	1.000	4.11	1.75	2.01	1.73	1.58	2.13	2.88					0.44	120	126	127	122	
-9	1.125	4.11	1.88	2.04	1.85	1.58	2.13	2.88					0.44	122	128	129	124	
-10	1.250	4.11	2.00	2.27	1.98	1.58	2.13	3.14					0.44	124	130	131	126	
-11	1.375	4.36	2.13	2.33	2.10	1.58	2.13	3.13	3.25				0.57	126	132	133	128	
-11OS	1.375	5.40	2.81	3.00	2.80	1.58	2.13	4.03					0.43	126	132	133	128	
-12	1.500	4.49	2.25	2.44	2.23	1.58	2.13	3.33	3.45				0.57	128	134	135	130	
-13	1.625	4.99	2.38	2.69	2.35	1.58	2.13	3.52	3.65				0.57	130	136	137	132	
-14	1.750	5.49	2.50	2.81	2.48	1.58	2.13	3.65	3.77				0.57	132	138	139	134	
-14OS	1.750	6.64	3.50	3.75	3.49	1.58	2.13	5.21	5.33	5.46			0.74	132	138	139	134	
-15	1.875	5.49	2.63	2.94	2.60	1.58	2.13	3.78	3.90				0.57	134	140	141	136	
-15OS	1.875	5.99	3.56	3.81	3.54	1.58	2.13		5.00				0.63	134	140	141	136	
-16	2.000	5.49	2.75	3.19	2.73	1.58	2.13	4.03	4.15				0.57	136	142	143	138	
-17	2.125	5.99	2.88	3.44	2.85	1.58	2.13	4.28	4.41	4.53			0.69	138	144	145	140	
-17OS	2.125	6.99	3.88	4.25	3.87	1.58	2.13		5.95				0.75	138	144	145	140	
-18	2.250	5.99	3.00	3.56	2.98	1.58	2.13	4.40	4.53	4.65			0.69	140	146	147	142	
-19	2.375	5.99	3.13	3.59	3.10	1.58	2.13	4.46	4.59	4.71			0.69	142	148	149	144	
-20	2.500	6.49	3.25	3.81	3.23	1.58	2.13	4.65	4.78	4.90			0.69	144	150	151	146	
-20OS	2.500	7.77	4.50	4.75	4.49	1.58	2.13		6.75				0.75	144	150	151	146	
-21	2.625	6.45	3.63	3.93	3.60	2.05	2.50		5.02	5.15			0.69	231	235	236	149	
-21OS	2.625	6.98	4.55	4.88	4.54	2.05	2.50		6.00				0.69	231	235	236	149	
-22	2.750	7.70	3.75	4.44	3.73	2.05	2.50		5.42	5.55			0.69	232	236	237	151	
-22OS	2.750	7.89	4.45	4.56	4.44	2.05	2.50				6.38		0.81	232	236	237	151	
-23	2.875	7.83	3.88	4.56	3.85	2.05	2.50		5.50	5.62			0.69	233	237	238	151	
-24	3.000	7.94	4.00	4.69	3.97	2.05	2.50		5.65	5.77			0.69	234	238	239	152	
-24OS	3.000	8.64	4.93	5.17	4.92	2.05	2.50			7.00	7.13	7.25	0.94	234	238	239	152	
-25	3.125	7.99	4.13	4.81	4.10	2.05	2.50		5.80	5.92			0.69	235	239	240	152	
-26	3.250	8.19	4.25	4.94	4.22	2.05	2.50		5.93	6.05			0.69	236	240	241	153	
-27	3.375	8.30	4.38	5.06	4.35	2.05	2.50		6.02	6.14			0.81	237	241	242	153	
-27OS	3.375	8.39	4.95	5.06	4.94	2.05	2.50				6.27		6.88	0.82	237	241	242	153
-28	3.500	8.44	4.50	5.19	4.47	2.05	2.50		6.18	6.31	6.43		0.81	238	242	243	154	
-29	3.625	8.49	4.63	5.31	4.60	2.05	2.50		6.31	6.44	6.56		0.81	239	243	244	155	
-30	3.750	8.71	4.75	5.44	4.72	2.05	2.50		6.38	6.51	6.63		0.81	240	244	245	155	
-30OS	3.750	9.76	5.08	6.18	5.07	2.05	2.50			8.25			0.82	240	244	245	155	
-31	3.875	8.84	4.88	5.56	4.85	2.05	2.50		6.52	6.64	6.77		0.81	241	245	246	155	
-32	4.000	8.96	5.00	5.69	4.97	2.05	2.50		6.66	6.78	6.91		0.81	242	246	247	156	
-33	4.125	8.99	5.13	5.81	5.10	2.05	2.50		6.79	6.90	7.03		0.81	243	247	248	156	
-33OS	4.125	9.76	5.95	6.06	5.94	2.05	2.50					8.00	0.82	243	247	248	156	
-34	4.250	8.99	5.25	5.94	5.22	2.05	2.50		6.91	7.04	7.16		0.81	244	248	249	157	
-35	4.375	9.33	5.38	6.06	5.35	2.05	2.50		7.03	7.15	7.28		0.81	245	249	250	157	
-36	4.500	9.49	5.50	6.19	5.47	2.05	2.50		7.18	7.30	7.43		0.81	246	250	251	158	
-36OS	4.500	12.49	6.75	7.25	6.75	2.05	2.50				10.76		0.88	246	250	251	158	
-37	4.625	9.49	5.63	6.31	5.60	2.05	2.50		7.28	7.40	7.53		0.81	247	251	252	158	
-38	4.750	10.49	5.75	6.44	5.72	2.05	2.50		7.40	7.53	7.65		0.81	248	252	253	159	
-38OS	4.750	11.39	7.20	7.42	7.19	2.05	2.50			9.88	10.00		0.82	248	252	253	159	

## 280 STANDARD DIMENSIONAL DATA (METRIC)

SHAFT SIZE	GLAND OD	STUFFING BOX BORE		IB SEAL DIA	SB DEPTH	OB LENGTH	BOLT CIRCLE BY BOLT SIZE				SLOT WIDTH	O-RINGS					
												SHAFT	ROTARY	STATIONARY	LOCK RING		
							A	B MAX	C MIN	C MAX		D MAX	E MIN	F MAX	G MIN		
							10 MM	12 MM	16 MM	20 MM							
25	104	44	51	44	40	54		73					11	120	126	127	121
28	104	47	52	47	40	54		73					11	122	128	129	123
30	104	49	56	49	40	54		78					11	123	129	130	125
32	104	51	57	51	40	54		80					11	124	130	131	126
33	113	52	58	52	40	54		81		83			14	125	131	132	127
35	111	54	59	54	40	54		80		82			14	126	132	133	128
38	114	57	61	57	40	54		85		87			14	128	134	135	130
40	127	59	68	59	40	54		90		92			13	129	135	136	131
43	127	62	68	62	40	54		91		93			13	131	137	138	133
45	139	64	73	64	40	54		95		97			13	133	139	140	134
48	139	67	73	67	40	54		96		98			13	134	141	142	136
50	139	69	78	69	40	54		100		102			13	136	142	143	137
55	152	74	83	74	40	54		105		107	111		17	139	145	146	140
60	152	79	91	79	40	54		114		116	120		17	142	148	149	143
65	164	92	100	91	52	63				127	131		17	231	235	236	148
70	196	96	113	95	52	63				137	141		17	232	236	237	151
75	202	102	119	101	52	63				143	147		17	234	238	239	5-557
80	203	106	122	105	52	63				150	154		17	236	239	240	153
85	211	111	129	110	52	63				152	156	161	21	237	241	242	153
90	214	116	132	115	52	63				160	164	168	21	239	242	243	154
95	221	121	138	120	52	63				161	165	170	21	240	244	245	155
100	228	127	144	126	52	63				168	172	177	21	242	246	247	5-833
110	237	137	154	136	52	63				178	182	186	21	245	249	250	157
120	266	146	163	145	52	63				187	191	195	21	248	252	253	5-403

## 280 MIXER DIMENSIONAL DATA (INCH)

DASH NO.	SHAFT SIZE	GLAND OD	STUFFING BOX BORE		IB SEAL DIA	SB DEPTH	OB LENGTH	BOLT CIRCLE BY BOLT SIZE			SLOT WIDTH	O-RINGS			
												SHAFT	ROTARY	STATIONARY	LOCK RING
								A	B MAX	C MIN		C MAX	D MAX	E MIN	F MAX
									3/8"	1/2"	5/8"				
-8	1.000	4.11	2.00	2.04	1.85	1.58	2.13	2.88			0.44	120	128	129	124
-9	1.125	4.11	2.12	2.27	1.98	1.58	2.13	3.14			0.44	122	130	131	126
-10	1.250	4.36	2.25	2.33	2.10	1.58	2.13	3.14	3.26		0.57	124	132	133	128
-11	1.375	4.49	2.37	2.44	2.23	1.58	2.13	3.33	3.46		0.57	126	134	135	130
-12	1.500	4.99	2.50	2.69	2.35	1.58	2.13	3.53	3.66		0.57	128	136	137	132
-13	1.625	5.49	2.62	2.81	2.48	1.58	2.13	3.65	3.78		0.57	130	138	139	134
-14	1.750	5.49	2.75	2.94	2.60	1.58	2.13	3.78	3.91		0.57	132	140	141	136
-15	1.875	5.49	2.87	3.19	2.73	1.58	2.13	4.03	4.16		0.57	134	142	143	138
-16	2.000	5.99	3.00	3.44	2.85	1.58	2.13	4.28	4.41	4.53	0.69	136	144	145	140
-17	2.125	5.99	3.12	3.56	2.98	1.58	2.13	4.40	4.53	4.65	0.69	138	146	147	142
-18	2.250	5.99	3.25	3.62	3.10	1.58	2.13	4.46	4.59	4.71	0.69	140	148	149	144
-19	2.375	6.49	3.37	3.81	3.23	1.58	2.13	4.65	4.78	4.90	0.69	142	150	151	146
								1/2"	5/8"	3/4"					
-20	2.500	7.70	4.00	4.44	3.73	2.05	2.50	5.42	5.55		0.69	230	236	237	151
-21	2.625	7.83	4.12	4.56	3.86	2.05	2.50	5.50	5.62		0.69	231	237	238	151
-22	2.750	7.94	4.25	4.69	3.97	2.05	2.50	5.65	5.77		0.69	232	238	239	152
-23	2.875	7.99	4.37	4.81	4.10	2.05	2.50	5.80	5.92		0.69	233	239	240	152
-24	3.000	8.19	4.50	4.94	4.22	2.05	2.50	5.93	6.05		0.69	234	240	241	153
-25	3.125	8.30	4.62	5.06	4.35	2.05	2.50	6.02	6.14	6.27	0.81	235	241	242	153
-26	3.250	8.44	4.75	5.19	4.47	2.05	2.50	6.18	6.31	6.43	0.81	236	242	243	154
-27	3.375	8.49	4.87	5.31	4.60	2.05	2.50	6.31	6.44	6.56	0.81	237	243	244	154
-28	3.500	8.71	5.00	5.44	4.72	2.05	2.50	6.38	6.51	6.63	0.81	238	244	245	155
-29	3.625	8.84	5.12	5.56	4.85	2.05	2.50	6.52	6.64	6.77	0.81	239	245	246	155
-30	3.750	8.96	5.25	5.69	4.97	2.05	2.50	6.66	6.78	6.91	0.81	240	246	247	156
-31	3.875	8.99	5.37	5.81	5.10	2.05	2.50	6.79	6.90	7.03	0.81	241	247	248	156
-32	4.000	8.99	5.50	5.94	5.22	2.05	2.50	6.91	7.05	7.16	0.81	242	248	249	157
-33	4.125	9.33	5.62	6.06	5.35	2.05	2.50	7.03	7.15	7.28	0.81	243	249	250	157
-34	4.250	9.49	5.75	6.19	5.47	2.05	2.50	7.18	7.30	7.43	0.81	244	250	251	158
-35	4.375	9.49	5.87	6.31	5.60	2.05	2.50	7.28	7.40	7.53	0.81	245	251	252	158
-36	4.500	10.49	6.00	6.44	5.72	2.05	2.50	7.40	7.53	7.65	0.81	246	252	253	159
								7/8"	1"	1 1/8"					
-38	4.75	10.98	6.75	6.38	3.25	4.09	8.92	9.04	9.17		351	359	361	253	
-40	5.00	11.23	7.00	6.63	3.25	4.09	9.17	9.29	9.42		353	361	362	255	
-42	5.25	11.48	7.25	6.88	3.25	4.09	9.42	9.54	9.67		355	362	363	257	
-44	5.50	11.73	7.50	7.13	3.25	4.09	9.67	9.79	9.92		357	363	364	259	
-46	5.75	11.98	7.75	7.38	3.25	4.09	9.92	10.04	10.17		359	364	365	260	
-48	6.00	12.23	8.00	7.63	3.25	4.09	10.17	10.29	10.42		361	365	366	261	
-50	6.25	12.48	8.25	7.88	3.25	4.09	10.42	10.54	10.67		362	366	367	262	
-52	6.50	12.73	8.50	8.13	3.25	4.09	10.67	10.79	10.92		363	367	368	263	
-54	6.75	12.98	8.75	8.38	3.25	4.09	10.92	11.04	11.17		364	368	369	264	
-56	7.00	13.23	9.00	8.63	3.25	4.09	11.17	11.29	11.42		365	369	370	265	
-58	7.25	13.48	9.25	8.88	3.25	4.09	11.42	11.54	11.67		366	370	371	266	
-60	7.50	13.73	9.50	9.13	3.25	4.09	11.67	11.79	11.92		367	371	372	267	
-62	7.75	13.98	9.75	9.38	3.25	4.09	11.92	12.04	12.17		368	372	373	268	
-64	8.00	14.23	10.00	9.63	3.25	4.09	12.17	12.29	12.42		369	373	374	269	

## 280 MIXER DIMENSIONAL DATA (METRIC)

SHAFT SIZE	OD	STUFFING BOX BORE		IB SEAL DIA	SB DEPTH	OB LENGTH	BOLT CIRCLE BY BOLT SIZE			SLOT WIDTH	O-RINGS				
											SHAFT	ROTARY	STATIONARY	LOCK RING	
							A	B MAX	C MIN		C MAX	D MAX	E MIN	F MAX	G MIN
									8 mm	10 mm	12 mm				
35	114	60	62	56	40	54	85	88		14	126	134	135	130	
38	127	63	68	59	40	54	90	93		14	128	136	137	132	
60	165	86	97	82	40	54	118	121	124	17	142	150	151	146	
								12 mm	16 mm	20 mm					
65	199	102	116	98	52	63	140	143		17	231	237	238	151	
70	202	108	119	101	52	63	144	147		17	232	238	239	152	
75	208	114	125	107	52	63	151	154		17	234	240	241	153	
80	211	117	129	110	52	63	153	156	159	21	235	241	242	153	
85	216	124	135	117	52	63	160	164	167	21	237	243	244	154	
90	225	130	141	123	52	63	166	169	172	21	239	245	246	155	
95	228	133	144	126	52	63	169	172	176	21	240	246	247	156	
100	228	140	151	132	52	63	176	179	182	21	242	248	249	156	
110	241	149	160	142	52	63	185	188	191	21	245	251	252	158	
								20 mm	24 mm	30 mm					
120	279	171	162	83	104	104	227	230	236		351	359	361	253	
130	292	184	175	83	104	104	239	242	248		355	362	363	257	
140	298	191	181	83	104	104	246	249	255		357	363	364	259	
150	311	203	194	83	104	104	258	261	267		361	365	366	260	
160	323	216	207	83	104	104	271	274	280		363	367	368	262	
170	330	222	213	83	104	104	277	280	286		364	368	369	263	
180	342	235	226	83	104	104	290	293	299		366	370	371	265	
190	349	241	232	83	104	104	296	299	305		367	371	372	266	
200	361	254	245	83	104	104	309	312	318		369	373	-374	268	

## 280 MIXER JUMBO DIMENSIONAL DATA (INCH)

DASH NO.	SHAFT SIZE	GLAND OD	STUFFING BOX BORE	IB SEAL DIA	SB DEPTH	OB LENGTH	BOLT CIRCLE BY BOLT SIZE			O-RINGS			
							G MIN			SHAFT V	ROTARY W	STATIONARY X	LOCK RING Y
							7/8"	1"	1 1/8"				
-66	8.25	18.01	11.50	11.01	4.29	5.72	14.50	14.63	14.75	446	449	450	374
-68	8.50	18.01	11.50	11.01	4.29	5.72	14.50	14.63	14.75	446	449	450	374
-70	8.75	18.51	12.00	11.51	4.29	5.72	15.00	15.13	15.25	447	450	451	376
-72	9.00	18.51	12.00	11.51	4.29	5.72	15.00	15.13	15.25	447	450	451	376
-74	9.25	19.01	12.50	12.01	4.29	5.72	15.50	15.63	15.75	448	451	452	378
-76	9.50	19.01	12.50	12.01	4.29	5.72	15.50	15.63	15.75	448	451	452	378
-78	9.75	19.51	13.00	12.51	4.29	5.72	16.00	16.13	16.25	449	452	453	379
-80	10.00	19.51	13.00	12.51	4.29	5.72	16.00	16.13	16.25	449	452	453	379
-82	10.25	20.01	13.50	13.01	4.29	5.72	16.50	16.63	16.75	450	453	454	380
-84	10.50	20.01	13.50	13.01	4.29	5.72	16.50	16.63	16.75	450	453	454	380
-86	10.75	20.51	14.00	13.51	4.29	5.72	17.00	17.13	17.25	451	454	455	381
-88	11.00	20.51	14.00	13.51	4.29	5.72	17.00	17.13	17.25	451	454	455	381
-90	11.25	21.01	14.50	14.01	4.29	5.72	17.50	17.63	17.75	452	455	456	5-902
-92	11.50	21.01	14.50	14.01	4.29	5.72	17.50	17.63	17.75	452	455	456	5-902
-94	11.75	21.51	15.00	14.51	4.29	5.72	18.00	18.13	18.25	453	456	457	382
-96	12.00	21.51	15.00	14.51	4.29	5.72	18.00	18.13	18.25	453	456	457	382

## 280 MIXER JUMBO DIMENSIONAL DATA (METRIC)

SHAFT SIZE	OD	STUFFING BOX BORE	IB SEAL DIA	SB DEPTH	OB LENGTH	BOLT CIRCLE BY BOLT SIZE			O-RINGS			
						G MIN			SHAFT V	ROTARY W	STATIONARY X	LOCK RING Y
						20 mm	24 mm	30 mm				
210	457	292	280	109	145	368	372	378	446	449	450	374
220	470	305	292	109	145	381	385	391	447	450	451	376
230	470	305	292	109	145	381	385	391	447	450	451	376
240	483	318	305	109	145	394	398	404	448	451	452	378
250	496	330	318	109	145	406	410	417	449	452	453	379
260	508	343	330	109	145	419	423	429	450	453	454	380
270	521	356	343	109	145	432	436	442	451	454	455	381
280	521	356	343	109	145	432	436	442	451	454	455	381
290	534	368	356	109	145	445	449	455	452	455	456	5-902
300	546	381	369	109	145	457	461	467	453	456	457	382

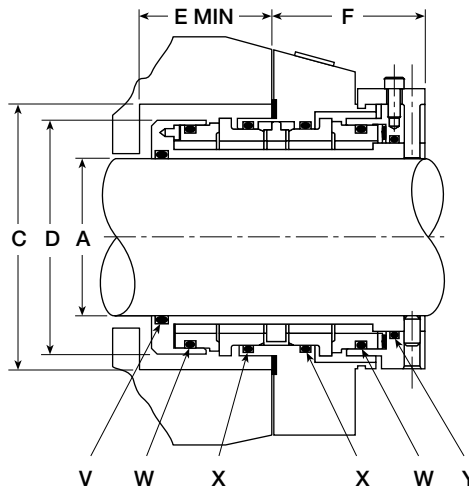
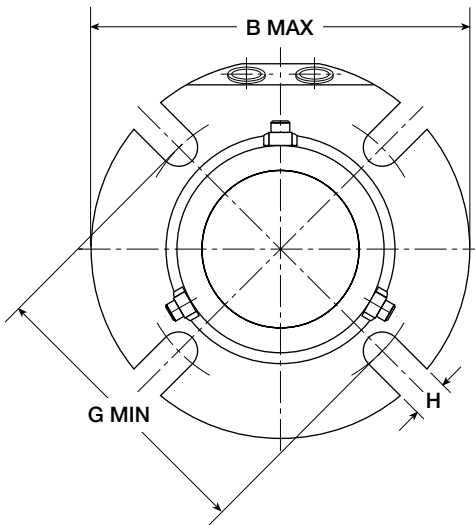

### KEY

- A - Shaft Size
- B - Maximum Gland Diameter
- C - Stuffing Box Inside Diameter
- D - Seal Diameter in Stuffing Box
- E - Minimum Stuffing Box Depth
- F - Outboard Seal Length
- G - Minimum Bolt Circle by Bolt Size
- H - Slot Width
- V - Shaft O-Ring
- W - Rotary O-Ring
- X - Stationary O-Ring
- Y - Lock Ring O-Ring

280 is a trademark of A.W. Chesterton Company

## A.W. CHESTERTON CO.

Middlesex Industrial Park, 225 Fallon Road  
 Stoneham, Massachusetts 02180-9101 USA  
 Telephone: 781-438-7000  
 Fax: 781-438-8971  
 www.chesterton.com

© A.W. CHESTERTON CO., 2000. All rights reserved.  
 Registered trademark owned and licensed by  
 A.W. CHESTERTON CO. in USA and other countries.

FORM NO. 072899 REV. 8

ISO 9001  
 CERTIFIED

PRINTED IN USA 8/01