

## DigesterPak™

Chesterton's Digester Packing Solution (DPS) combines the best characteristics of individual high-performance packing to bring you the highest reliability in digester sealing on new and older equipment.

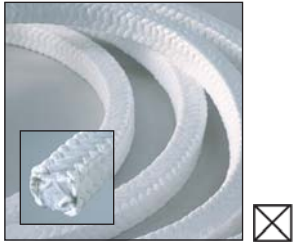

### Style 324 Super-Lon® Packing

Conforms to stuffing box irregularities and solidifies in place to create a tough close-tolerance anti-extrusion ring. Ideal for use in applications where excessive clearances exist.



### Style 477-1T PTFE Impregnated Carbon Yarn Packing

Provides a dense packing ring that transfers load effectively to the DigesterPak™ for reliable sealing.



### DigesterPak™ Carbon Reinforced PTFE/Graphite Packing

The DigesterPak™ combines a graphite coated PTFE braided packing with carbon reinforcement to provide outstanding resilience, long term sealing and superior leakage control.

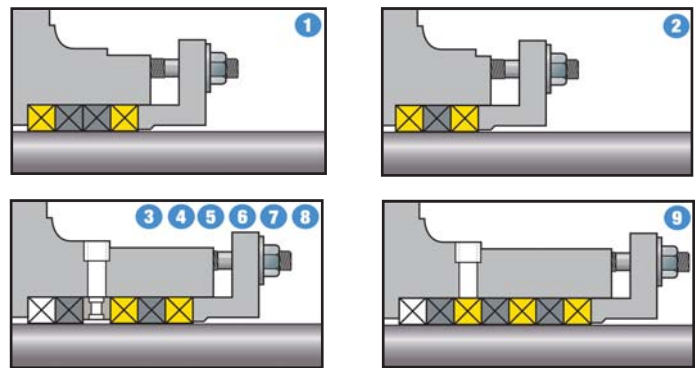
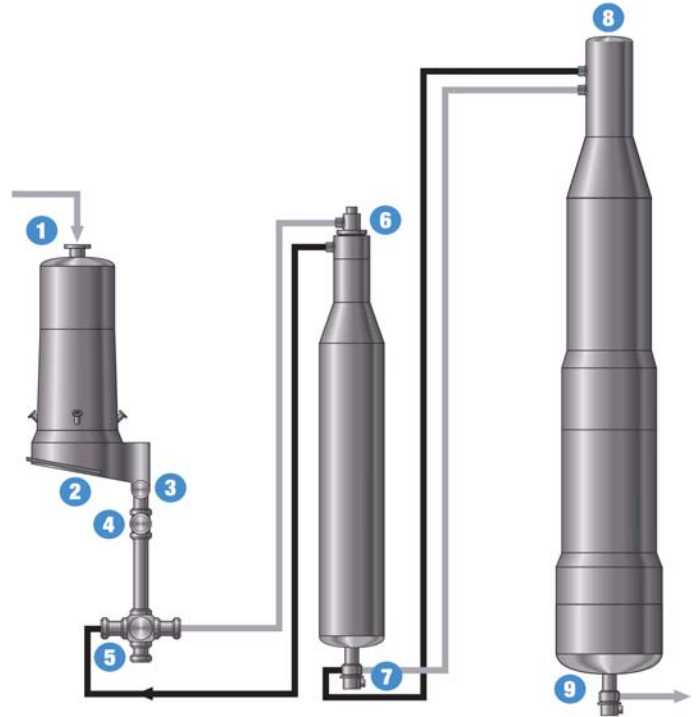

- |              |                                      |
|--------------|--------------------------------------|
| 1 Chip Bin   | 6 Impregnation Vessel Infeed Screw   |
| 2 Chip Meter | 7 Impregnation Vessel Bottom Scraper |
| 3 Junk Trap  | 8 Digester Top Separator             |
| 4 LP Feeder  | 9 Outlet Device                      |
| 5 HP Feeder  |                                      |

Technical Data reflects results of laboratory tests and is intended to indicate general characteristics only. A.W. CHESTERTON COMPANY DISCLAIMS ALL WARRANTIES EXPRESSED, OR IMPLIED, INCLUDING WARRANTIES OF MERCHANTABILITY AND FITNESS FOR A PARTICULAR PURPOSE OR USE. LIABILITY, IF ANY, IS LIMITED TO PRODUCT REPLACEMENT ONLY.