

# Yuzu™ Bassinet

M23401

 babyletto





hey there,

It's time to bring that dream nursery to life with babyletto.

We are here to help with all the tools and resources you need to design a space that feels like you.

Our babyletto community is important to us so we're always sharing styling tips, ideas to try, and unique inspiration.

Share your style with us at #babyletto



Welcome to the babyletto family

hola,

Ha llegado el momento de crear ese cuarto de bebé soñado gracias a babyletto.

Estamos aquí para ayudar con todas las herramientas y los recursos necesarios para diseñar un espacio adaptado a ti.

Valoramos la importancia de nuestra comunidad babyletto por eso siempre estamos compartiendo consejos de decoración, ideas para probar y una inspiración única.

Comparte tu estilo con nosotros en #babyletto



Te damos la bienvenida a la familia babyletto

bonjour,

Le temps est venu de créer la chambre de bébé de vos rêves avec babyletto.

Nous sommes ici pour vous aider en vous procurant tous les outils et les ressources dont vous avez besoin pour concevoir un espace qui vous correspond.

Nous accordons une grande importance à la communauté babyletto. Nous veillons à toujours partager des conseils de style, des idées à essayer et des inspirations uniques.

Partagez votre style avec nous en utilisant le mot-clic #babyletto



Bienvenue dans la famille babyletto

getting  
started

para  
comenzar

pour  
commencer

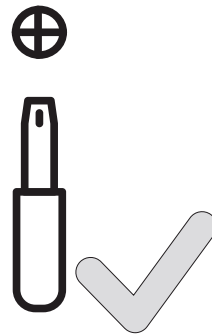
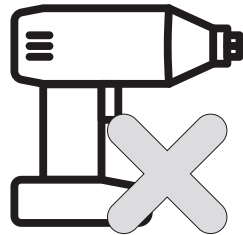
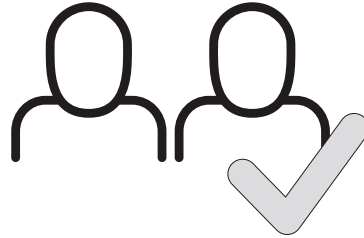
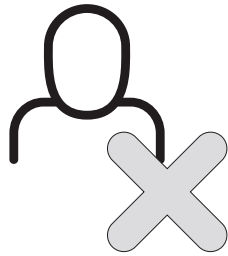

If you need help or have questions, please let us know!

Si necesita ayuda o si tiene preguntas, ¡no deje de contactarnos!

Si vous avez besoin d'aide ou avez des questions, n'hésitez pas à nous le faire savoir!

[BABYLETTO.COM/SUPPORT](https://www.babyletto.com/support)

(323) 282-5163

parts

not to scale

piezas

no a escala

pièces

non dessinées à l'échelle

(for bassinet • para moisés • pour berceau)

A  
x2

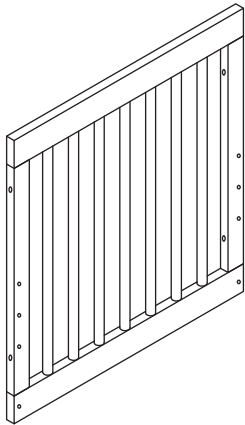

SIDE PANEL  
PANEL LATERAL  
PANNEAU LATÉRAL

C  
x2

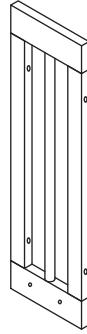

SMALL LEFT SIDE PANEL  
PANEL LATERAL IZQUIERDO PEQUEÑO  
PETIT PANNEAU LATÉRAL GAUCHE

D  
x2

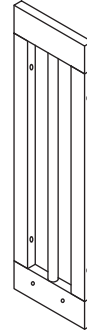

SMALL RIGHT SIDE PANEL  
PANEL LATERAL DERECHO PEQUEÑO  
PETIT PANNEAU LATÉRAL DROIT

E  
x2

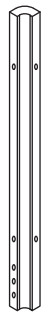

LEFT POST  
PIE IZQUIERDO  
PIED GAUCHE

F  
x2

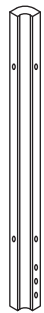

RIGHT POST  
PIE DERECHO  
PIED DROIT

G  
x2

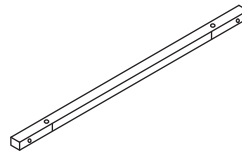

SHORT BASE SUPPORT BAR I  
BARRA I DE SOPORTE BASE CORTA  
BARRE I DE SUPPORT À BASE COURTE

N

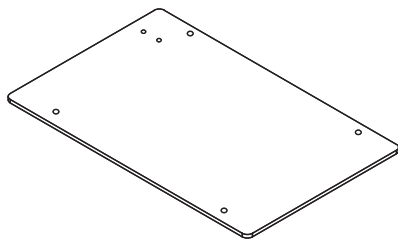

BASSINET BOTTOM BOARD  
TABLERO INFERIOR DE CUNA  
PANNEAU DE FOND BERCEAU

P

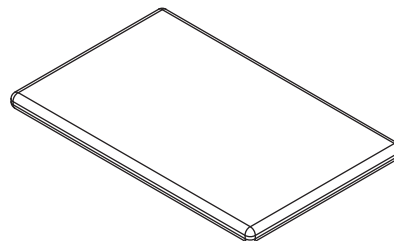

BASSINET PAD  
ALMOHADILLA DE CUNA  
COUSSIN BERCEAU

**hardware**  
actual size

**herraje**  
tamaño real

**matériel**  
taille actuelle

(for bassinet • para moisés • pour berceau)

**H2**

x4

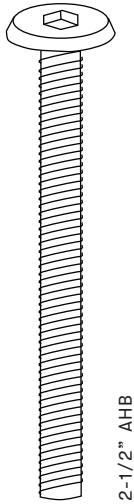

**H3**

x16

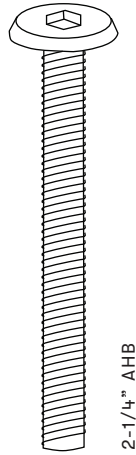

**H5**

x4

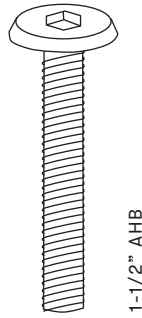

**H6**

x4

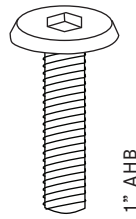

**H9**

x28



**H11**

x4

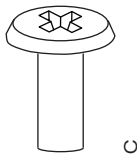

**H12**

x4

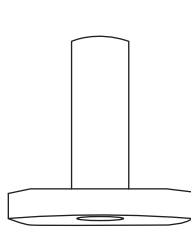

**H13**

x1

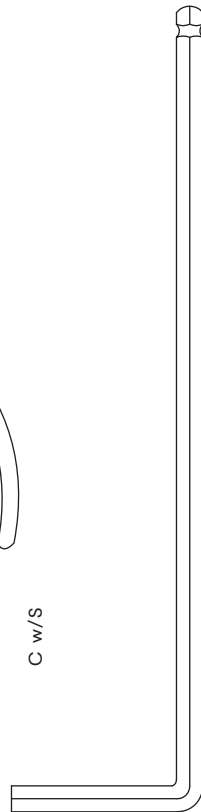

AWR

\* KEEP THE ALLEN WRENCH FOR FUTURE USE.  
\* GUARDE LA LLAVE ALLEN PARA USO FUTURO.  
\* CONSERVER LA CLÉ ALLEN POUR UN USAGE ULTÉRIEUR.

assembly  
instructions

instrucciones  
de ensamblaje

instructions  
de montage

1

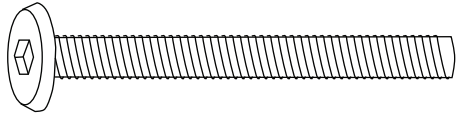

H3  
x8



H9  
x8

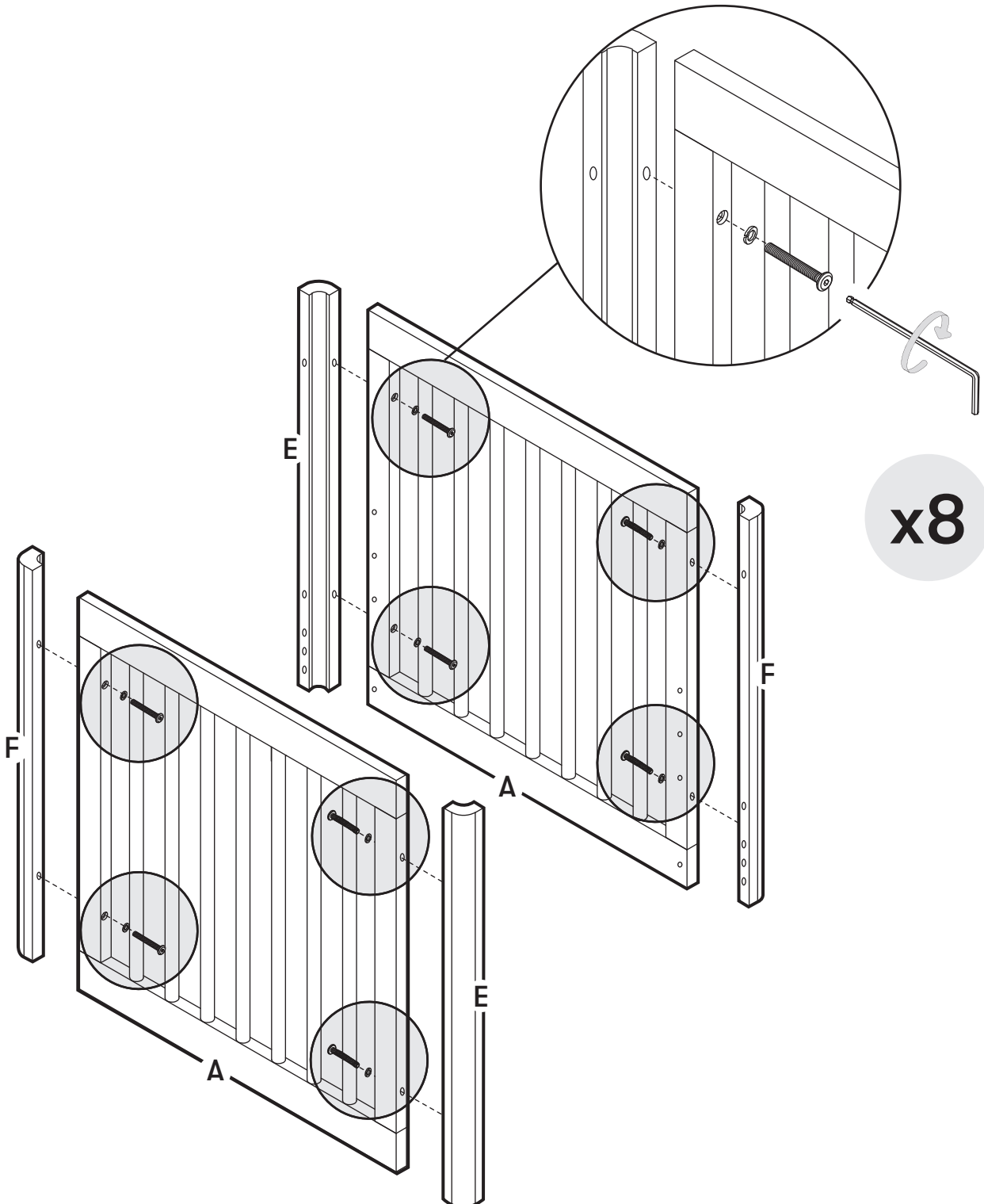

2

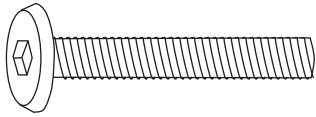

H5  
x4



H9  
x4

\* Choose a high position for your infant and lower the bottom board and support bars as your child grows.

\* Elegir una posición alta para el bebé y bajar el tablero inferior y las barras de apoyo a medida que vaya creciendo el niño.

\* Choisir la position supérieure pour l'enfant puis abaisser le panneau de fond et les supports au fur et à mesure de sa croissance.

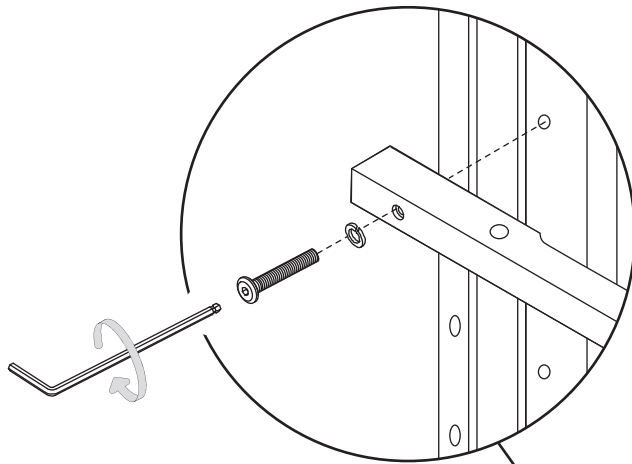

x4

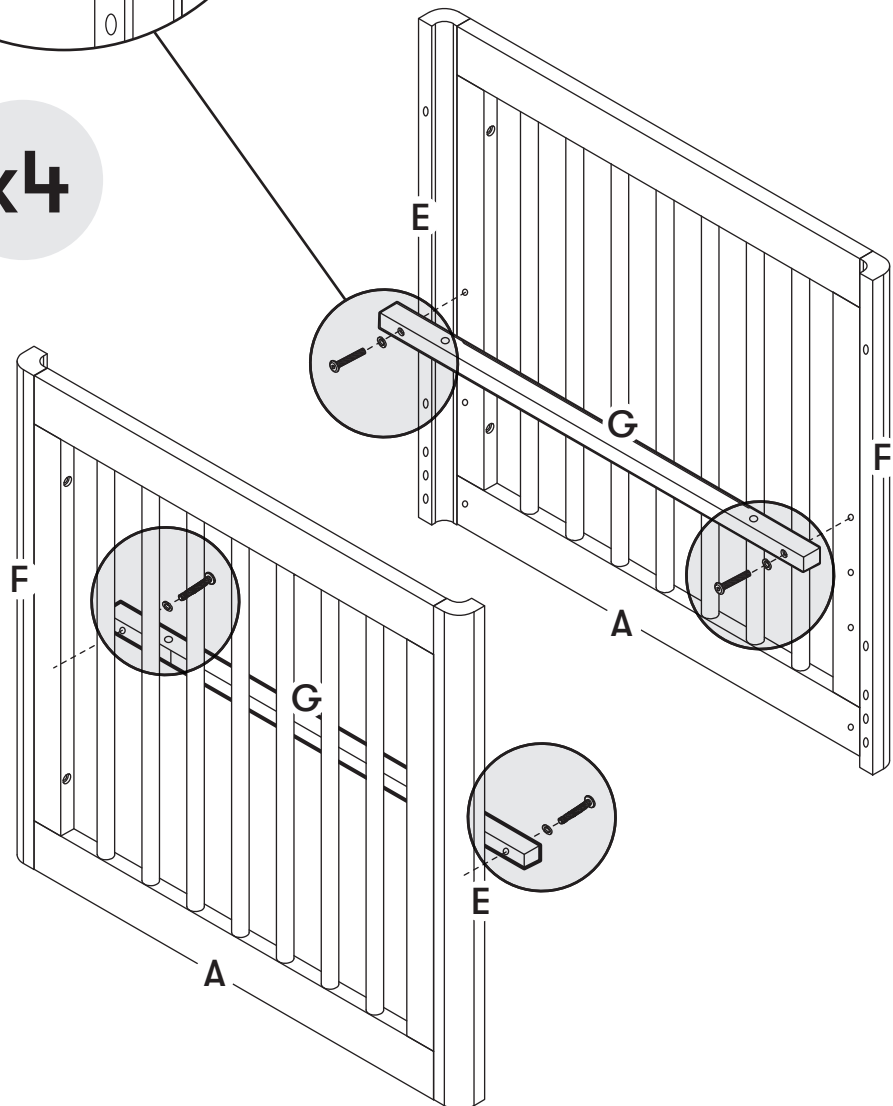



3

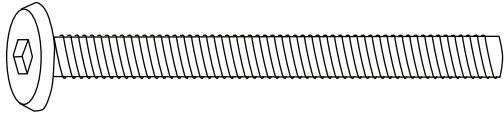

H2  
x4



H9  
x4

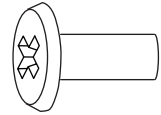

H11  
x4

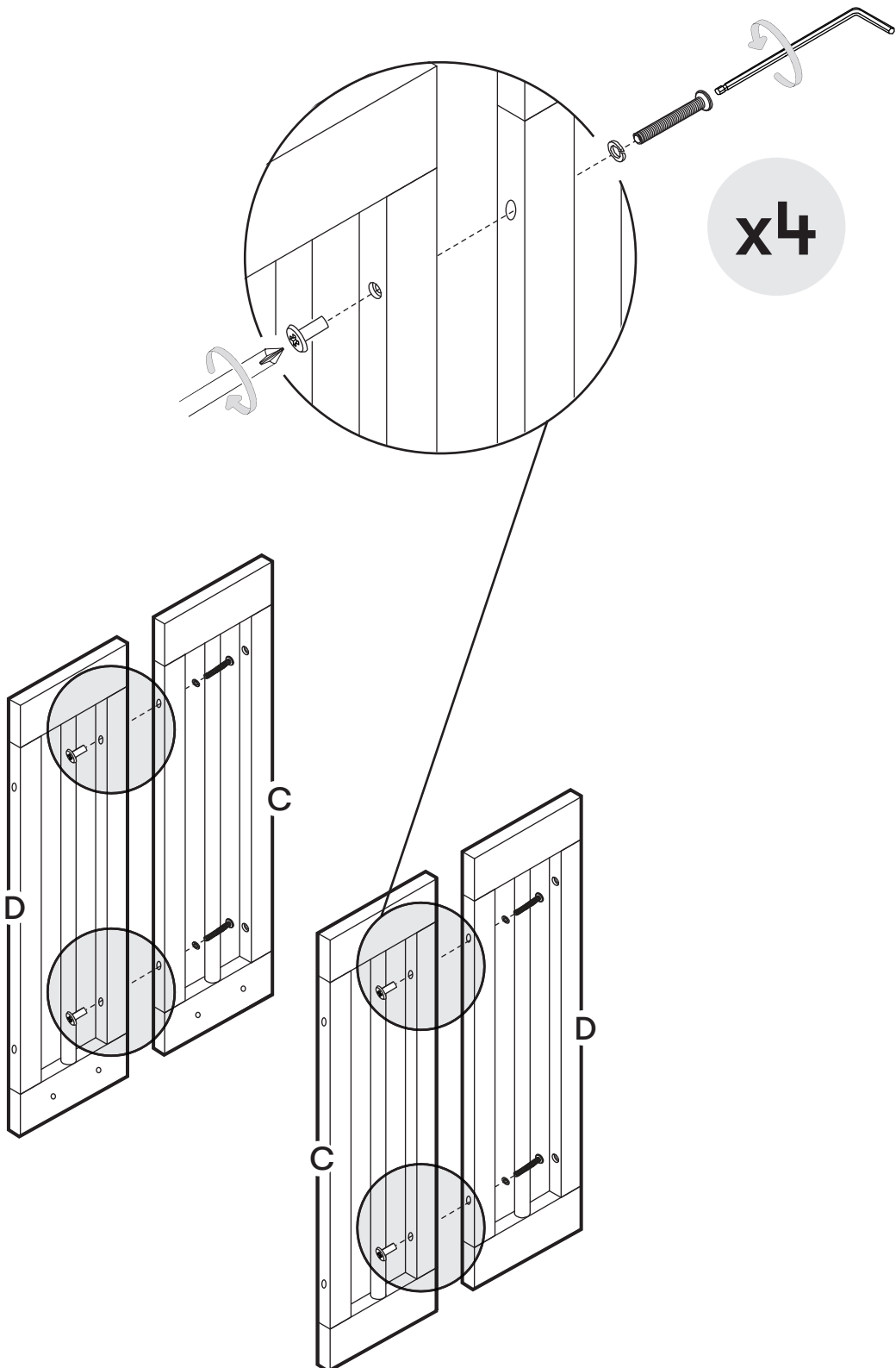

4

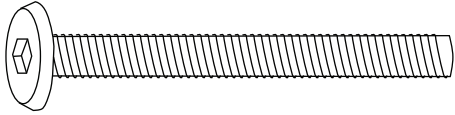

H3  
x4



H9  
x4

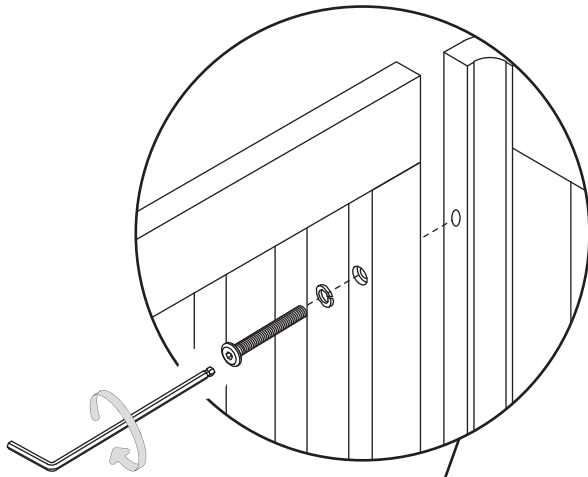

x4

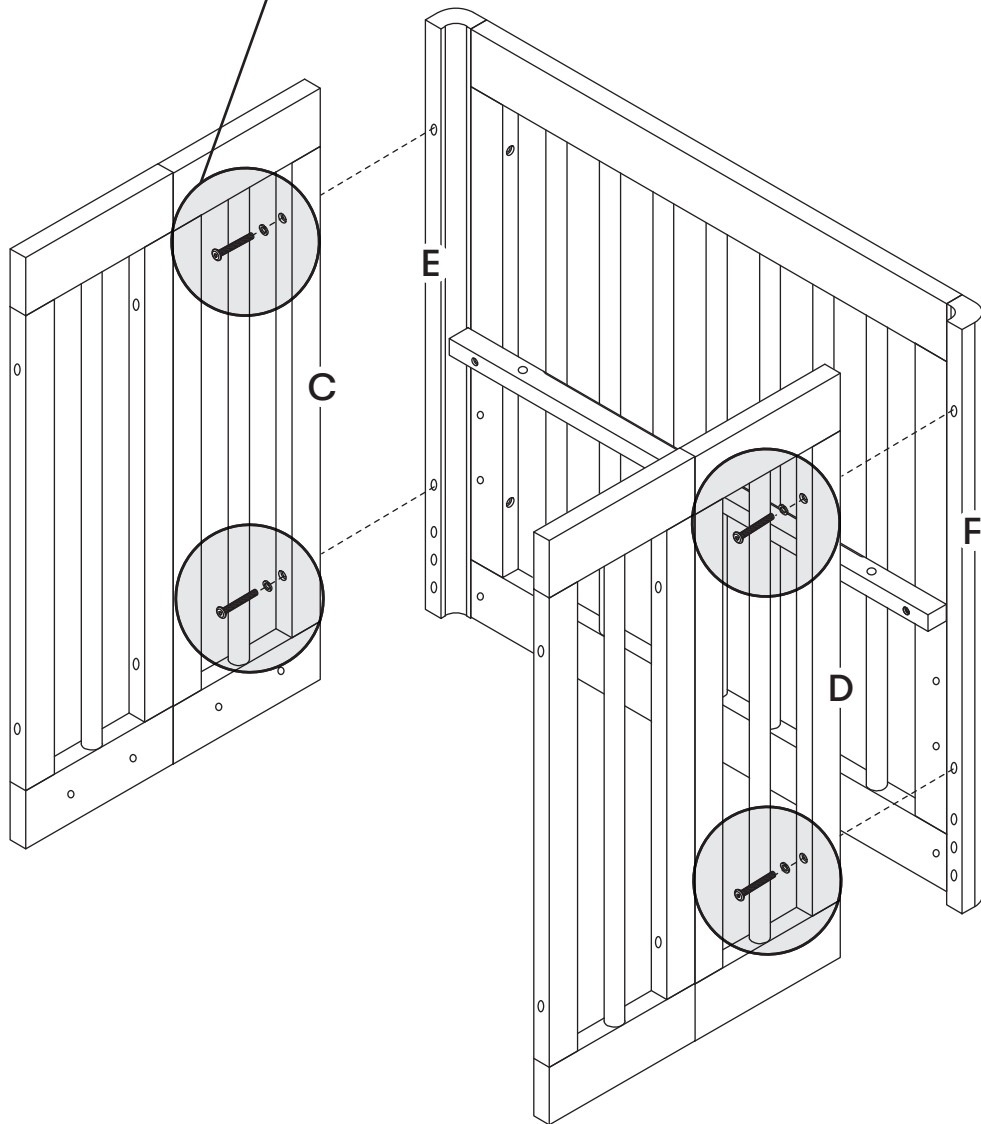

5

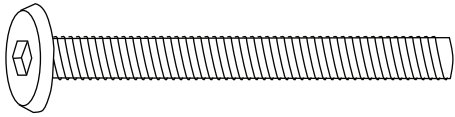

H3  
x4



H9  
x4

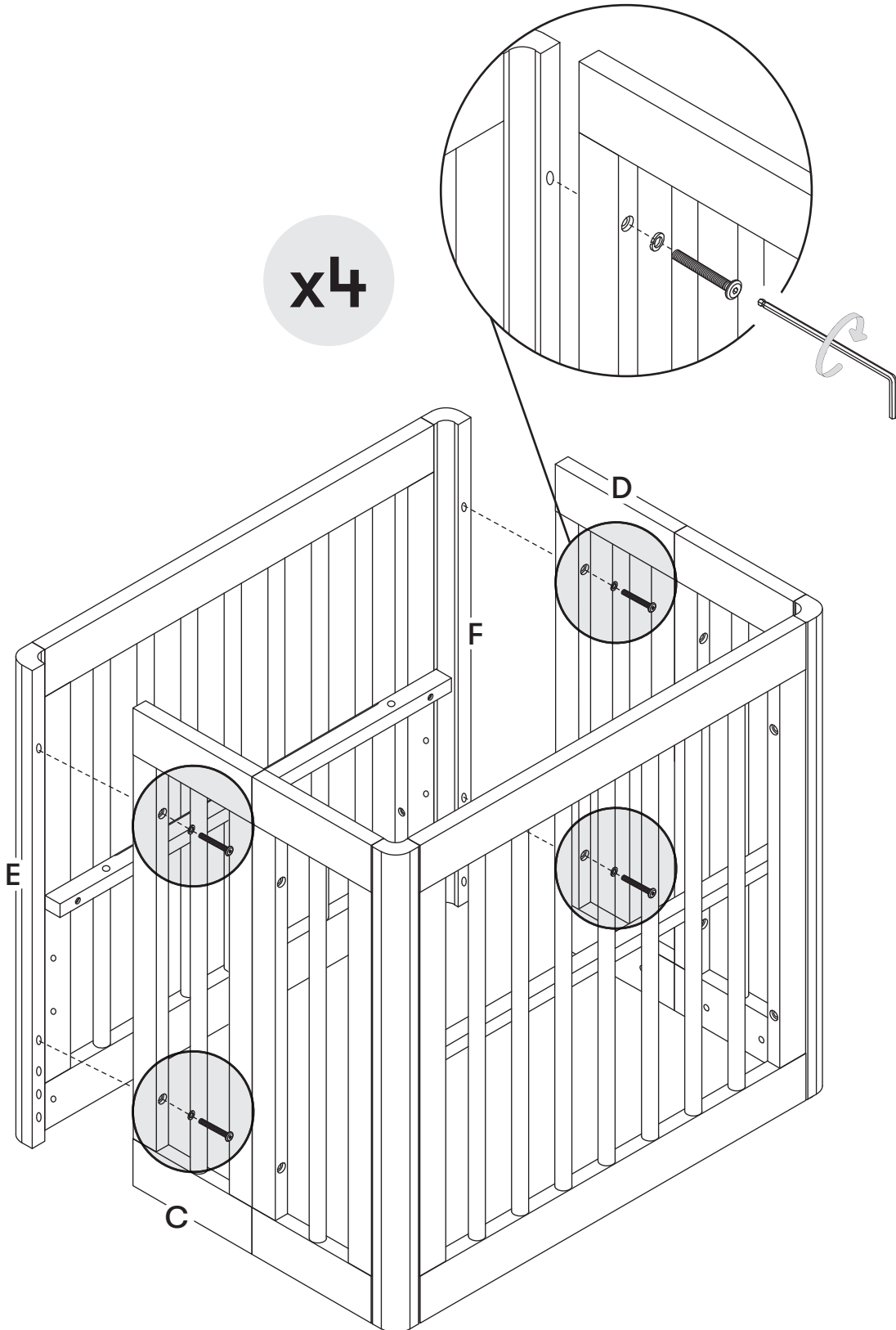

6

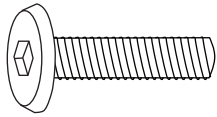

H6  
x4



H9  
x4

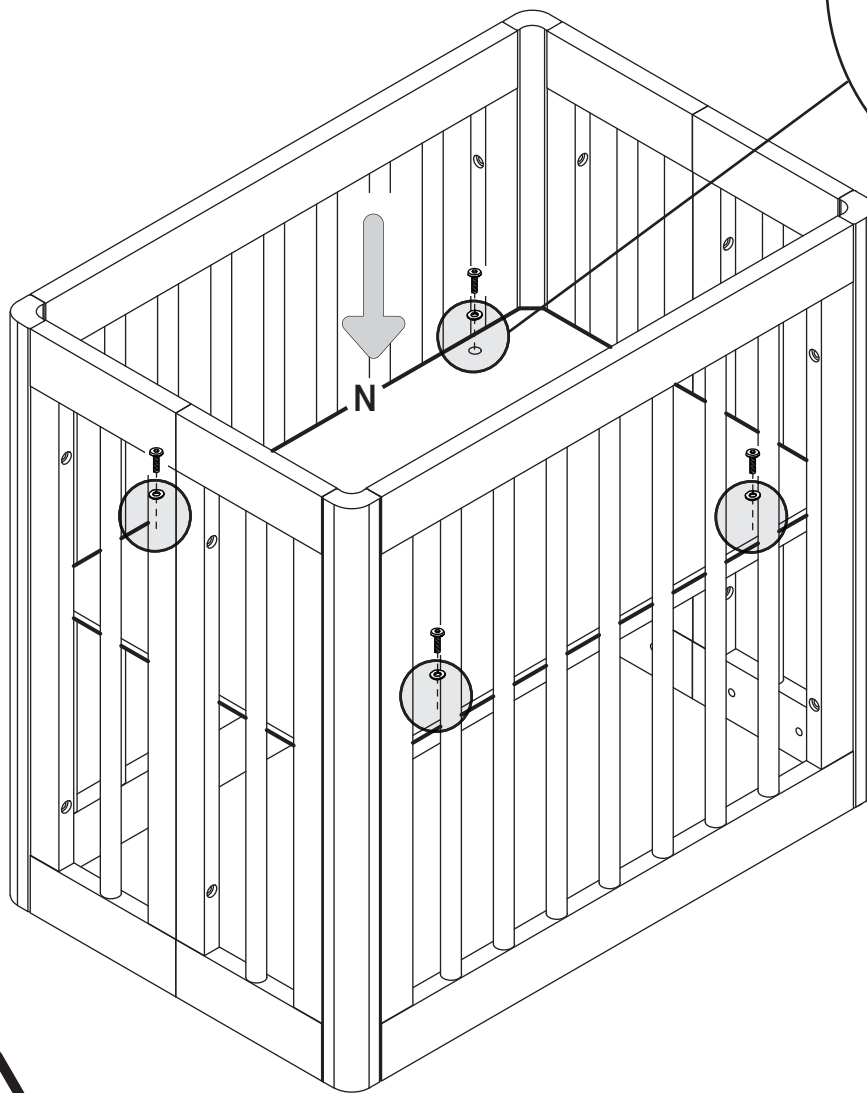
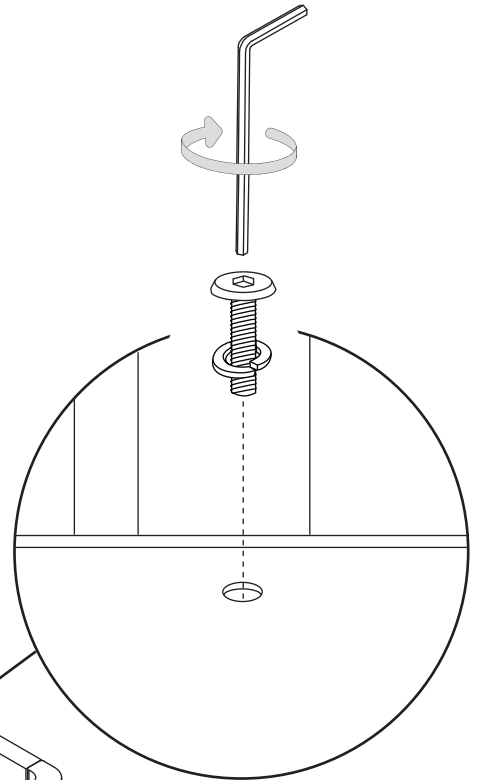

x4

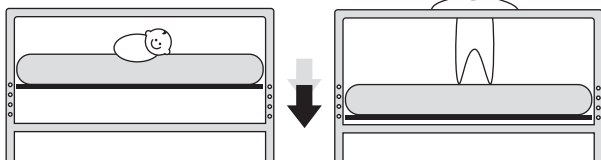

Lower the support as your child grows.

Baje el soporte a medida que vaya creciendo el niño.

Abaissez le support à mesure que votre enfant grandit.

7

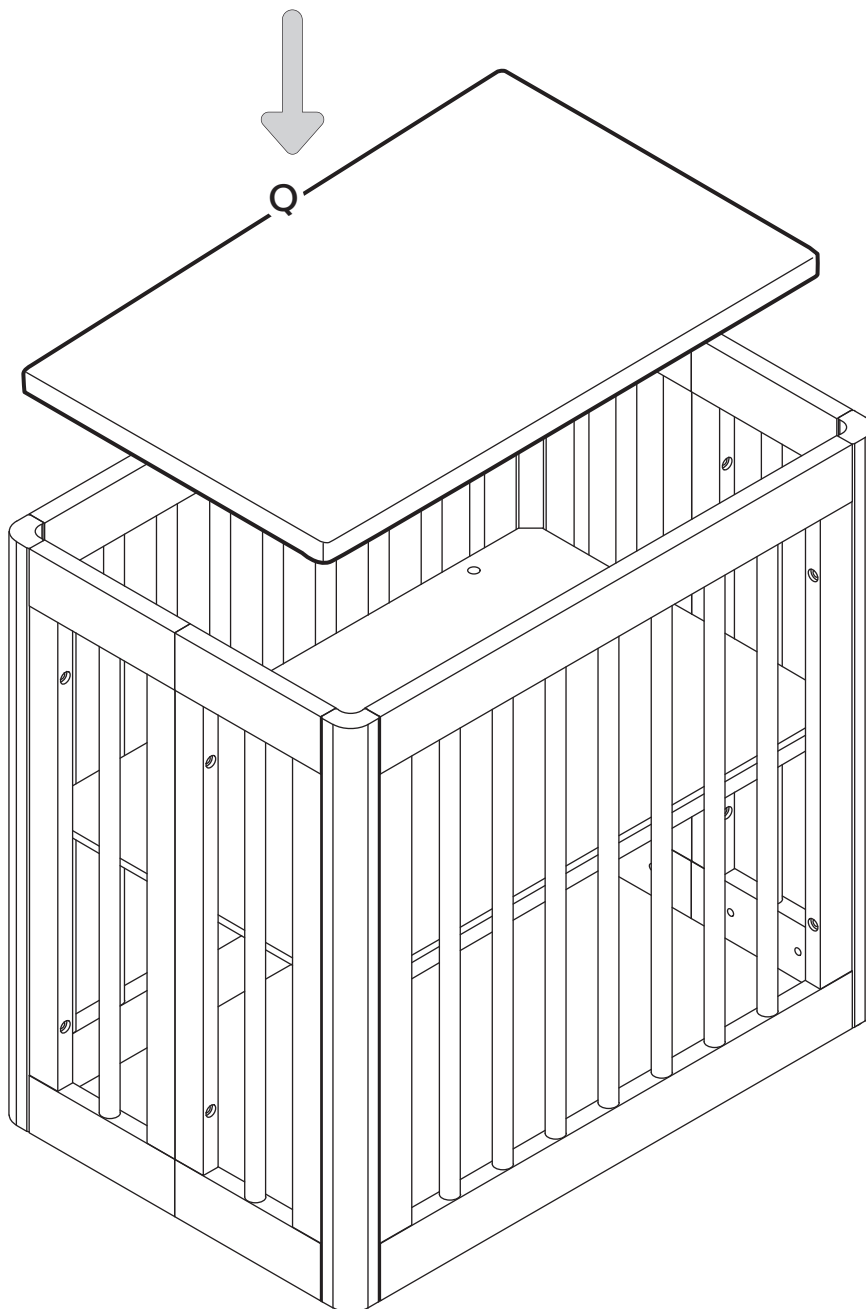

8

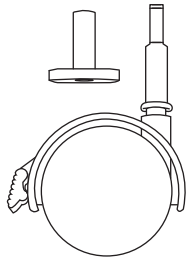

H12  
x4

**Optional / Opcional / En option :**

- \* Tighten firmly until the casters snap into place.  
Be sure the casters can turn freely.
- \* Apretar firmemente hasta que las ruedas encajen con un chasquido en su lugar.  
Revisar que las ruedas puedan girar libremente.
- \* Qu'ils de ce jusqu'à de fermeture d'appuyer rentrer de jeu de caractères. Être sur que les casters peut tourner librement.

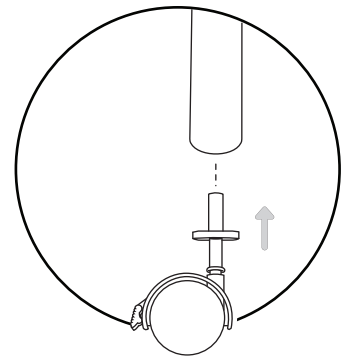
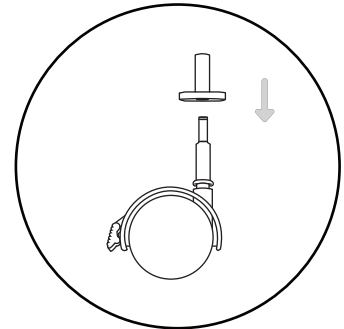

x4

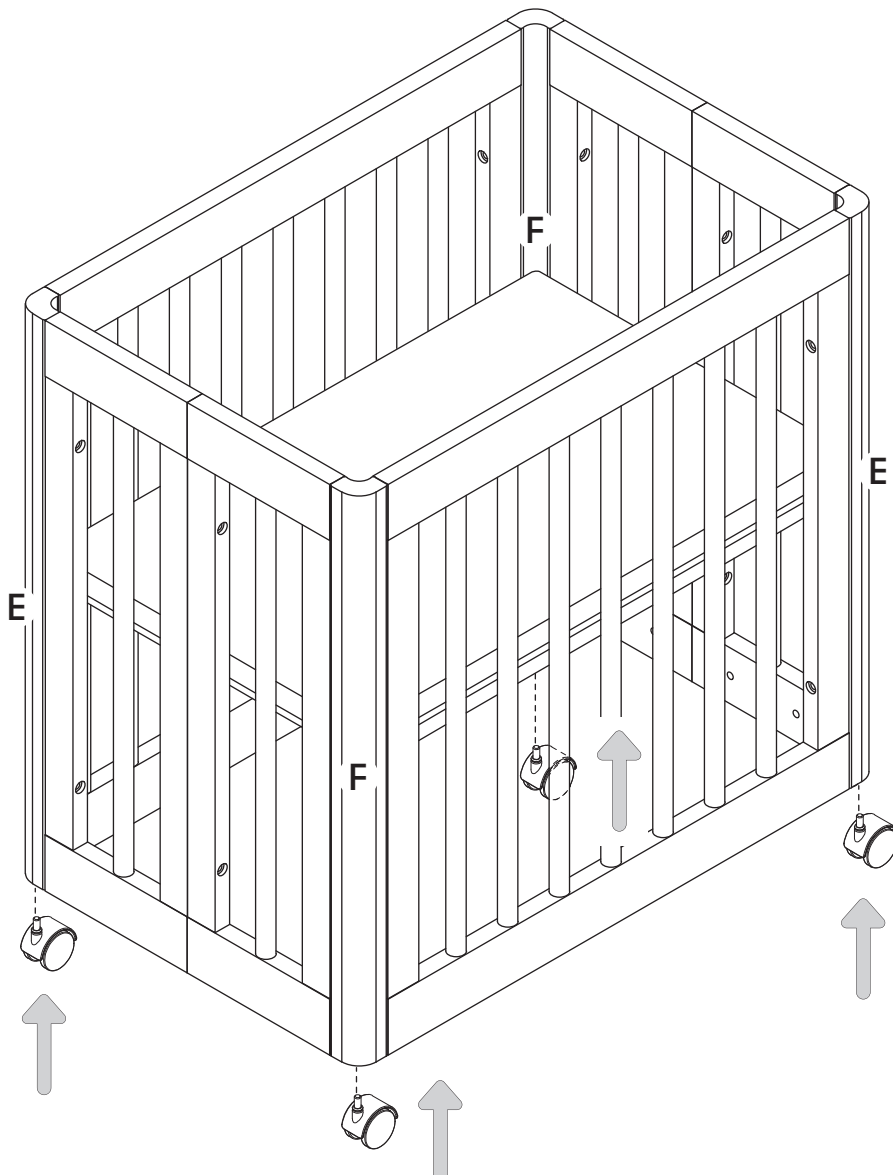

*Voilà!*

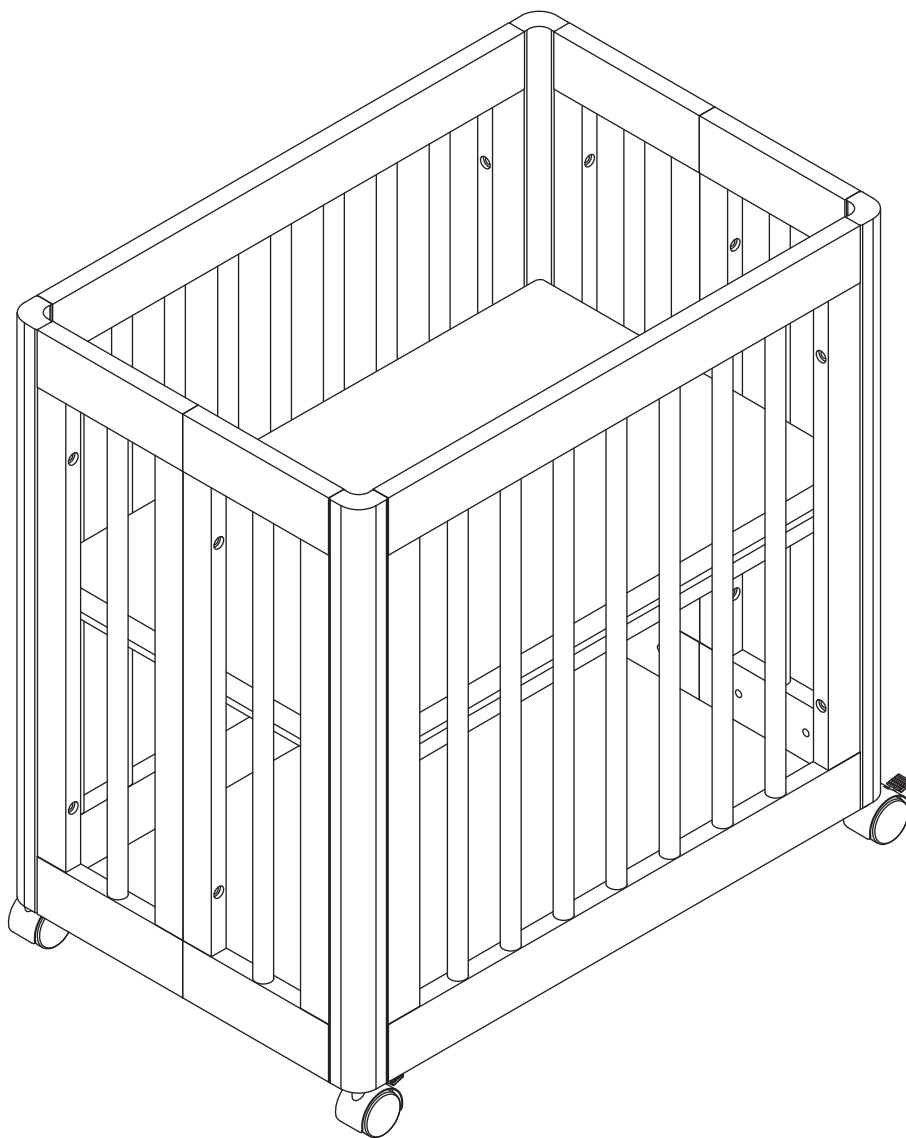

## WARNING

**STOP USING THE BASSINET/CRADLE WHEN A CHILD IS ABLE TO SIT, STAND, KNEEL OR ROLL OVER ON HIS/HER OWN. THE BASSINET/CRADLE COULD TIP OVER IF THE CHILD IS LEANING AGAINST THE RAILS OF THE BASSINET/CRADLE.**

**FAILURE TO FOLLOW THESE WARNINGS AND THE INSTRUCTIONS COULD RESULT IN SERIOUS INJURY OR DEATH.**

### **SUFFOCATION HAZARD**

Use only the pad provided by manufacturer. Infants have suffocated:

- In gaps between extra padding and side of the bassinet/cradle
- On soft bedding

### **FALL HAZARD**

To help prevent falls, do not use this product when the infant begins to push up on hands and knees or has reached manufacturer's recommended maximum weight 17.5 lbs (7.9 kg), whichever comes first.

Always check that the bassinet is securely locked on the base/stand by pulling upwards on the bassinet bed.

Do not use this bassinet if you cannot exactly follow the instructions that come with it. Do not use this bassinet for a child who can roll over or who has reached 17.5 lbs (7.9 kg). Use only the pad provided by manufacturer. NEVER add a pillow, comforter, or another mattress for padding. To reduce the risk of SIDS, pediatricians recommend healthy infants be placed on their backs to sleep, unless otherwise advised by your physician.

If a sheet is used with the pad, use only the one provided by the bassinet or cradle manufacturer or one specifically designed to fit the dimensions of the bassinet or cradle mattress.

Strings can cause strangulation! Do not place items with a string around a child's neck, such as hood strings or pacifier cords. Do not suspend strings over a bassinet or cradle or attach strings to toys.

Do not place this bassinet near a window or a patio door where a child could reach the cord of a blind or curtain and be strangled.

Check this bassinet regularly before using it and do not use it if any parts are loose or missing or if there are any signs of damage. Do not substitute parts. Contact the manufacturer if replacement parts or additional instructions are needed.

## **CAUTION**

**THE RECOMMENDED MAXIMUM WEIGHT OF THE OCCUPANT IS 17.5 LBS (7.9 kg). PLEASE READ THE CAUTION AND WARNING STATEMENTS INSERT BEFORE USING YOUR CRADLE.**



## **⚠️ ADVERTENCIA:**

**DEJE DE USAR EL MOISÉS/CUNA CUANDO EL NIÑO PUEDA SENTARSE, PARARSE, ARRODILLARSE O DARSE VUELTA SIN AYUDA. EL MOISÉS/CUNA PODRÍA VOLCARSE SI EL NIÑO SE APOYA CONTRA LAS BARANDAS DEL MOISÉS/CUNA.**

**SI NO SE SIGUEN ESTAS ADVERTENCIAS Y LAS INSTRUCCIONES PODRÍA OCASIONAR LESIONES GRAVES O FATALES.**

### **PELIGRO DE ASFIXIA**

Use solo la colchoneta provista por el fabricante.

Los bebés se han asfixiado:

- En los huecos entre el acolchado adicional y el costado del moisés/cuna
- Sobre la ropa de cama blanda

### **PELIGRO DE CAÍDA**

Para ayudar a prevenir caídas, no use este producto cuando el niño comience a levantarse apoyándose con las manos y las rodillas o haya llegado al peso máximo de 7.9 kg (17.5 lbs) recomendado por el fabricante, lo que ocurra primero.

Siempre compruebe que el moisés esté firmemente trabado en la base tratando de levantar la cama del moisés.

No use este moisés si no puede seguir exactamente las instrucciones incluidas.

No use este moisés para un niño que pueda darse vuelta o que haya llegado a pesar 7.9 kg (17.5 lbs).

Use solo la colchoneta provista por el fabricante.

NUNCA agregue una almohada, edredón ni otro colchón para aumentar el acolchado.

Para reducir el riesgo del síndrome de muerte infantil súbita (SMIS), los pediatras recomiendan poner a los bebés sanos boca arriba para dormir, a menos que su médico le indique otras instrucciones.

Si se usa una sábana con la colchoneta, use solo la que entrega el fabricante del moisés o cuna o una que sea diseñada específicamente para adecuarse a las dimensiones del colchón del moisés o cuna.

¡Las cuerdas pueden causar estrangulación!

No ponga objetos que tengan cuerdas alrededor del cuello de un niño, como cordones de capuchas o de chupetes. No suspenda cuerdas encima de un moisés o cuna ni ponga cordeles en los juguetes.

No ponga este moisés cerca de una ventana o puerta ventana donde un niño pueda alcanzar el cordón de una cortina o persiana que pueda estrangularlo.

Revise este moisés regularmente antes de usarlo y no lo use si hay alguna pieza suelta o faltante o si tiene señales de daño.

No sustituya piezas. Póngase en contacto con el fabricante si necesita piezas de repuesto o instrucciones adicionales.

**PRECAUCIÓN  
EL PESO MÁXIMO RECOMENDADO DE QUIEN  
USE EL PRODUCTO ES DE 7.9 KGS (17.5 LB).  
LEA EL INSERTO DE PRECAUCIÓN Y LAS  
ADVERTENCIAS ANTES DE USAR LA CUNA.**

## **⚠️ AVERTISSEMENT:**

**CESSER L'UTILISATION DU BERCEAU DÈS QUE L'ENFANT EST CAPABLE DE S'ASSEOIR, DE SE LEVER, DE MARCHER À QUATRE PATTES OU DE SE RETOURNER TOUT SEUL. LE BERCEAU POURRAIT BASCULER SI L'ENFANT SE PENCHE CONTRE L'UN DES CÔTÉS DU BERCEAU.**

**LE NON-RESPECT DES AVERTISSEMENTS ET DIRECTIVES D'ASSEMBLAGE PEUT ENTRAÎNER DE GRAVES BLESSURES OU LA MORT.**

### **RISQUE DE SUFFOCATION**

Utiliser seulement le matelas fourni par le fabricant. Des bébés se sont étouffés :

- Dans les espaces entre le matelassage supplémentaire et le côté du lit de bébé/berceau.
- Sur des articles de literie mous.

### **RISQUE DE CHUTE**

Pour éviter les chutes, ne pas utiliser ce produit lorsque l'enfant commence à se soulever avec les mains et les genoux ou a atteint le poids maximum de 7,9 kg (17,5 lb), recommandé par le fabricant, selon ce qui advient en premier.

S'assurer que le lit de bébé est solidement fixé sur la base/le socle en tirant le lit de bébé vers le haut.

## **MISE EN GARDE**

**LE POIDS MAXIMUM RECOMMANDÉ DE L'OCCUPANT EST DE 7,9 KG (17,5 LB).  
PRIÈRE DE LIRE LE FEUILLET DE MISES EN GARDE ET D'AVERTISSEMENTS AVANT D'UTILISER CE BERCEAU.**

Ne pas utiliser ce moïse à moins d'être en mesure de suivre précisément les instructions qui l'accompagnent.

Ne pas utiliser ce moïse si l'enfant est capable de se retourner ou a atteint 7,9 kg (17,5 lb).

N'utiliser que le coussin fourni par le fabricant. NE JAMAIS ajouter un oreiller, un édredon ou un autre matelas.

Pour réduire les risques de SMSN, les pédiatres recommandent de placer les nourrissons en bonne santé sur le dos pour dormir, sauf indication contraire de votre médecin.

Si un drap est utilisé sur le coussin, n'utiliser que celui fourni par le fabricant du berceau ou du lit de bébé ou un drap spécialement conçu pour s'ajuster aux dimensions du matelas du berceau ou du lit de bébé.

Les cordons peuvent causer un étranglement! Ne placer aucun article muni d'un cordon autour du cou d'un enfant comme que les cordons d'un capuchon ou d'une sucette. Ne pas suspendre de ficelles au-dessus du berceau ou du lit de bébé, ni en attacher aux jouets.

Ne pas placer le moïse près d'une fenêtre ou d'une porte-fenêtre où l'enfant pourrait se saisir des cordes d'un store ou d'un rideau et s'étrangler.

Vérifier régulièrement le moïse préalablement à son utilisation et ne pas l'utiliser en cas de détection d'une pièce desserrée, de pièce manquante ou de tout signe de dommages.

Ne pas substituer une pièce à une autre.

Communiquer avec le fabricant pour obtenir, au besoin, une pièce de rechange ou des instructions supplémentaires.

Read all instructions BEFORE assembly and USE of product.  
KEEP INSTRUCTIONS FOR FUTURE USE.

Lea todas las instrucciones ANTES de armar y USAR el producto.  
CONSERVE LAS INSTRUCCIONES PARA USO FUTURO.

Lire toutes les instructions AVANT l'assemblage et D'UTILISER du lit.  
GARDER LE MANUEL POUR UN USAGE ULTERIEUR.

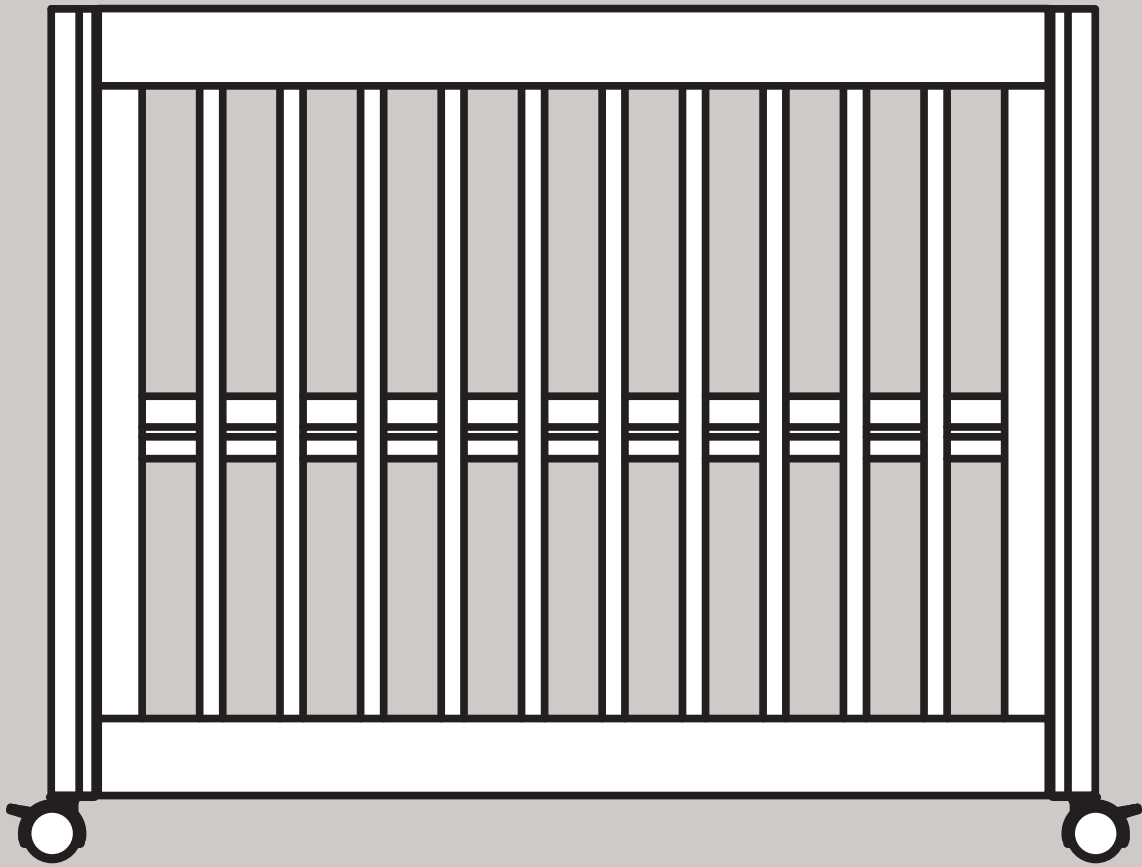

Yuzu™ Midi

M23401

 babyletto

parts

not to scale

piezas

no a escala

pièces

non dessinées à l'échelle

(for midi crib

para cuna midi

pour lit de bébé midi)

A  
x2

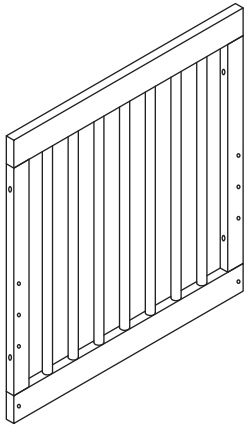

SIDE PANEL  
PANEL LATERAL  
PANNEAU LATÉRAL

B  
x2

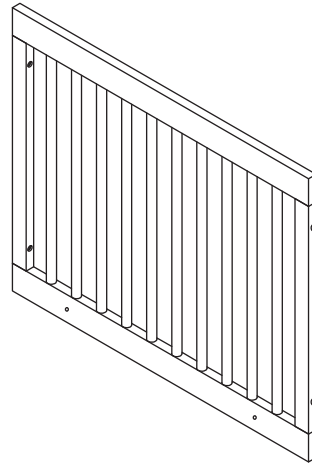

FRONT / BACK PANEL  
PANEL FRONTAL / POSTERIOR  
PANNEAU AVANT / ARRIÈRE

E  
x2



LEFT POST  
PIE IZQUIERDO  
PIED GAUCHE

F  
x2



RIGHT POST  
PIE DERECHO  
PIED DROIT

G  
x2

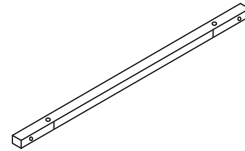

SHORT BASE SUPPORT BAR I  
BARRA I DE SOPORTE BASE CORTA  
BARRE I DE SUPPORT À BASE COURTE

H

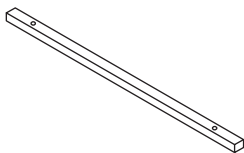

SHORT BASE SUPPORT BAR II  
BARRA II DE SOPORTE BASE CORTA  
BARRE II DE SUPPORT À BASE COURTE

I

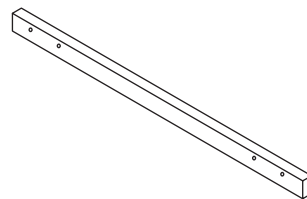

SHORT BASE SUPPORT BAR III  
BARRA III DE SOPORTE BASE CORTA  
BARRE III DE SUPPORT À BASE COURTE

O

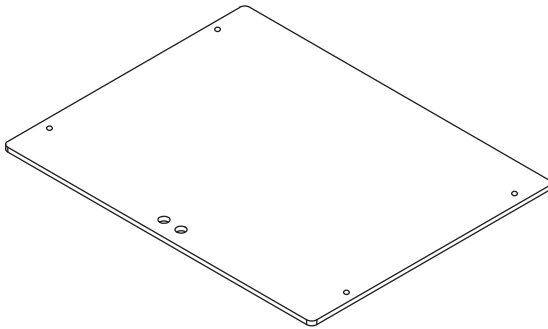

MIDI BOTTOM BOARD  
 TABLERO INFERIOR DE MIDI  
 PANNEAU DE FOND MIDI

Q

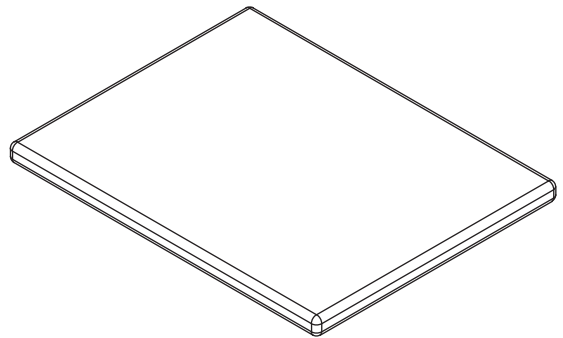

MIDI PAD  
 ALMOHADILLA DE MIDI  
 COUSSIN MIDI

for midi toddler bed conversion  
 para conversión de midi cama bebé que ya camina  
 pour conversion de lit midi pour tout-petit

C



SMALL LEFT SIDE PANEL  
 PANEL LATERAL IZQUIERDO PEQUEÑO  
 PETIT PANNEAU LATÉRAL GAUCHE

D

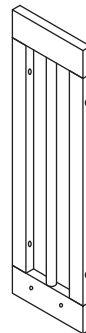

SMALL RIGHT SIDE PANEL  
 PANEL LATERAL DERECHO PEQUEÑO  
 PETIT PANNEAU LATÉRAL DROIT

for midi daybed conversion  
 para conversión de midi diván  
 pour la conversion en lit midi de jour

J

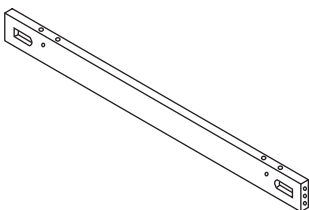

FRONT BOTTOM CROSS BAR  
 BARRA TRANSVERSAL DELANTERA INFERIOR  
 BARRE TRANSVERSALE INFÉRIEURE AVANT

**hardware**  
actual size

**herraje**  
tamaño real

**matériel**  
taille actuelle

(for midi crib para cuna midi pour lit de bébé midi)

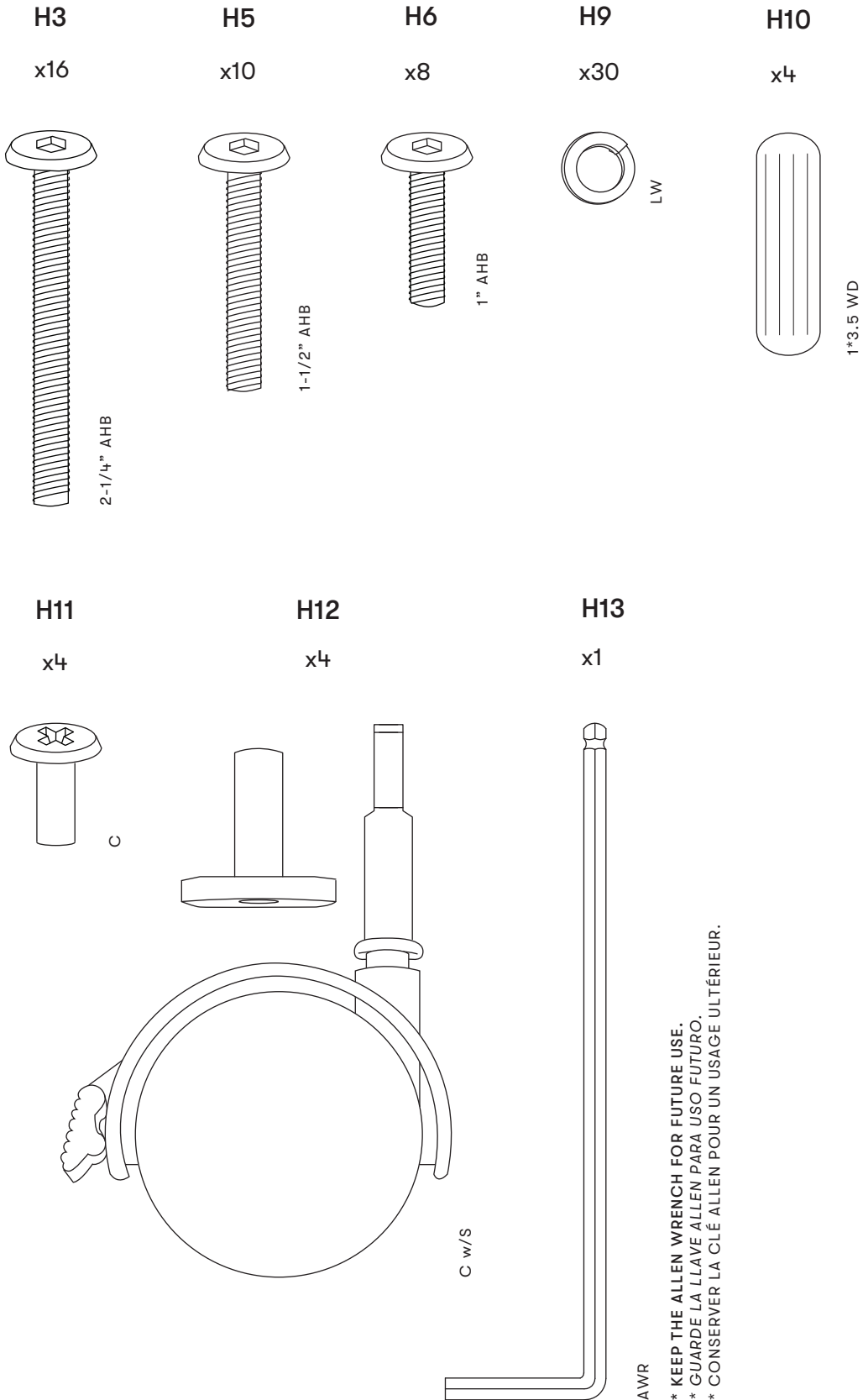

\* KEEP THE ALLEN WRENCH FOR FUTURE USE.  
\* GUARDE LA LLAVE ALLEN PARA USO FUTURO.  
\* CONSERVER LA CLÉ ALLEN POUR UN USAGE ULTÉRIEUR.

1

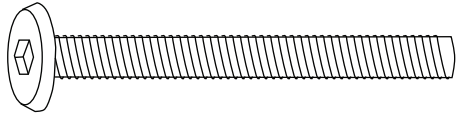

H3  
x8



H9  
x8

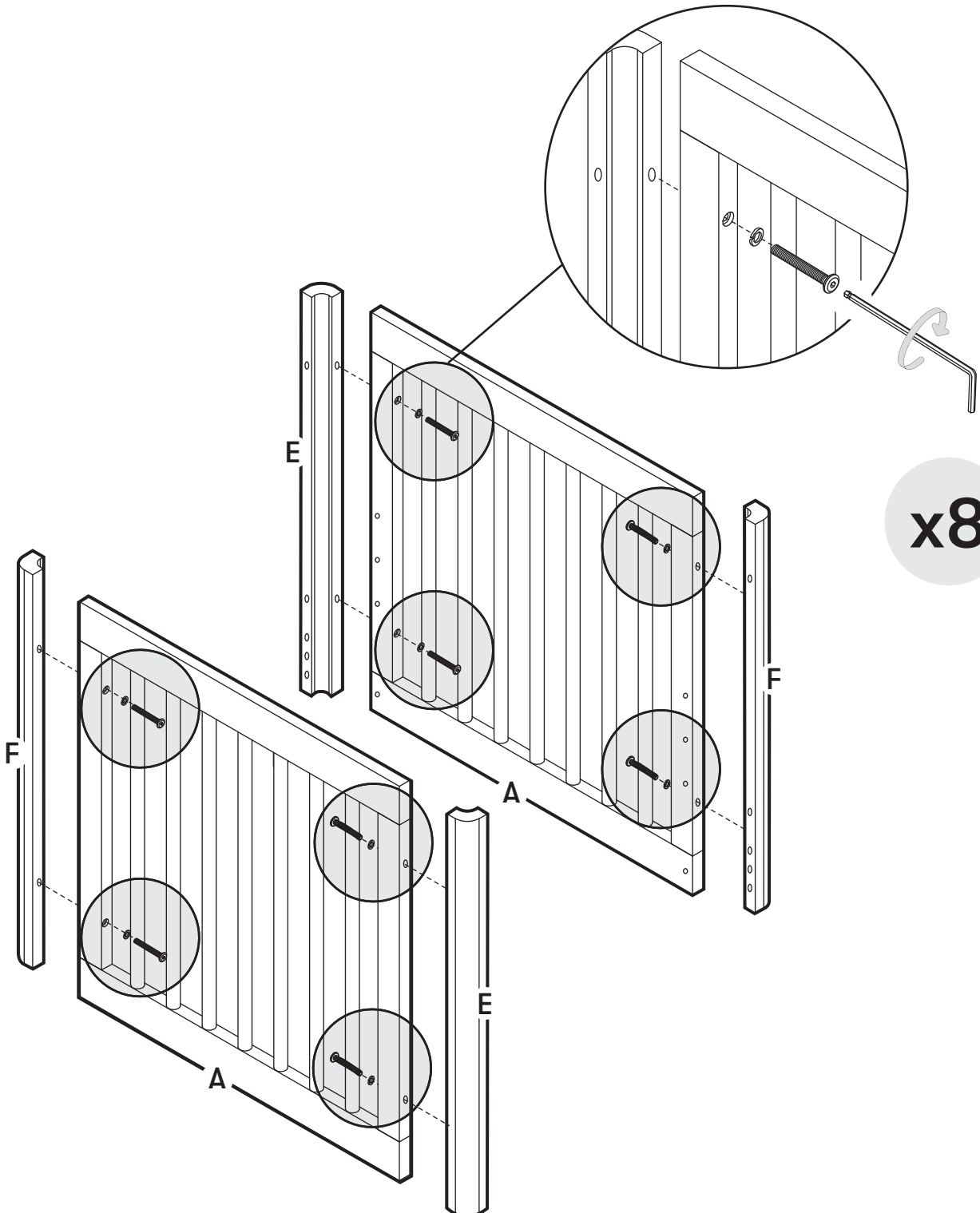

x8

2

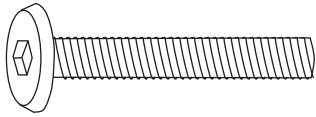

H5  
x4



H9  
x4

\* Choose a high position for your infant and lower the bottom board and support bars as your child grows.

\* Elegir una posición alta para el bebé y bajar el tablero inferior y las barras de apoyo a medida que vaya creciendo el niño.

\* Choisir la position supérieure pour l'enfant puis abaisser le panneau de fond et les supports au fur et à mesure de sa croissance.

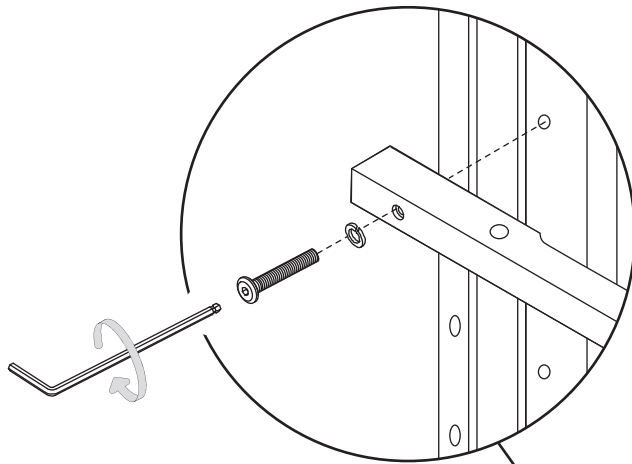

x4

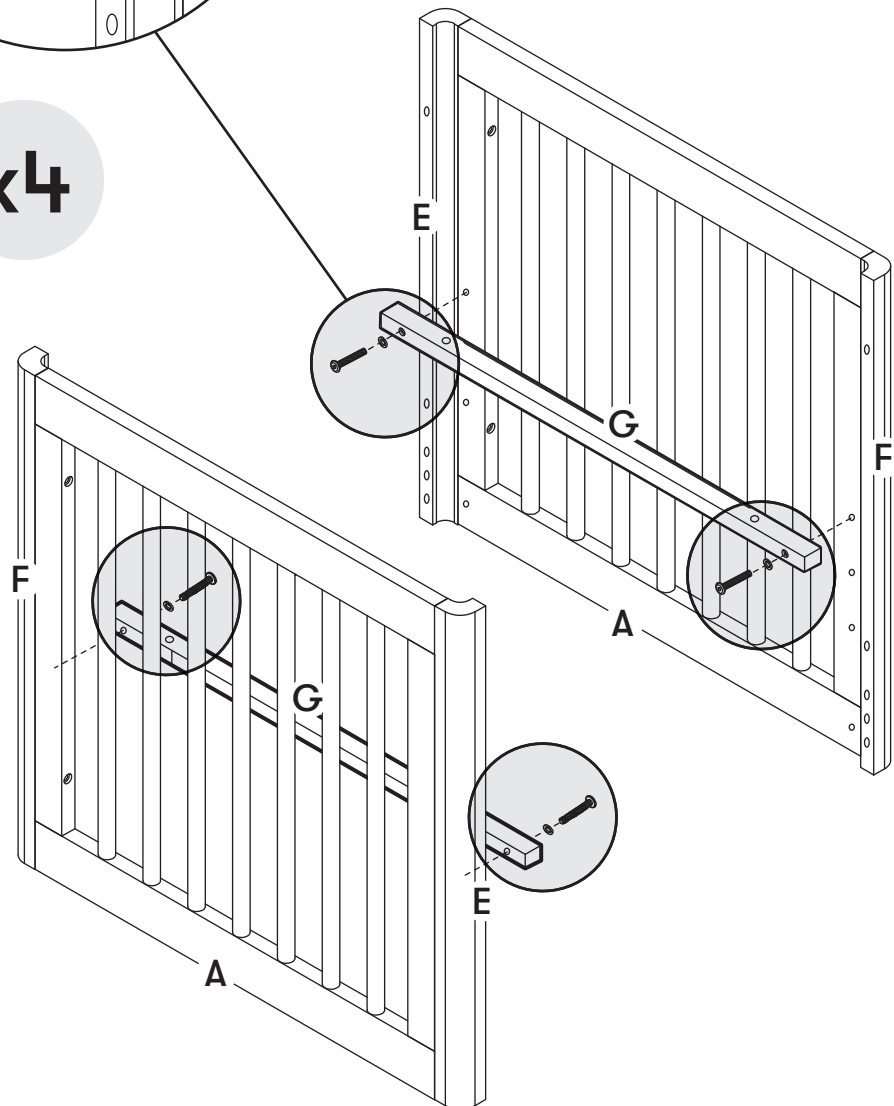



3

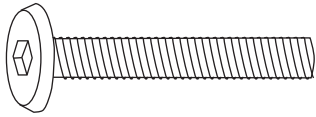

H5  
x4



H9  
x4

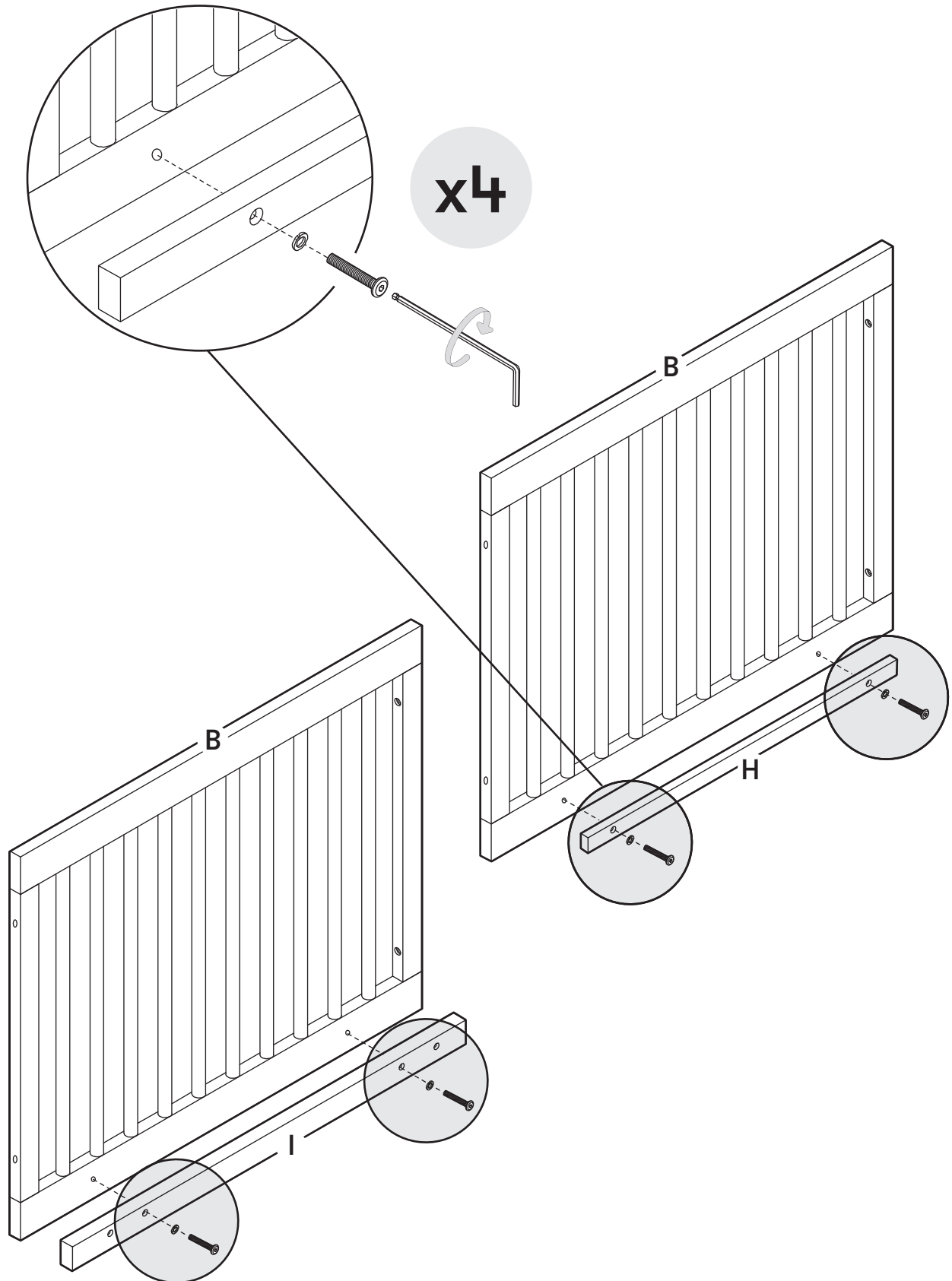

4

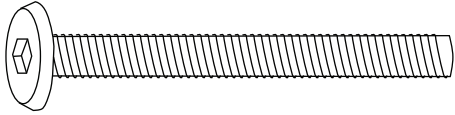

H3  
x4



H9  
x4

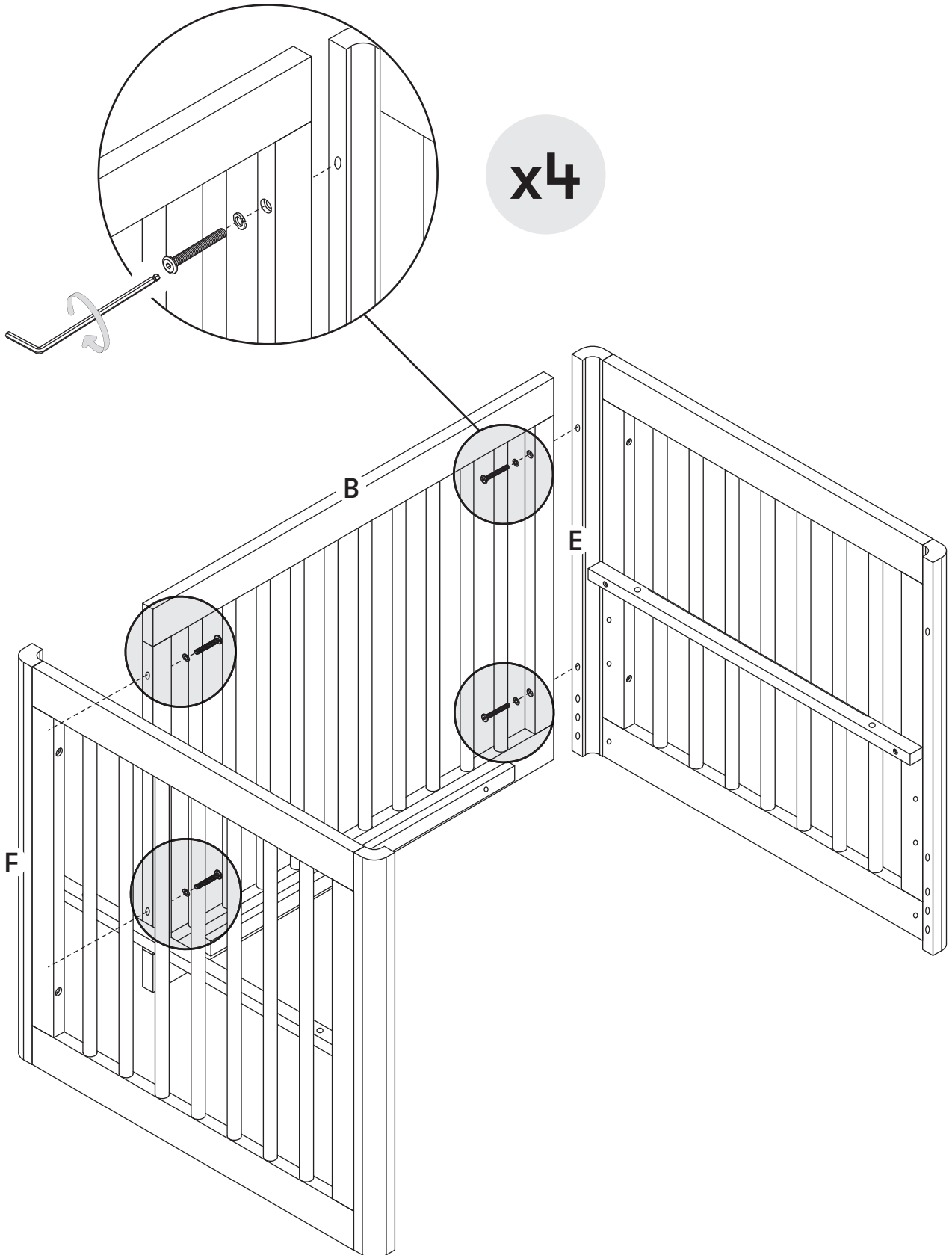

5

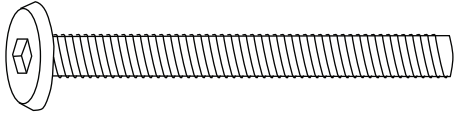

H3  
x4



H9  
x4

x4

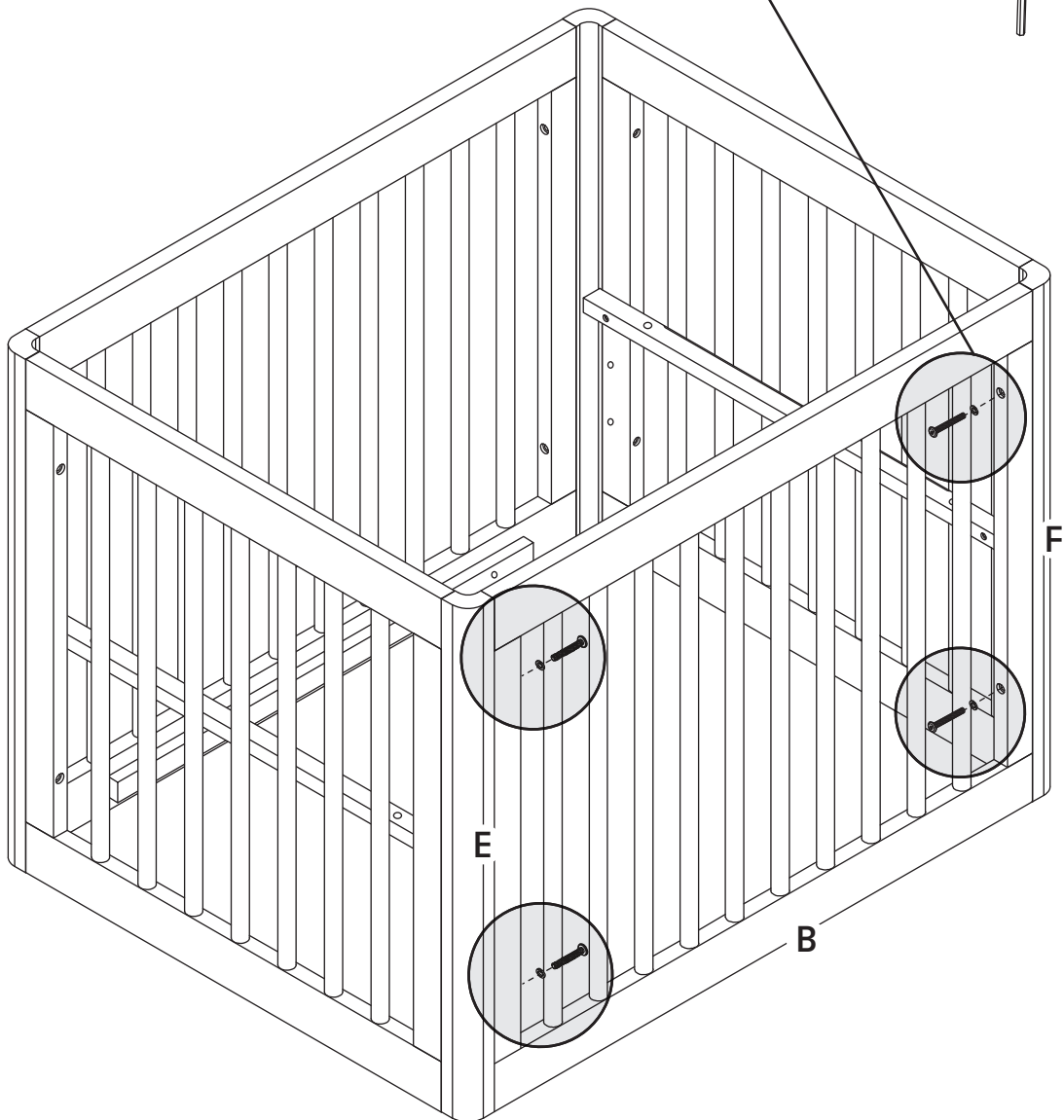
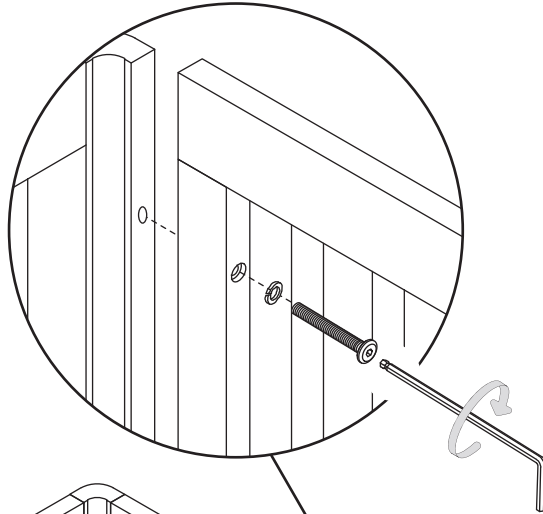

6

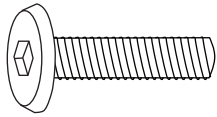

H6  
x4



H9  
x4

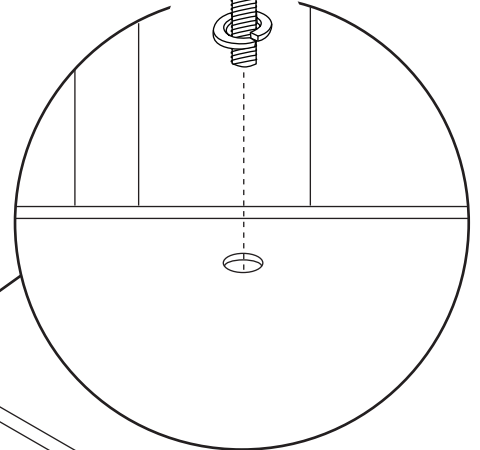
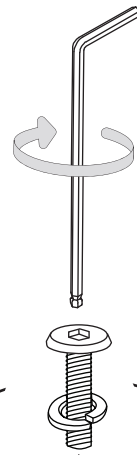

x4

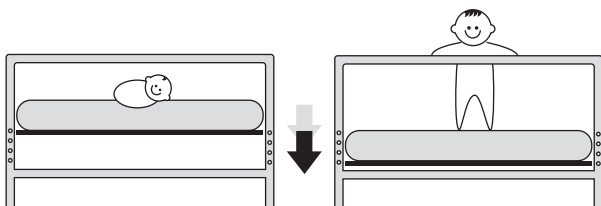
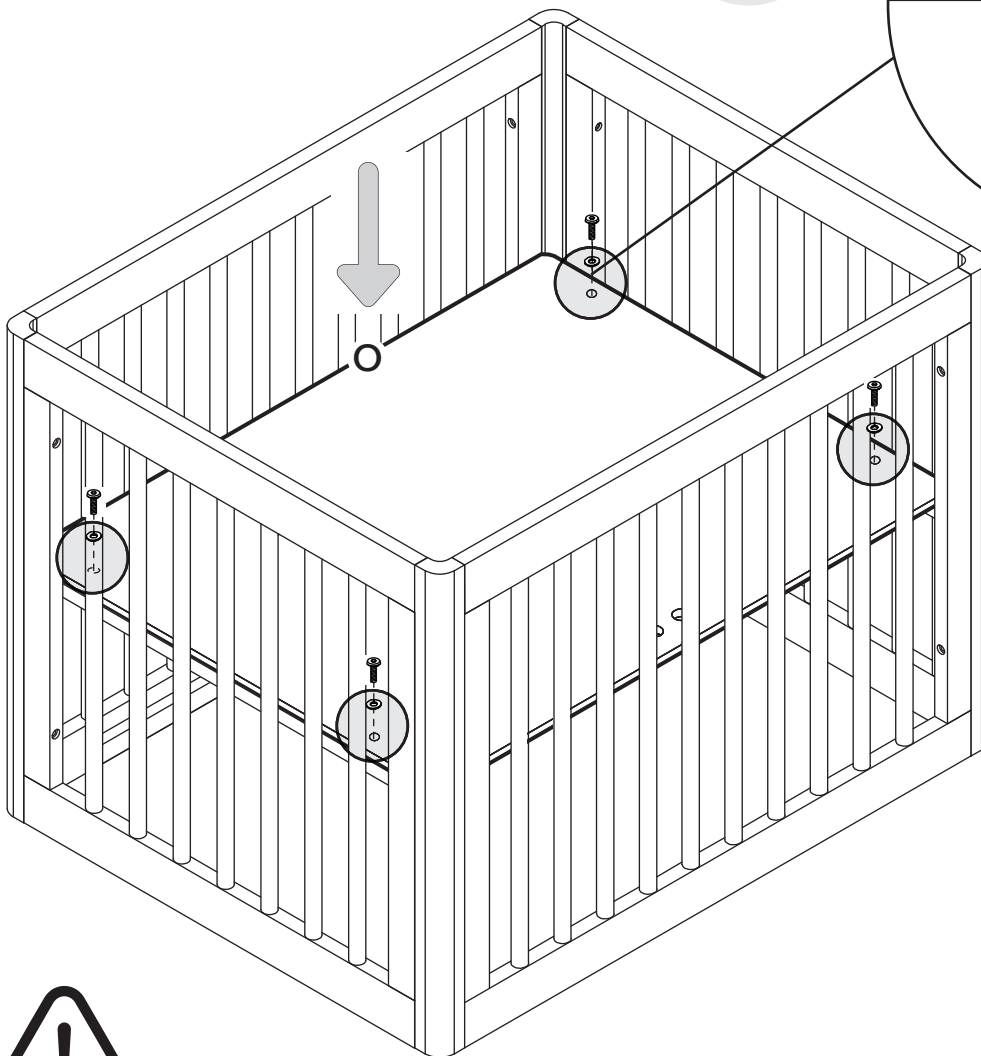

Lower the support as your child grows.

Baje el soporte a medida que vaya creciendo el niño.

Abaissez le support à mesure que votre enfant grandit.

7

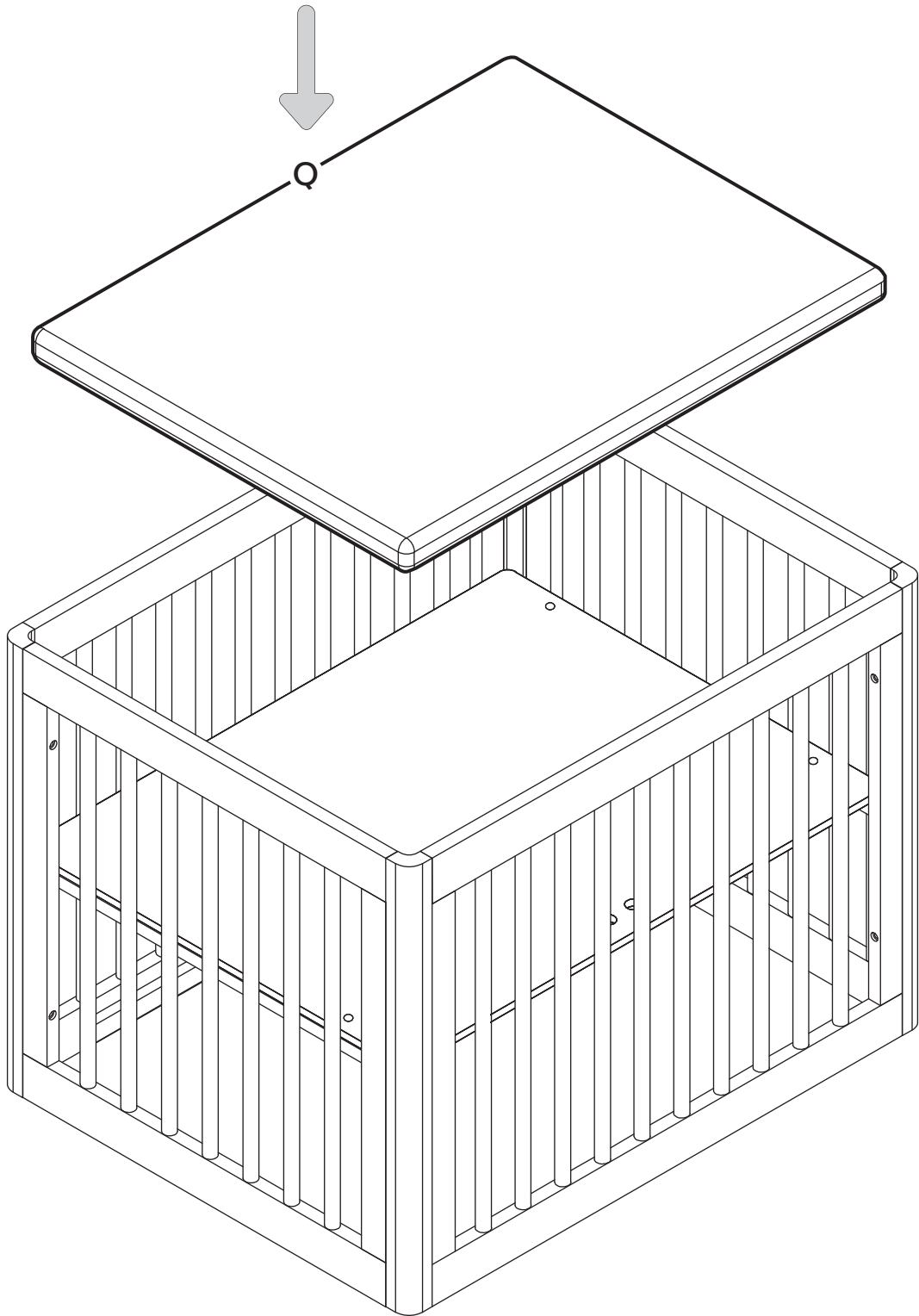

8

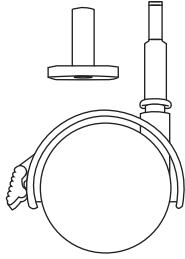

H12  
x4

**Optional / Opcional / En option :**

- \* Tighten firmly until the casters snap into place.  
Be sure the casters can turn freely.
- \* Apretar firmemente hasta que las ruedas encajen con un chasquido en su lugar.  
Revisar que las ruedas puedan girar libremente.
- \* Qu'ils de ce jusqu'à de fermement d'appuyer rentrer de jeu de caractères. Être sur que les casters peut tourner librement.

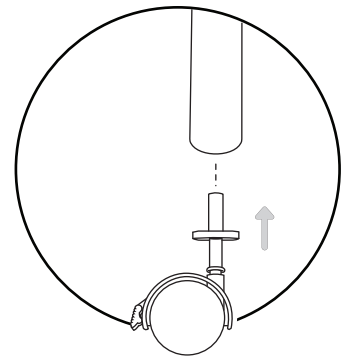
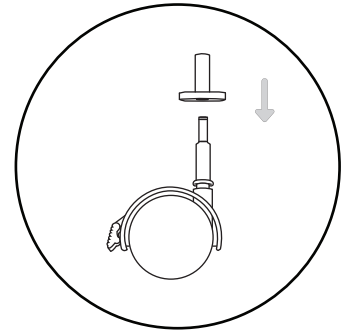

x4

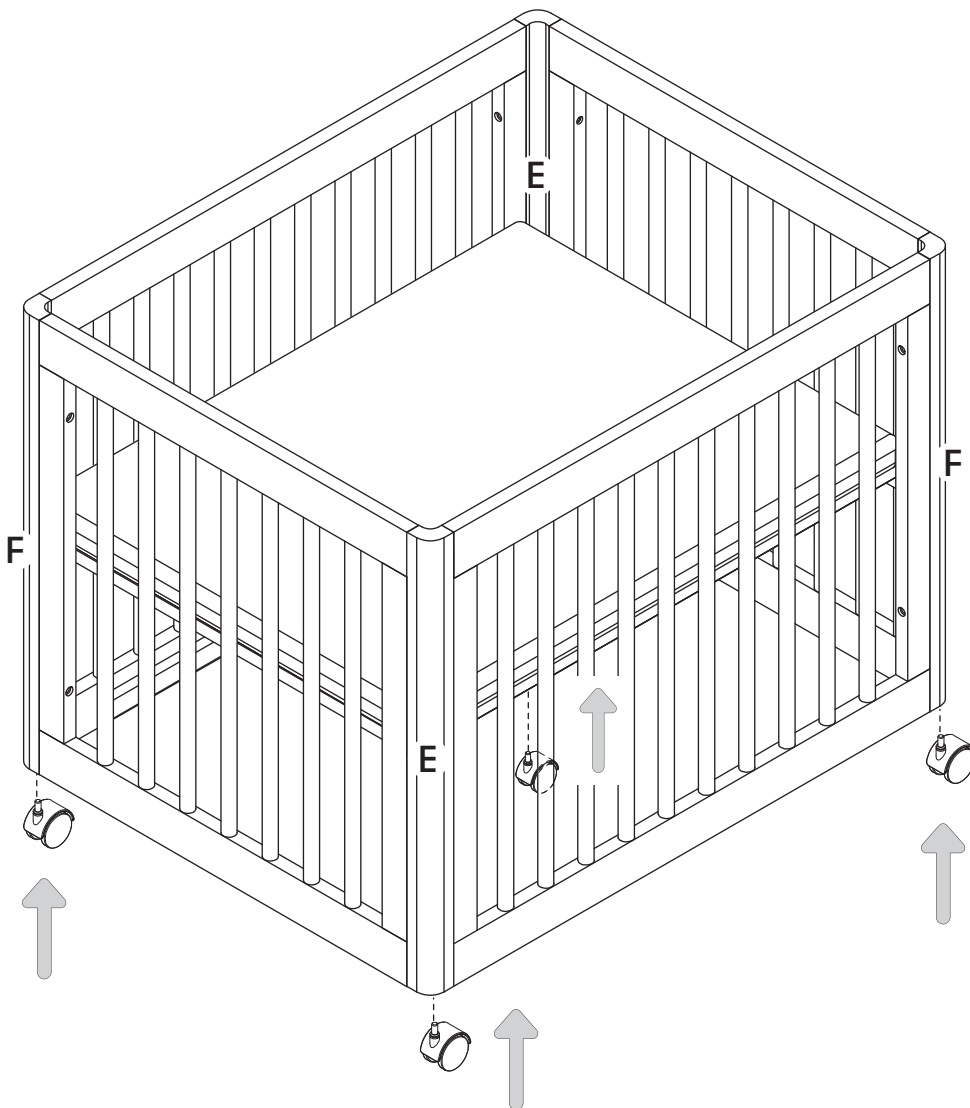

*Voilà!*

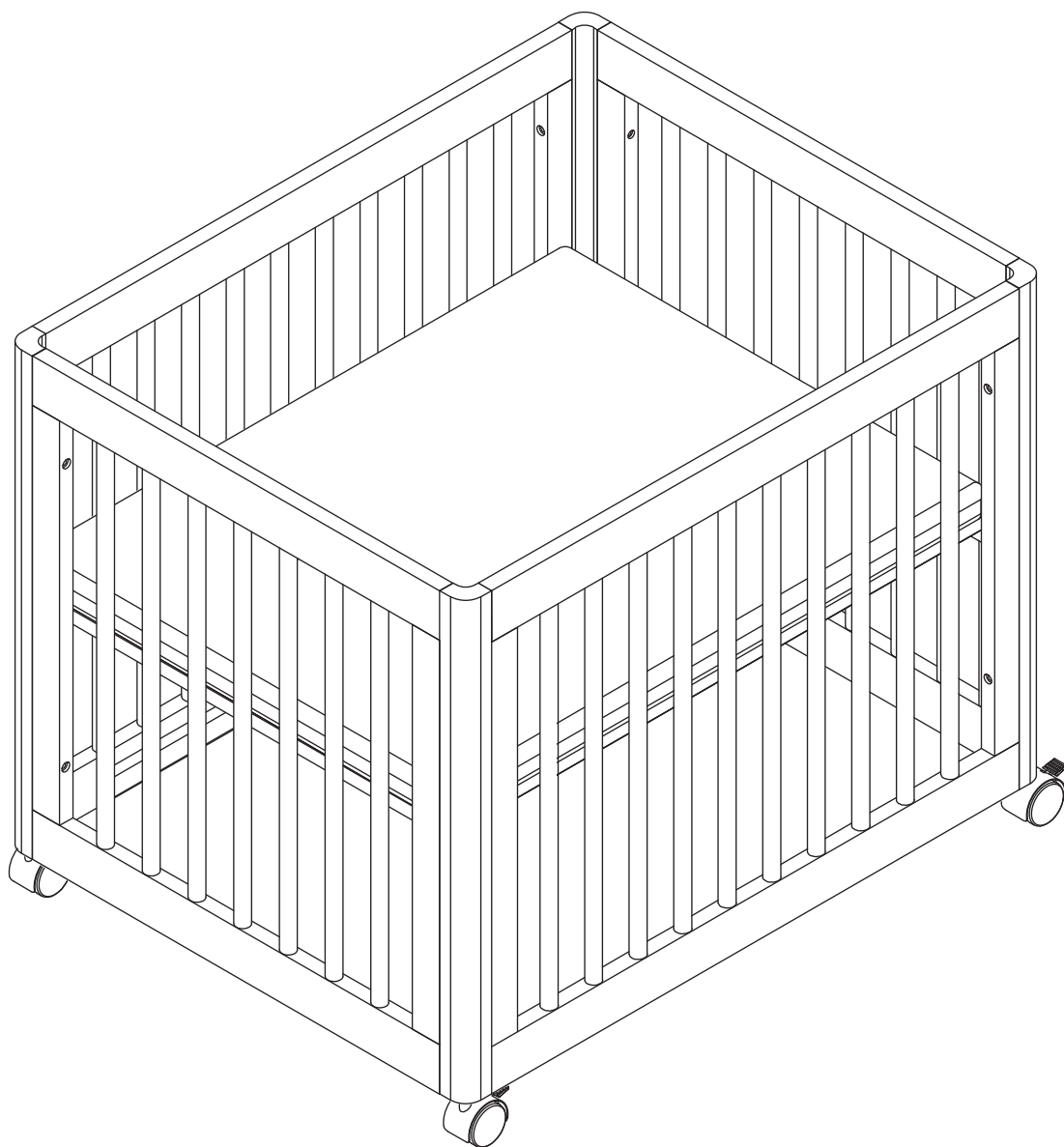

# WARNING

Failure to follow these warnings and the instructions could result in serious injury or death.

The product, including side rails, must be fully erected prior to use.

Infants can suffocate on soft bedding. Never add a pillow, comforter or padding.

To reduce the risk of SIDS, pediatricians recommend healthy infants be placed on their backs to sleep, unless otherwise advised by your physician.

Strings can cause strangulation! Do not place items with a string around a child's neck, such as strings or pacifier cords. Do not suspend strings over a crib or attach strings to toys.

To help prevent strangulation tighten all fasteners. A child can trap parts of the body or clothing on loose fasteners.

DO NOT place a crib near a window where cords from blinds or drapes may strangle a child.

When a child is able to pull to a standing position, set the mattress to the lowest position and remove bumper pads, large toys and other objects that could serve as steps for climbing out.

For cribs with drop sides, after raising side, make sure latches are secure.

For cribs with drop sides, DO NOT leave child in crib with side lowered. Be sure side is in raised and locked position whenever child is in crib.

When a child is able to climb out, reaches the height of 35 inches (890 mm), the child should be placed in a youth or regular bed, and the crib shall no longer be used.

Check this product for damaged hardware, loose joints, missing parts or sharp edges before and after assembly and frequently during use. DO NOT use crib if any parts are missing, damages or broken. Contact Babyletto for replacement parts and instructional literature if needed. DO NOT substitute parts.

NEVER use a water mattress with this product.

For cribs equipped with teething rails, replace teething rail if damaged, cracked or loose.

If refinishing, use a non-toxic finish specified for children's products.

Never use plastic shipping bags or other plastic films as mattress covers not sold and intended for purpose. They can cause suffocation.

Infants can suffocate in gaps between crib sides when used with a mattress that is too small.

Check fasteners periodically for tightness. Do not overtighten. This may cause distortion or breakage.

Use a crib, not as a play pen. Remember that a crib is not a substitute for parent's supervision.



# **WARNING**

When re-assembling the crib for your second child, please keep in mind that the screw holes will need to be filled in order for the screws to grip the wood. Talk to your local hardware store or lumber yard about how to do this properly.

Child can become entrapped and die when improvised netting or covers are placed on top of a play yard. Never add such items to confine child in play yard.

Always provide the supervision necessary for the continued safety of your child. When used for playing, never leave child unattended.

## **infants can suffocate**

- In gaps between a mattress too small or too thick and product sides
- On soft bedding

NEVER add a mattress, pillow, comforter, or padding.

Recheck all screws and bolts to be sure they are fastened securely.

Please DO NOT remove any wood screws in the normal disassembly of the crib.

DO NOT OVERTIGHTEN.

READ ALL INSTRUCTIONS BEFORE ASSEMBLING CRIB.

KEEP THIS MANUAL IN A SAFE PLACE FOR FUTURE REFERENCE.

## **CAUTION:**

Use **ONLY** mattress/pad provided by manufacturer (which must be at least 35.75 in. (90.8 cm) long by 28 in. (71.7 cm) wide and not more than 4 in. (10.2 cm) thick).

## ADVERTENCIA:

Si no se siguen estas advertencias y las instrucciones podría ocasionar lesiones serias o fatales.

El producto, incluidos los carriles laterales, debe estar totalmente armado antes del uso.

Los bebés pueden asfixiarse sobre la ropa de cama blanda. Nunca agregue una almohada, edredón ni acolchados.

Para reducir el riesgo del síndrome de muerte infantil súbita (SMIS), los pediatras recomiendan poner a los bebés sanos boca arriba para dormir, a menos que su médico le indique otras instrucciones.

¡Las cuerdas pueden causar estrangulación! No ponga objetos que tengan cuerdas alrededor del cuello de un niño, como cordeles sueltos o de chupetes. No suspenda cuerdas encima de una cuna ni ponga cordeles en los juguetes.

Para ayudar a prevenir la estrangulación apriete bien todas las fijaciones. Pueden quedar atrapadas partes del cuerpo del niño o su ropa en las fijaciones sueltas.

NO ponga una cuna cerca de una ventana donde haya cordeles de persianas o cortinas que puedan estrangular a un niño.

Cuando el niño pueda pararse solo, ponga el colchón en la posición más baja y quite las almohadillas protectoras, los juguetes grandes y otros objetos que pudieran servir como peldaños para salir de la cuna.

En las cunas con costados abatibles, después de subir el costado, revise que los pestillos estén seguros.

En las cunas con costados abatibles, NO deje al niño en la cuna con el costado abajo. Revise que el costado esté arriba y en posición trabada siempre que esté el niño en la cuna.

Cuando un niño pueda salirse solo, llegando a medir 890 mm (35 pulgadas), debe poner al niño en una cama juvenil o normal, y no debe usar ya la cuna.

Revise este producto en busca de herraje dañado, juntas sueltas, piezas faltantes o bordes afilados antes y después del ensamblaje y frecuentemente durante el uso. NO use la cuna si hay alguna pieza que falta, está dañada o rota. Contacte a Babyletto si necesita piezas de repuesto y documentación con instrucciones. NO sustituya piezas.

NUNCA use un colchón de agua con este producto.

En las cunas equipadas con carriles aptos para dentición, cambie el carril de dentición si está dañado, agrietado o suelto.

Si va a retocar el acabado, use un acabado no tóxico especificado para productos infantiles.

Nunca utilice bolsas plásticas de envío ni otros tipos de película plástica para proteger el colchón ya que no se venden ni destinan a este uso. Pueden causar asfixia.

Los bebés pueden asfixiarse en los huecos entre los costados de la cuna cuando se usa con un colchón que sea muy pequeño.

Revise las fijaciones periódicamente para confirmar que están apretadas. No apriete en exceso. Esto puede causar distorsión o roturas.

## **⚠️ ADVERTENCIA:**

Se debe usar como cuna, no como corral de juego. Recuerde que una cuna no sustituye la supervisión de los padres.

Al volver a armar la cuna para su segundo hijo, tenga presente que los agujeros de los tornillos deben rellenarse para que los tornillos se agarren bien a la madera. Consulte con su ferretería o maderería local acerca de cómo hacer esto correctamente.

El niño puede quedar atrapado y morir cuando se ponen mallas o cubiertas improvisadas encima de un corral de juego. Nunca agregue estas cosas para encerrar al niño en un corral de juego.

Siempre cuente con la supervisión necesaria para la seguridad continua de su hijo. Cuando se use para jugar, nunca deje al niño sin supervisión.

### **los bebés pueden asfixiarse**

- En los huecos entre un colchón muy pequeño o muy grueso y los lados del producto
- Sobre la ropa de cama blanda

NUNCA agregue un colchón, almohada, edredón ni acolchados.

Vuelva a revisar todos los tornillos y pernos para comprobar que estén apretados firmemente.

NO quite ningún tornillo para madera al desarmar normalmente la cuna.

NO APRIETE EN EXCESO.

LEA TODAS LAS INSTRUCCIONES ANTES DE ENSAMBLAR LA CUNA.

CONSERVE ESTE MANUAL EN UN LUGAR SEGURO PARA REFERENCIA FUTURA.

## **PRECAUCIÓN:**

Use **SOLO** la colchón / colchoneta provista por el fabricante (debe medir por lo menos 90.8 cm (35.75 pulgadas) por 71.7 cm (28 pulgadas) y tener un espesor que no supere 10.2 cm (4 pulgadas) .

## **AVERTISSEMENT:**

Le non-respect des avertissements et des instructions peut conduire à une blessure grave ou à la mort.

Les nouveau-nés peuvent suffoquer sur une literie douce. Ne jamais ajouter d'oreiller, de couvre-pied piqué ou de garniture.

Pour réduire les risques de SMSN, les pédiatres recommandent de placer les nouveau-nés sur le dos pendant le sommeil à moins que vous soyez conseillé autrement par votre médecin.

Les ficelles peuvent causer une strangulation! Ne pas placer un objet contenant des ficelles à l'exemple des ficelles de capuchon ou des cordes de sucettes, autour du cou d'un enfant. Ne pas suspendre des ficelles au dessus du lit ou attacher des ficelles aux jouets.

Afin de prévenir toute strangulation, bien serrer tout les pièces d'attaches. Les vêtements ou l'enfant pourraient être pris au piège par des pièces d'attaches desserrées.

NE PAS placer un lit devant une fenêtre dont les cordes des stores ou rideaux pourraient étrangler un enfant.

Lorsqu'un enfant est capable de se tenir debout, mettre le matelas à sa position la plus basse et retirer la bordure de protection, les grands jouets ou tout autre objet dont l'enfant pourrait se servir pour sortir du lit.

Pour les lits possédant des parois rabattables, assurez-vous que les loquets sont sécurisés.

Pour les lits à parois rabattables, NE PAS laisser un enfant dans le lit si le côté est abaissé. Assurez-vous que la paroi est élevée et fermé chaque fois que l'enfant est dans le lit.

Lorsqu'un enfant est capable de sortir du lit ou atteint la hauteur de 890 mm (35 pouces), il doit être placé dans un lit de jeune ou un lit normal. L'utilisation du lit n'est plus nécessaire.

Procéder à une vérification du produit pour la recherche de matériel endommagé, jointures desserrées, des pièces manquantes ou des bords coupants avant et après l'assemblage et fréquemment pendant l'utilisation. Ne pas utiliser le lit si des pièces sont manquantes, endommagées ou cassées. Contacter Babyletto pour le remplacement des pièces et du manuel en cas de besoin. NE PAS substituer des pièces.

NE PAS utiliser des matelas à eau avec ce lit.

Pour les lits équipés de traverses à denture, remplacer les traverses à dentures au cas où elles sont endommagées, cassées ou desserrées.

En cas de finition, utiliser un produit non-toxique et recommandé pour les enfants.

Ne jamais utiliser des grands sacs en plastiques ou tout autre film plastique comme couverture de matelas car ils peuvent entraîner une suffocation.

## **⚠️ AVERTISSEMENT:**

Les enfants peuvent suffoquer dans les espaces entre les cotés du lit à barreaux lorsque vous utilisez un très petit matelas.

Vérifier régulièrement les pièces d'attaches pour leur fermeté. Ne pas trop serrer car, ceci pourrait causer une distorsion ou une casse.

Utiliser un lit à barreaux comme tel, pas comme un parc à jeux. Souvenez-vous que le lit à barreaux n'est pas un remplaçant du contrôle parental.

Pendant le nouvel assemblage du lit à barreaux pour votre deuxième enfant, rappelez-vous que les trous des vis doivent être remplis pour s'assurer que la vis tienne fermement au bois. Adressez-vous à votre magasin de matériel local ou menuisier pour avoir la bonne marche à suivre.

### **risque de suffocation**

- Dans les trous entre un matelas trop petit ou trop épais et les cotés du lit.
- Sur une literie douce.

NE JAMAIS ajouter de matelas, d'oreiller, de couvre-pied piqué ou de garniture.

Revérifier le serrage de tous les boulons et des vis.

Ne retirer aucune vis à bois pendant le désassemblage normal du lit à barreaux.

NE PAS TROP SERRER.

LIRE TOUTES LES INSTRUCTIONS AVANT D'ASSEMBLER LE LIT.

GARDER CE MANUEL EN LIEU SÛR POUR UN USAGE ULTÉRIEUR.

## **ATTENTION :**

**Utiliser UNIQUEMENT le matelas / coussin fourni par le fabricant (qui doit mesurer au moins 90,8 cm (35,75 po) de longueur par 71,7 cm (28 po) de largeur et pas plus de 10,2 cm (4 po) d'épaisseur).**

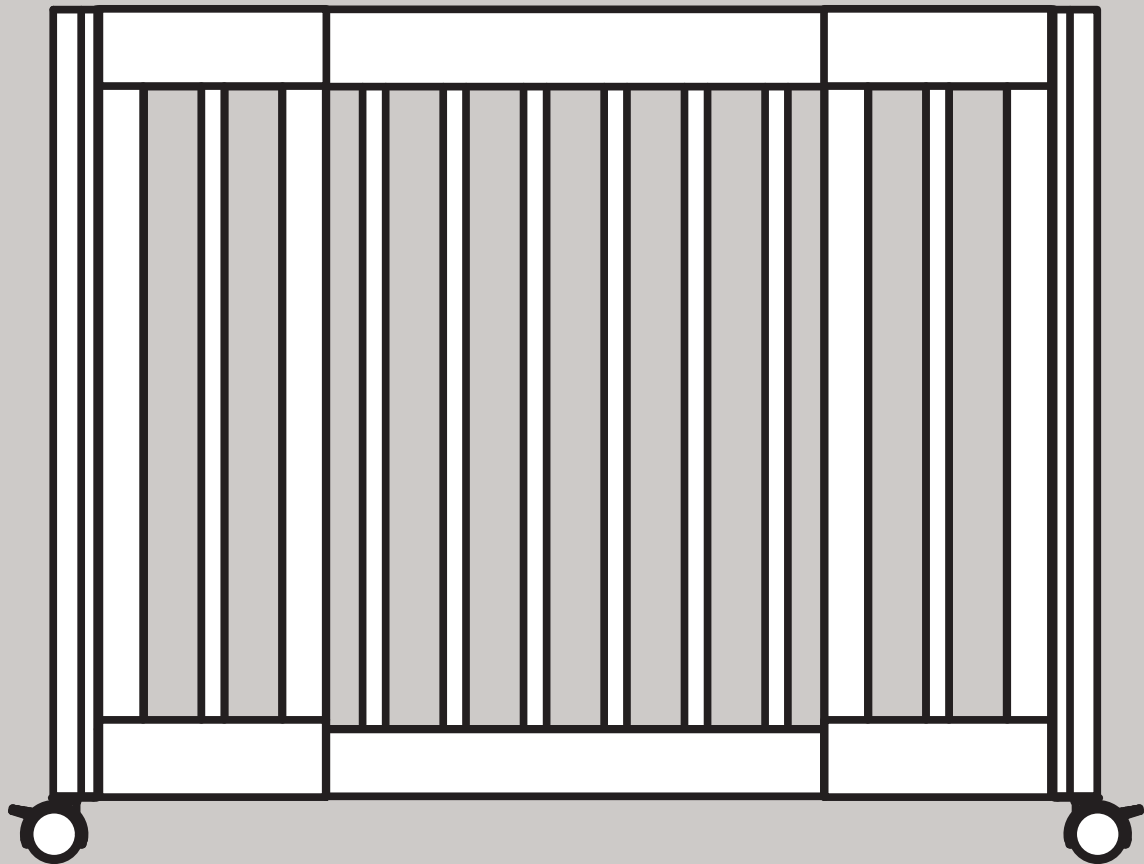

# Yuzu™ Midi Toddler Bed

M23401

Toddler bed conversion  
Conversión para cama  
de bebé que ya camina  
Conversion en lit de bébé

1

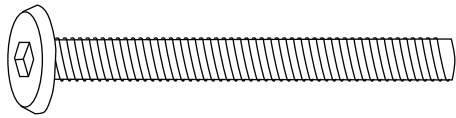

H3  
x4



H9  
x4

x4

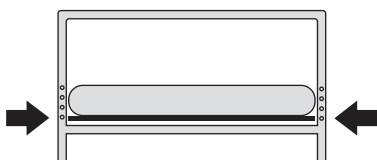
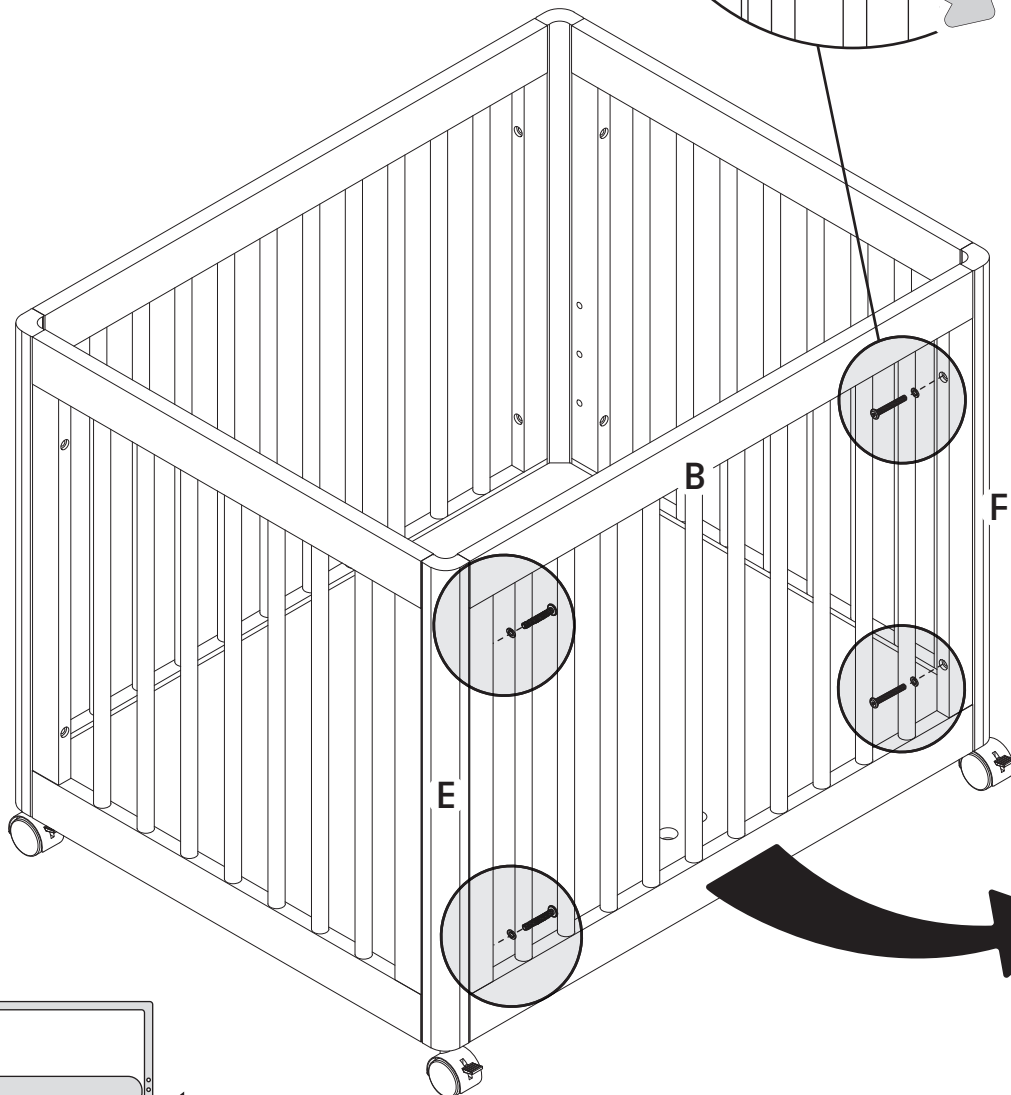
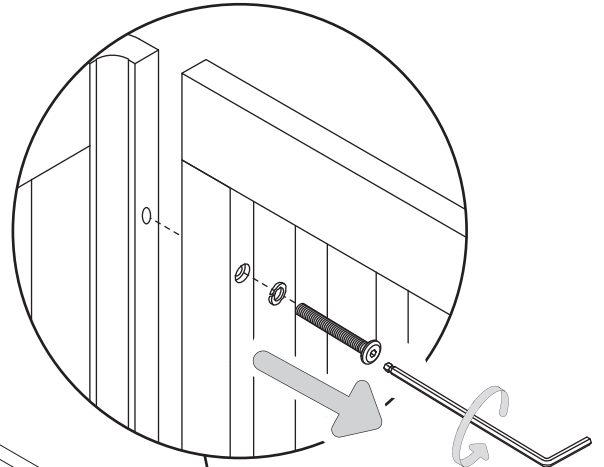

2

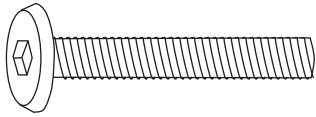

H5  
x2



H9  
x2

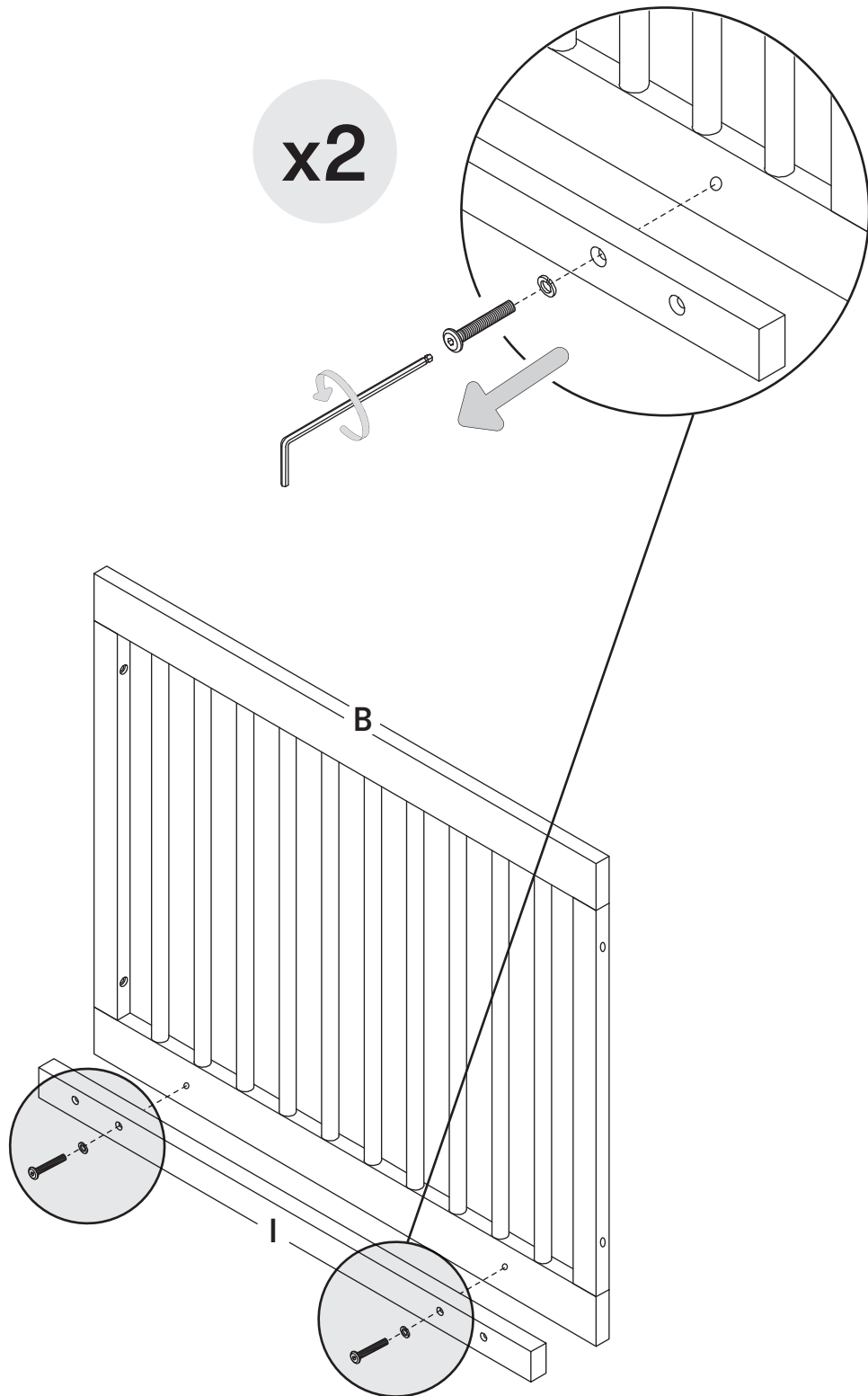



3

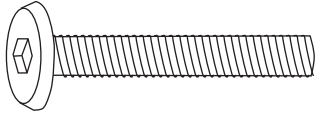

H5  
x4



H9  
x4

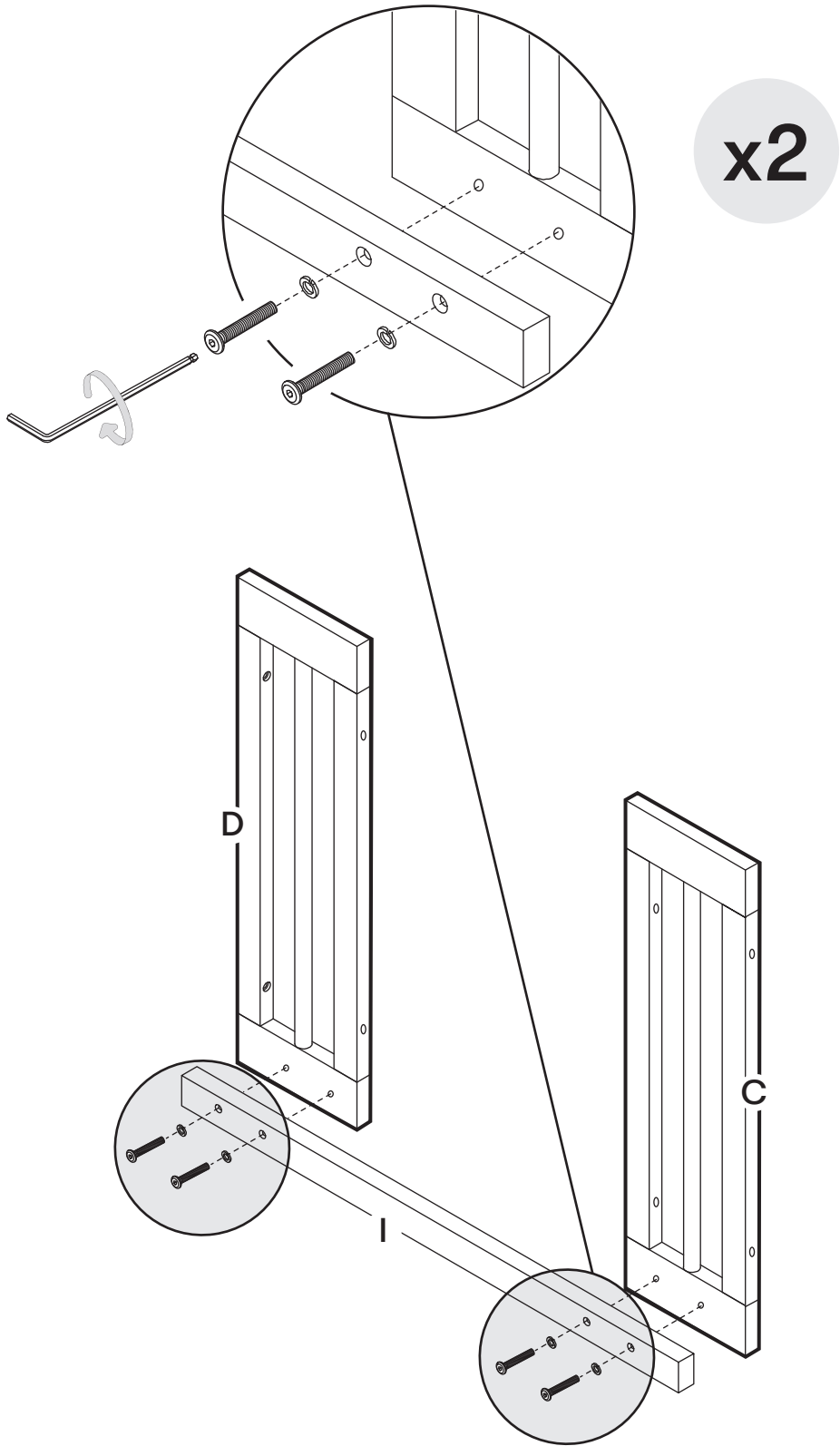

4

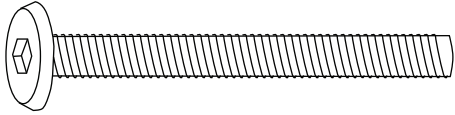

H3  
x4



H9  
x4

x4

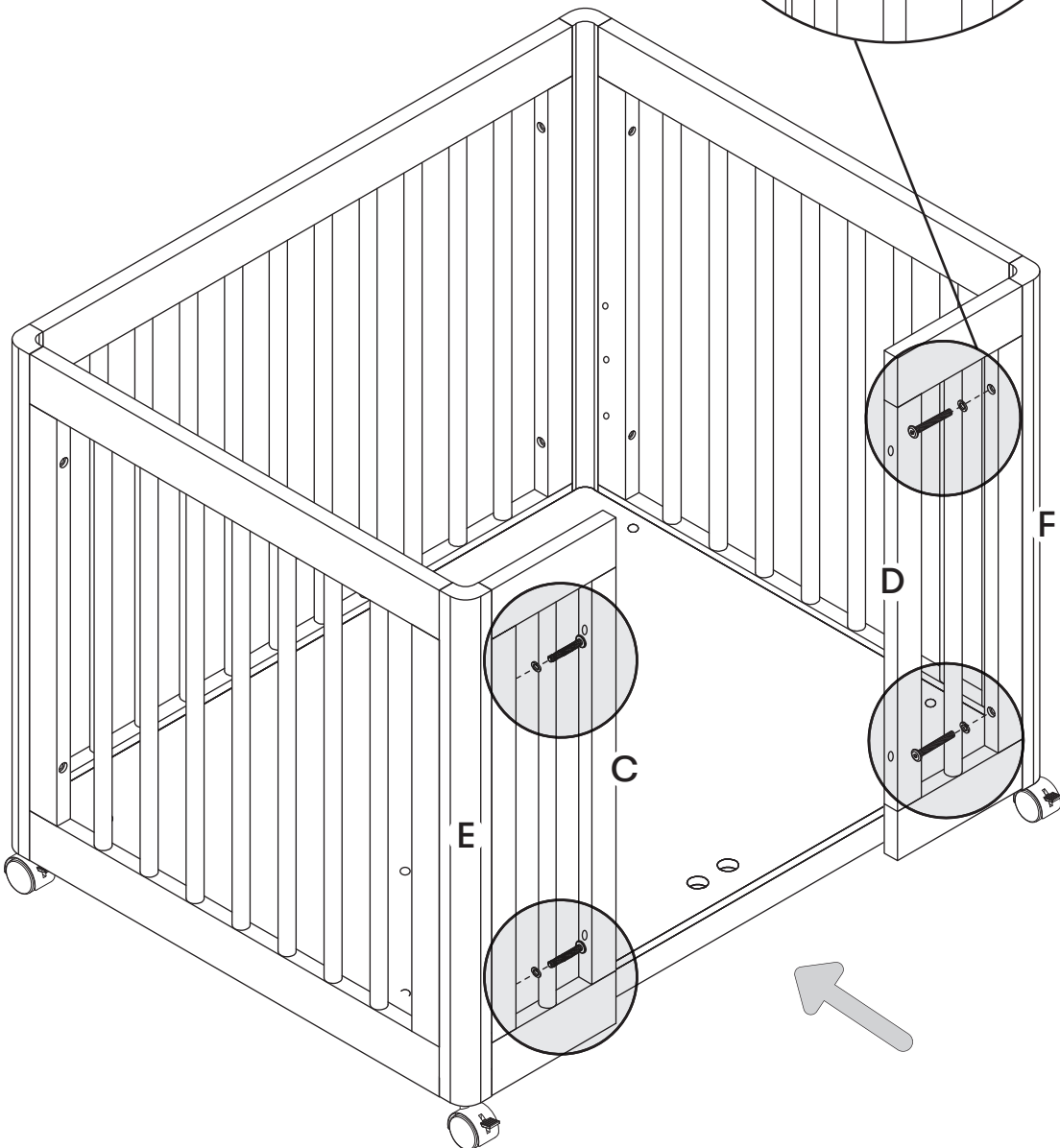
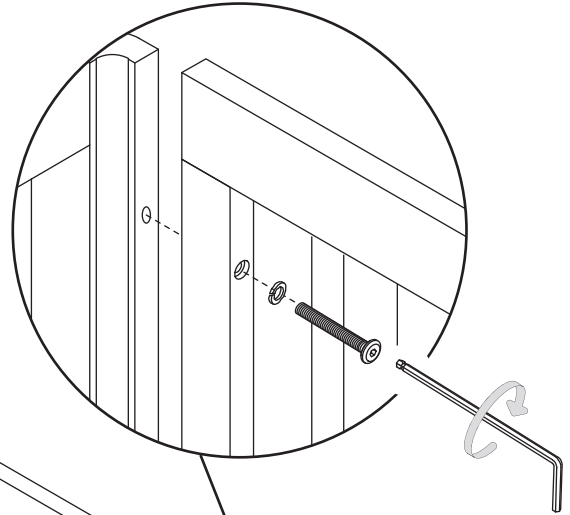

5

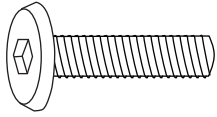

H6  
x4

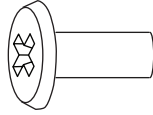

H11  
x4

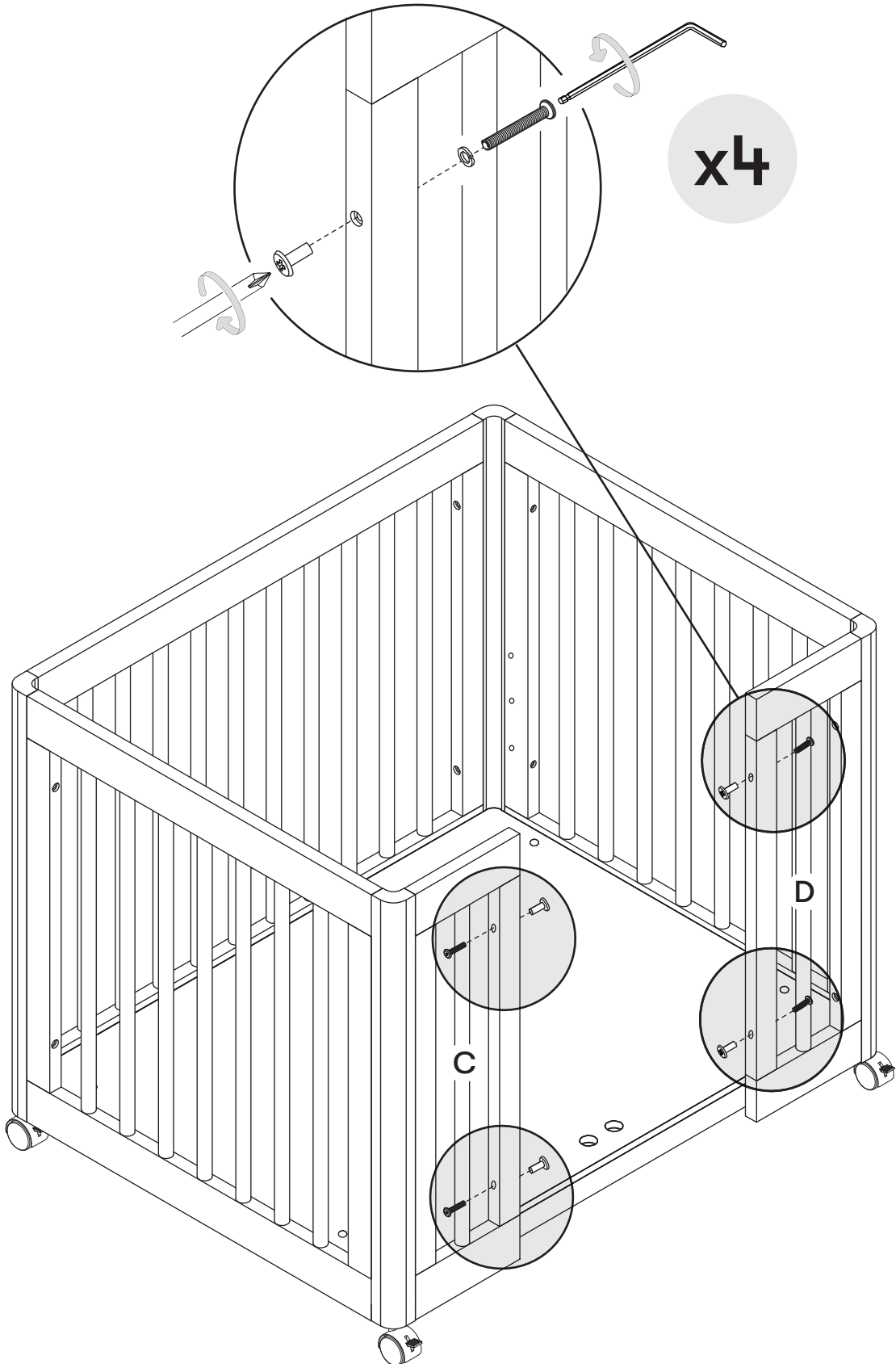

x4

*Voilà!*

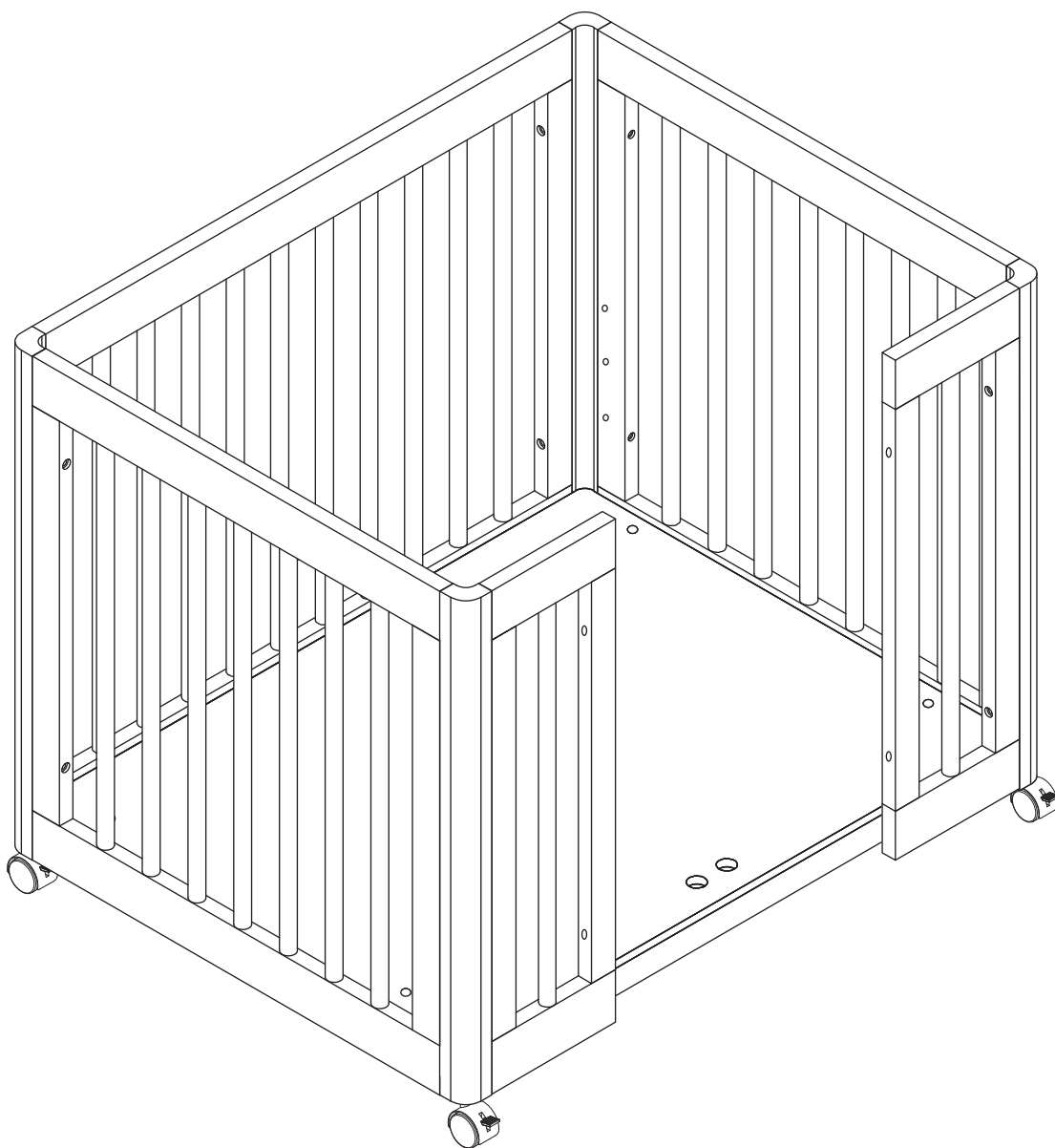

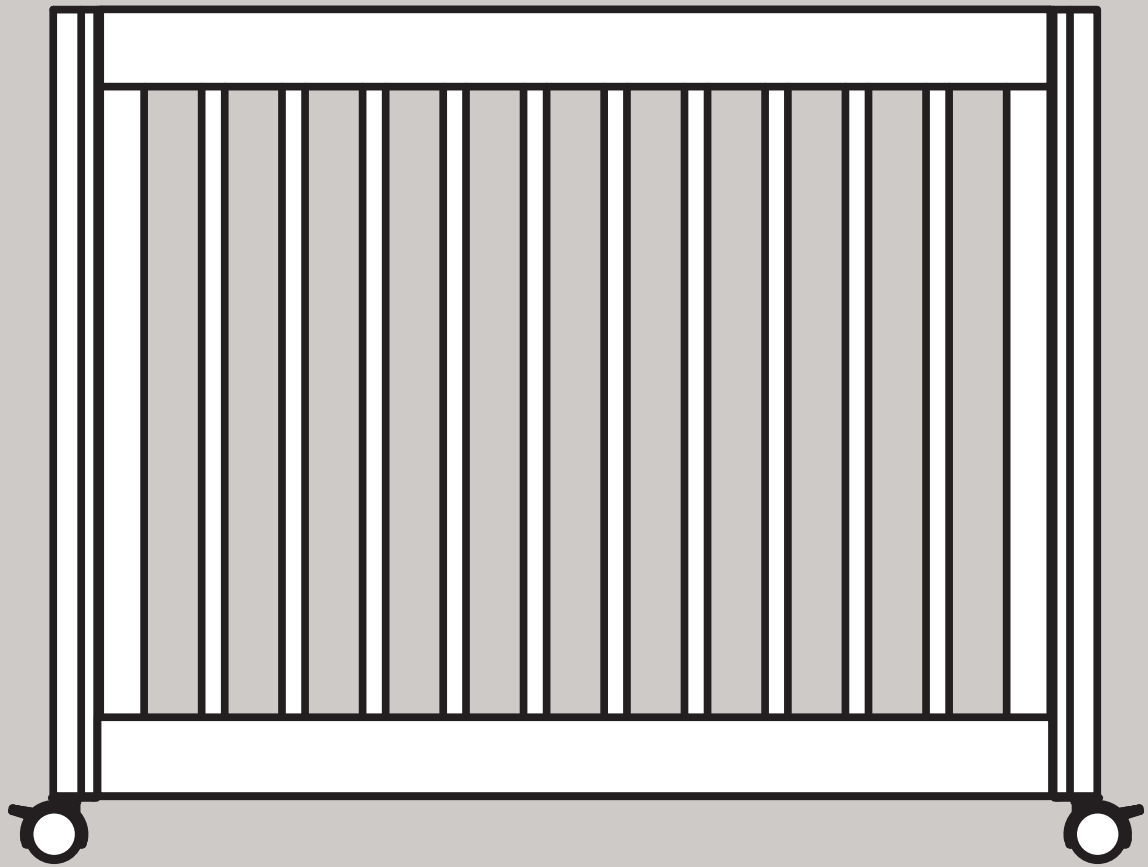

# Yuzu™ Midi Day Bed

M23401

Day bed conversion  
Conversión para diván  
Conversion en lit de jour

1

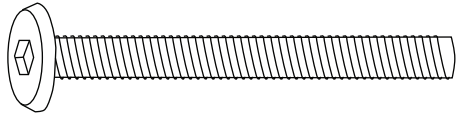

H3  
x4



H9  
x4

x4

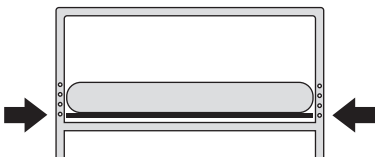
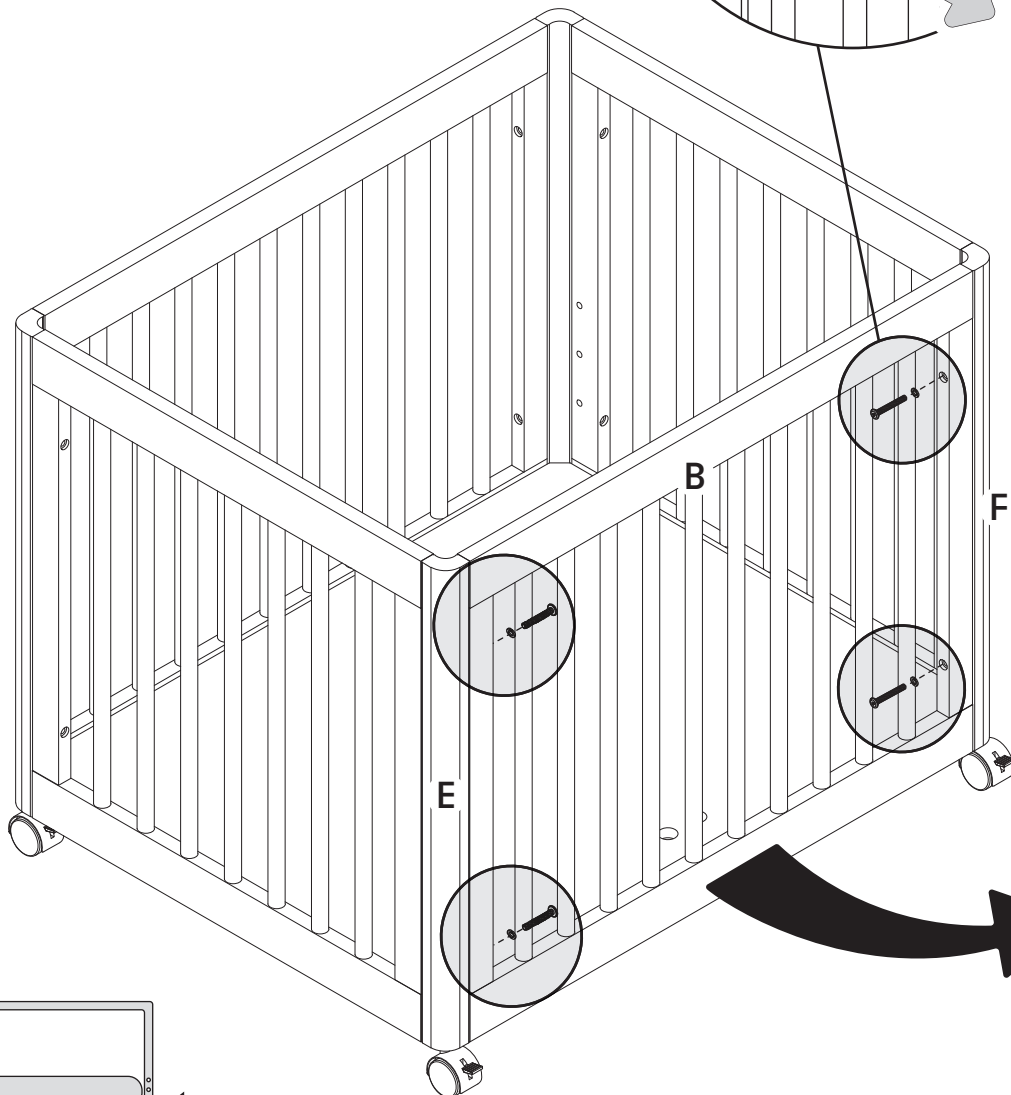
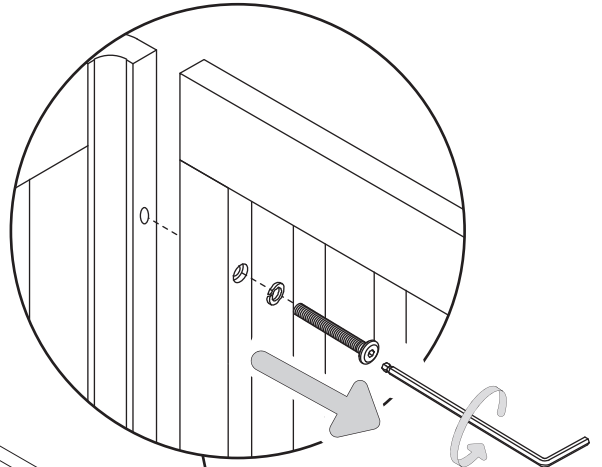

2

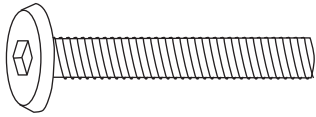

H5  
x2



H9  
x2

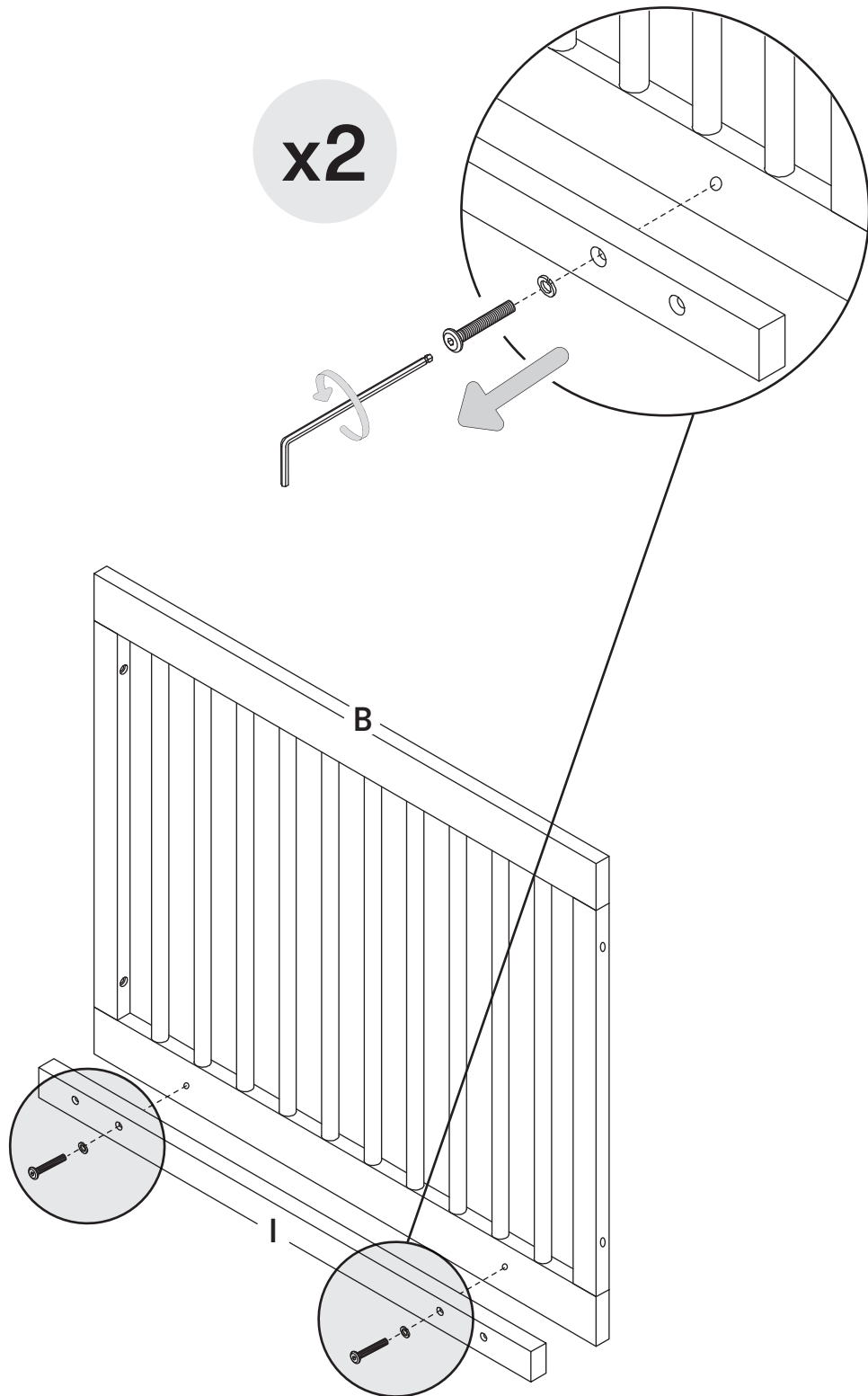

3

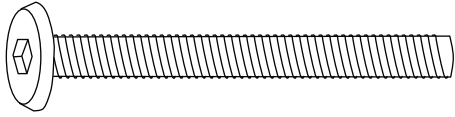

H3  
x4



H9  
x4

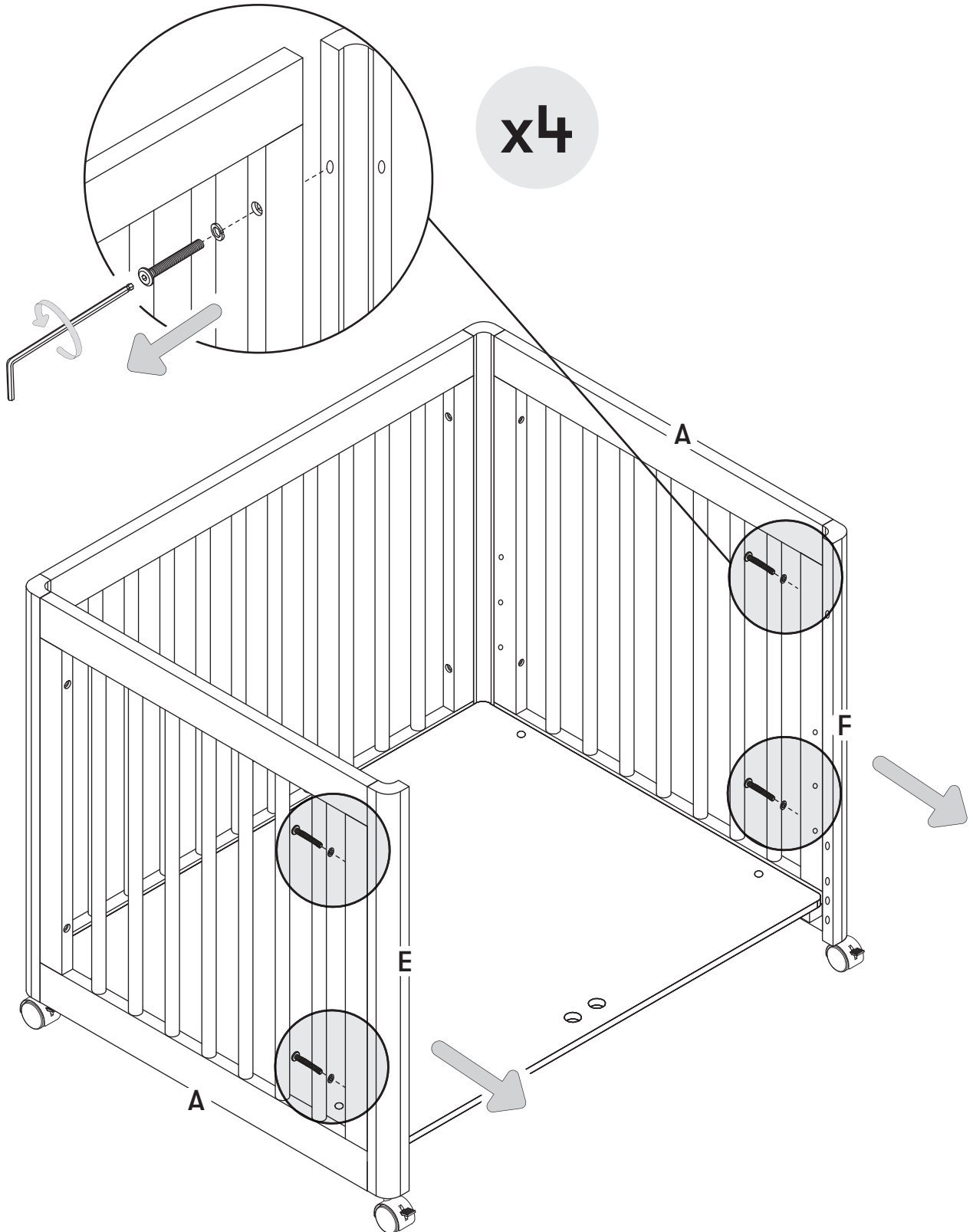



4

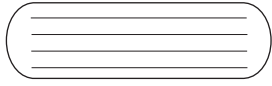

H10  
x4

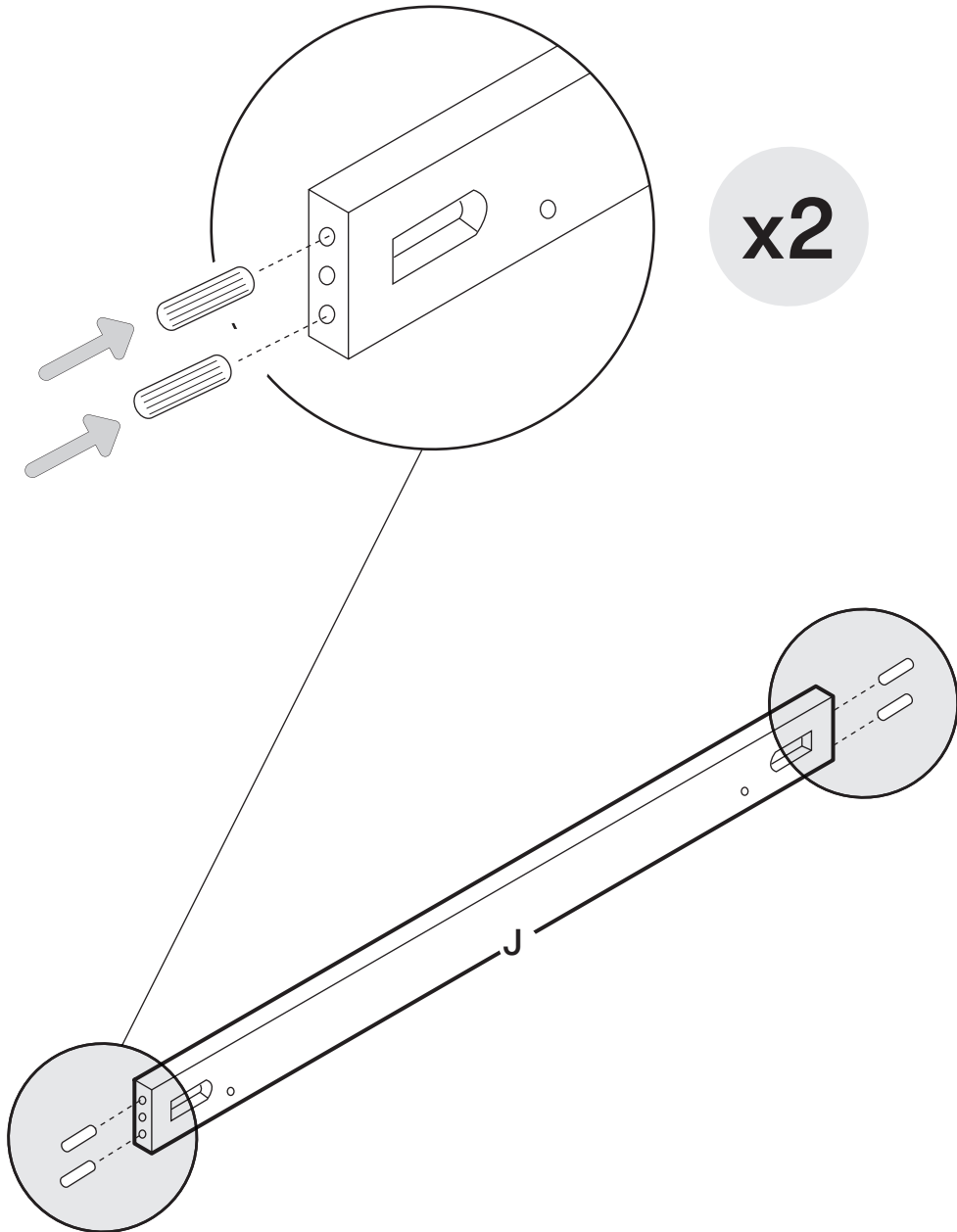

x2

5

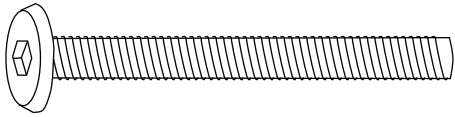

H3  
x2



H9  
x2

x2

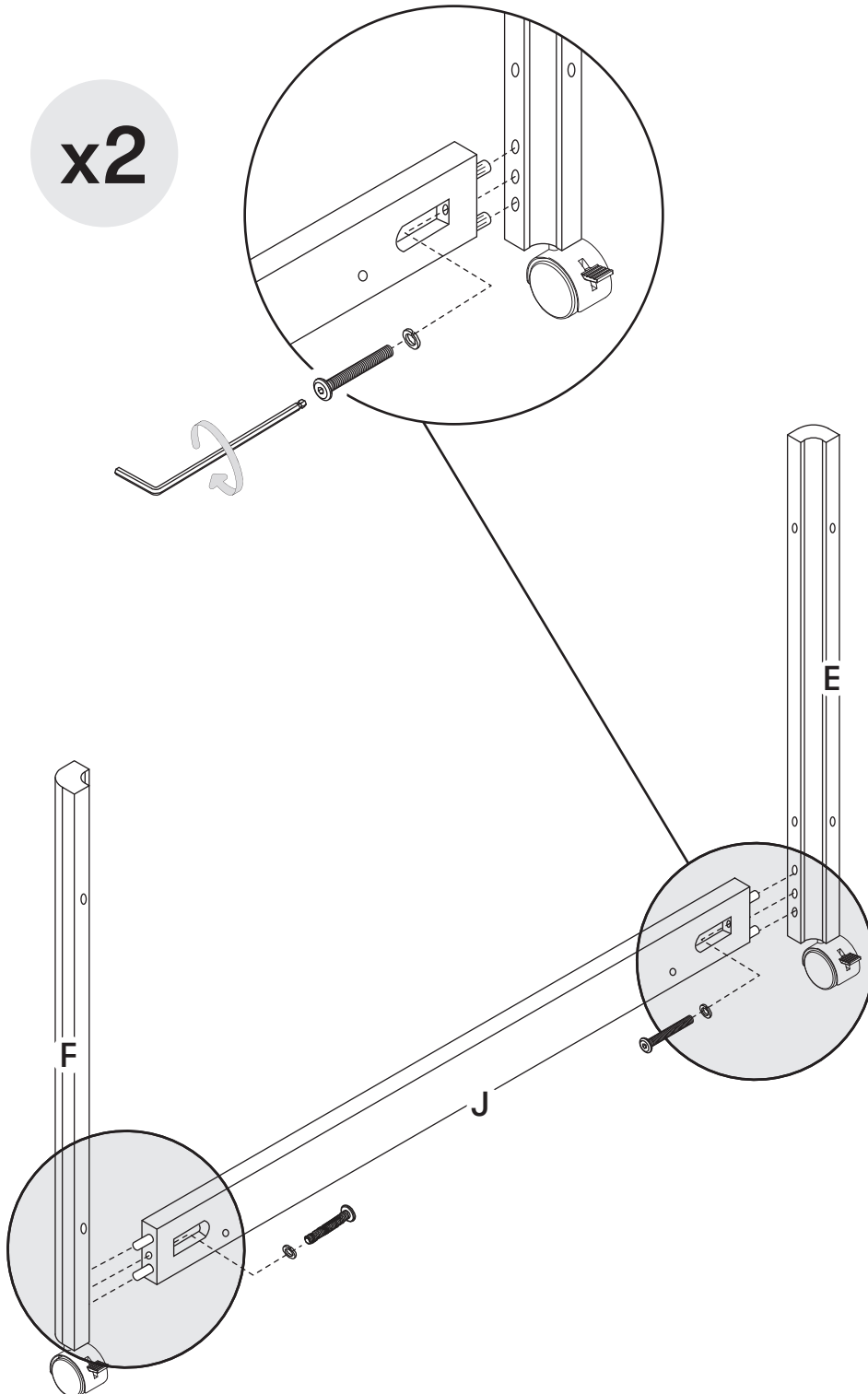

6

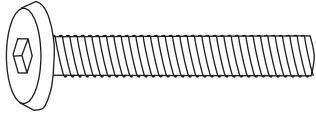

H5  
x2



H9  
x2

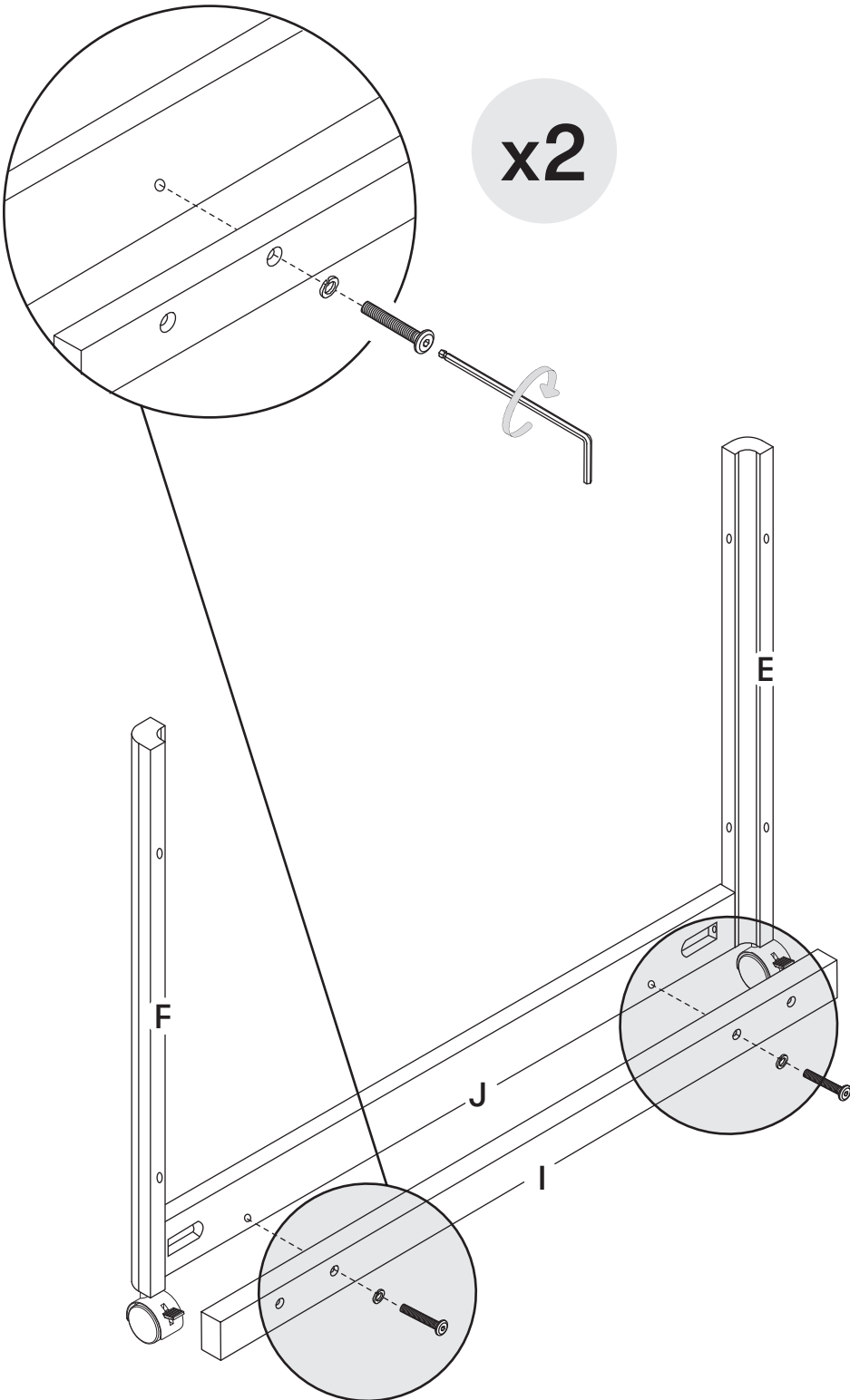

7

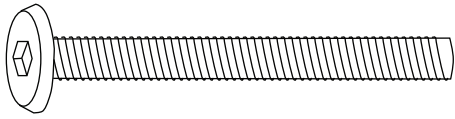

H3  
x4



H9  
x4

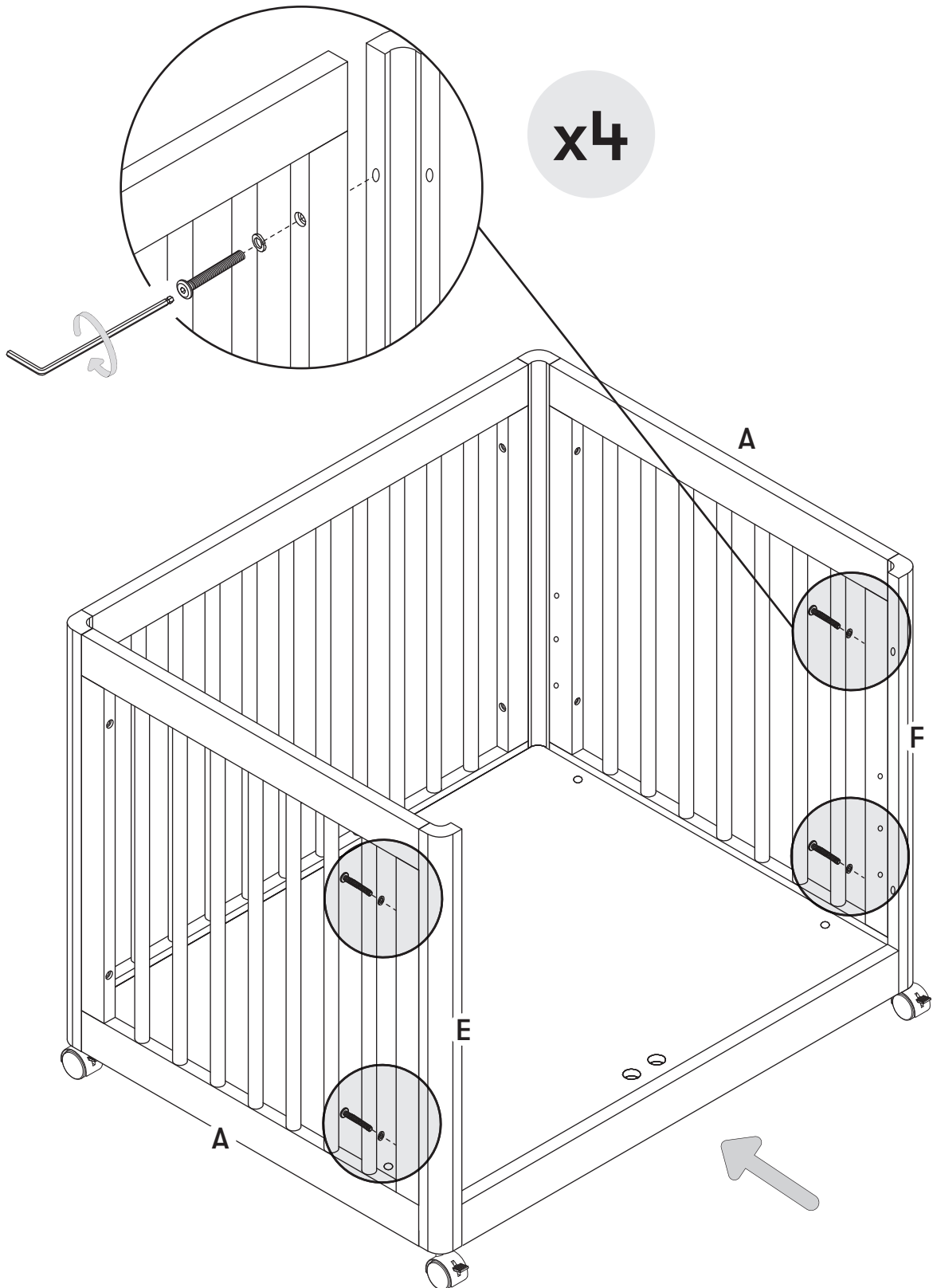

*Voilà!*

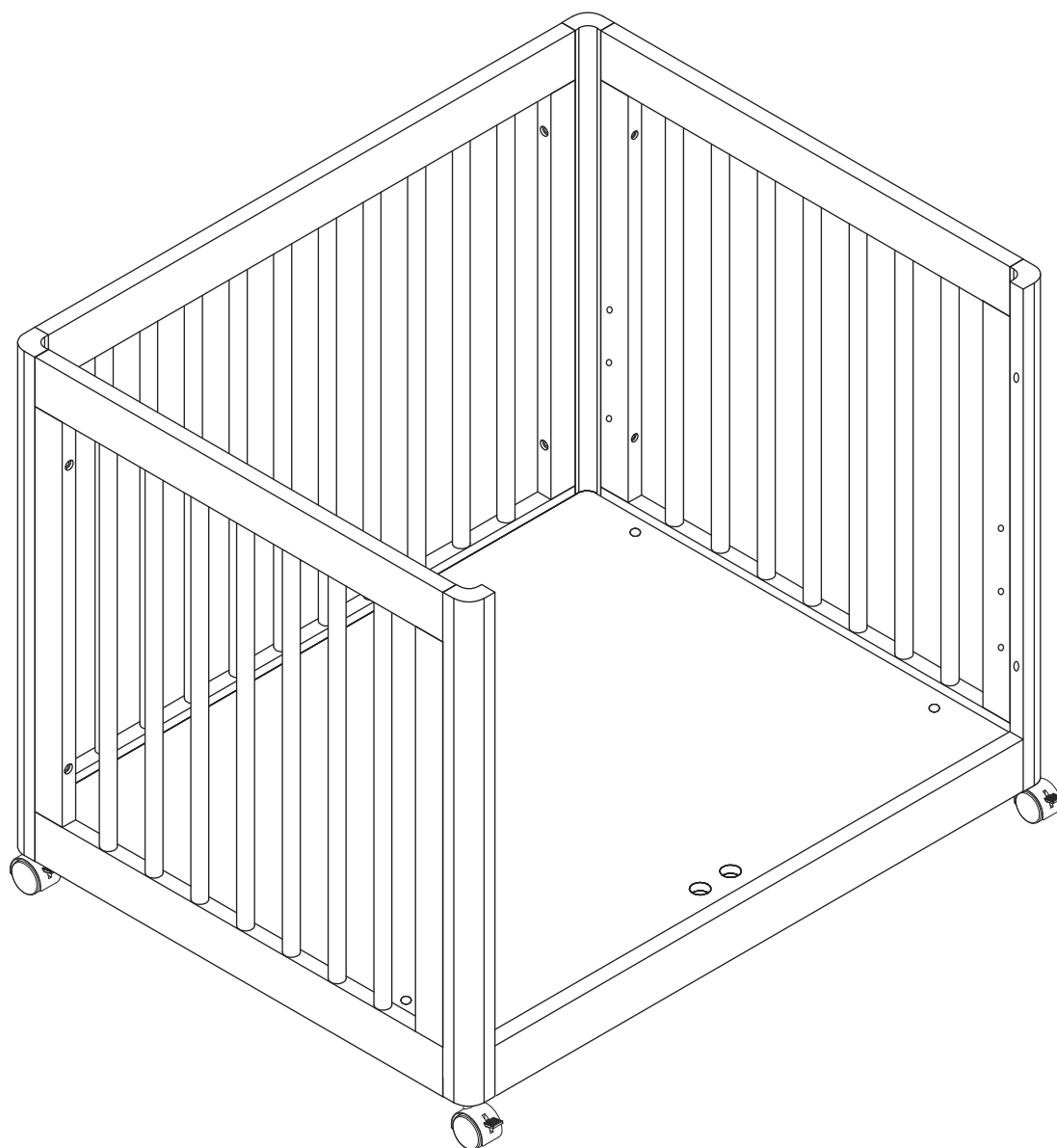

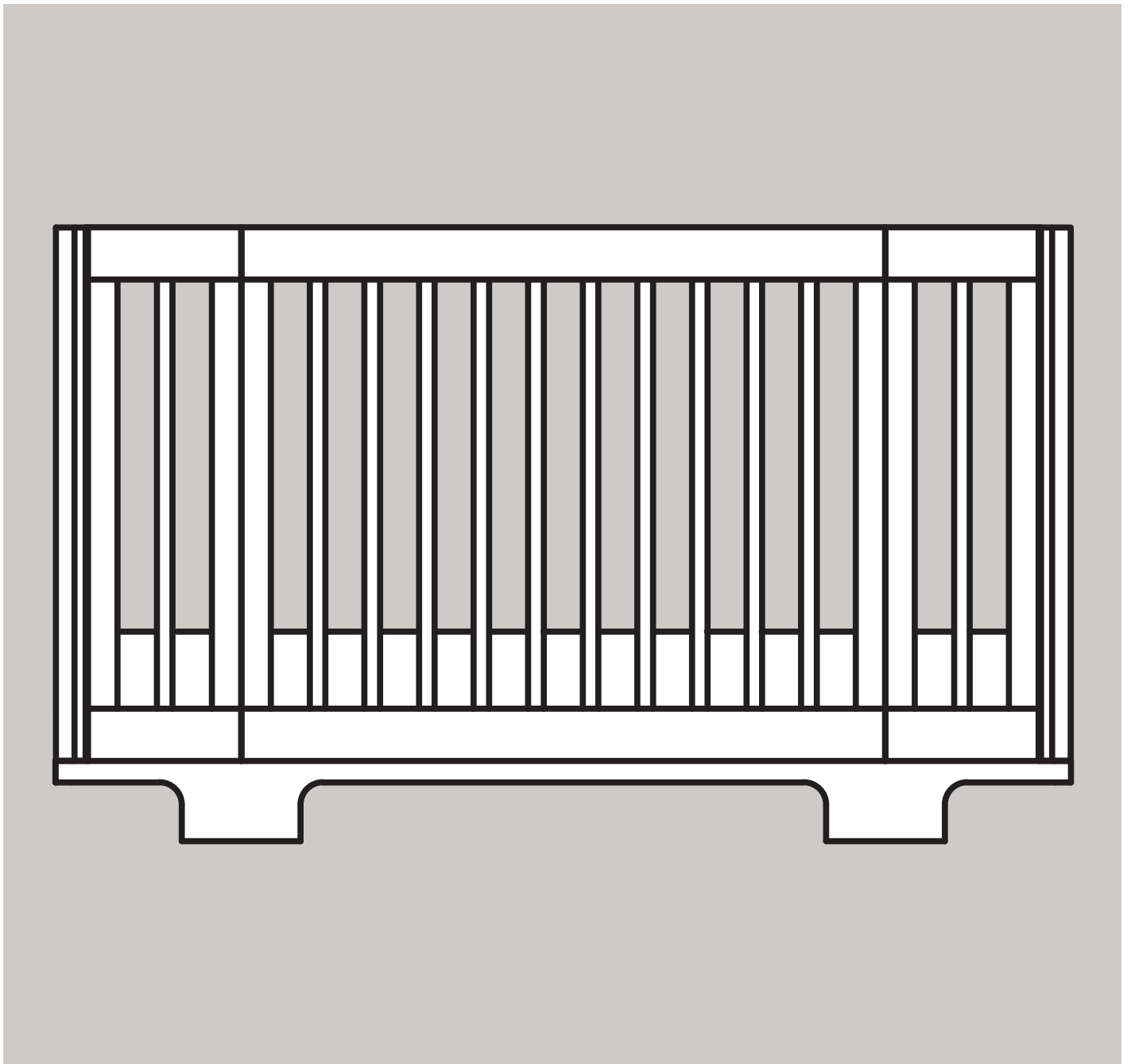

# Yuzu™ Crib

M23401

 babyletto

**parts**

not to scale

**piezas**

no a escala

**pièces**

non dessinées à l'échelle

(for crib

• para cuna

• pour lit de bébé)

**A**  
x2

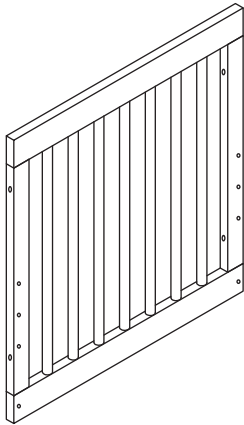

SIDE PANEL  
PANEL LATERAL  
PANNEAU LATÉRAL

**B**  
x2

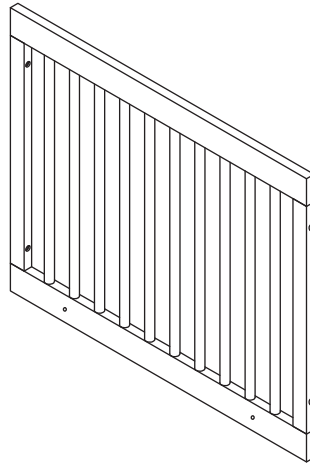

FRONT / BACK PANEL  
PANEL FRONTAL / POSTERIOR  
PANNEAU AVANT / ARRIÈRE

**C**  
x2

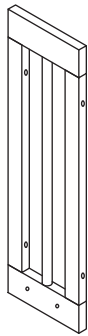

SMALL LEFT SIDE PANEL  
PANEL LATERAL IZQUIERDO PEQUEÑO  
PETIT PANNEAU LATÉRAL GAUCHE

**D**  
x2

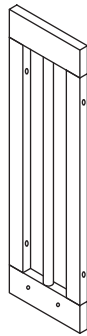

SMALL RIGHT SIDE PANEL  
PANEL LATERAL DERECHO PEQUEÑO  
PETIT PANNEAU LATÉRAL DROIT

**E**  
x2

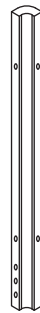

LEFT POST  
PIE IZQUIERDO  
PIED GAUCHE

**F**  
x2



RIGHT POST  
PIE DERECHO  
PIED DROIT

**L**  
x2

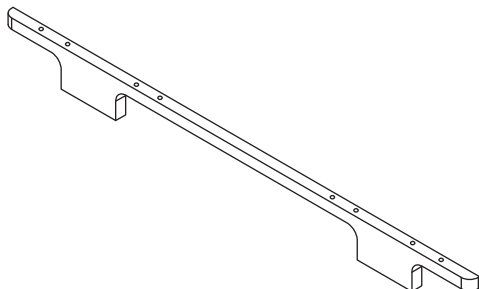

LONG BASE FRAME RAIL  
RIEL DE MARCO DE BASE LARGA  
TRAVERSE LONGUE DE LA BASE

**M**  
x2

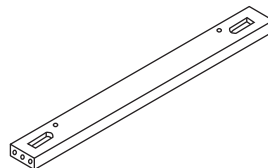

SHORT BASE FRAME RAIL  
RIEL DE MARCO BASE CORTO  
TRAVERSE COURTE DE LA BASE

R

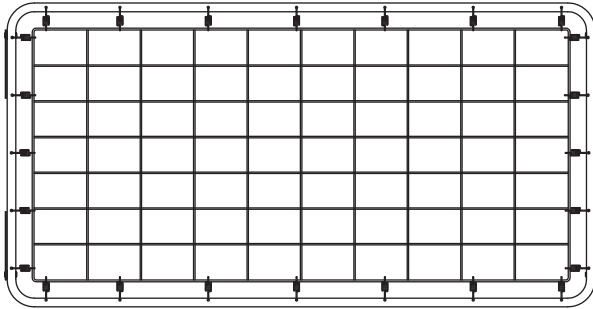

MATTRESS SUPPORT IV  
SOPORTE DE COLCHÓN IV  
SUPPORT DU MATELAS IV

for toddler bed conversion  
para conversión de cama bebé que ya camina  
pour conversion de lit pour tout-petit

K

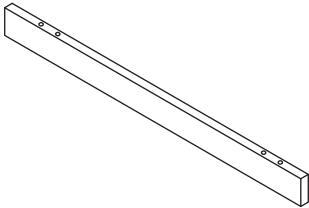

BACK BOTTOM CROSS BAR  
BARRA TRANSVERSAL TRASERA INFERIOR  
BARRE TRANSVERSALE INFÉRIEURE ARRIÈRE

for junior bed conversion  
para conversión de cama junior  
pour la conversion en lit de junior

J

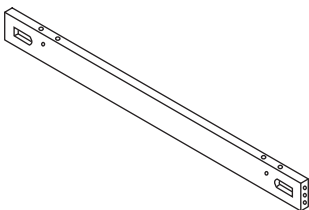

FRONT BOTTOM CROSS BAR  
BARRA TRANSVERSAL DELANTERA INFERIOR  
BARRE TRANSVERSALE INFÉRIEURE AVANT

K

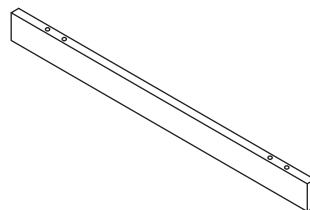

BACK BOTTOM CROSS BAR  
BARRA TRANSVERSAL TRASERA INFERIOR  
BARRE TRANSVERSALE INFÉRIEURE ARRIÈRE



hardware  
actual size

herraje  
tamaño real

matériel  
taille actuelle

(for crib · para cuna · pour lit de bébé)

H1

x4

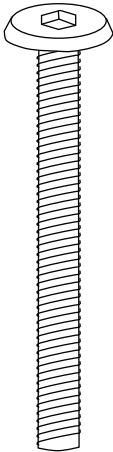

2-1/4" AHBwBN

H2

x8

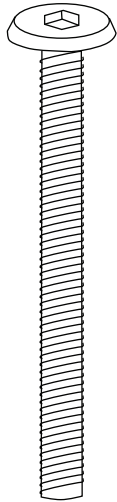

2-1/2" AHB

H3

x16

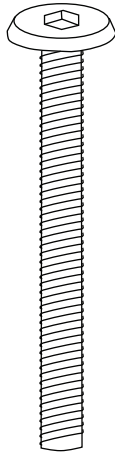

2-1/4" AHB

H4

x12

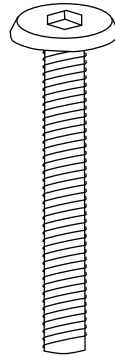

1-3/4" AHB

H6

x8

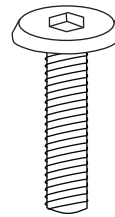

1" AHB

H7

x4

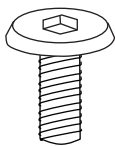

5/8" AHB

H8

x4

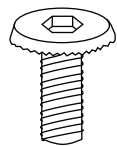

5/8" AHBS

H9

x40



LW

H10

x18

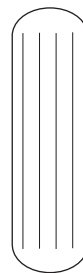

1\*3.5 WD

H11

x8

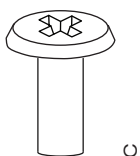

H12

x4

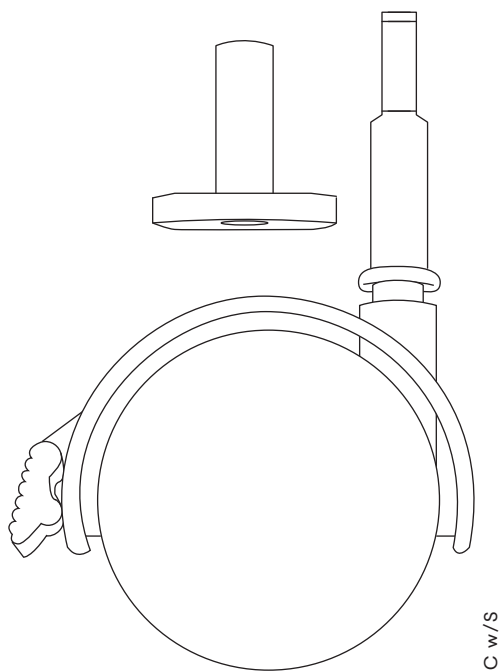

H13

x1

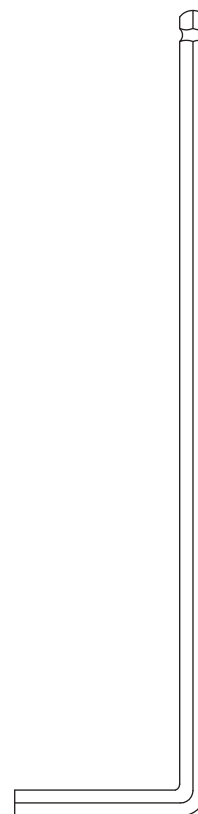

AWR

- \* KEEP THE ALLEN WRENCH FOR FUTURE USE.
- \* GUARDE LA LLAVE ALLEN PARA USO FUTURO.
- \* CONSERVER LA CLÉ ALLEN POUR UN USAGE ULTÉRIEUR.

1

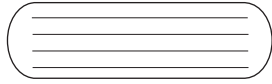

H10  
x8

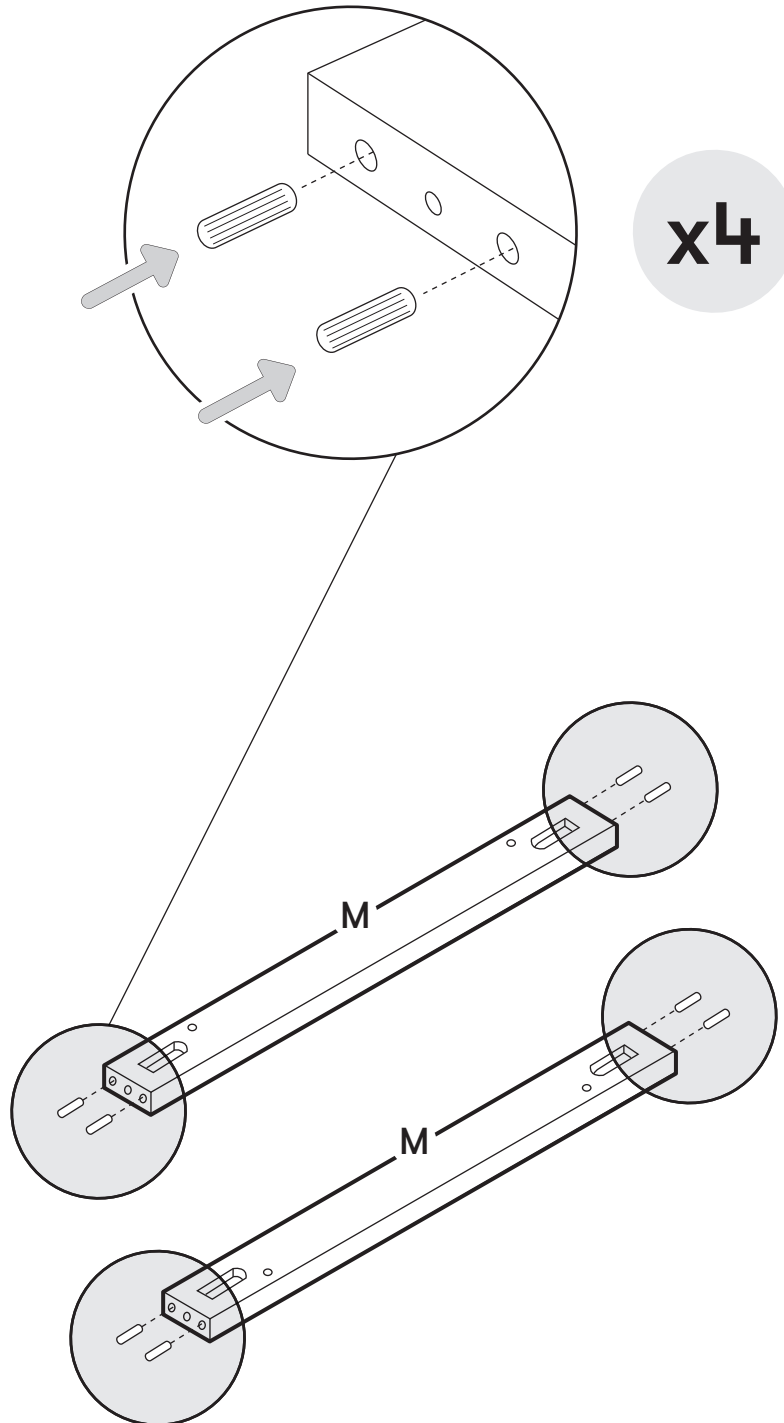

2

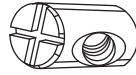
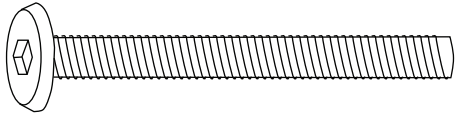

H1  
x4



H9  
x4

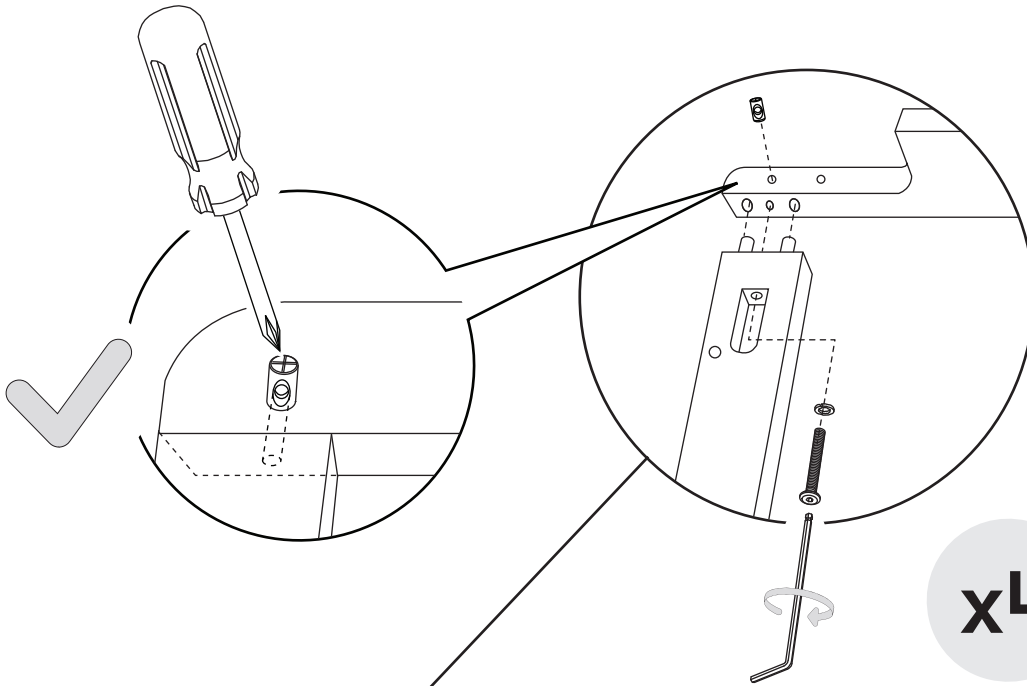

x4

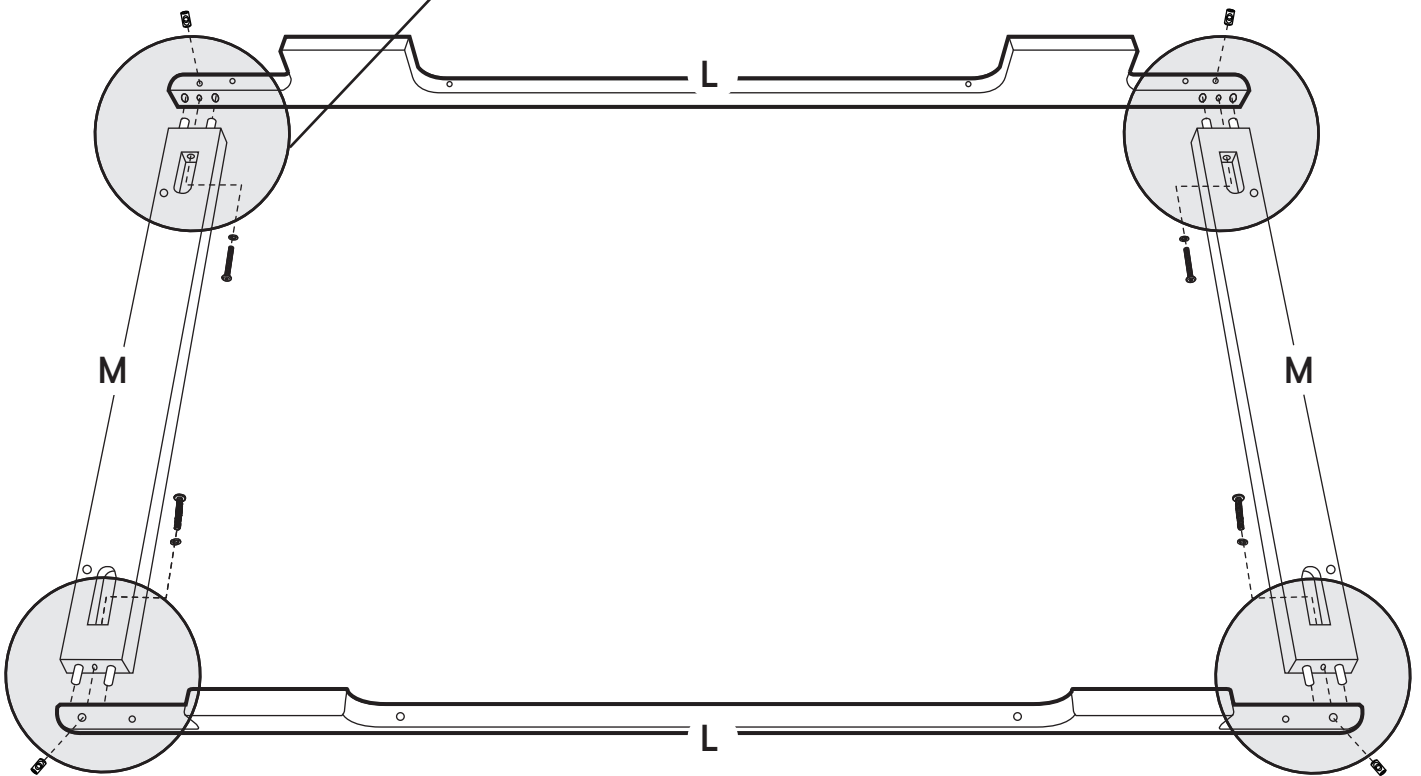

3

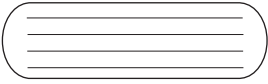

H10  
x10

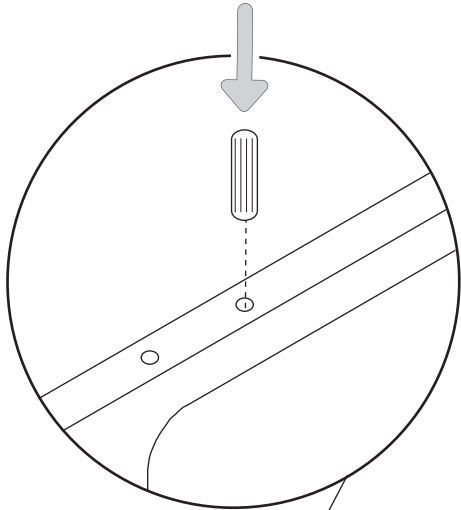

x10

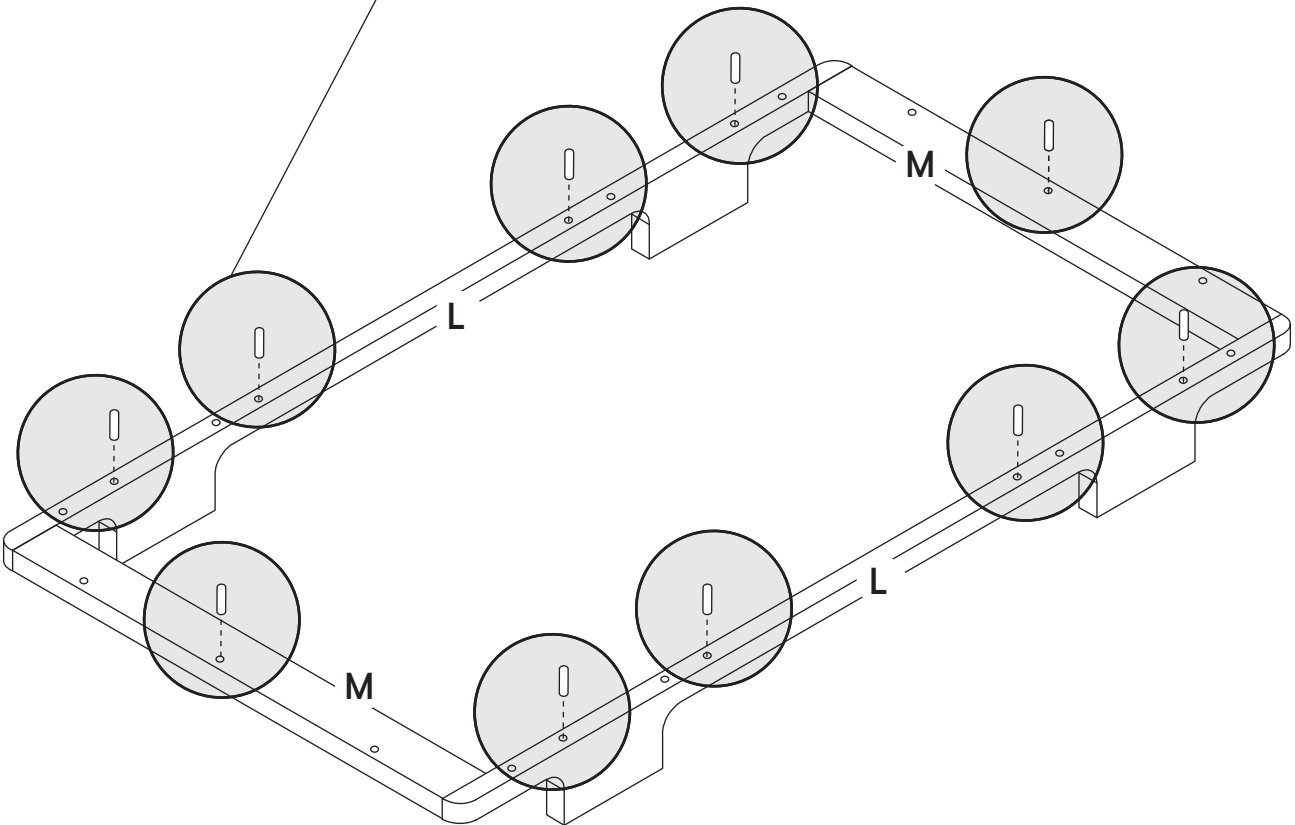

4

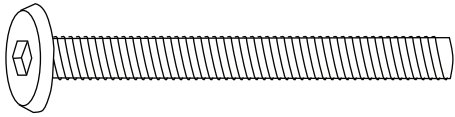

H3  
x8



H9  
x8

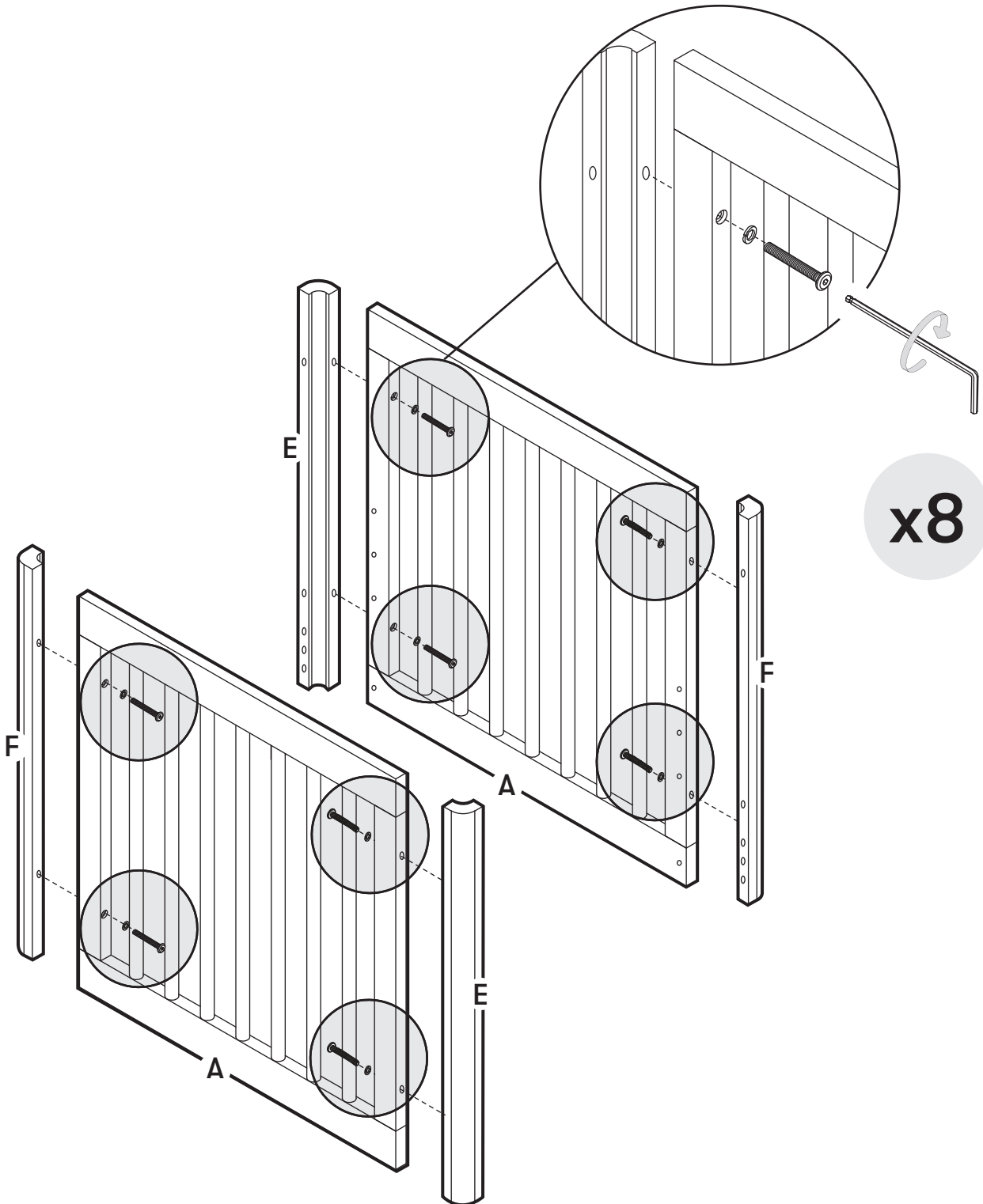

x8

5

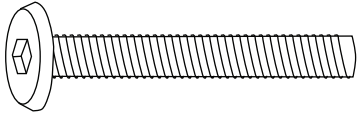

H4  
x4



H9  
x4

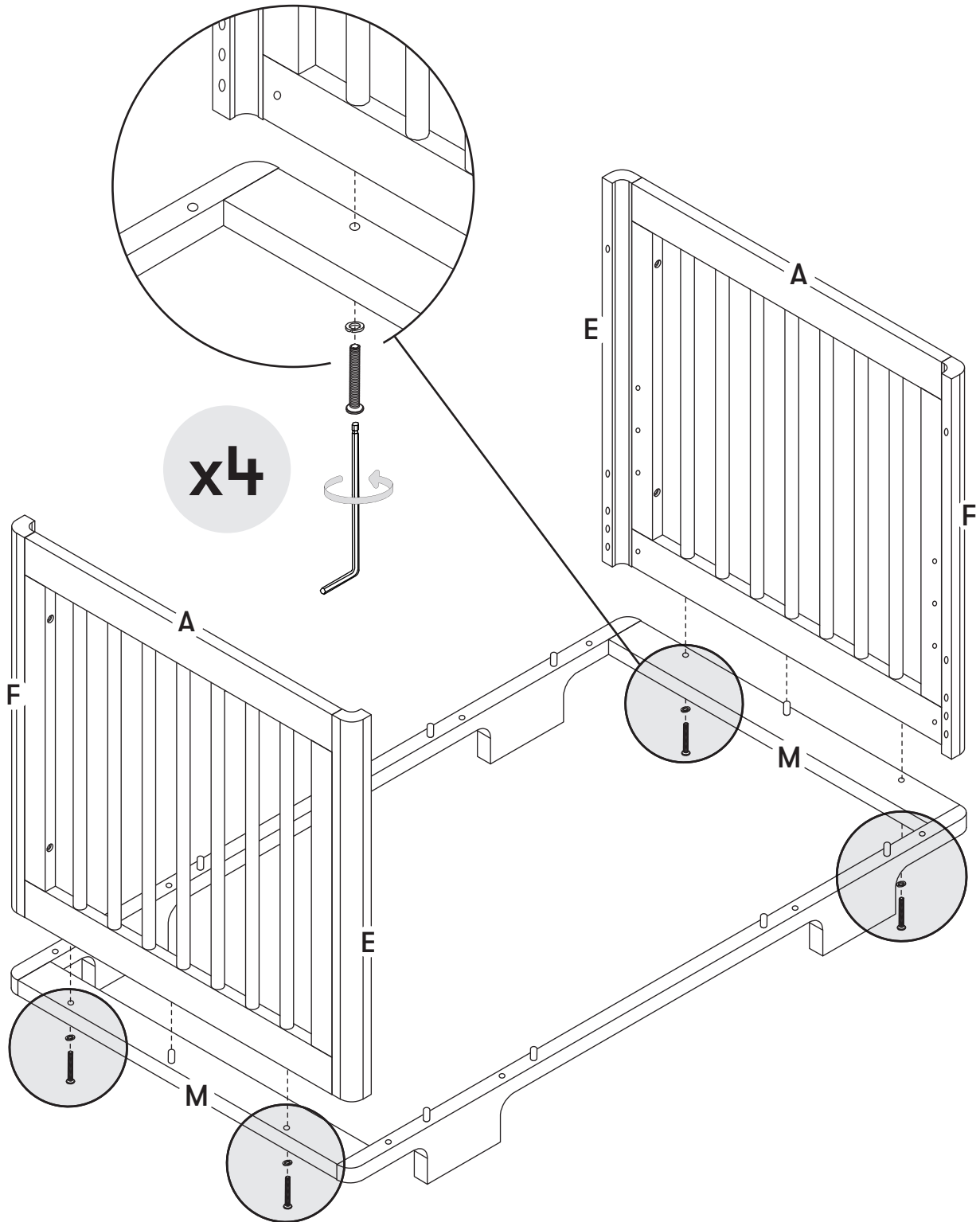

6

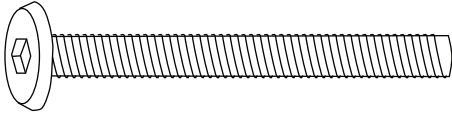

H3  
x4



H9  
x4

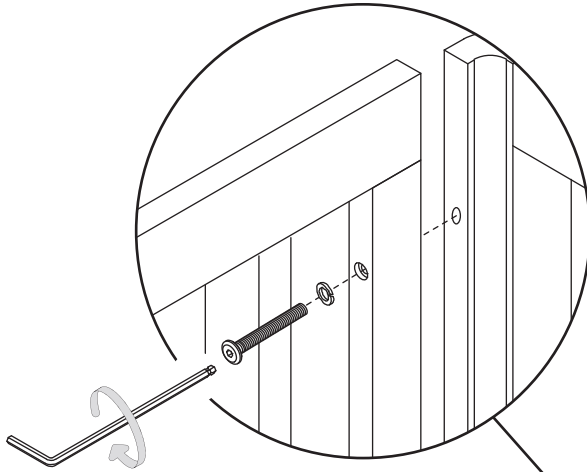

x4

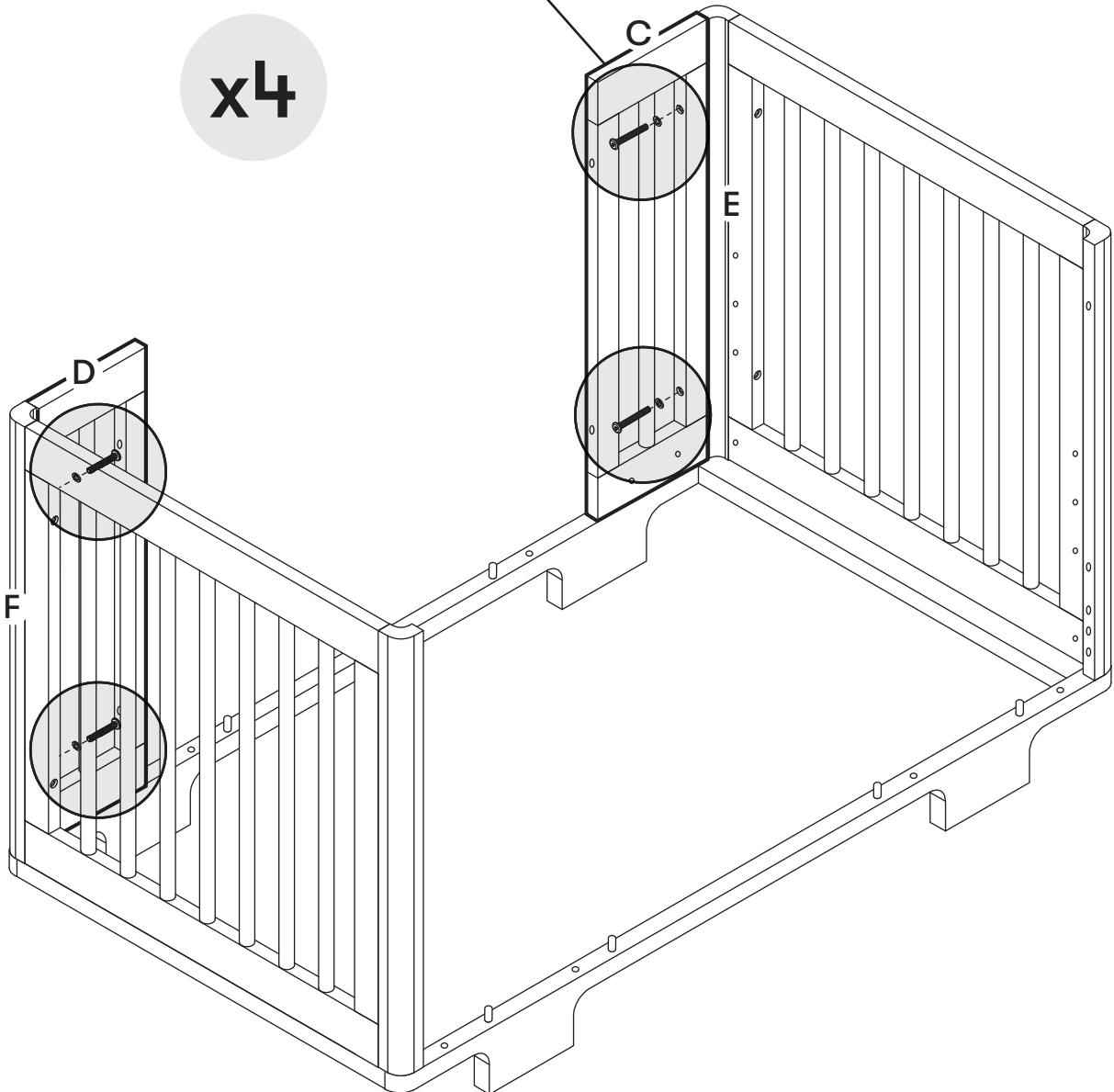



7

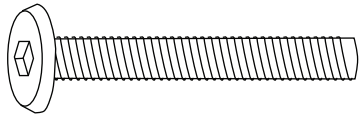

H4  
x2



H9  
x2

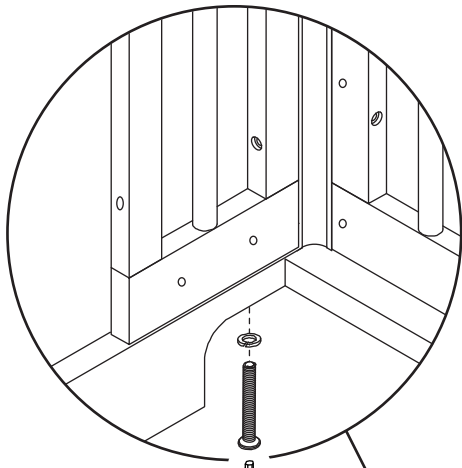

x2

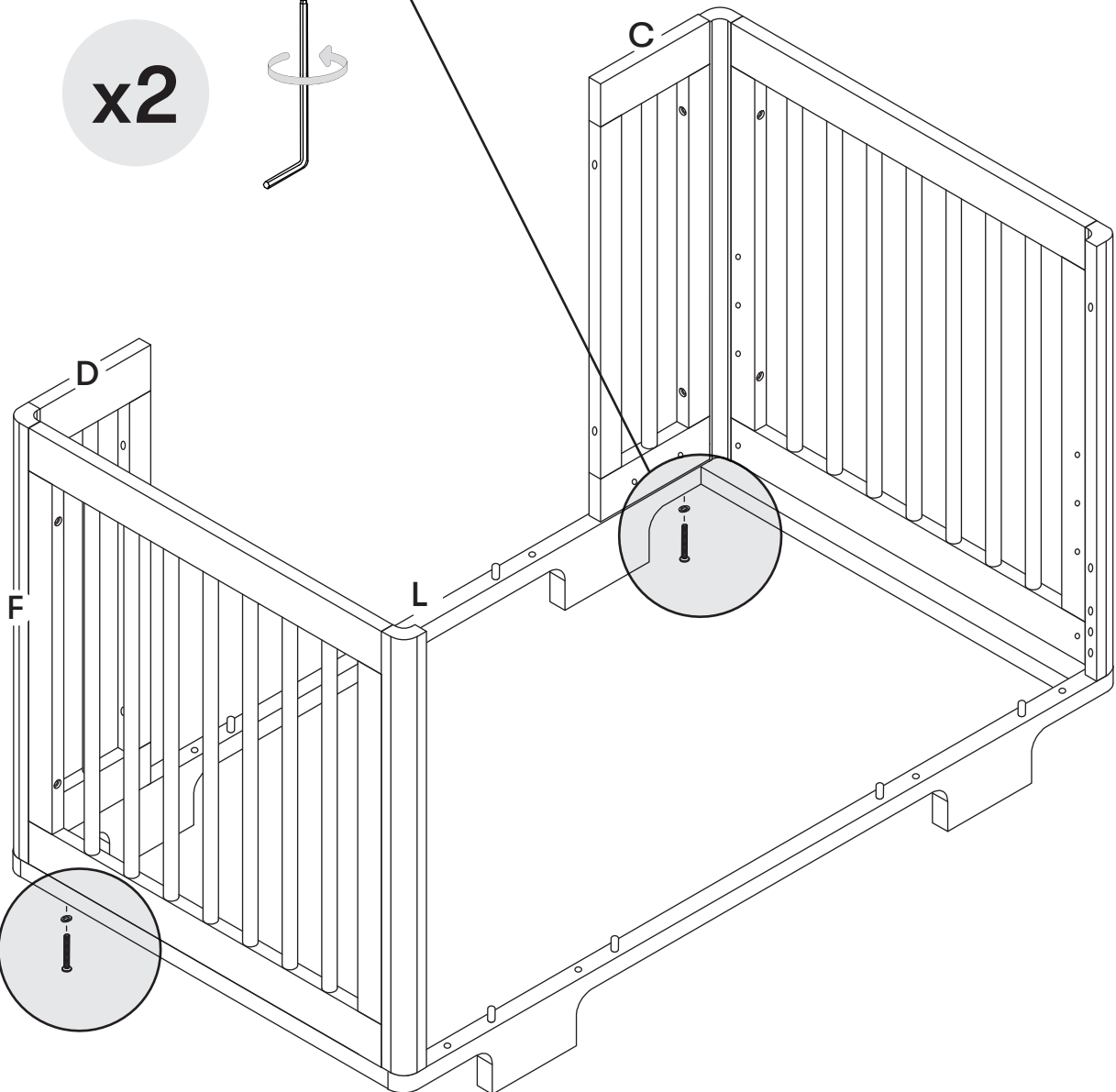
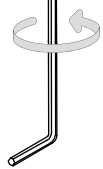

8

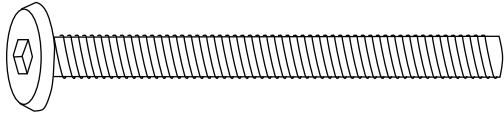

H2  
x4



H9  
x4

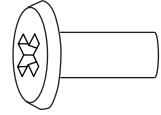

H11  
x4

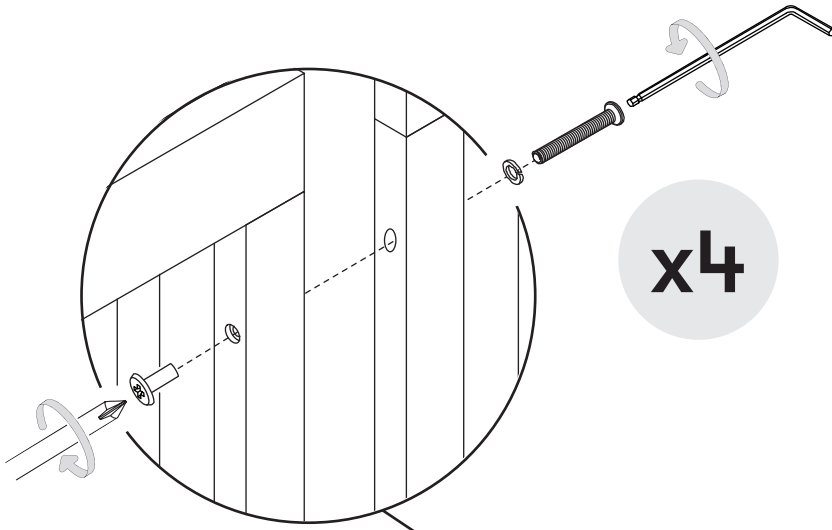

x4

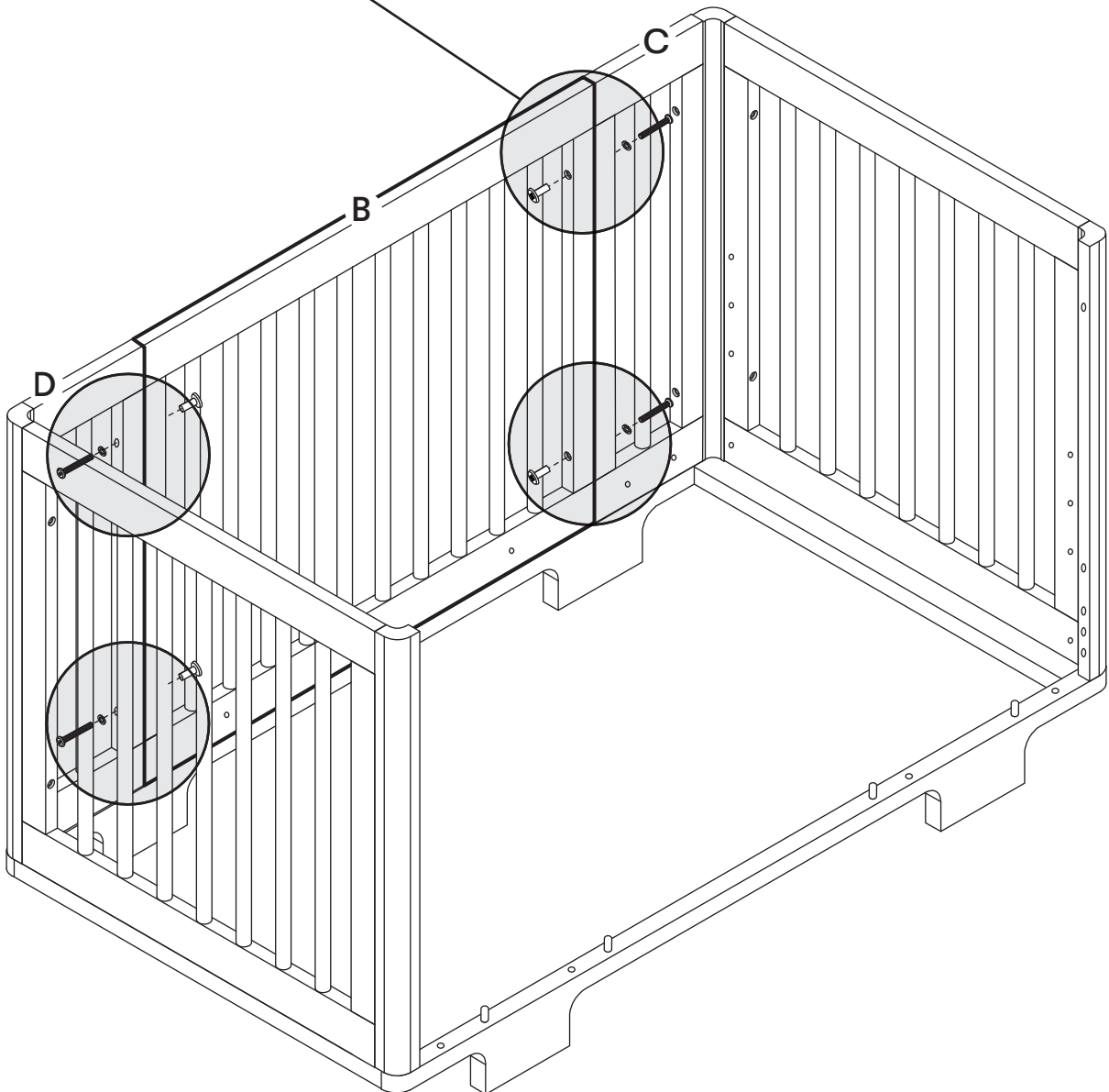

9

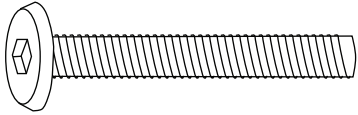

H4  
x2



H9  
x2

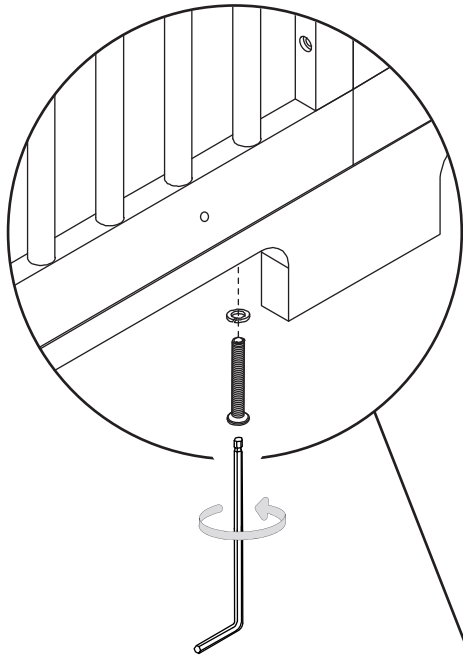

x2

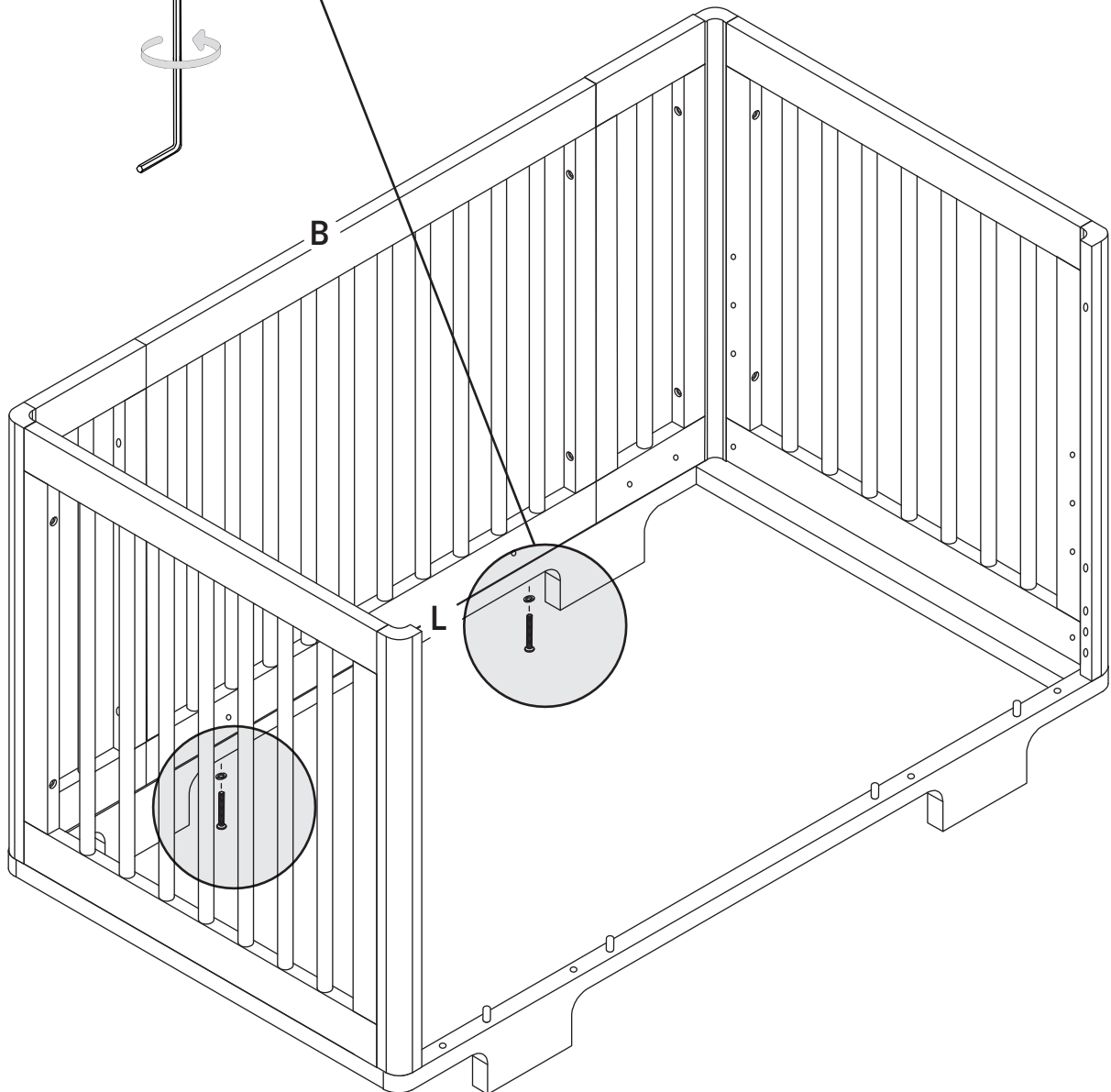

10

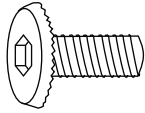

H8  
x4

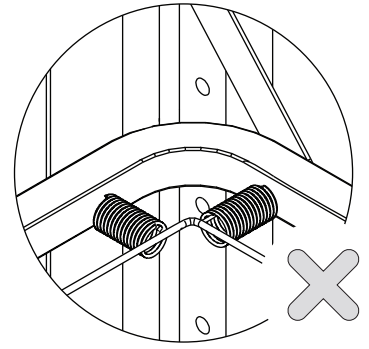
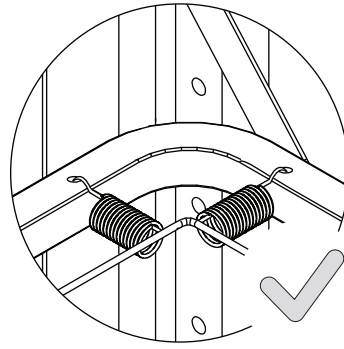

x4

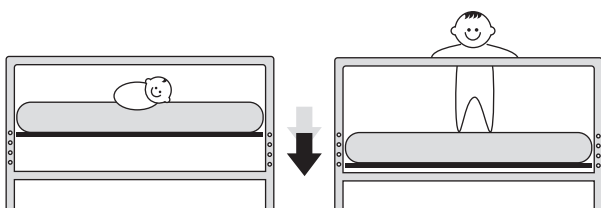
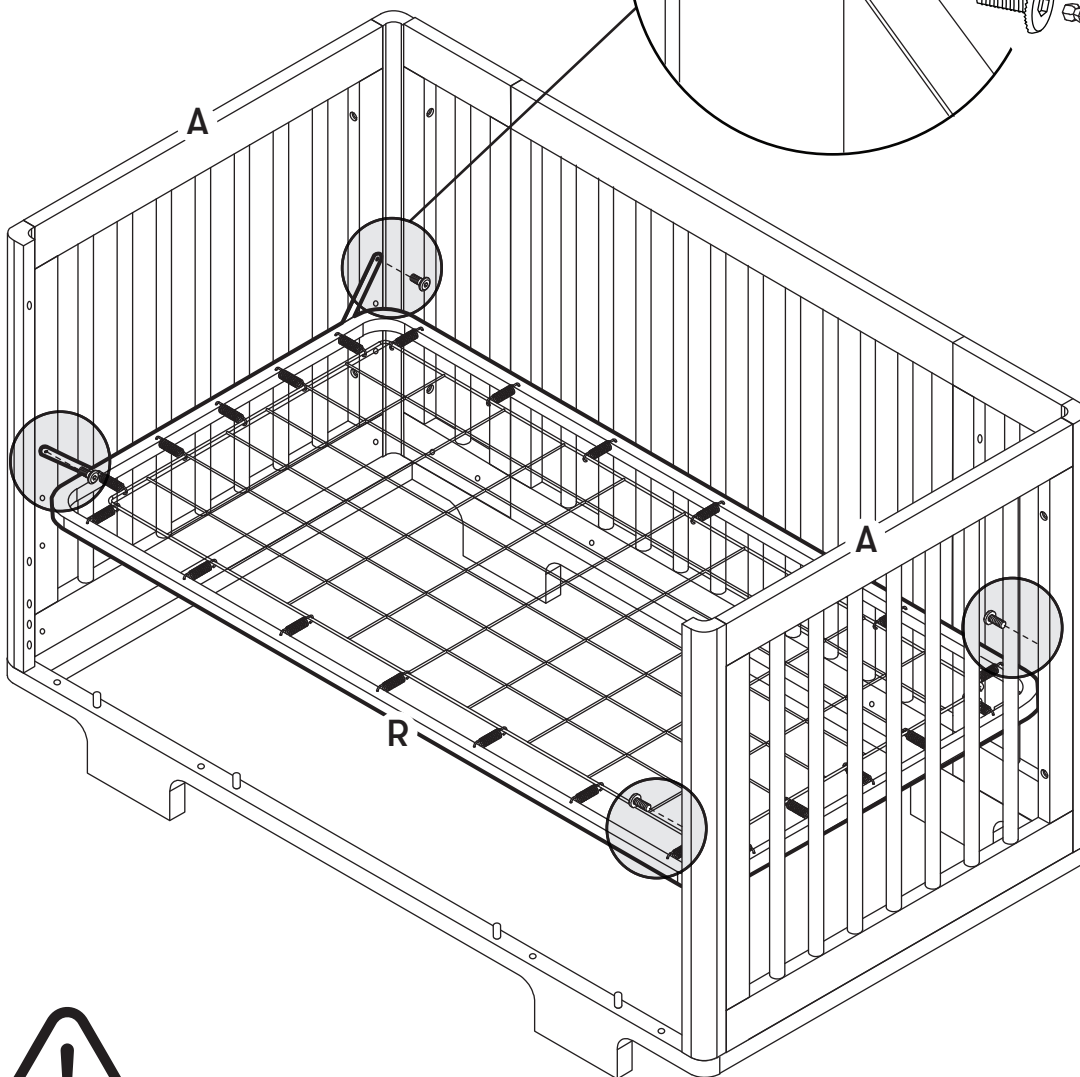
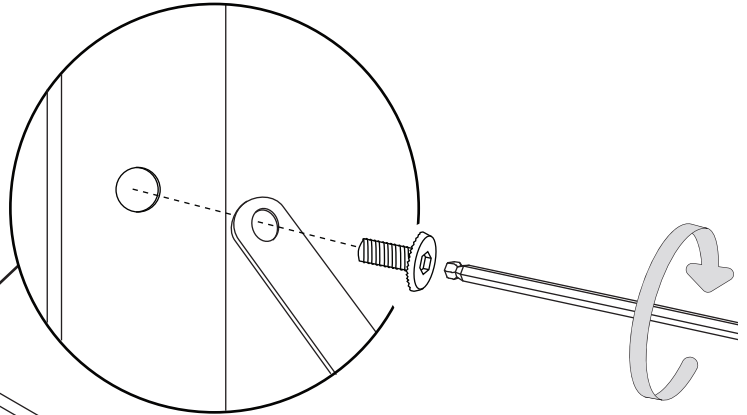

Lower the support as your child grows.

Baje el soporte a medida que vaya creciendo el niño.

Abaissez le support à mesure que votre enfant grandit.

11

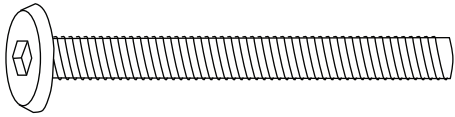

H3  
x4



H9  
x4

x4

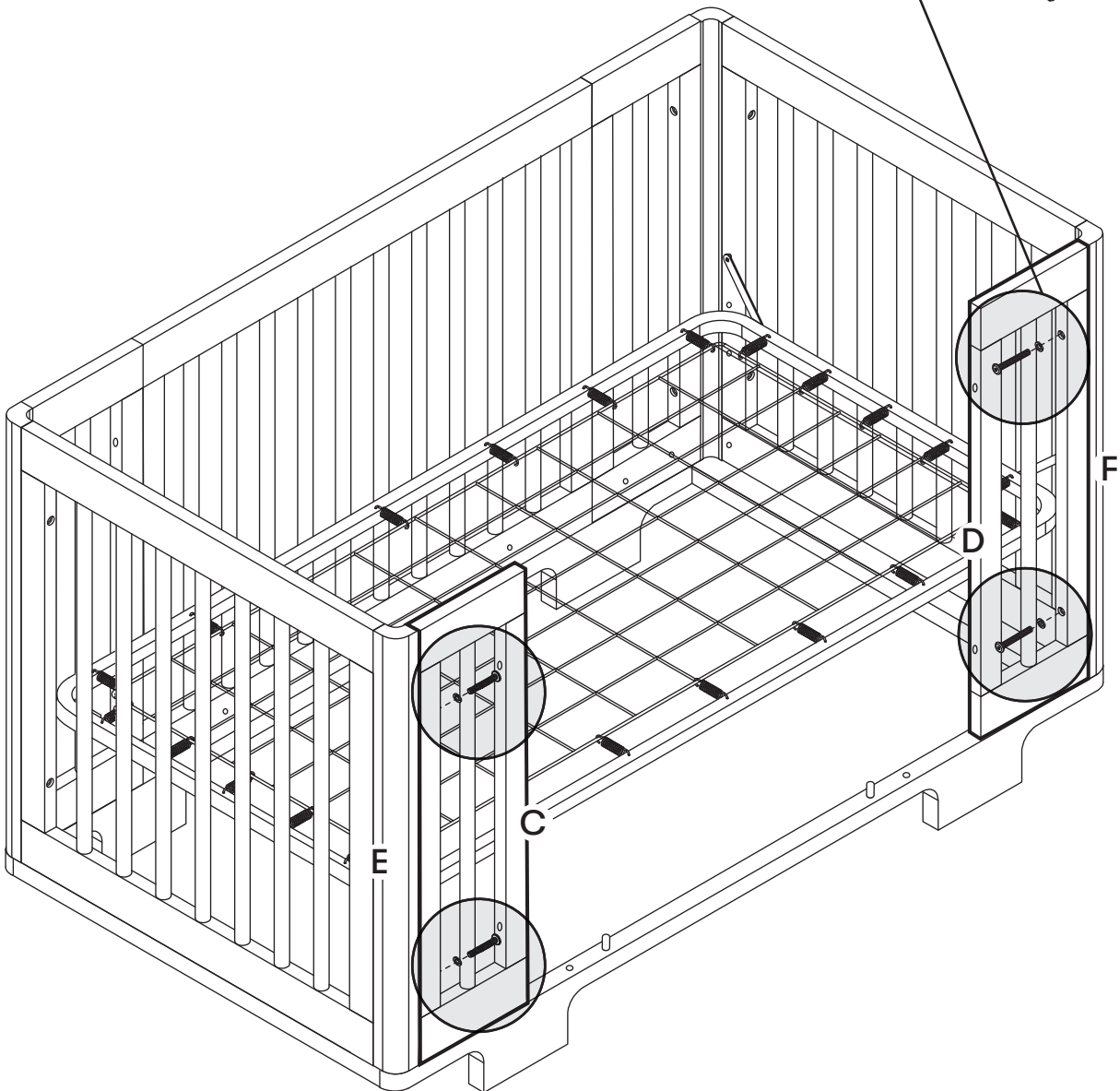
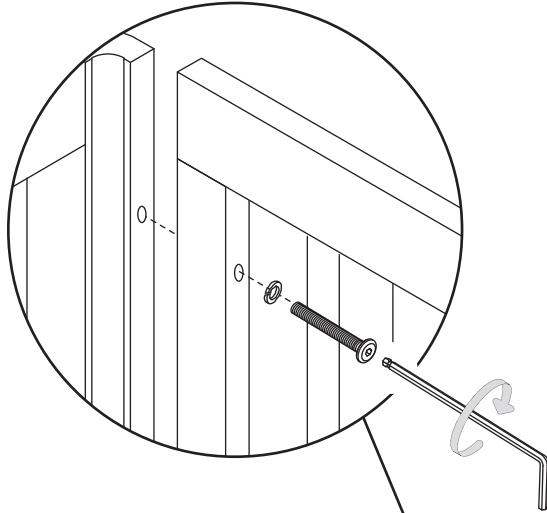

12

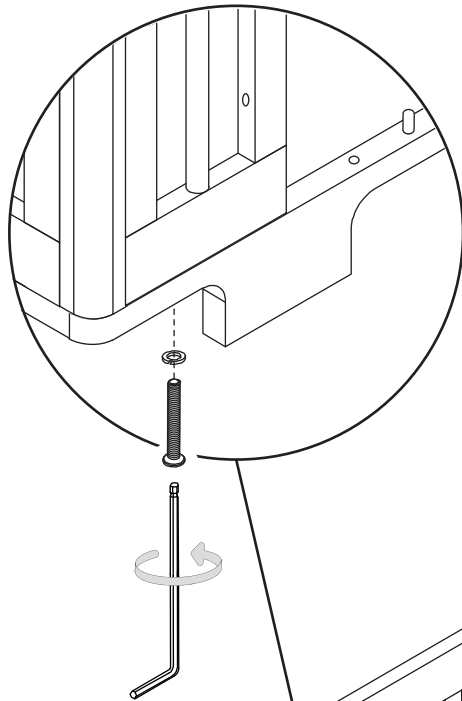
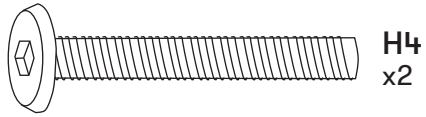

x2

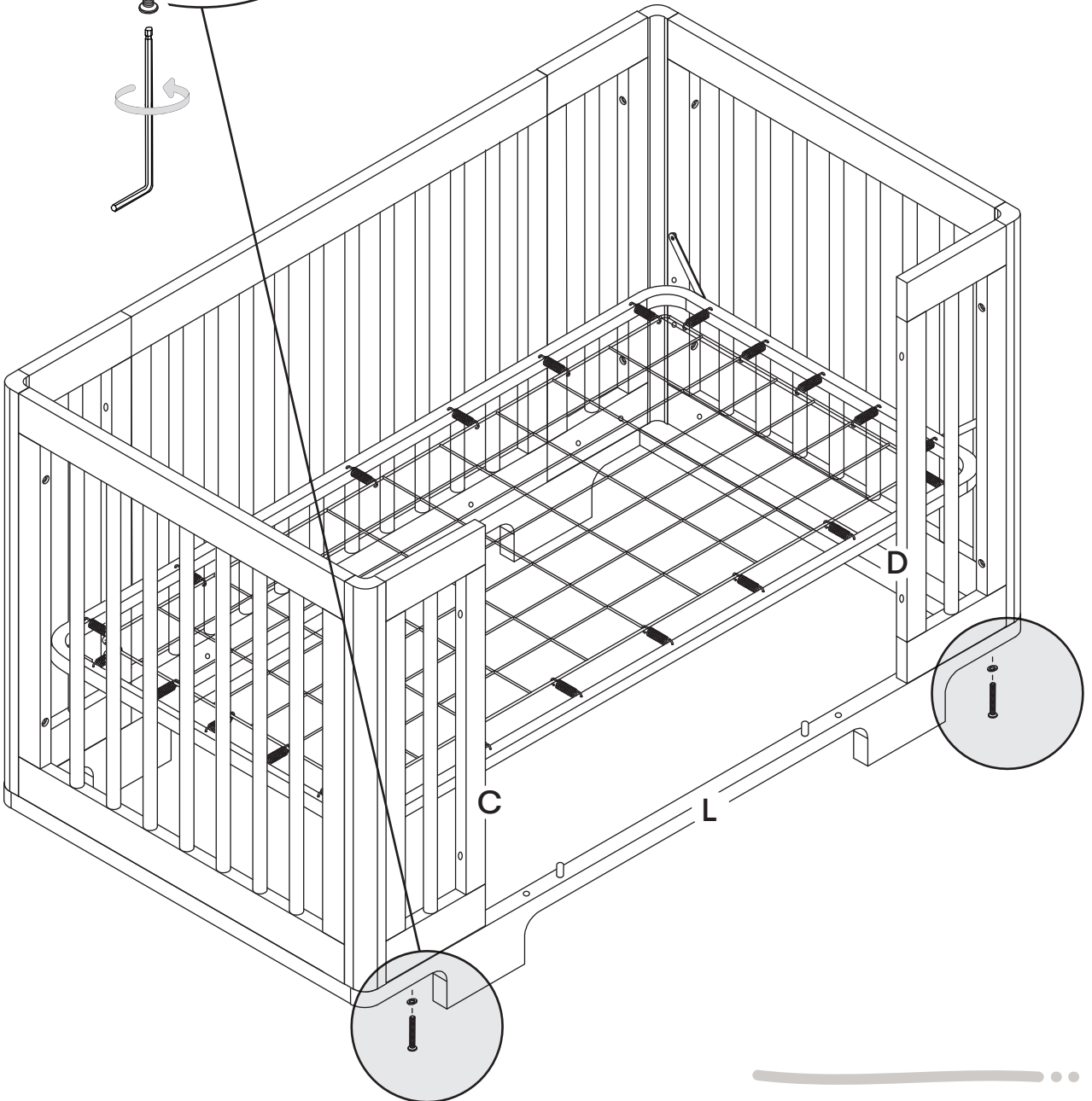

13

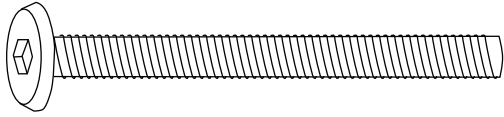

H2  
x4



H9  
x4

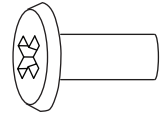

H11  
x4

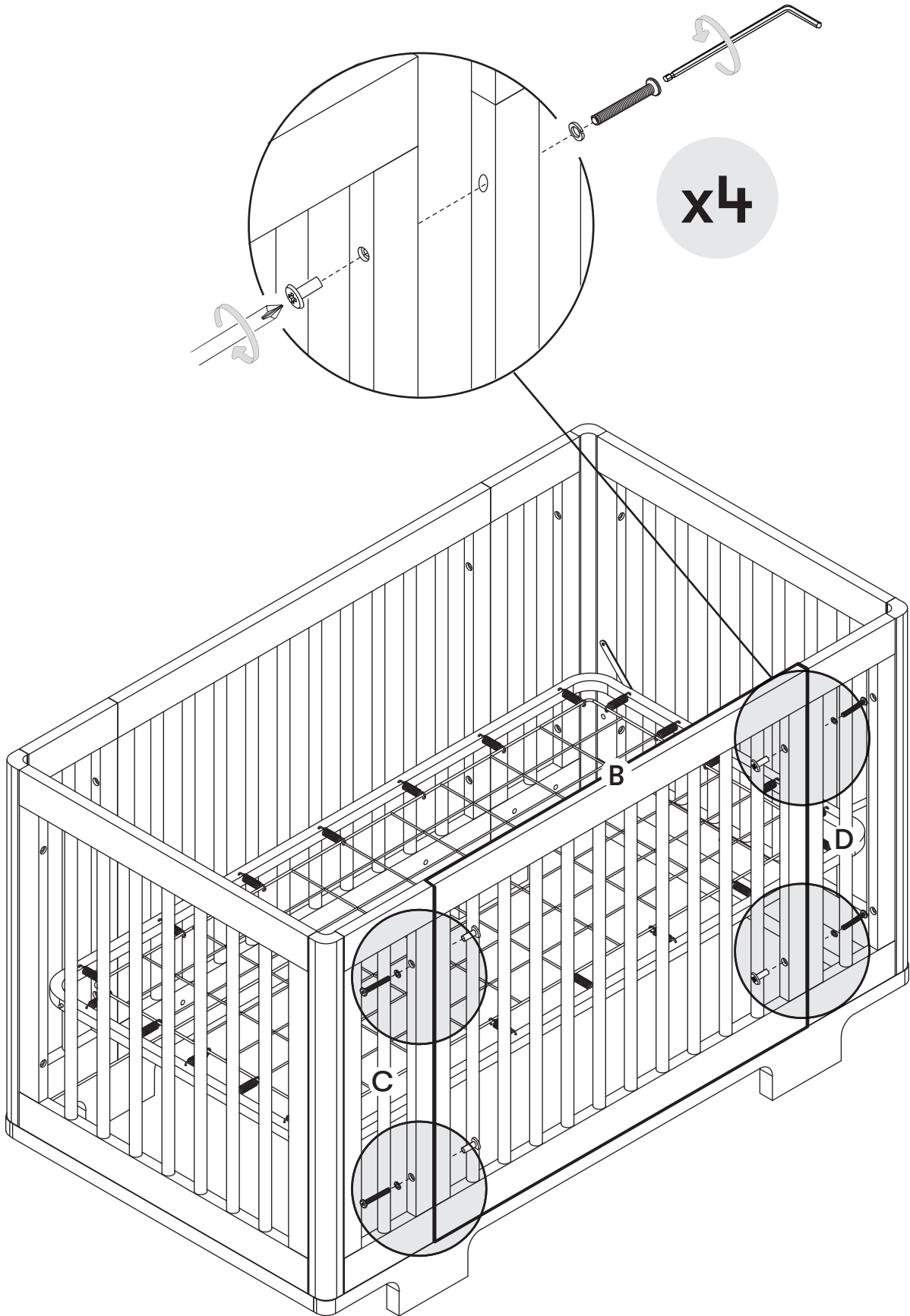

14

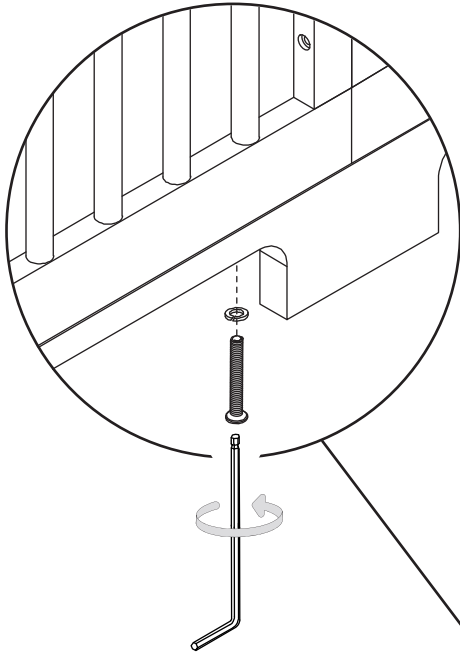
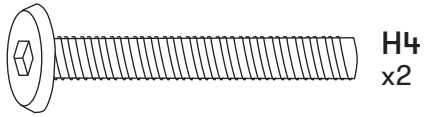

x2

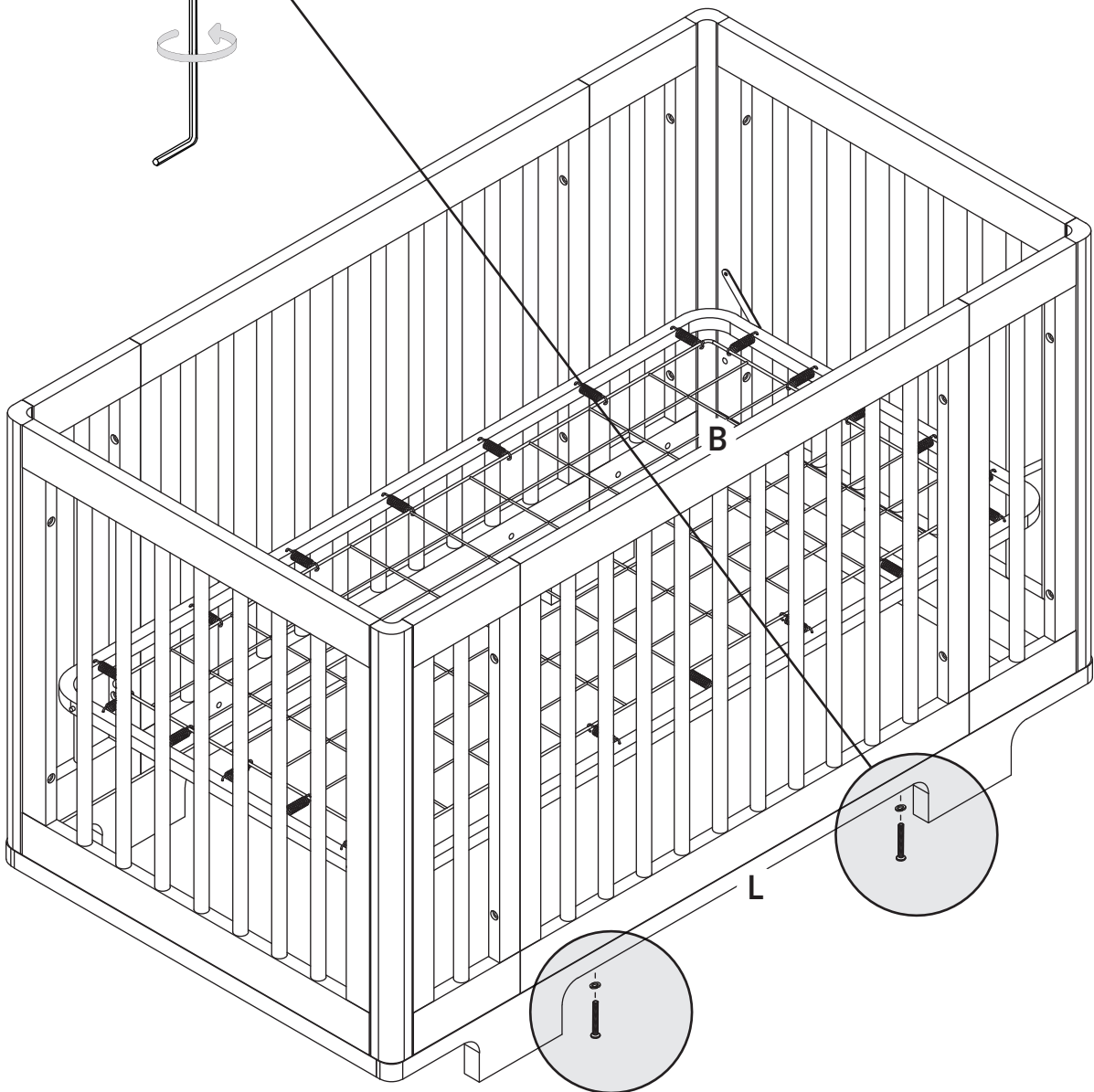



*Voilà!*

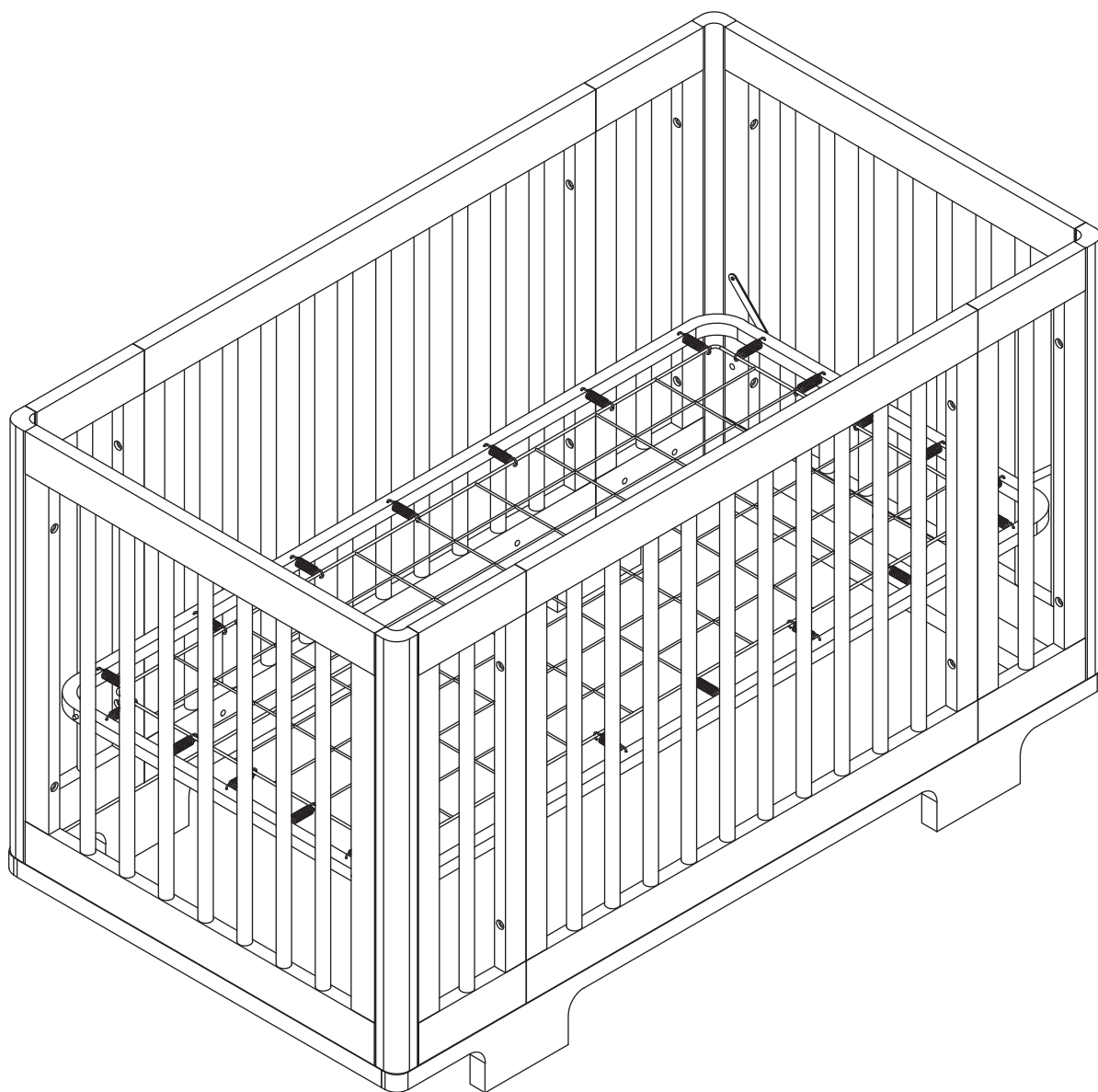

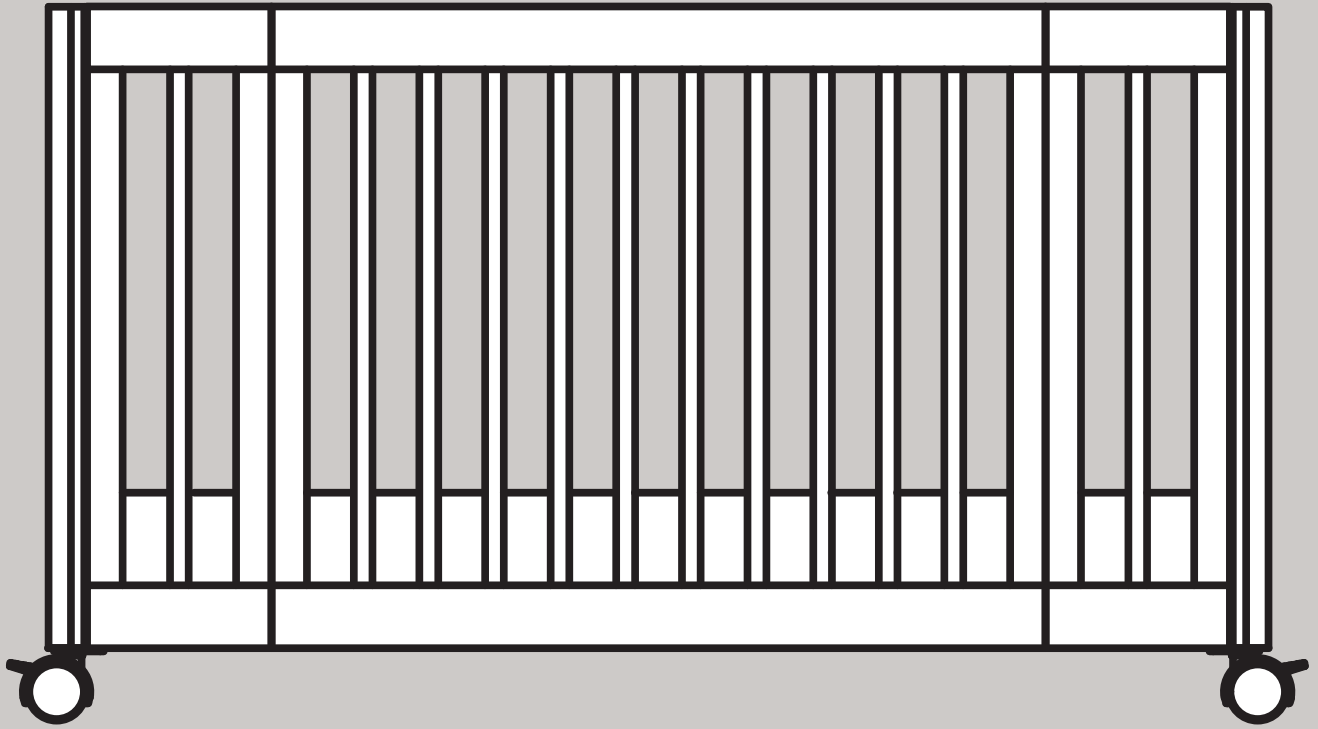

# Optional

M23401

1

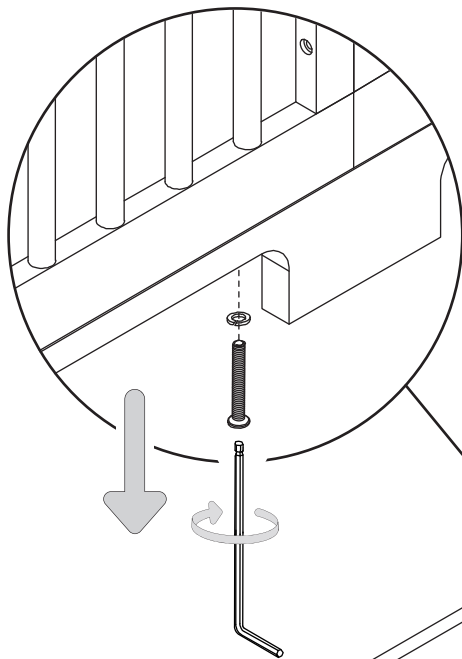
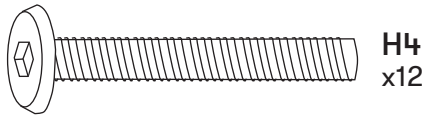

x12

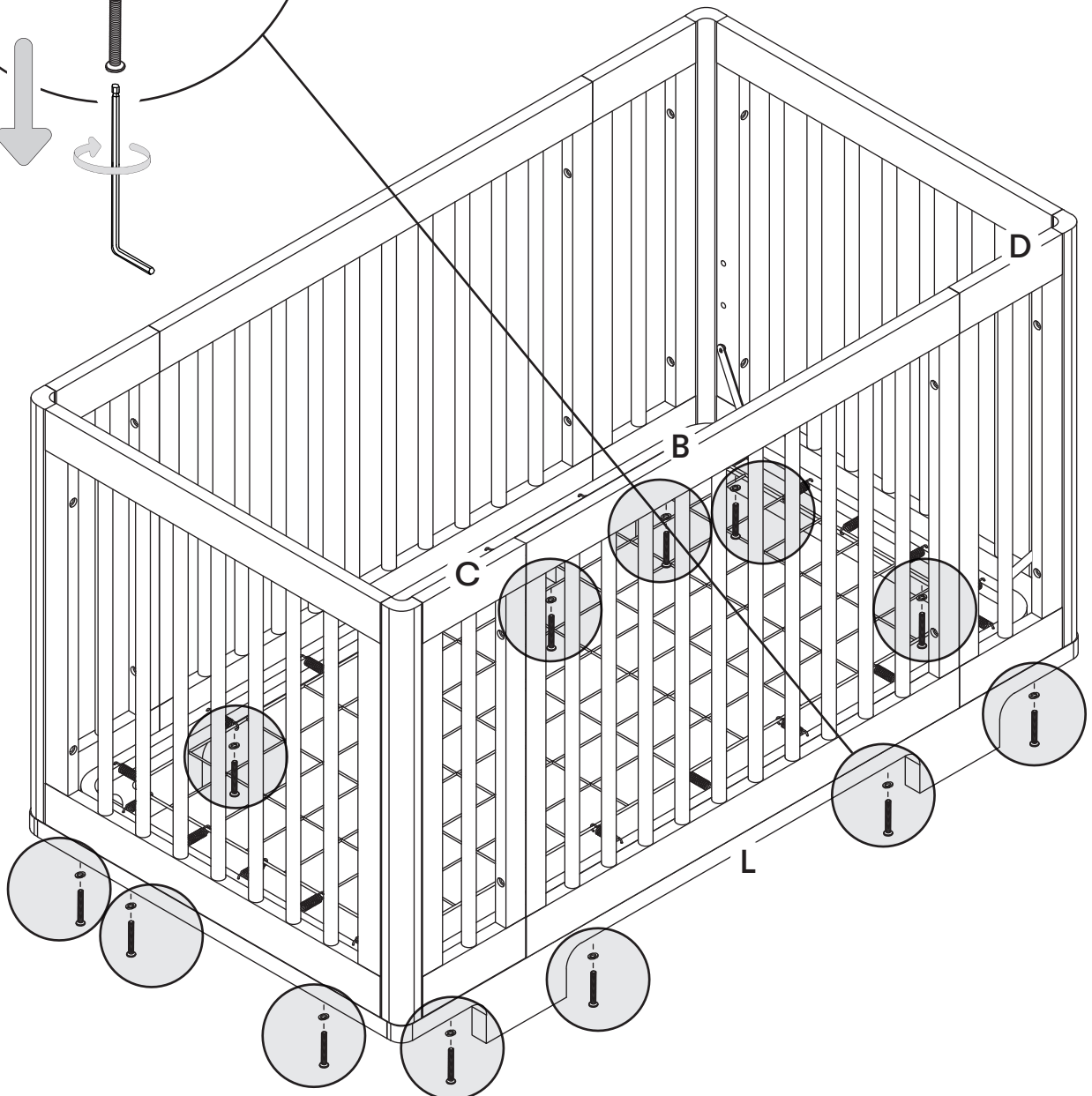

2

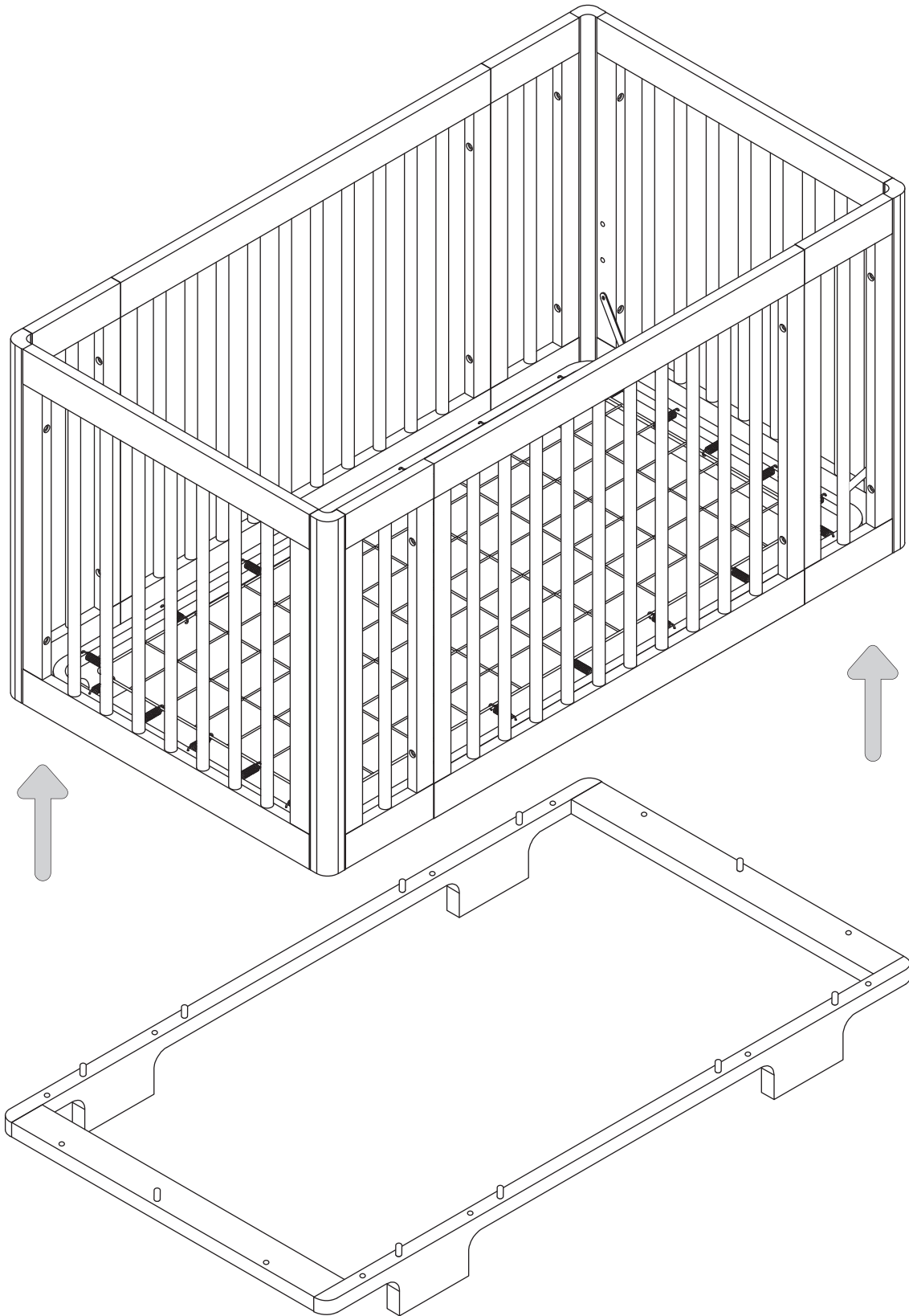

3

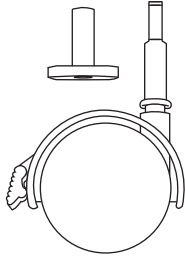

H12  
x4

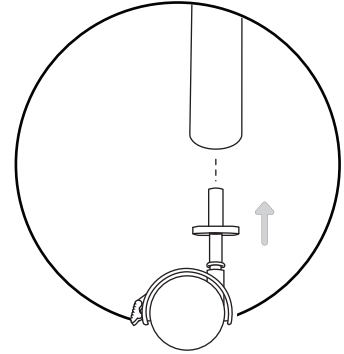
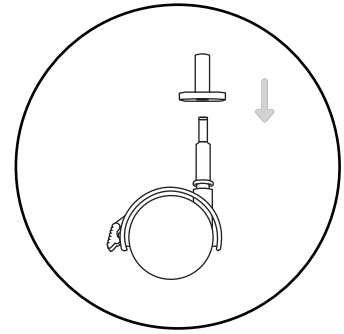

- \* Tighten firmly until the casters snap into place.  
Be sure the casters can turn freely.
- \* Apretar firmemente hasta que las ruedas encajen con un chasquido en su lugar.  
Revisar que las ruedas puedan girar libremente.
- \* Qu'ils de ce jusqu'à de fermement d'appuyer rentrer de jeu de caractères. Être sur que les casters peut tourner librement.

x4

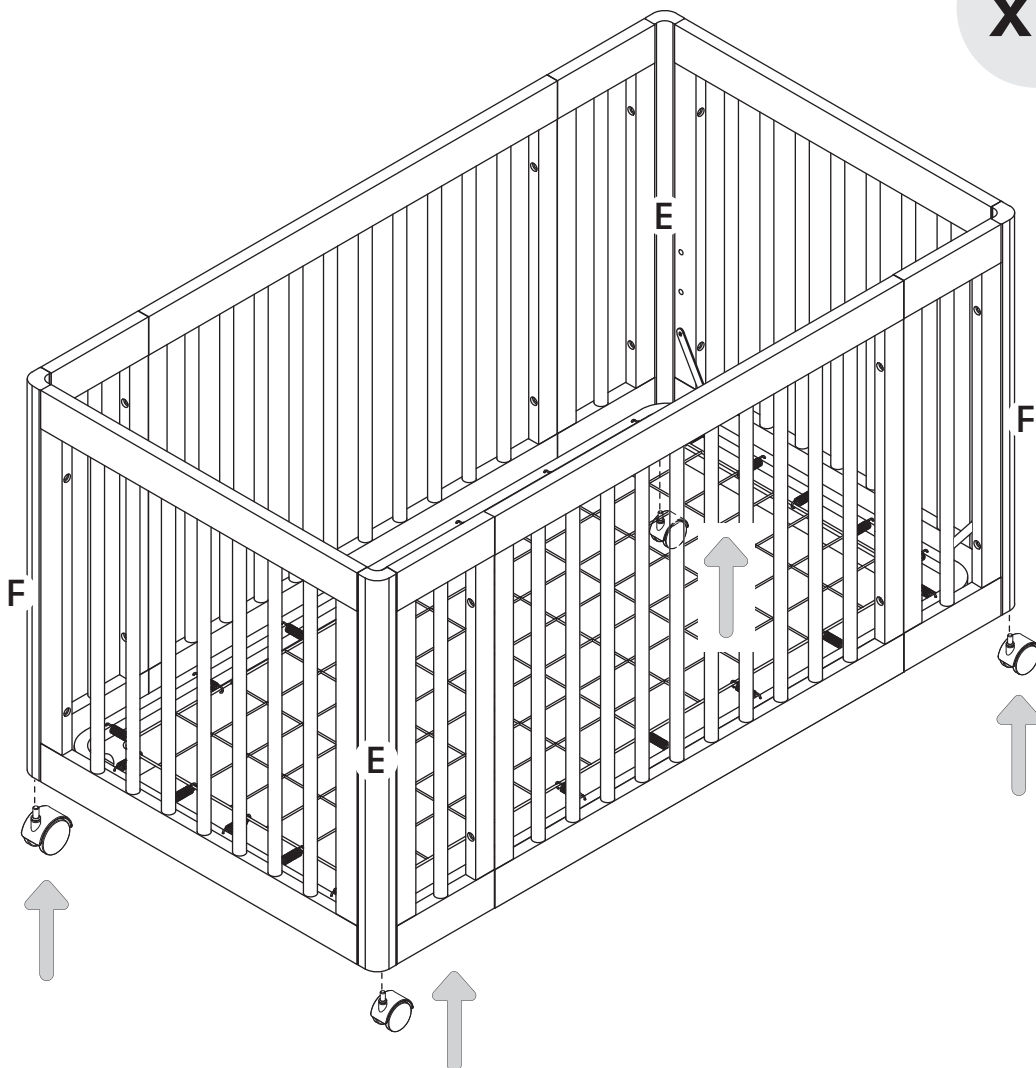

*Voilà!*

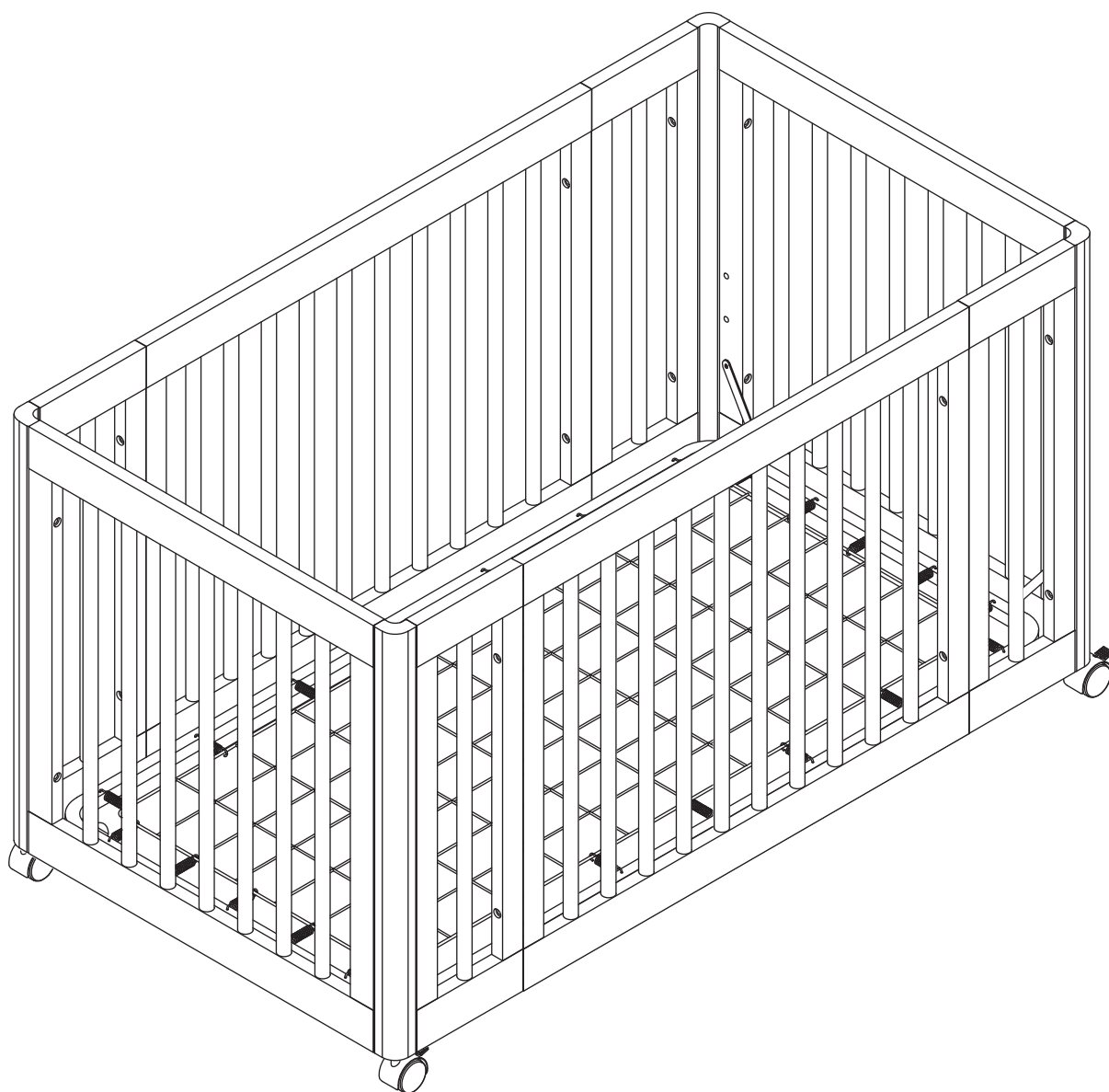

## **⚠️ WARNING**

### **⚠️ WARNING:**

Failure to follow these warnings and the assembly instructions could result in serious injury or death.

#### **BEFORE ASSEMBLY**

Read all instructions before assembling crib. Keep instructions for future use.

Check this product for damaged hardware, loose joints, loose bolts or other fasteners, missing parts, or sharp edges before and after assembly and frequently during use. Securely tighten loose bolts and other fasteners.

DO NOT use crib if any parts are missing, damaged, or broken.

For replacement parts or instruction manuals, contact Million Dollar Baby Co.

#### **SUFFOCATION HAZARD**

Never use plastic shipping bags or other plastic film as mattress covers because they can cause suffocation.

Infants can suffocate in gaps between crib sides and a mattress that is too small.

### **⚠️ WARNING:**

Infants can suffocate on soft bedding. Never add a pillow or comforter. Never place additional padding under an infant.

To reduce the risk of SIDS, pediatricians recommend healthy infants be placed on their backs to sleep, unless otherwise advised by your physician.

## **CAUTION**

**ANY MATTRESS USED IN THIS CRIB MUST BE AT LEAST 27 1/4 INCHES (69CM) BY 51 5/8 INCHES (131CM) WITH A THICKNESS NOT EXCEEDING 6 INCHES (15CM).**

### **⚠️ WARNING:**

Use a mattress that is no thicker than 15 cm and is of such a size that, when it is pushed firmly against any side of this crib, it does not leave a gap of more than 3 cm between the mattress and any part of any other side of the crib.

#### **STRANGULATION HAZARD**

Strings can cause strangulation! Do not place items with a string around a child's neck, such as hood strings or pacifier cords. Do not suspend strings over a crib or attach strings to toys.

To help prevent strangulation tighten all fasteners. A child can trap parts of the body or clothing on loose fasteners.

DO NOT place crib near window where cords from blinds or drapes may strangle a child.

#### **FALL HAZARD**

When child is able to pull to a standing position, set mattress to lowest position. Remove bumper pads, large toys and other objects that could serve as steps for climbing out.

Stop using crib when child begins to climb out or reaches the height of 35 in. (89 cm).

#### **AFTER ASSEMBLY**

DO NOT substitute parts.

If refinishing, use a non-toxic finish specified for children's products.

Follow warnings on all products in a crib.

## **⚠️ ADVERTENCIA**

### **⚠️ ADVERTENCIA:**

Si no se siguen estas advertencias y las instrucciones de ensamblaje podría ocasionar lesiones serias o fatales.

#### **ANTES DEL ENSAMBLAJE**

Lea todas las instrucciones antes de ensamblar la cuna. Conserve las instrucciones para uso futuro.

Revise este producto en busca de herraje dañado, juntas sueltas, pernos o fijaciones sueltos, piezas faltantes o bordes afilados antes y después del ensamblaje y frecuentemente durante el uso. Apriete firmemente los pernos y otras fijaciones que puedan estar sueltos.

NO use la cuna si hay alguna pieza faltante, dañada o rota.

Para pedir piezas de repuesto o manuales de instrucciones, póngase en contacto con Million Dollar Baby Co.

#### **PELIGRO DE ASFIXIA**

Nunca use bolsas plásticas de envío ni otros tipos de película plástica como cubiertas de colchones porque pueden causar asfixia.

Los bebés pueden asfixiarse en los huecos entre los costados de la cuna y un colchón que sea muy pequeño.

### **⚠️ ADVERTENCIA:**

Los bebés pueden asfixiarse sobre la ropa de cama blanda. Nunca agregue una almohada ni edredón. Nunca ponga acolchado adicional debajo de un bebé.

Para reducir el riesgo del síndrome de muerte infantil súbita (SMIS), los pediatras recomiendan poner a los bebés sanos boca arriba para dormir, a menos que su médico le indique otras instrucciones.

## **PRECAUCIÓN**

**CUALQUIER COLCHÓN UTILIZADO EN ESTA CUNA DEBE MEDIR POR LO MENOS 69 CM (27 1/4 PULGADAS) POR 131 CM (51 5/8 PULGADAS) Y TENER UN ESPESOR QUE NO SUPERE 15 CM (6 PULGADAS).**

### **⚠️ ADVERTENCIA:**

Utilice un colchón que no tenga más de 15 cm de grosor y sea de un tamaño tal que, al presionarlo firmemente contra cualquier lado de esta cuna, no deje un hueco de más de 3 cm entre el colchón y cualquier parte de cualquier otro lado de la cuna.

#### **PELIGRO DE ESTRANGULACIÓN**

¡Las cuerdas pueden causar estrangulación! No ponga objetos que tengan cuerdas alrededor del cuello de un niño, como cordones de capuchas ni de chupetes. No suspenda cuerdas encima de una cuna ni ponga cordeles en los juguetes.

Para ayudar a prevenir la estrangulación apriete bien todas las fijaciones. Pueden quedar atrapadas partes del cuerpo del niño o su ropa en las fijaciones sueltas.

NO ponga la cuna cerca de una ventana donde haya cordeles de persianas o cortinas que puedan estrangular a un niño.

#### **PELIGRO DE CAÍDA**

Cuando el niño pueda pararse solo, ponga el colchón en la posición más baja. Retire los protectores de la cuna, los juguetes grandes y otros objetos que pudieran servir como peldaños para salirse.

Deje de usar la cuna cuando el niño comience a subir para salirse o llegue a medir 89 cm (35 pulgadas) de estatura.

#### **DESPUÉS DEL ENSAMBLAJE**

NO sustituya piezas.

Si va a retocar el acabado, use un acabado no tóxico especificado para productos infantiles.

Siga las advertencias que tengan todos los productos en una cuna.



# ⚠️ AVERTISSEMENT

## ⚠️ AVERTISSEMENT:

La non-observation de ces avertissements et de ces instructions d'assemblage peut entraîner des blessures graves, voire mortelles.

### AVANT L'ASSEMBLAGE

Veillez lire toutes les instructions avant d'assembler le lit pour bébé. Conservez ces instructions pour une consultation ultérieure.

Avant l'assemblage de même qu'avant et après l'utilisation, assurez-vous de l'absence de quincaille endommagée, de joints desserrés, de boulons ou d'autres fixations desserrés, de pièces manquantes, de bords coupants. Serrez solidement les boulons et autres attaches desserrés.

N'utilisez PAS le lit pour bébé si une ou plusieurs pièces sont manquantes, endommagées ou brisées. Communiquez avec Million Dollar Baby Co. pour obtenir des pièces de rechange ou des manuels d'instructions.

### RISQUE D'ÉTOUFFEMENT

Pour éliminer les risques d'étouffement, n'utilisez jamais de sacs de plastique ou d'autres pellicules de plastique comme housses de matelas. Les bébés pourraient s'étouffer dans les espaces entre les côtés d'un lit de bébé et un matelas qui serait trop petit.

## ⚠️ AVERTISSEMENT:

Les bébés peuvent s'étouffer sur des objets de literie mous. N'ajoutez jamais d'oreiller ni de couettes. Ne placez jamais de capitonnage supplémentaire sous un nourrisson.

Pour réduire les risques de mort subite du nourrisson, les pédiatres recommandent de coucher les bébés en santé sur le dos, à moins d'avis contraire d'un pédiatre.

## MISE EN GARDE

TOUT MATELAS UTILISÉ DANS CE LIT POUR BÉBÉ DOIT ÊTRE D'AU MOINS 69 CM (27 1/4 PO) PAR 131 CM (51 5/8 PO) ET D'UNE ÉPAISSEUR NE DÉPASSANT PAS 15 CM (6 PO).

## ⚠️ MISE EN GARDE:

Utiliser un matelas dont l'épaisseur est d'au plus 15 cm et dont la superficie permet d'empêcher, lorsqu'il est poussé fermement contre un côté quelconque de ce lit d'enfant, qu'un espace de plus de 3 cm soit créé entre le matelas et une partie quelconque de tout autre côté.

### RISQUE D'ÉTOUFFEMENT

Les cordes présentent un risque d'étouffement. Ne placez pas des articles dotés d'une corde autour du cou d'un enfant, comme des capuchons avec des cordons ou des sucres avec des cordons. Ne suspendez pas de cordes au-dessus d'un lit de bébé et n'attachez pas de cordes aux jouets.

Pour prévenir l'étouffement, serrez toutes les attaches. Un enfant peut coincer des parties de son corps ou de ses vêtements dans des attaches desserrées.

Pour réduire les risques d'étouffement, NE placez PAS un lit de bébé près d'une fenêtre où des cordons pendent des stores ou des rideaux.

### RISQUE DE CHUTE

Lorsqu'un enfant est en mesure de se mettre en position debout, placez le matelas à la position la plus basse.

Retirez les tours de lits, les gros jouets et tout autre objet sur lequel l'enfant pourrait monter pour sortir du lit.

Cessez d'utiliser le lit pour bébé lorsque l'enfant commence à sortir du lit ou atteint une taille de 89 cm (35 po).

### APRÈS L'ASSEMBLAGE

NE substituez PAS des pièces.

En cas de remise en état, utilisez un fini non toxique convenant aux produits pour enfants. Respectez les avertissements de tous les produits dans un lit pour bébé.

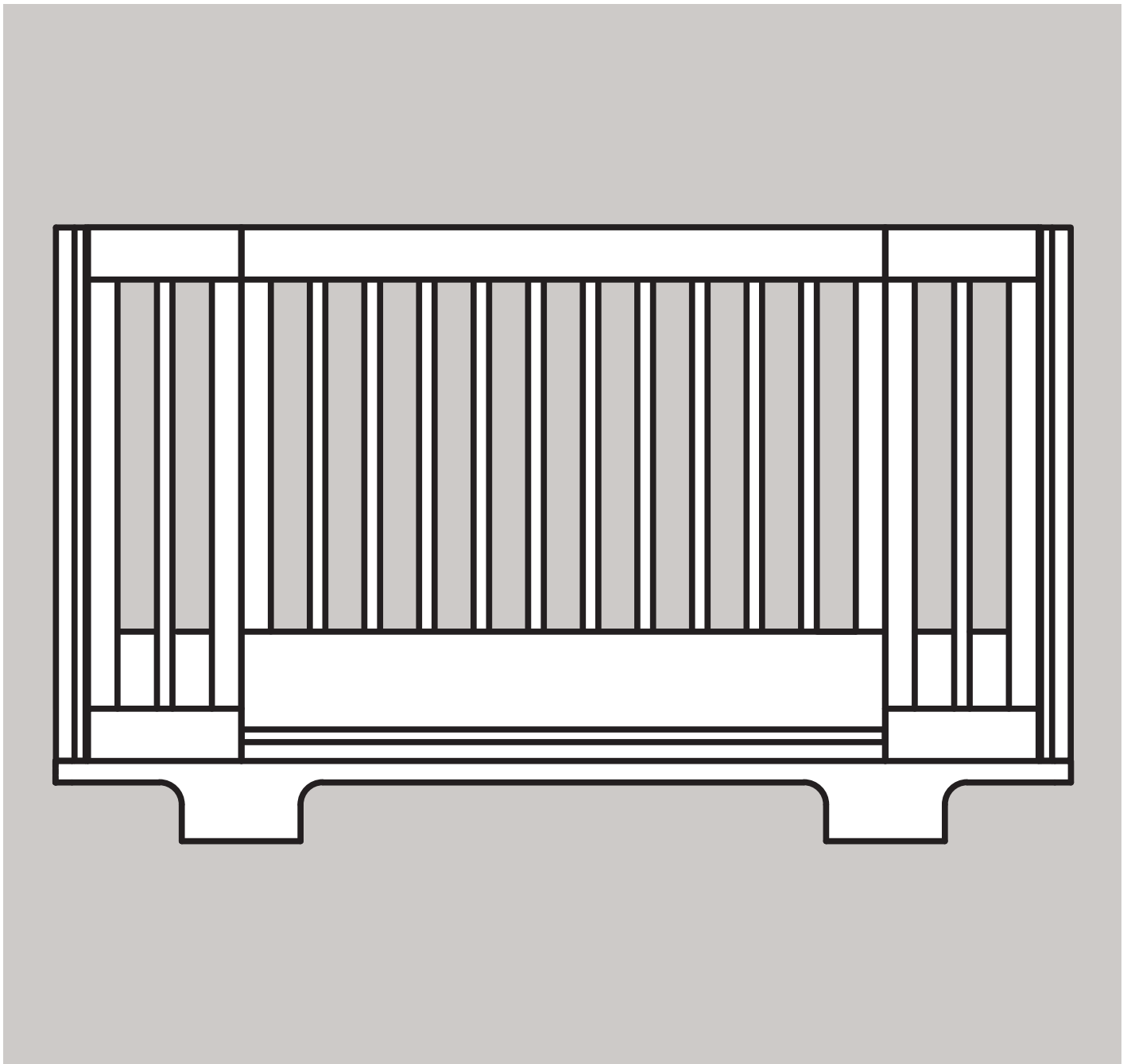

# Yuzu<sup>TM</sup> Toddler Bed

M23401

Toddler bed conversion  
Conversión para cama  
de bebé que ya camina  
Conversion en lit de bébé

assembly  
instructions

instrucciones  
de ensamblaje

instructions  
de montage

1

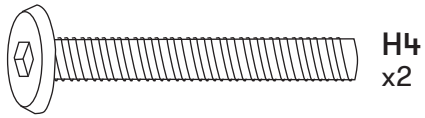

x2

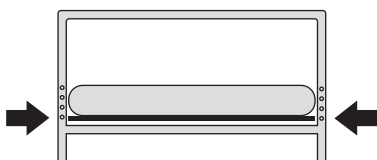
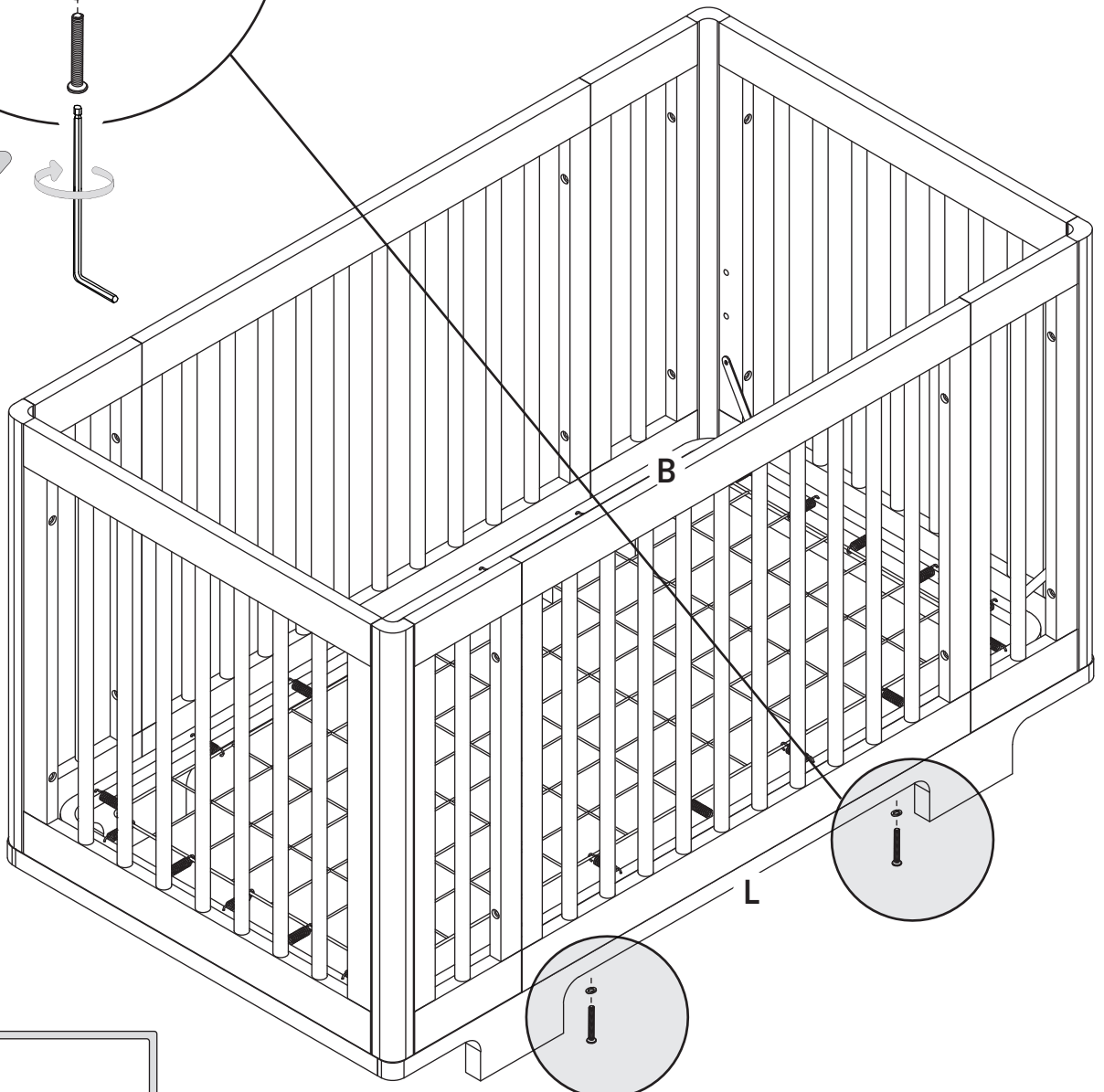
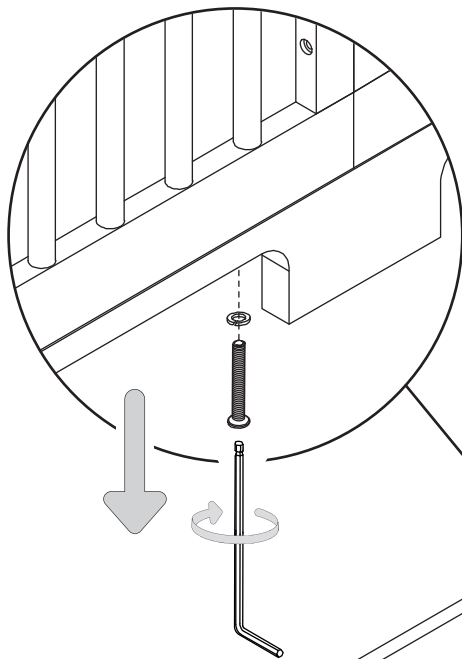

2

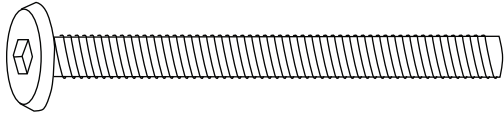

H2  
x4



H9  
x4

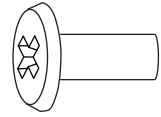

H11  
x4

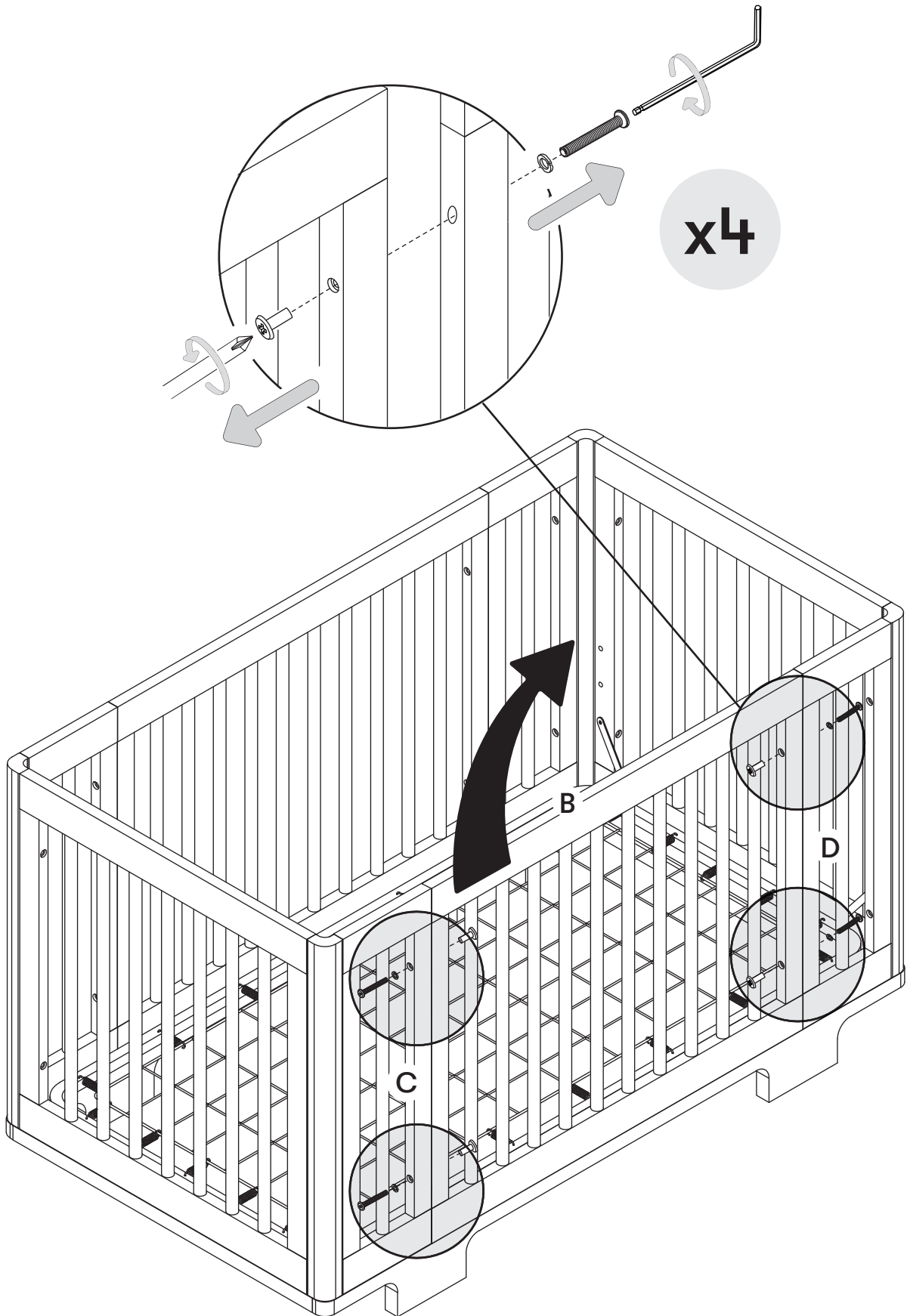

3

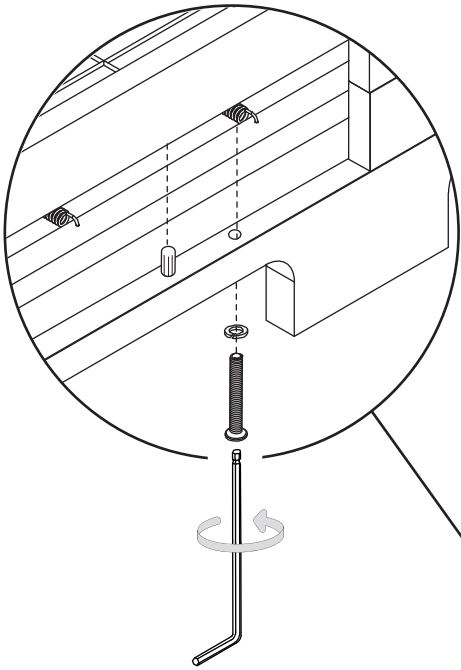
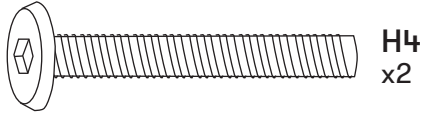

x2

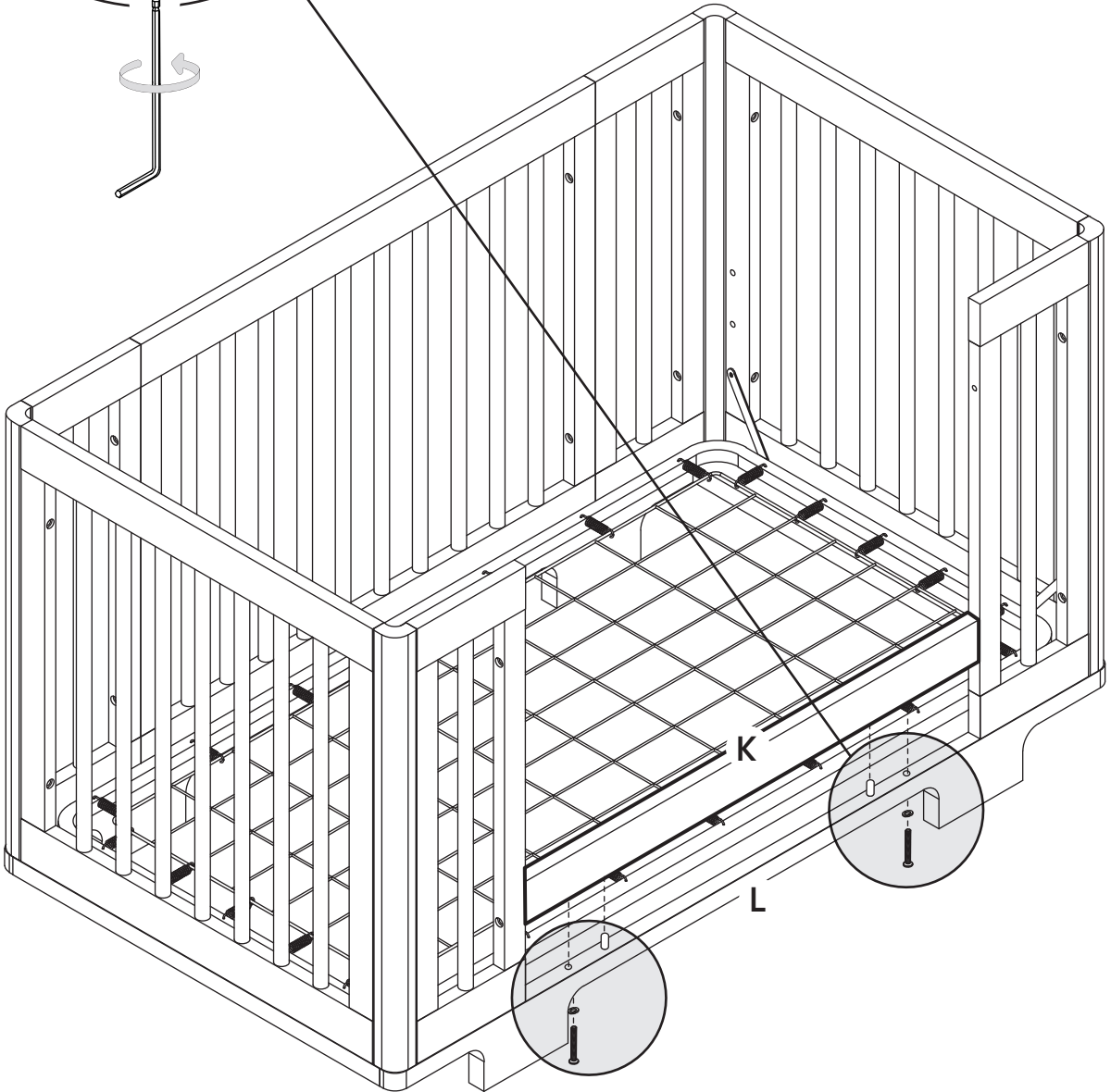
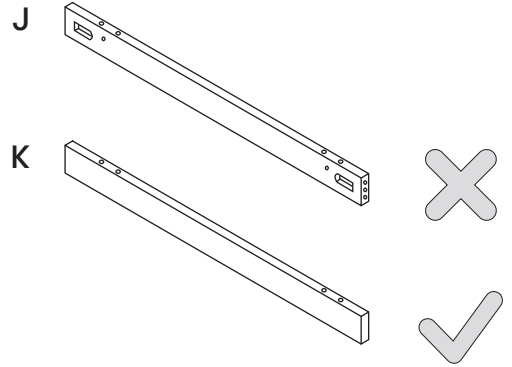

4

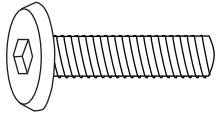

H6  
x4

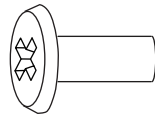

H11  
x4

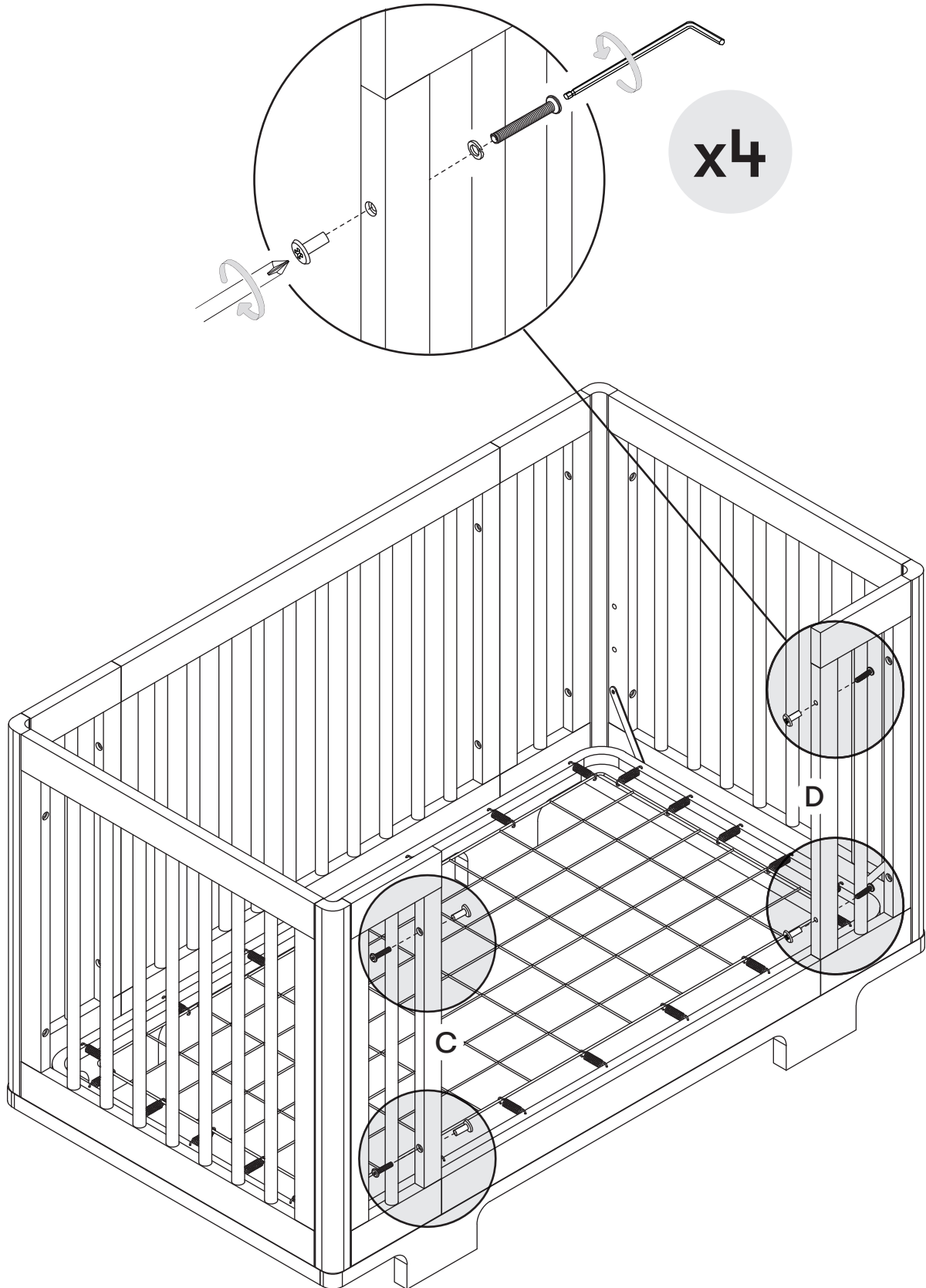

x4

*Voilà!*

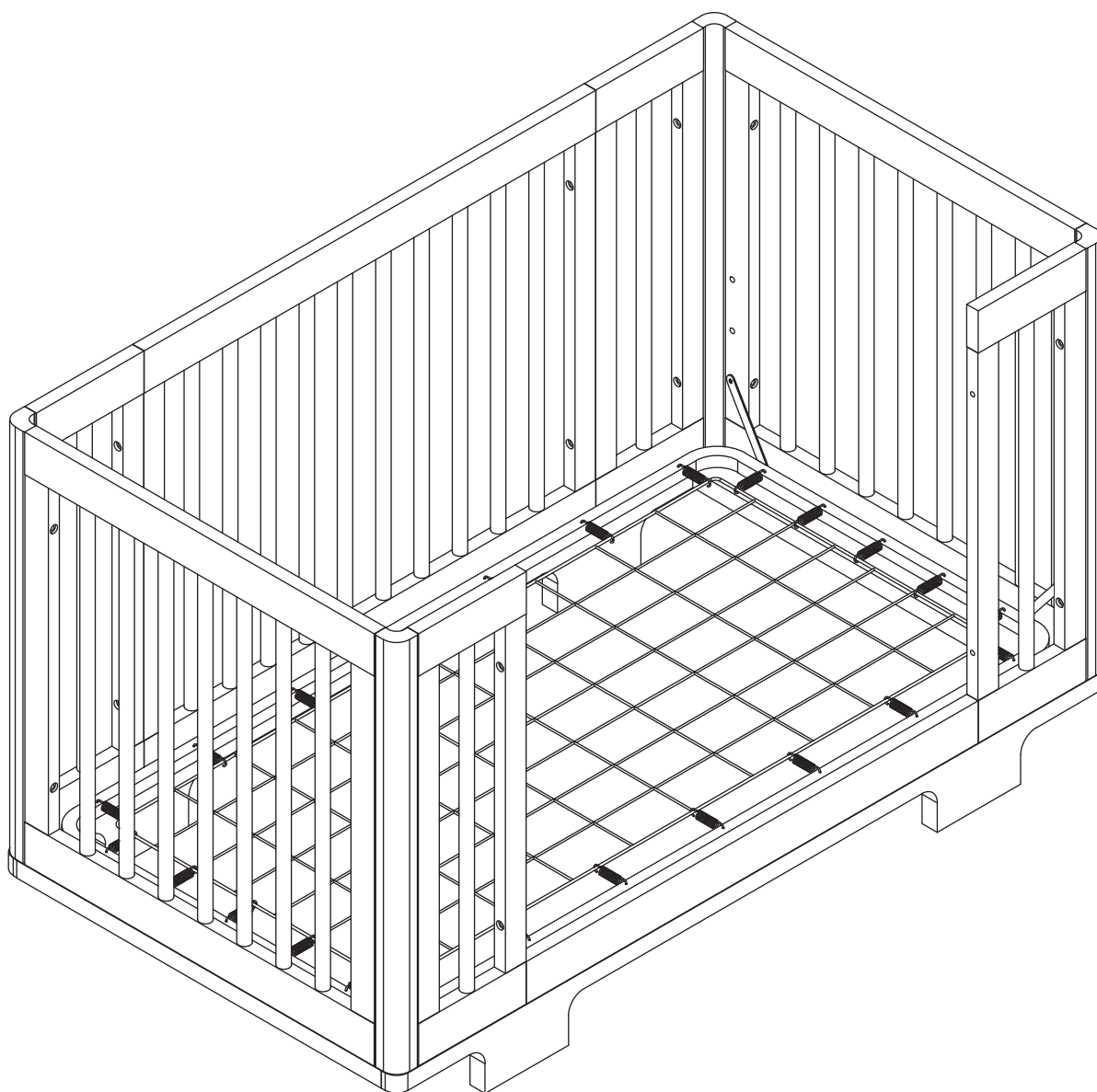

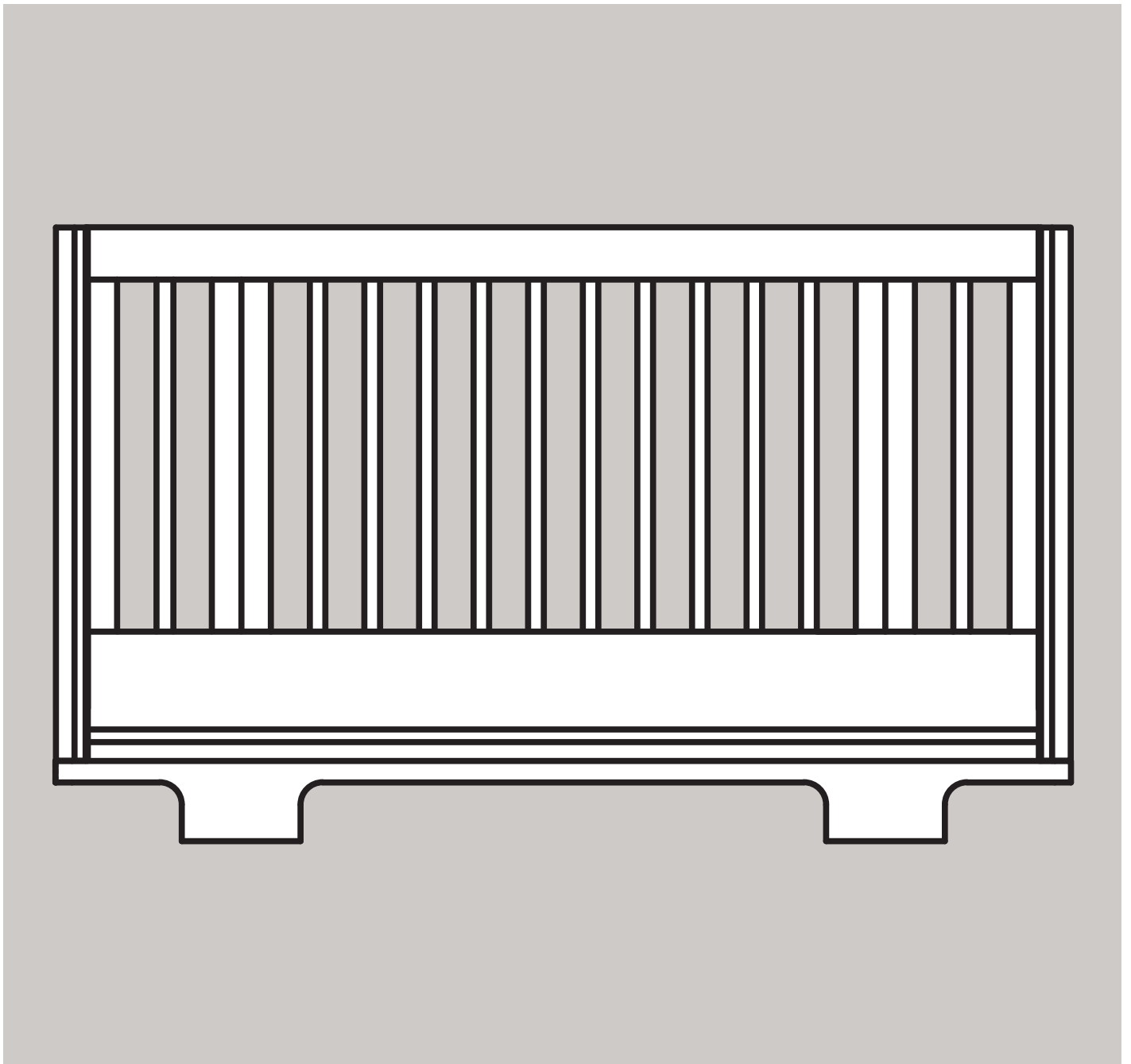

Yuzu<sup>TM</sup>  
Day Bed  
M23401

Day bed conversion  
Conversión para diván  
Conversion en lit de jour



assembly  
instructions

instrucciones  
de ensamblaje

instructions  
de montage

1

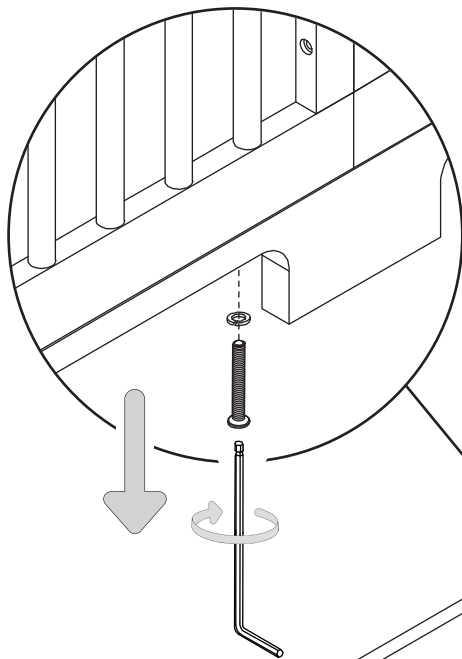
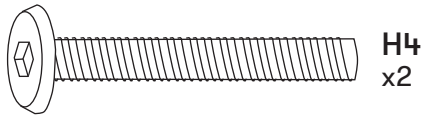

x2

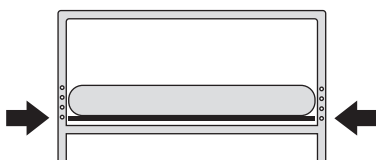
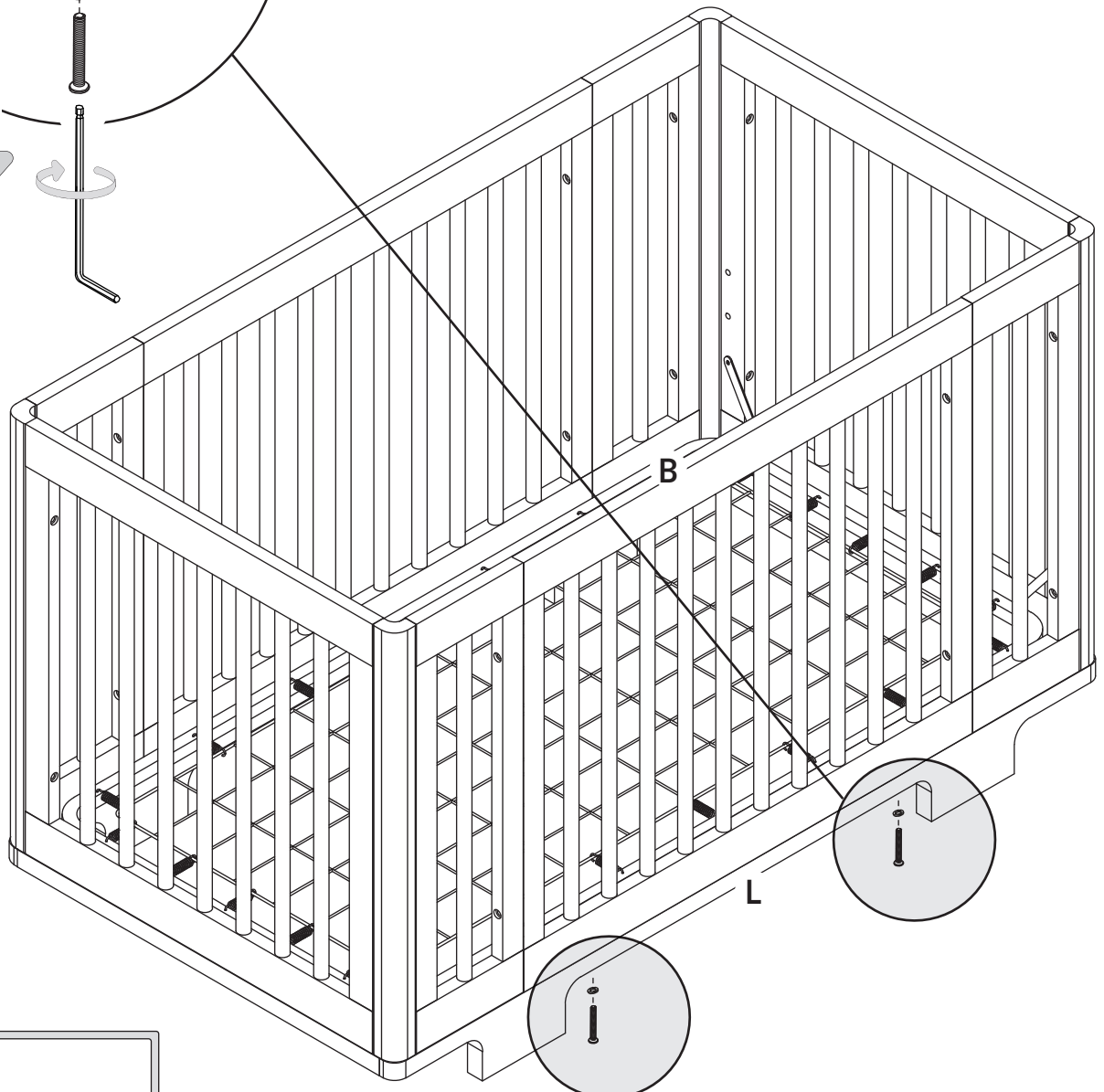

2

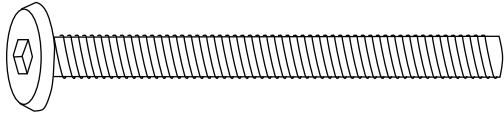

H2  
x4



H9  
x4

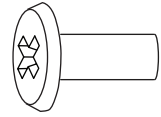

H11  
x4

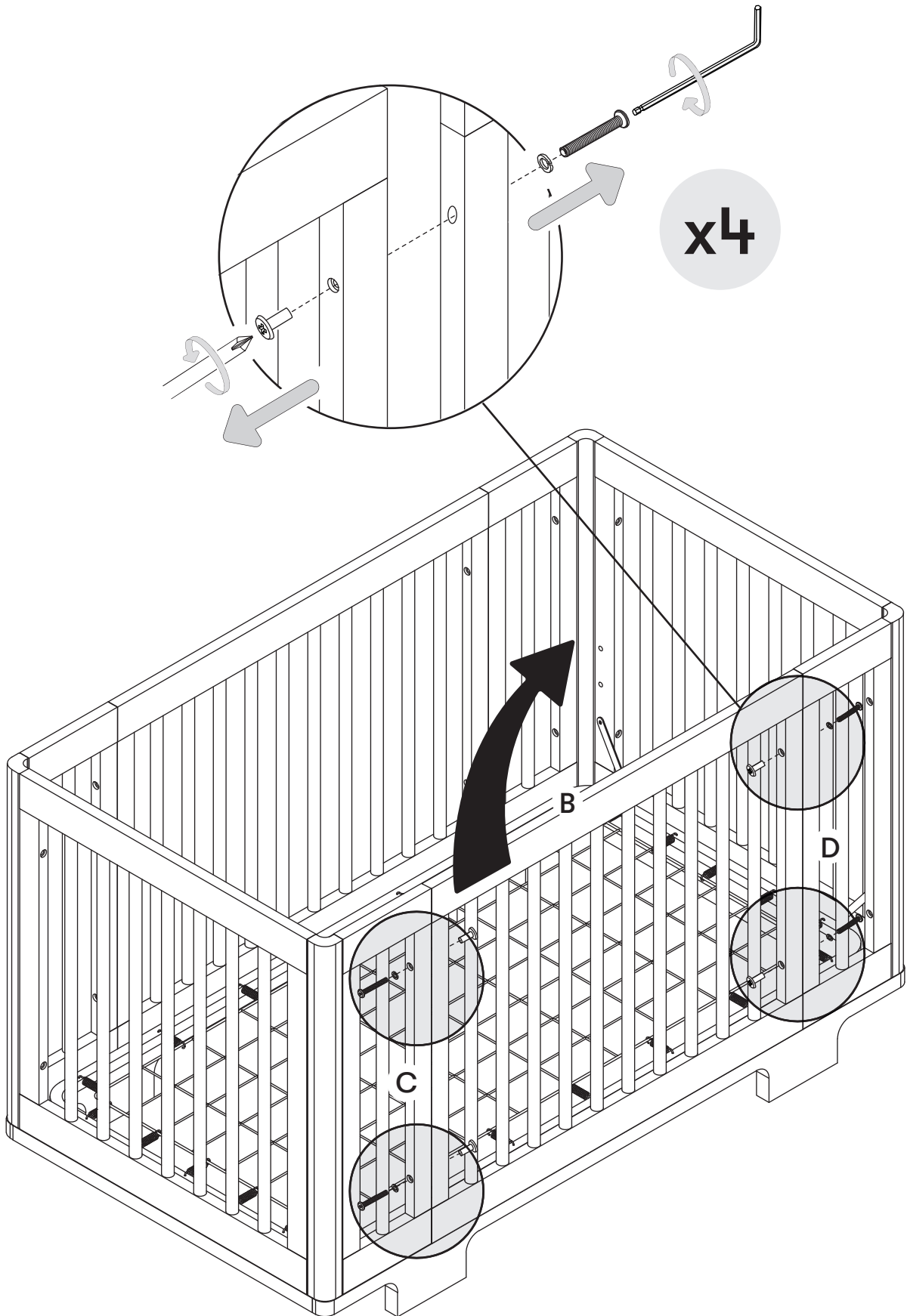

3

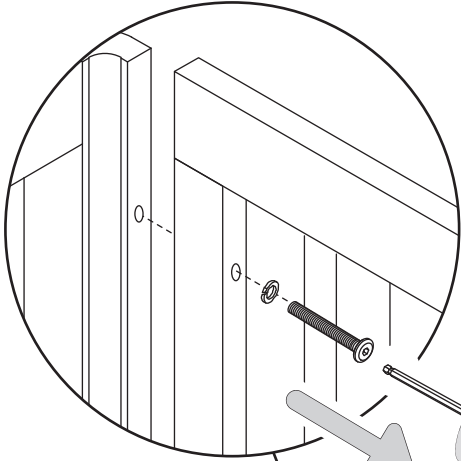
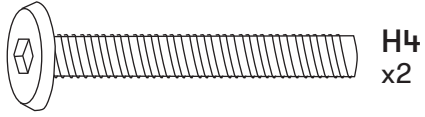

x4

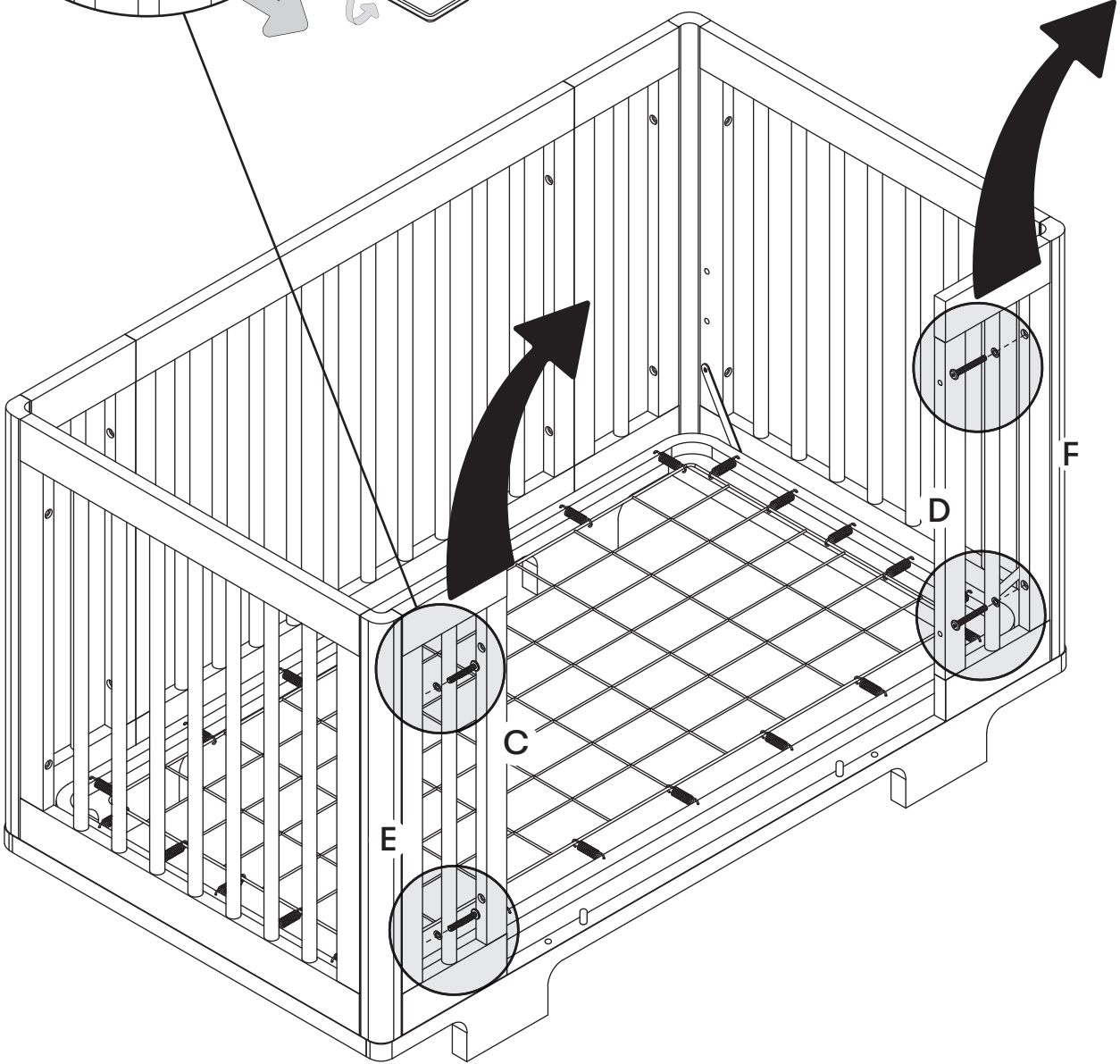

3

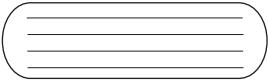

H10  
x4

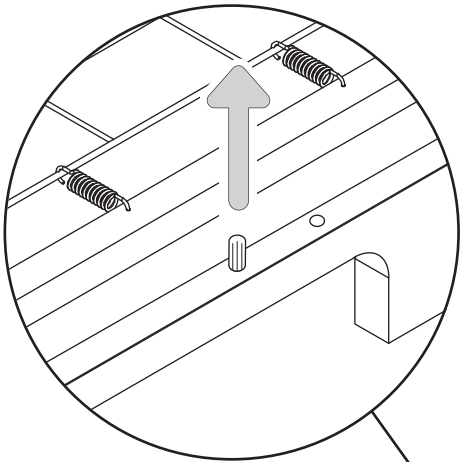

x4

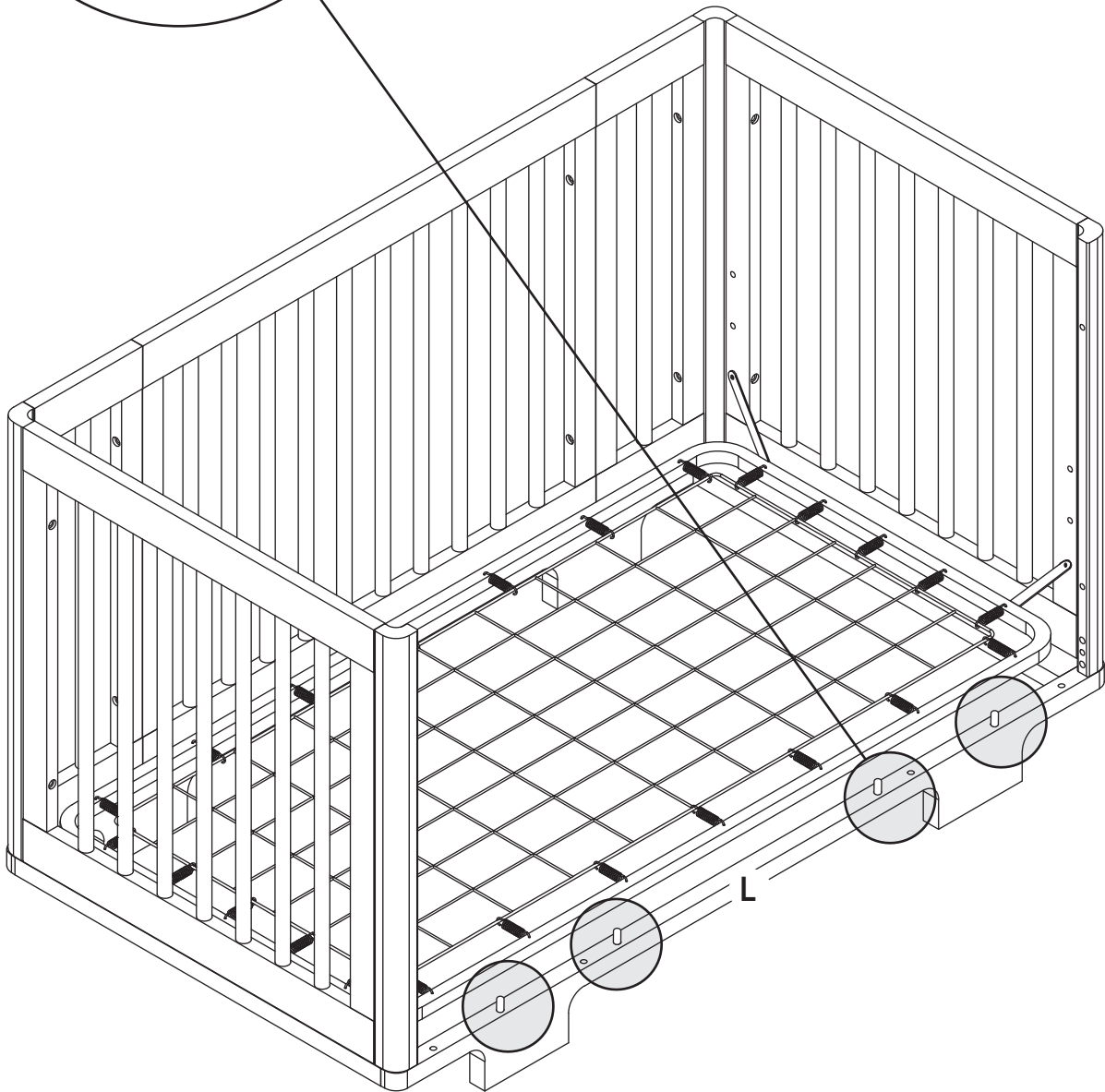

5

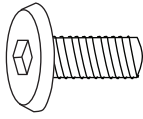

H7  
x4

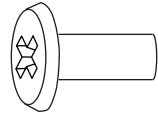

H11  
x4

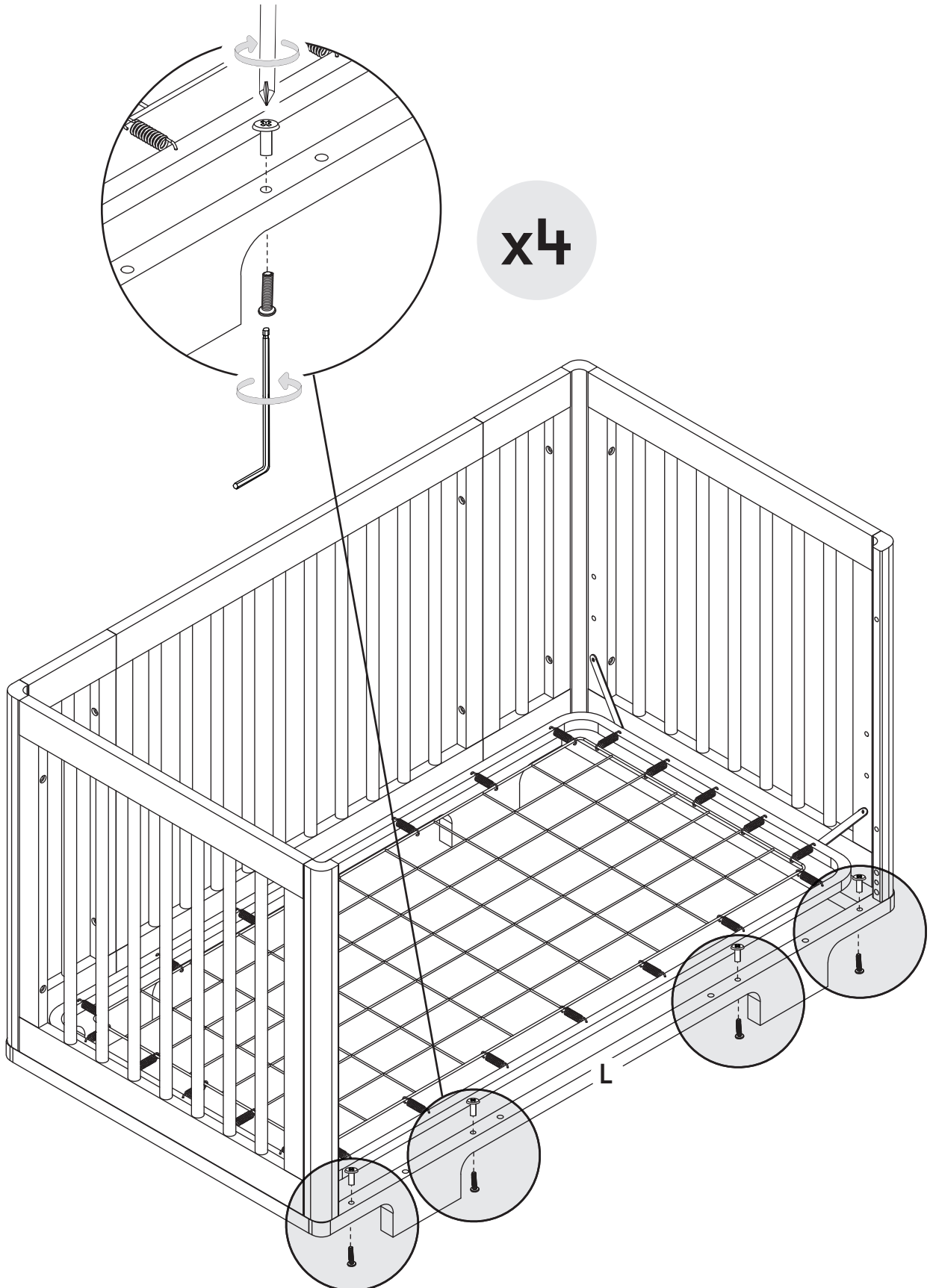

*Voilà!*

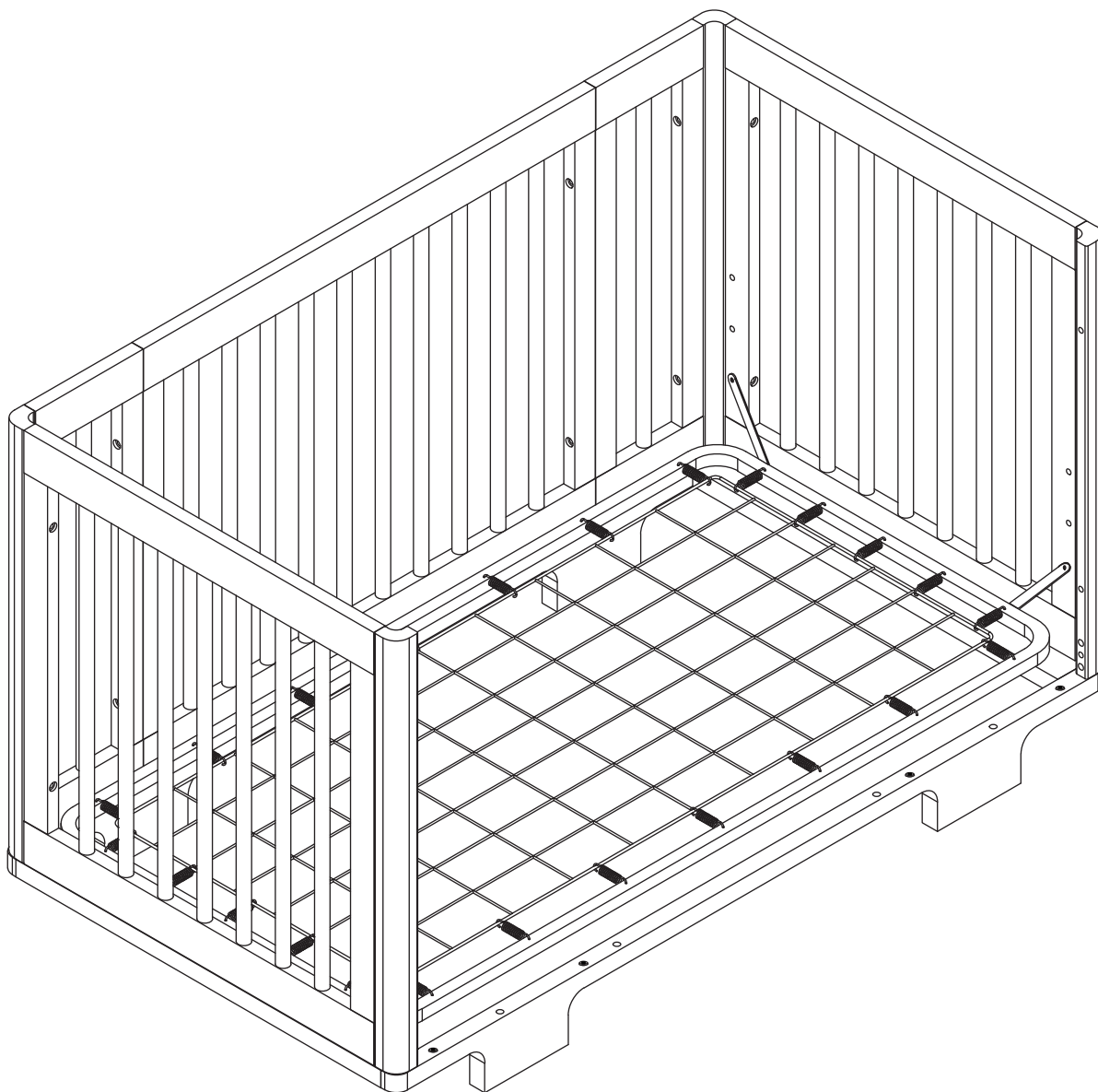

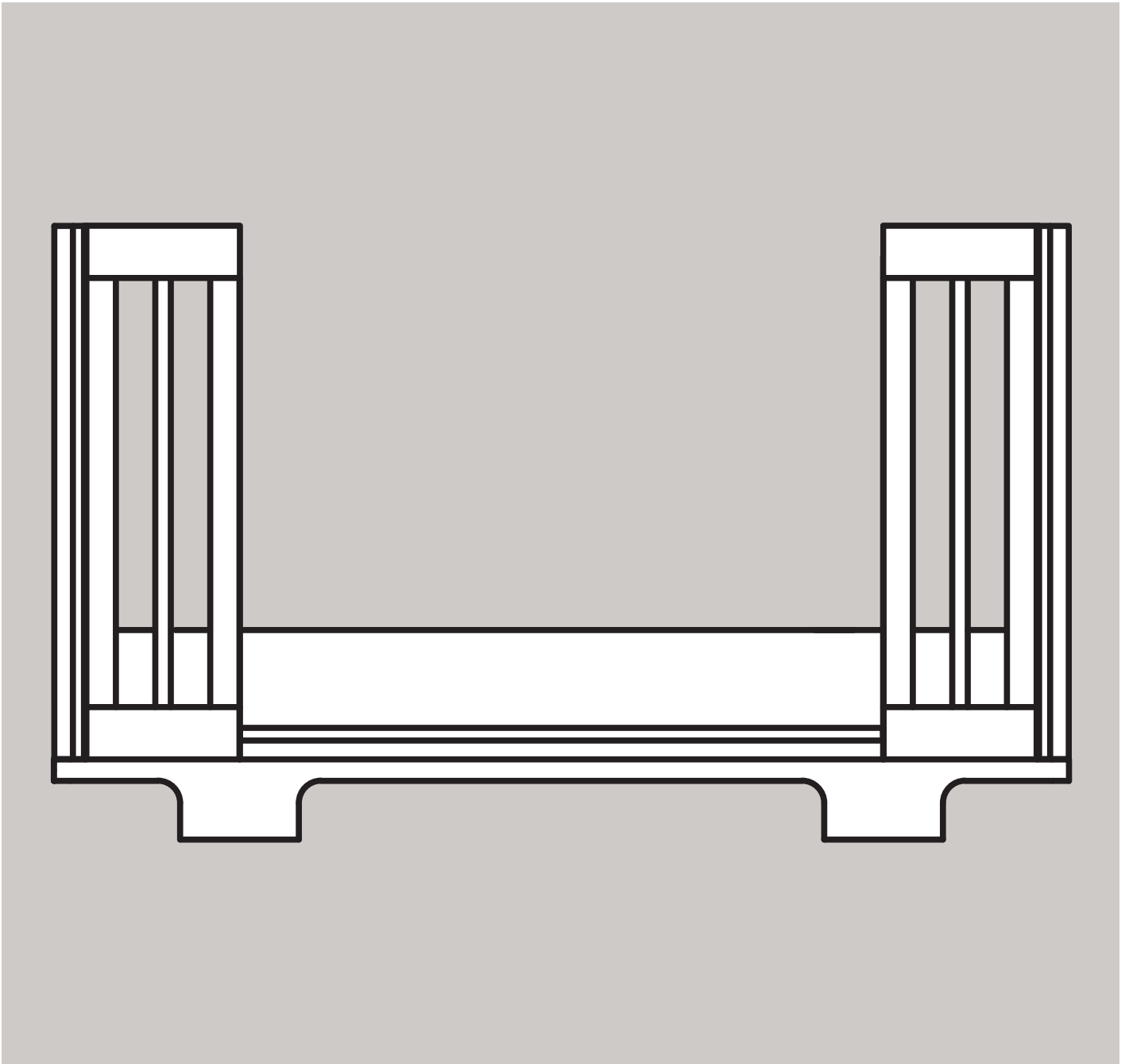

# Yuzu<sup>TM</sup> Junior Bed

M23401

Junior bed conversion  
Conversión para cama de junior  
Conversion en lit de junior

assembly  
instructions

instrucciones  
de ensamblaje

instructions  
de montage

1

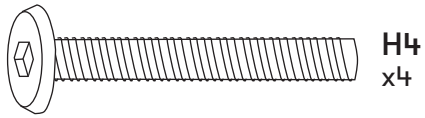

x4

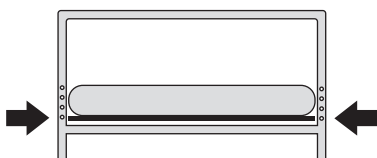
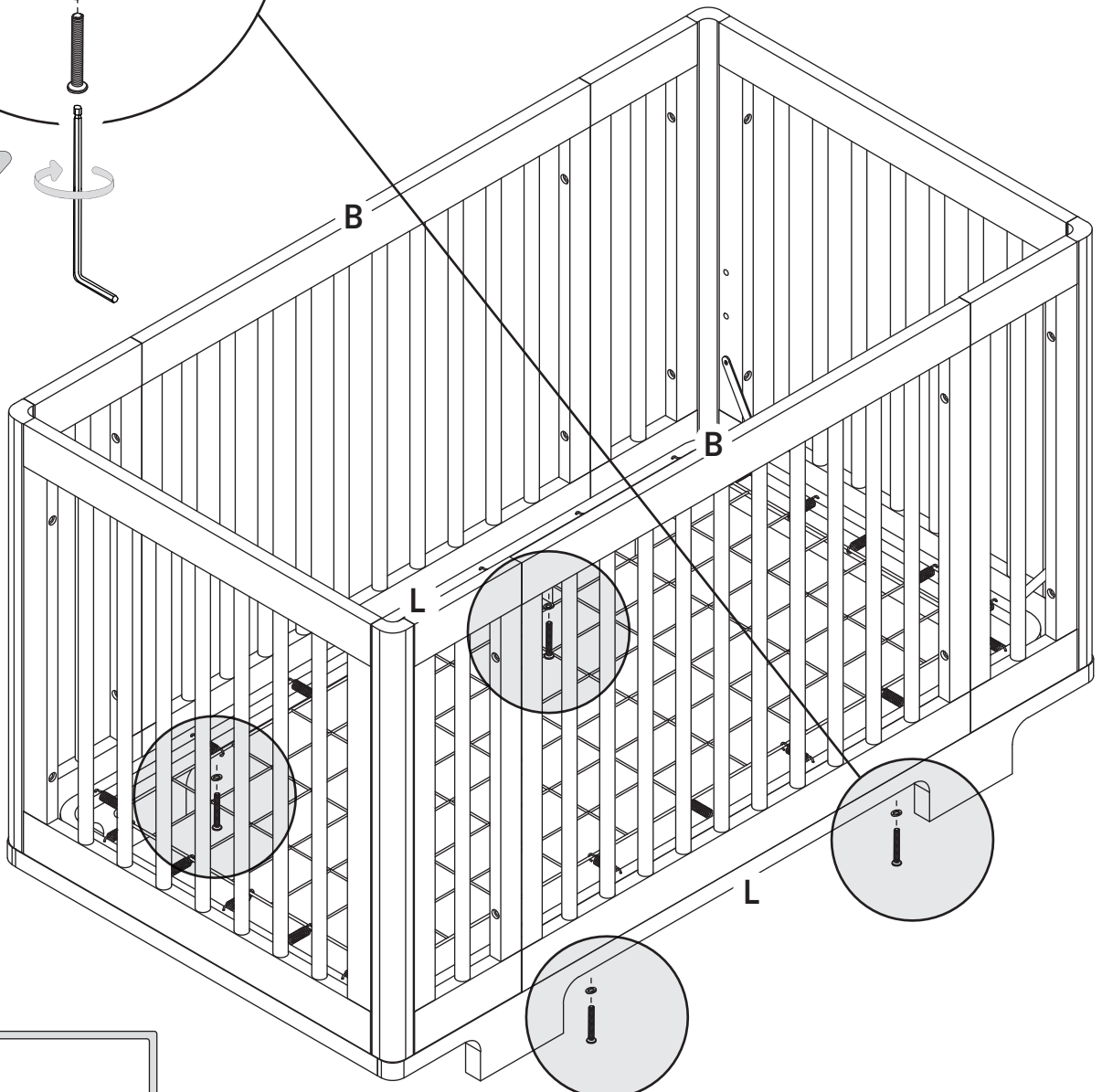
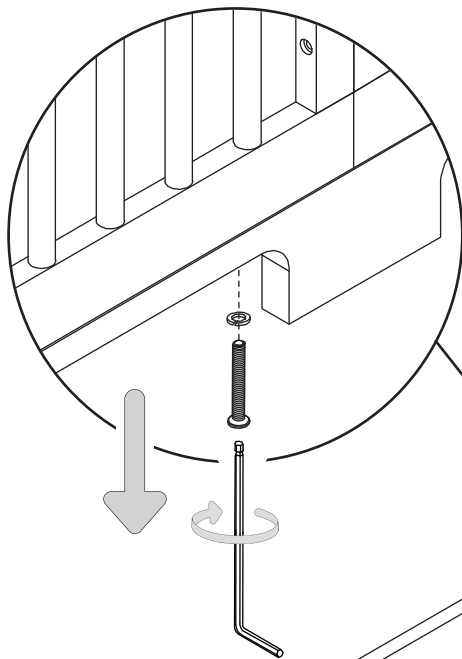



2

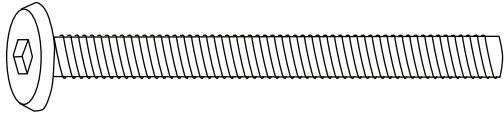

H2  
x8



H9  
x8

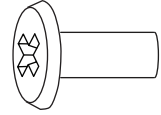

H11  
x8

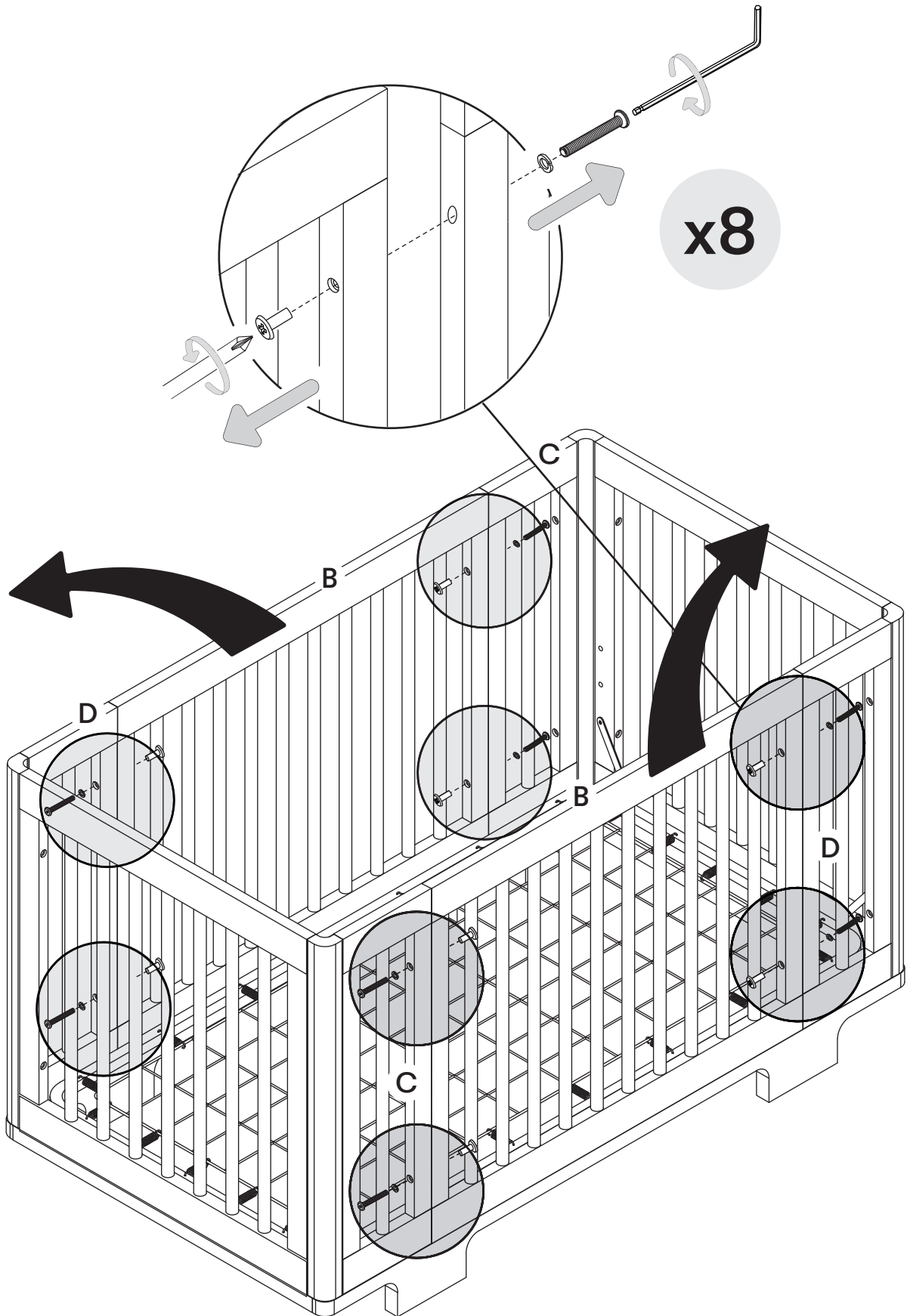

x8

3

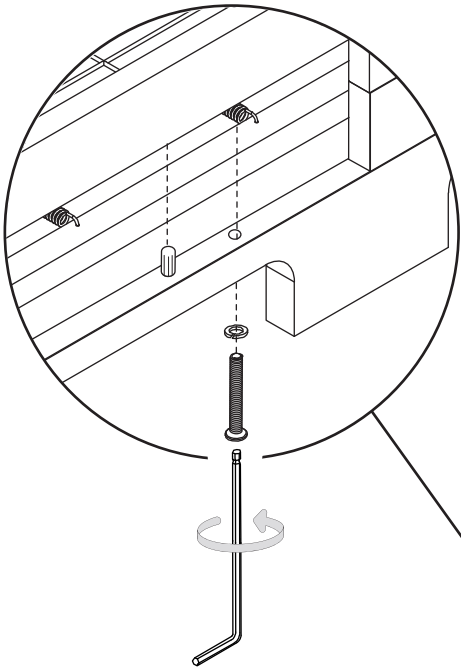

x4

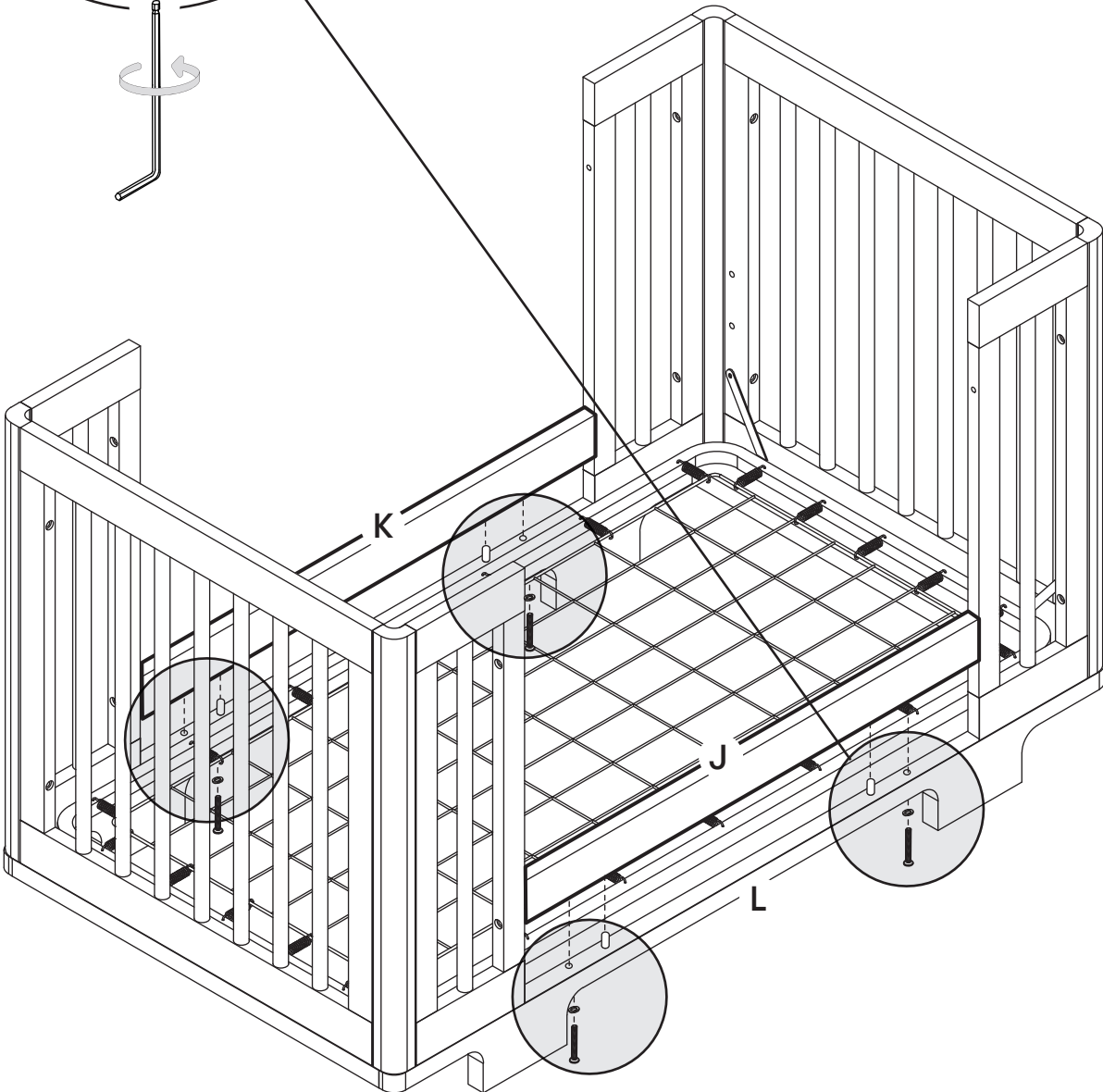

4

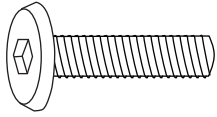

H6  
x8

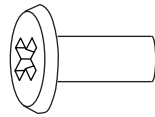

H11  
x8

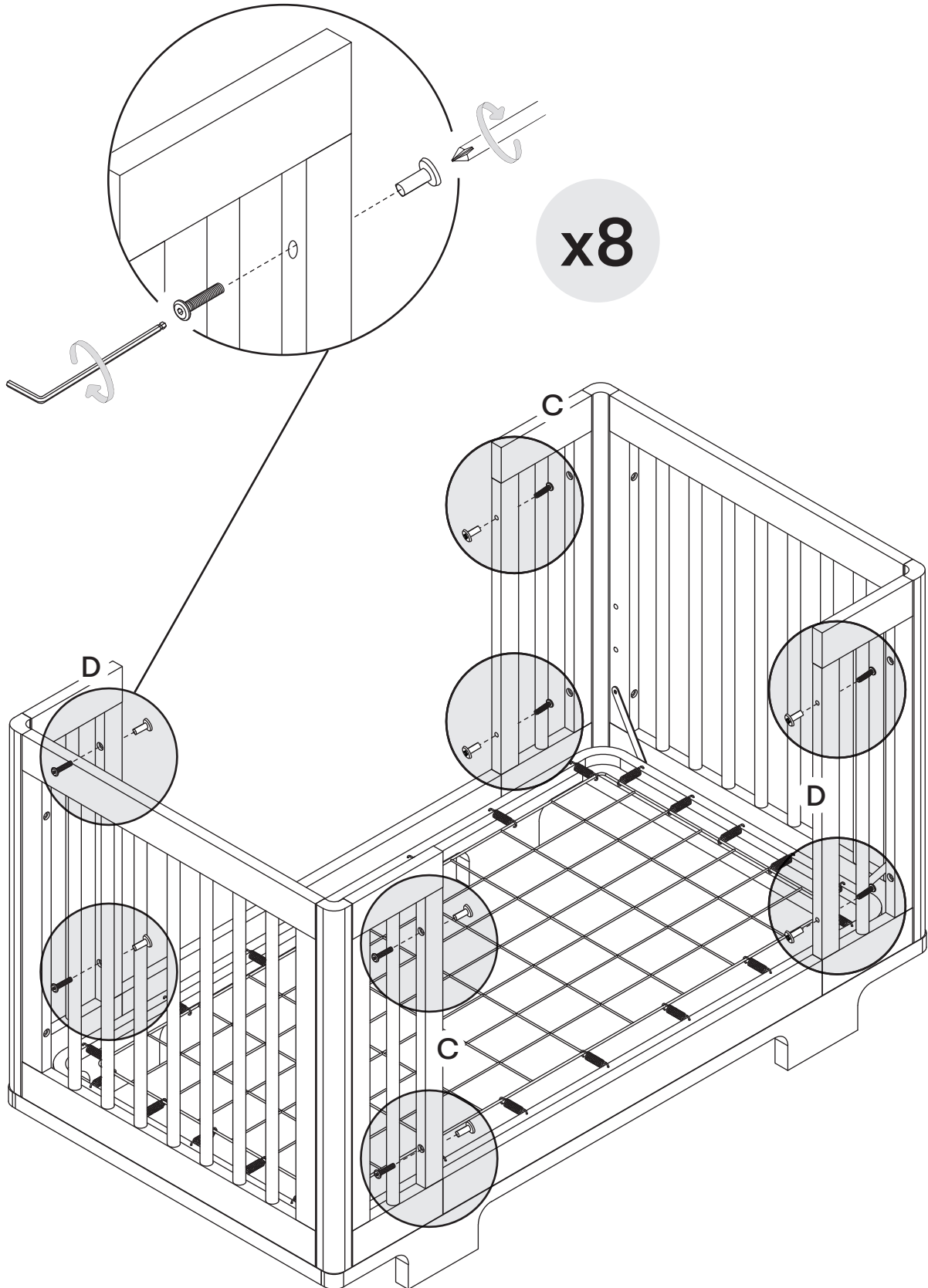

*Voilà!*

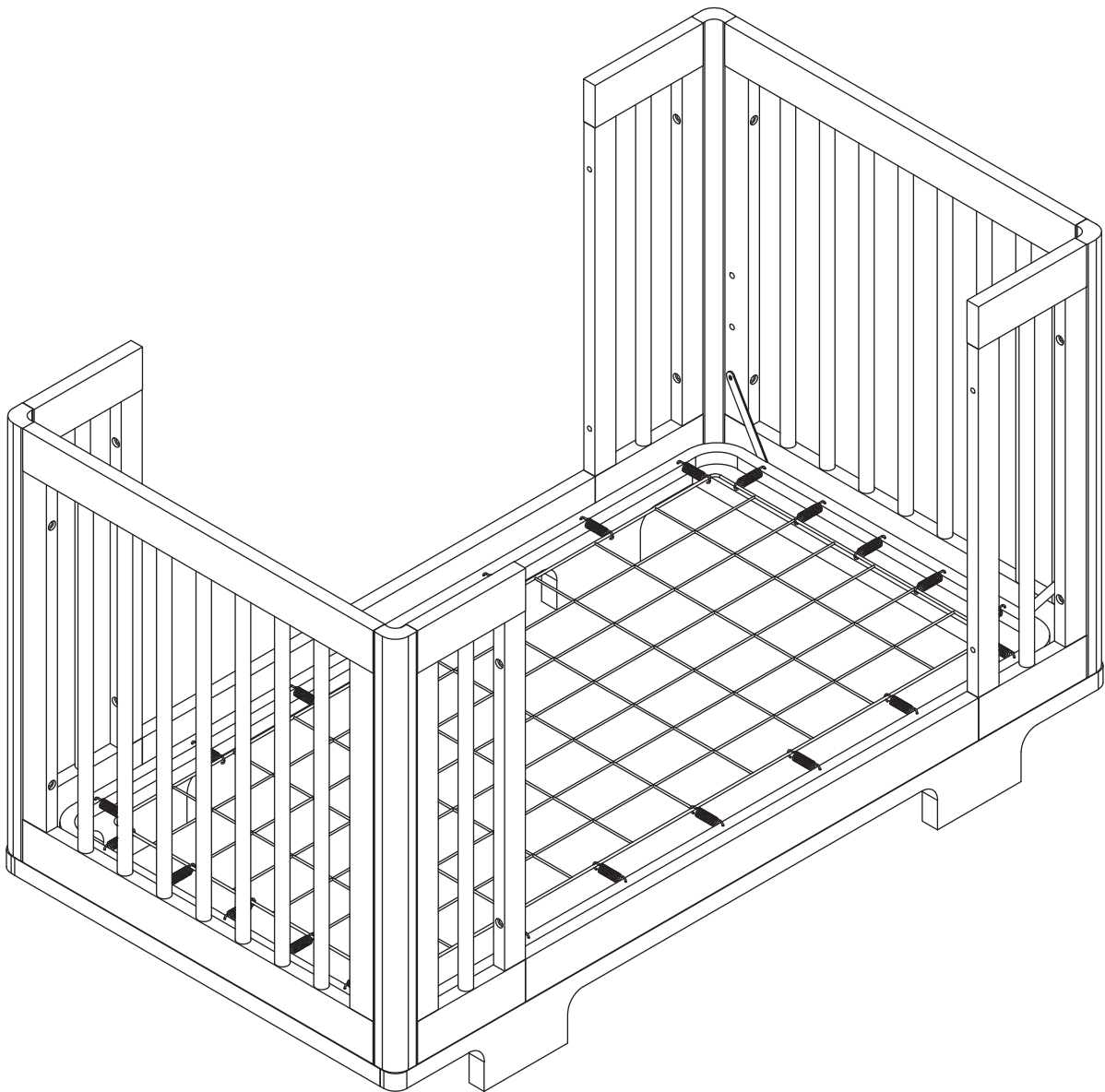

## **WARNING**

TO AVOID DANGEROUS GAPS, ANY MATTRESS USED IN THIS BED SHALL BE A FULL-SIZE CRIB MATTRESS AT LEAST 51 5/8 IN. (131 CM) IN LENGTH, 27 1/4 IN. (69 CM) IN WIDTH, AND A MAX THICKNESS OF 6 IN. (15 CM).

THE INTENDED USER'S MINIMUM AGE MUST BE AT LEAST 15 MONTHS OLD AND MAXIMUM WEIGHT MUST NOT EXCEED 50 LBS (22.7 KG).

---

## **ADVERTENCIA**

PARA EVITAR HUECOS PELIGROSOS, TODO COLCHÓN UTILIZADO EN ESTA CAMA DEBE SER UN COLCHÓN DE CUNA DE TAMAÑO COMPLETO QUE MIDA POR LO MENOS 131 CM (51 5/8 PULGADA) DE LARGO, 69 CM (27 1/4 PULGADA) DE ANCHO, Y QUE TENGA UN ESPESOR MÁXIMO DE 15 CM (6 PULGADA) .

LA EDAD MÍNIMA DEL USUARIO AL CUAL SE DESTINE DEBE SER DE 15 MESES Y SU PESO MÁXIMO NO DEBE SUPERAR 22.7 KG (50 LB).

---

## **AVERTISSEMENT**

POUR ÉVITER TOUT ÉCART DANGEREUX, LE MATELAS UTILISÉ DANS CE LIT DOIT ÊTRE UN MATELAS PLEINE TAILLE D'AU MOINS 131 CM (51 5/8 PO) DE LONGUEUR, 69 CM (27 1/4 PO) DE LARGUEUR ET D'UNE ÉPAISSEUR MAXIMALE DE 15 CM (6 PO).

L'ENFANT DOIT AVOIR AU MOINS 15 MOIS ET PESER AU MAXIMUM 22,7 KG (50 LB).



## storage

Because materials respond to temperature and humidity, it is important to store furniture in controlled environments. Furniture should not be placed in direct sunlight or near air-conditioning outlets, radiators, heaters, or humidifiers. Any changes such as extreme heat or cold, dampness, or dryness, may cause noticeable shrinkage or swelling of wood. Direct sunlight may affect the coloring of materials over time.



## care and cleaning

To clean wood or metal parts, use a lint-free, soft cloth with a non-toxic cleaner. Wipe dry immediately. To avoid scratches or other damages, do not use abrasive chemicals or materials. For fabrics, we recommend using a non-toxic foaming fabric cleaner or leather cleaner where appropriate. Touch up kits are available for purchase by contacting us at:

(323) 282-5163 or [INFO@MDBMAIL.COM](mailto:INFO@MDBMAIL.COM)



## registration

Registering your product is simple. You can do so at:

[BABYLETTO.COM/REGISTRATIONS](http://BABYLETTO.COM/REGISTRATIONS)



## part replacement

If you would like to order replacement or missing parts, please visit us at:

[BABYLETTO.COM/PARTS](http://BABYLETTO.COM/PARTS)

or you can contact us by mail at:

8700 REX RD. PICO RIVERA, CA 90660



## one year limited warranty

Oops! Did we make a mistake? No worries, your Babyletto product is covered under warranty for one year after the date of purchase. For more details on our warranty policy, please visit:

[BABYLETTO.COM/WARRANTY](http://BABYLETTO.COM/WARRANTY)



## almacenamiento

Dado que los materiales responden a la temperatura y la humedad, es importante guardar muebles en ambientes controlados. No deben ponerse los muebles a la luz solar directa ni cerca de salidas de aire acondicionado, radiadores, calefactores ni humidificadores. Cualquier cambio como los extremos de calor o frío, humedad o sequedad, pueden causar notoriamente encogimiento o hinchazón en la madera. La luz solar directa puede afectar la coloración de los materiales con el paso del tiempo.



## cuidado y limpieza

Para limpiar piezas de madera o metal, use un paño suave sin pelusa con un limpiador no tóxico. Seque con un paño inmediatamente. Para evitar rayar o dañar la superficie, no use agentes químicos ni materiales abrasivos. En cuanto a las telas, recomendamos usar una espuma limpiadora no tóxica para telas o un limpiador para cuero según corresponda. Hay kits para retocar disponibles para la venta contactándonos en:  
(323) 282-5163 o [INFO@MDBMAIL.COM](mailto:INFO@MDBMAIL.COM)



## registrarse

Es sencillo registrar su producto. Puede hacerlo en:

[BABYLETTO.COM/REGISTRATIONS](http://BABYLETTO.COM/REGISTRATIONS)



## recambio de piezas

Si quisiera pedir repuestos o piezas faltantes, visítenos en:

[BABYLETTO.COM/PARTS](http://BABYLETTO.COM/PARTS)

o puede contactarnos por correo en:

8700 REX RD. PICO RIVERA, CA 90660



## garantía limitada de un año

¡Ups! ¿Cometimos un error? No se preocupe, este producto Babyletto está cubierto por una garantía de un año a partir de la fecha de compra. Para conocer más detalles sobre nuestra política de garantía, visite:

[BABYLETTO.COM/WARRANTY](http://BABYLETTO.COM/WARRANTY)



## rangement

Compte tenu que les matériaux réagissent à la température et à l'humidité, il importe de ranger le mobilier dans des environnements contrôlés. Le mobilier ne doit pas être placé en plein soleil ni près des sorties d'air climatisé, des radiateurs, des appareils de chauffage ou des humidificateurs. Tout changement comme un froid ou une chaleur extrême, de l'humidité ou de la sécheresse pourrait causer la contraction ou le gonflement du bois. La lumière directe du soleil peut altérer la couleur des matériaux au fil du temps.



## nettoyage et entretien

Pour nettoyer le bois ou les pièces métalliques, utilisez un chiffon doux sans peluche et un produit nettoyant non toxique. Essayez immédiatement. Pour éviter les égratignures ou autres dommages, veillez à ne pas utiliser des produits chimiques ou des matériaux abrasifs. Pour les tissus, il est recommandé d'utiliser un produit nettoyant pour tissus non toxique ou pour cuir le cas échéant. Il est possible de se procurer des nécessaires de retouches en nous contactant à :

(323) 282-5163 ou [INFO@MDBMAIL.COM](mailto:INFO@MDBMAIL.COM)



## enregistrement

L'enregistrement du produit est simple à réaliser. Il suffit d'aller sur la page :

[BABYLETTO.COM/REGISTRATIONS](http://BABYLETTO.COM/REGISTRATIONS)



## pièces de rechange

Pour commander des pièces de rechange ou manquantes, veuillez visiter :

[BABYLETTO.COM/PARTS](http://BABYLETTO.COM/PARTS)

ou communiquer avec nous par courriel à l'adresse :

8700 REX RD. PICO RIVERA, CA 90660



## garantie limitée d'un an

Oups! Avons-nous fait un erreur? Ne vous inquiétez pas. Votre produit Babyletto est couvert par une garantie d'un an à compter de la date d'achat. Pour plus de détails sur la politique de garantie, veuillez visiter :

[BABYLETTO.COM/WARRANTY](http://BABYLETTO.COM/WARRANTY)



