



PERFORMANCE

TRANSMISSION CONTROLS & ACCESSORIES





America's Number One Shifter

Known as "America's Number 1 Shifter Company", Hurst proudly maintains a wide variety of quality products for the performance enthusiast. Over the years, Hurst has been the OEM shifter supplier for the Pontiac GTO, Plymouth Barracuda, Plymouth Super Bird, Ford Mustang Boss 302, Oldsmobile, AMC and now the new Dodge SRT-10 Pick-Up, just to name a few.

When you purchase a Hurst Shifter or accessory, you are receiving a piece of legendary Hurst heritage and quality. From Drag Racing to Street Rods, Circle Track to Street Machines, Hurst manufactures quality-engineered shifters, accessories and transmission products to fit the needs of the performance minded driver.



CONTENTS



AUTOMATIC SHIFTERS

	PAGES
Accessories	11
Auto/Stick 3	8
Dual Gate	9
Pistol Grip Quarter Stick	5
Pistol Grip Quarter Stick 2	6
ProMatic 2	2
Quarter Stick	4
Quarter Stick 2	6
Street Rod	10
V-Matic 2	3

MANUAL SHIFTERS

	12 - 22
Billet/Plus 5&6 Speed	12-18
Competition Plus - 4 & 5 Speed	13-18
Mastershift 3 Speed	20-21
Pick-up Trucks & Jeeps	18
Quick/Stick - Sport Compacts	22
Street Super/Shifter 4 Speed	19

INDY SHIFTERS

	23 - 25
Automatic	24
Qualifier 3 Speed	25
SSA 3 Speed	25
Truck 3 Speed	24
Universal 4 Speed	23

RACING and SPECIALTY SHIFTERS

	26 - 31
Lightening Rods for Lenco's	30
Pro V-Gate 5	29
Richmond 5 Speed	28
Speedway Super/Shifter	31
Super/Shifter 3	27
V-Gate 2 In-Line Shifter	26

SHIFTER/TRANS ACCESSORIES

	32 - 39
Hot Shift ATF Fluid	39
Hot Shift Kits	38
Roll/Control, Line/Loc	32
Roll/Control Accessories	32-33
Shifter Boots	37
Shifter Knobs	33-35
T-Handles	33, 35, 36
Transmission Swap Kits	39

SERVICE PARTS

	40 - 55
Components	40-50
Manual Shifter Assembly Drawings	50
Shifter Sticks, Bolt-on	47-49
Trans ID Charts	51-55

PROMOTIONAL ITEMS

56-59

NUMERICAL INDEX

60-64

WARRANTY & REBUILD INFORMATION

IBC





AUTOMATIC SHIFTERS

PRO-MATIC 2™ RATCHET SHIFTER

The Hurst Pro-Matic 2 Ratchet Action Shifter is quality engineered for years of precise, trouble-free operation. The Pro-Matic 2 gives a custom appearance to any vehicle and is ideal for street or strip performance.

The Pro-Matic 2 for trucks incorporates an extended shifter stick for ease of operation and is designed to fit most pick-up trucks.



#383 8500

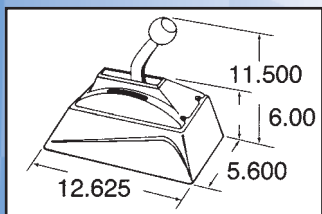

#383 8500



#383 8510

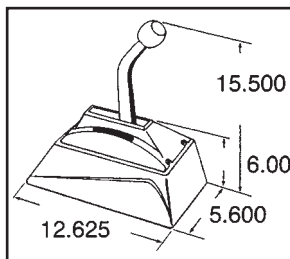

#383 8510



- Full forward and reverse ratchet action can be used with either standard or reverse pattern valve bodies

OPERATION OF SHIFTER FROM PARK:

From the park position, lift up on handle and pull back into reverse. From reverse pull back into neutral, push down and ratchet into gear.

OPERATION OF SHIFTER FROM DRIVE GEAR:

Ratchet into neutral. Pull up on handle and push into reverse. From reverse, pull up on handle and push into park.

- Cable-operated to provide your choice of mounting locations
- Progressively illuminated gear position indicator
- Incorporates a neutral safety and back-up light switch assembly
- Attractive black textured console with chrome-plated top cover can be trimmed to fit any floor contour
- Chrome-plated stick and a black knob (3/8-16 thread) give the shifter a custom look
- Complete with hardware, heavy-duty 5' long shifter cable, and easy to follow installation guide
- Positive reverse Loc/Out for NHRA and IHRA requirements

APPLICATIONS

Make	Transmission	Trans. Code	CAR	TRUCK
			Part No.	Part No.
GM	TH 250, 350, 375, 400	242, 243	383 8500	383 8510
GM	TH 700 R4 and 200 4R	246, 247	383 8504	383 8511
GM	62-73 Powerglide (Aluminum Case)	245	383 8505	—
Ford	C-4 and C-6	231, 232	383 8500	383 8510
Mopar	Torqueflite A727-A904	221, 222	383 8500	383 8510
AMC	Torque Command A727-A904	221, 222	383 8500	383 8510

See page 41 for service parts.
See page 51 for trans code information.

AUTOMATIC SHIFTERS



V-MATIC 2™ DUAL MODE SHIFTER

The V-Matic 2 features a dual mode operation for street performance or all out racing.

IN-LINE GATE MODE:

From the park position, pull up on the reverse Loc/Out handle. Pull back into reverse, push down and simply pull back into neutral or desired gear.

RATCHET MODE:

From the park position, pull up on the reverse Loc/Out handle and move into reverse. Push down and pull back to neutral. Push down in neutral and ratchet into gear.

- Highly polished shifter lever and brushed aluminum Hurst T-handle (3/8-16 thread).
- Trigger operated reverse Loc/Out for NHRA and IHRA requirements.
- Incorporates a neutral safety and back-up light switch assembly.
- Progressively illuminated gear position indicator.
- Attractive black textured console with chrome-plated top cover can be trimmed to fit any floor contour.
- Complete with all hardware, heavy-duty 5' long shifter cable, and easy to follow installation guide.

#383 8520

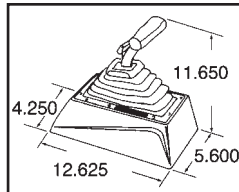

APPLICATIONS

V-MATIC 2

Make	Transmission	Trans. Code	Part No.
GM	TH 250,350, 400	242, 243	383 8520
GM	TH 700 R4 and 200 4R	246, 247	383 8521
GM	62-73 Powerglide (Aluminum case)	245	383 8525
Ford	C-4 and C-6	231, 232	383 8520
Mopar	Torqueflite A727 and A904	221, 222	383 8520
AMC	Torqueflite A727 and A904	221, 222	383 8520

V-MATIC 2 CONSOLE MODEL

Make	Transmission	Trans. Code	Part No.
Camaro	73-81 TH 250, 350, 375, 400	242, 243	383 8515+
Firebird	70-81 TH 250, 350, 375, 400	242, 243	383 8515+

See page 41 for service parts.

+ Utilizes factory GM cable, factory back-up light and neutral safety switch.
See page 51 for trans code information.



AUTOMATIC SHIFTERS

THE ORIGINAL QUARTER STICK®

The award-winning Quarter Stick Automatic Shifter is designed to provide positive gear change control for street or racing transmission applications.

- Designed for 2, 3 and 4-speed automatic transmissions in both forward and reverse valve body shift patterns
- Detent activation is controlled by a chrome-plated trigger contoured to fit comfortably into the driver's hand
- Extremely compact and lightweight for tight fit cockpit installation and weighs only 2.5 pounds
- Comes with factory installed neutral safety switch (back-up light switch is available separately)
- Controlled gate stop activation for positive feel
- One-hand operated, spring loaded reverse Loc/Out mechanism enables drivers to clear the reverse Loc/Out while remaining strapped in their shoulder harness belts
- Comes complete with hardware, 5' long shifter cable, and easy to follow installation guide
- Forged aluminum stick for added strength has 7/16-20 thread
- Optional covers (sold separately) found on page 7

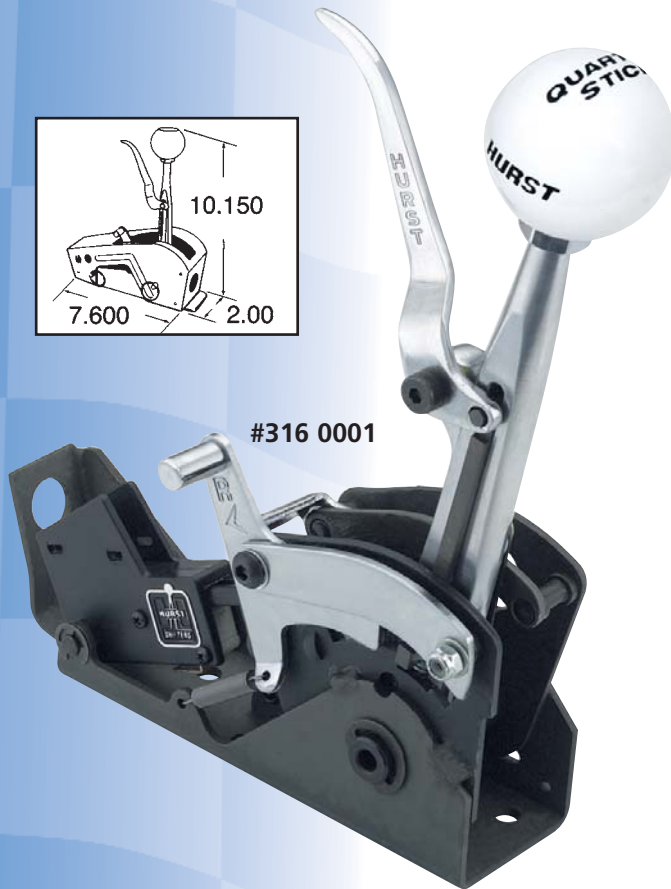
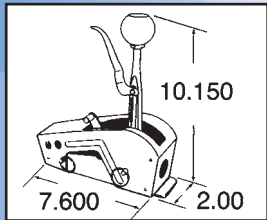

Console models are available for '73-'81 Camaros and '70-'81 Firebirds. Console model Quarter Sticks include a molded escutcheon plate with lighted gear position indicator, neutral safety and back-up light provisions and complete easy to follow installation guide.

APPLICATIONS

QUARTER STICK

Transmission	Valve Body	Trans. Code	Part No.
Powerglide (Alum. case only)	Forward & Rev.	245	316 0001
TH 250, 350, 375 & 400	Forward	242 & 243	316 0006
TH 250, 350, 375 & 400	Reverse	242 & 243	316 0001
TH 700 R4 & 200 4R	Forward	246 & 247	316 0030
Chrysler/AMC A727, A904	Forward	221, 222	316 0009
Ford C-4, C-6	Forward	231, 236	316 0009
Chrysler/AMC A727, A904	Reverse	221, 222	316 0014
Ford C-4, C-6	Reverse	231, 232	316 0014

QUARTER STICK CONSOLE MODEL

Make	Model	Year	Transmission	Part No.
Chevrolet	Camaro	73-81	TH 200, 350, 375, 400	316 0016
Pontiac	Firebird	70-81	TH 200, 350, 375, 400	316 0016

See page 51 for trans code information

See page 7 for optional Cover Kit kits

See page 46 for heavy-duty cables available in 3 ft., 4 ft., 5 ft., 8 ft., and 11 ft. lengths.

See page 41 for service parts.

AUTOMATIC SHIFTERS

PISTOL-GRIP QUARTER STICK®



The Hurst Pistol-Grip Quarter Stick Shifter is designed for a firm comfortable natural grip, providing a positive feel when shifting. This shifter has all of the same award winning features and qualities of our existing Quarter Stick automatic shifter, including controlled detent activation, one-hand operated spring loaded reverse Loc/Out mechanism, and neutral safety switch. The pistol-grip handle is CNC-machined from billet aluminum for exceptional strength, and features a precision snap-action switch that is ideal for operating a Hurst Roll/Control, nitrous system or trans brake.



A P P L I C A T I O N S

PISTOL-GRIP QUARTER STICK

Transmission	Valve Body	Trans. Code	Part No.
Powerglide (Alum. case only)	Forward & Reverse	245	316 2001
GM TH 250, 350, 375 & 400	Forward	242 & 243	316 2006
GM TH 250, 350, 375 & 400	Reverse	242 & 243	316 2001
GM TH 700R4 & 2004R	Forward	246, 247	316 2030
Chrysler/AMC A727, A904	Forward	221, 222	316 2009
Ford C-4, C-6	Forward	231, 236	316 2009
Chrysler/AMC A727, A904	Reverse	221, 222	316 2014
Ford C-4, C-6	Reverse	231, 232	316 2014

QUARTER STICK ACCESSORIES

SOLENOID SHIFTING KIT

The Hurst Electric Solenoid Shifting Kit is designed to automatically complete the 1st to 2nd gear change, increasing shifting reliability and improving E.T. consistency.

- Engineered for forward pattern Hurst Quarter Stick and Pistol-Grip shifters
- Shifting is controlled when used with an rpm activated switch or manually activated push button (normally open) switch.
- The solenoid features a spring activated plunger, and is designed to quickly and firmly push the shifter stick into gear, not "hit" or "slam" it, which can cause damage to the stick itself.
- Kit includes a H.D. 12-volt solenoid rated at maximum 3-amp draw to hold the plunger in position, aluminum mounting bracket, hardware, fuse and electrical connectors.



Part No. 226 0020



AUTOMATIC SHIFTERS

QUARTER STICK 2™ AND PISTOL GRIP 2™

Based on the original Quarter Stick technology, this ultimate drag racing shifter is ideal for rear engine dragsters.

- Rear exit cable for easier installation, positive shifts and less potential cable binding
- Designed for 2 and 3-speed transmissions in both forward and reverse valve body shift patterns
- Comes complete with hardware, and 5' long shifter cable, and easy to follow installation guide
- Forged aluminum stick for added strength has 7/16-20 thread (Quarter Stick)
- Other features are the same as the Quarter Stick Automatic Shifter
- Shown with optional cover 130 0056 (sold separately) found on page 7
- Positive reverse Loc/Out for NHRA and IHRA requirements



#316 0020

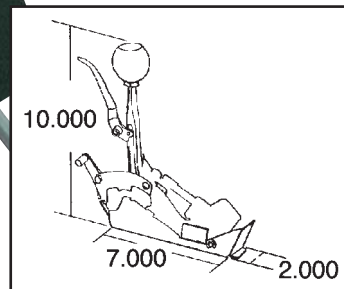

#316 2020

QUARTER STICK SHIFT GATE PATTERNS



Powerglide Reverse



Turbo Hydro Forward



Chrysler, Ford, AMC Forward



Turbo Hydro 4-Speed Forward



Turbo Hydro Reverse

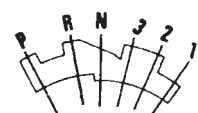

Chrysler, Ford, AMC Reverse

A P P L I C A T I O N S

Transmission	Valve Body	Trans. Code	QUARTER STICK 2	PISTOL GRIP 2
			Part No.	Part No.
Powerglide	Forward and Reverse	245	316 0020	316 2020
TH 250, 350, 375 & 400	Reverse	242 & 243	316 0020	316 2020
TH 250, 350, 375 & 400	Forward	242 & 243	316 0025	316 2025

See page 7 for optional Cover Kits.
 See page 51 for trans code information
 See page 41 for service parts

QUARTER STICK ACCESSORIES



ALUMINUM COVER KIT

Adds a professional finished look to your Quarter Stick or Pistol Grip installation. Attaches to shifter with quick release pins (included) and may be used in conjunction with the aluminum mounting plate kit. Does not fit Quarter Stick 2 or Pistol Grip 2.

Part No.	Description
130 0041	Aluminum Cover
189 0082	Replacement Pins



ALUMINUM MOUNTING PLATE KIT

Clear anodized aluminum mounting plate offers mounting flexibility and allows quick shifter removal via quick release pins (included).

Part No.	Description
195 0225	Mounting Plate
189 0082	Replacement Pins



COMPETITION SHIFTER KNOB WITH BUILT-IN 12 V SWITCH

Now with snap action for instant activation, this black molded ABS knob is ideal for use with Hurst Roll/Control®, trans brake, nitrous oxide systems or other 12 volt accessories.

Part No.	Thread Size	Application
163 0050	7/16 x 20	Quarter Stick and Lightning Rods for Lenco's



PLASTIC COVER KIT

Adds a distinctive finished look to your Quarter Stick™ installation. Mounting plate and button head screws are included with the plastic cover kit.

Part No.	Application
130 0055	Quarter Stick/Pistol Grip
130 0056	Quarter Stick 2/Pistol Grip 2

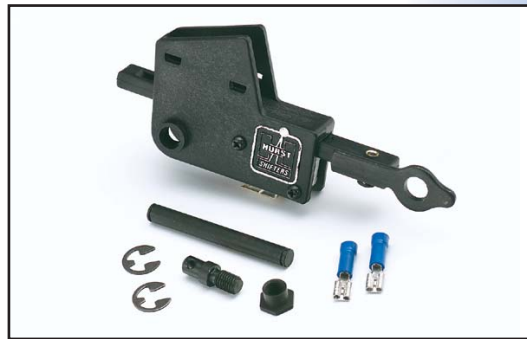

NEUTRAL/PARK START SAFETY SWITCH

Kit includes switch and mounting hardware. Easy installation for all existing Quarter Sticks. (Newer Quarter Sticks and Pistol Grip shifters feature the switch installed from the factory.) Fits front and rear exit cable shifters.

Part No.	Description
248 8600	Neutral Safety Switch



BACK-UP LIGHT SWITCH

Kit includes back-up light switch and hardware. Easy installation for all Quarter Stick and Pistol Grip shifters having front cable exit.

Part No.	Description
248 8601	Back-up light switch



T-HANDLE WITH BUILT-IN 12-VOLT SWITCH

The ideal command switch for use with Hurst Roll/Control, trans brakes, nitrous oxide systems or other 12 volt accessories. Now with new snap action button and switch for instant activation. Available in brushed aluminum finish only.

Part No.	Thread Size	Application
153 8510	7/16 x 20	Quarter Stick



AUTOMATIC SHIFTERS

AUTO/STICK 3®

An attractive and high-style, cable-operated ratchet type floor shifter for popular automatic transmissions. Designed for high performance racing applications, yet equally at home on the street.



#383 0012

- Delivers short precise gear changes through an exclusive dual pattern ratchet gear selector
- Operates both forward and reverse valve bodies, plus ratchet into neutral feature
- Ratchet mechanism may be overridden to reach any gear by pulling the stick up and moving it to desired position
- Sturdy black console with anodized aluminum trim plate and embossed with the familiar Hurst logo
- Includes bright chrome-plated stick and brushed aluminum T-handle (3/8-16 thread) for added comfort and control
- Includes 12-V switch assembly for neutral safety or back-up light connection
- Progressively illuminated gear position indicator.
- Complete with hardware, heavy-duty 5' shifter cable, and easy to follow installation guide
- Positive reverse Loc/Out for NHRA and IHRA requirements

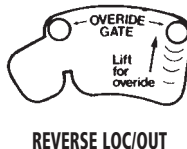
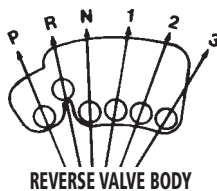
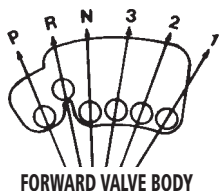
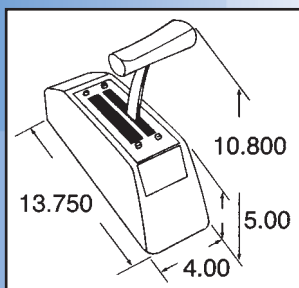

APPLICATIONS

AUTO/STICK 3

Make	Transmission	Trans. Code	Part No.
GM	TH 200, 250, 350, 375, 400	242, 243, 244	383 0012
Chrysler	Torqueflite A727-A904	221, 222	383 0012
Ford	C-4 and C-6	231, 232	383 0012
AMC	Torque Command A727-A904	221, 222	383 0012

See page 51 for trans code information.
See page 40 for service parts

AUTOMATIC SHIFTERS



DUAL/GATE 2®

Hurst's original dual function Gate-Type performance automatic floor shifter is now available to enthusiasts in a universal mount or a direct factory console bolt-in model.

- Contains both street and race gates to control either forward or reverse valve bodies
- Cable operation makes it ideal for street rods and other floorshift conversions
- Illuminated shift pattern indicator
- Attractive black textured console and chrome-plated trim plate with embossed Hurst logo
- Complete with hardware and an easy to follow installation guide
- Chrome-plated stick has 3/8-16 thread



Mechanically, the Dual/Gate 2 contains both street and race gates to control either forward or reverse valve bodies. The street gate duplicates stock factory shift sequence, while the race gate lets you control the gears manually, with fixed gate stops to help prevent overshifts. To change from street to race gate, activate the spring loaded access door and move the shift stick into neutral and over to the right or race gate side of the shifter. A custom fit Dual/Gate 2 is also available, designed to fit factory consoles in '73-'81 Camaros, '83-'92, and '70-'81 Firebirds.

NOTE: Includes one switch that can be used for either a back-up light switch or neutral safety switch.

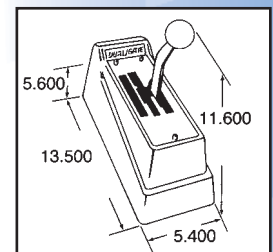

SHIFT PATTERNS



REVERSE VALVE BODY



FORWARD VALVE BODY

APPLICATIONS

DUAL/GATE 2

Make	Transmission	Trans. Code	Part No.
GM	TH 200, 250, 350, 375, 400	242, 243, 244	292 0006
Chrysler	Torqueflite A727-A904	221, 222	292 0007
Ford	C-4 and C-6	231, 232	292 0007
AMC	Torque Command A727-A904	221, 222	292 0007

DUAL/GATE 2 FACTORY CONSOLE MODELS

Make	Model	Year	Transmission	Trans. Code	Part No.
Chevrolet	Camaro	73-81	TH 200, 250, 350, 375, 400	242, 243, 244	292 0001*
Chevrolet	Camaro	83-92	TH 700 R4 and 200 4R	246, 247	292 0000
Pontiac	Firebird	70-81	TH 200, 250, 350, 375, 400	242, 243, 244	292 0001*

See page 51 for trans code information.
See page 40 for service parts

*Uses stock transmission cable.



AUTOMATIC SHIFTERS

STREET ROD SHIFTER

The Street Rod shifter is designed and quality-built by "America's Number One Shifter Company". Considering Hurst's reputation for reliability, it's no wonder why street rodders worldwide choose the Street Rod Shifter for their vehicles.

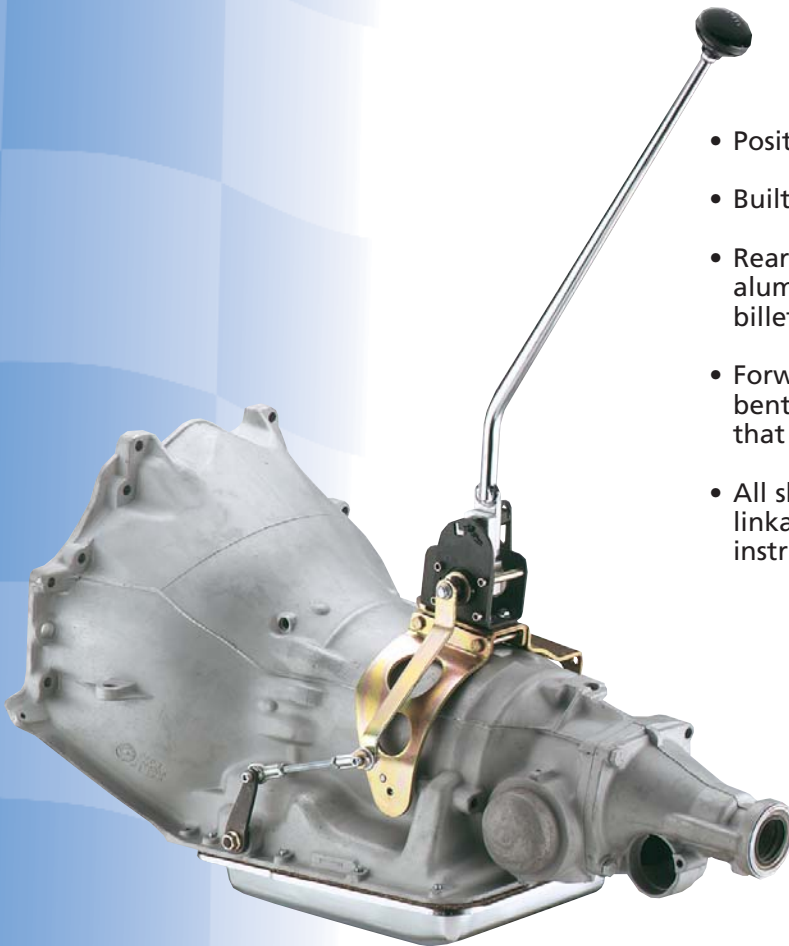

- Positive detent activation
- Built-in neutral/park start safety switch
- Rear mount shifter features a machined billet aluminum handle with an attractive 1/2-20 thread billet knob for that hi-tech look
- Forward mount shifter utilizes a chrome-plated bent stick and black 5/16-18 thread knob for the car that has a "Resto" look
- All shifters come complete with mounting brackets, linkage rod, installation hardware and detailed instruction sheet

#383 5690 FORWARD MOUNT

#383 5680 REAR MOUNT

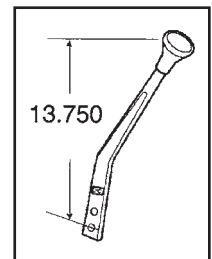
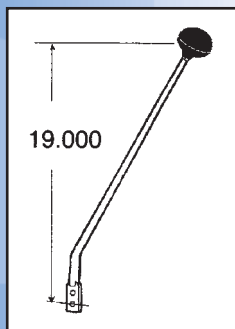

A P P L I C A T I O N S

STREET ROD SHIFTER

Transmission	Forward Mount with Chrome Resto-Style Stick	Rear Mount with Aluminum Handle
TH 200/350/400	383 5690	383 5680
TH 700R4	383 5691	383 5681

ACCESSORIES

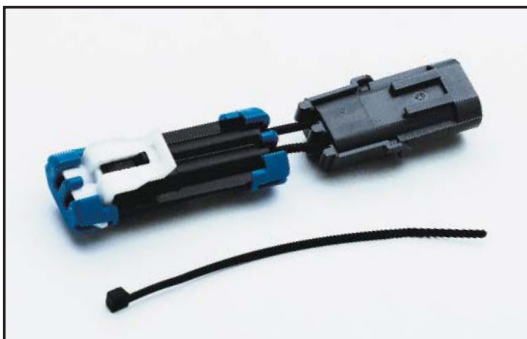

C.A.G.S. SKIP SHIFT ELIMINATOR KIT

A must for any performance enthusiast, the C.A.G.S. (computer aided gear selector) Skip Shift Eliminator Kit eliminates the annoying 1st to 4th mandatory gear change which occurs under pre-set engine rpm and mph conditions. This kit allows full 1st thru 6th gear changes at any speed, rpm or throttle position for maximum performance acceleration on vehicles having the 6-speed transmission. Easily installed and OBD II compatible.

Make/Model	Year	Trans.	Part No.
Chevrolet Camaro & Pontiac Firebird	98-02	BW T-56	155 0100
Chevrolet Corvette	92-96	ZF6	155 0100
Chevrolet Corvette	97	BW T-56	155 0100
Chevrolet Corvette	98-04	BW T-56	155 0120



ADJUSTABLE VACUUM MODULATOR

This modulator is adjustable, allowing you to tailor shift points within a range of 2-4 mph. Comes adjusted for normal shift points. Fits GM TH 350/400 Transmissions. Part No. 650 0001

Note: Adequate engine vacuum is required in order for the modulator to work properly. Inadequate vacuum can result in late or hard shifts.

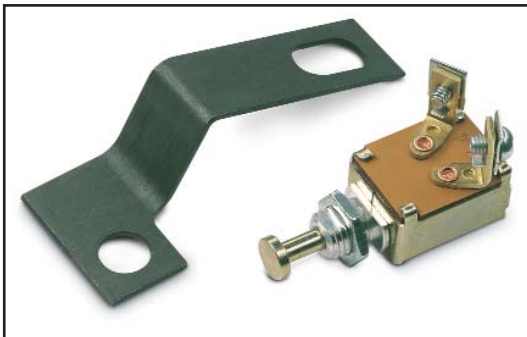

BACK-UP LIGHT SWITCH

This switch is designed to be used in conjunction with the OEM back-up lights and the Competition/Plus 4-Speed, Super/Shifter 3 and the Master Shift 3-Speed shifters. Part No. 248 0003



DOWNSHIFT SWITCH FOR GM TH 400

Designed to activate the electrically controlled GM TH 400 downshift, this kit is required when replacing a TH 700 R4, TH 200, or TH 350 transmission having a cable-operated downshift mechanism. Universal in design, the switch can easily be adjusted to provide precise control of the downshift timing. Installation is simple, as it uses the stock, OEM bracketry. The kit includes a heavy duty 12 volt switch, actuator rod, spring, and a detailed instruction sheet. Part No. 248 8605



COLUMN SHIFT CONVERSION AID FOR GM TRANSMISSIONS

For column shift conversion with GM TH 350, GM TH 400, GM 200 4R, and GM TH 700 R4, this transmission arm can be used in place of the Hurst #105 0080 making an easy connection to stock back drive rod, thus activating the neutral safety switch and the back-up lights. This eliminates the task of finding the correct wires to splice into. Note: Cannot be used on Pro-Matic 2, V-Matic 2 or Dual Gate. Part No. 105 0059



HURST EQUIPPED EMBLEM

Based on original HURST blueprints, this HURST EQUIPPED emblem is an authentic reproduction of the one used on the late '60's muscle cars equipped with a factory Hurst shifter. Made of durable ABS plastic with 3M adhesive tape backing for permanent mounting. Nominal size is 1-1/4" high by 5-1/4" long. Individually packaged. Part No. 136 1000



MANUAL SHIFTERS

BILLET/PLUS™ 5 & 6-SPEED

Hurst Billet/Plus Shifters incorporate a high ratio pivot mechanism for reduced shifter throw and are sturdily constructed for a more positive precise feel when shifting. Self centering alignment improves 2nd to 3rd up-shift gear changes to reduce the chance of "missed shifts". Patented adjustable bias spring loads on most models allow stick tension to be tailored to drivers preference. Dedicated applications assure a custom fit and eliminate any vehicle modifications for ease of installation.

- CNC machined 6061 T-6 BILLET ALUMINUM base and stop collar
- Heat treated BILLET STEEL gear selector for ultimate strength
- High strength steel stick. NOT A CASTING!
- Adjustable positive gear stops to help prevent internal transmission damage
- Stainless steel rotating pivot insures smooth shifting and reduced wear
- Polymide pivot cup reduces stick vibration and noise transfer
- Self centering alignment for improved 2nd to 3rd upshift gear changes
- Patented adjustable bias spring load for ease of operation
- Exclusive oil control seal, on most models, to eliminate trans fluid loss and protect against contamination
- US Patent no. 4,581,951

See pages 14-17 for Billet/Plus applications



391 5042



391 5085



391 5031

NEW

BILLET/PLUS SST SHIFTER

This 5-speed racing shifter features a super short throw for quicker shifts. Self-centering alignment improves 2nd to 3rd up-shift gear changes to reduce the chance of "missed shifts". The shifter incorporates gear stops to help prevent internal transmission damage, and the easily adjustable bias springs allow stick tension to be tailored to driver's preference. Constructed of CNC-machined 6061 T-6 BILLET ALUMINUM mounting base and heat-treated BILLET STEEL gear selector for ultimate strength. Features the traditional Hurst chrome-plated stick and classic white knob.



A P P L I C A T I O N S

BILLET/PLUS SST SHIFTER

Make/Model	Year	Engine	Transmission	Part No.
Ford Mustang	1983-01	5.0L/4.6L V8	BW T5, T45	391 5071

MANUAL SHIFTERS



COMPETITION/PLUS®

The industry standard for over 30 years, this shifter offers state of the art transmission control for popular 4, 5 & 6-speed manual transmissions. Dedicated applications assure a custom fit to a wide variety of vehicles having factory consoles without any floor pan modifications.

- Race track proven design and reliability.
- Heat treated linkage rods and arms for added strength and durability.
- Adjustable gear stops prevent overshifts to help prolong transmission life.
- Bolt-on chrome-plated stick with attractive custom white knob.
- Complete with all hardware and easy to follow installation guide.



Optional Hurst Super Boot & plate #114 7494 recommended for finished appearance. See page 37 for other boot styles available.

APPLICATIONS FOR MANUAL SHIFTERS

Model	Year	Description	Trans(3) Code	Transmission	Shifter Only	Installation Kit Only	Shifter & Kit Complete	
BUICK								
GRAN	65	w & w/o Console	451	Muncie	391 7308	373 3163	291 6516	
SPORT	66-67	w & w/o Console	441	Saginaw	391 7307	373 4297		
SKYLARK	65	w & w/o Console	451	Muncie	391 7308	373 3163	291 6516	
SPECIAL	66-67	w & w/o Console	441	Saginaw	391 7307	373 4297		
CHEVROLET								
FULL SIZE	55-57	All	410	BW T-10	391 3780	373 4734		
FULL SIZE	55-57	All	454	RICHMOND/BW T-10	391 3780	373 8609		
FULL SIZE	55-57	All	452/453	MUNCIE	391 3780	373 7834		
FULL SIZE	55-57	All	441	SAGINAW	391 3780	373 7919		
FULL SIZE	55-57	All	451	MUNCIE	391 3780	373 3163	291 6387	
FULL SIZE	58-59	All	410	BW T-10	391 7307	373 3157		
FULL SIZE	60-63	w & w/o Console	410	BW T-10	391 7308	373 4734		
FULL SIZE	63-64	w & w/o Console	451	MUNCIE	391 7308	373 3163	291 6516	
CAMARO	67-68	w & w/o Console	441	SAGINAW	391 4339	373 4531		
CAMARO	67-68	w & w/o Console	451	MUNCIE	391 4339	373 4529	291 6561	
CAMARO	69	w & w/o Console	452	MUNCIE	391 7438	373 7437		
CAMARO	70-72	w & w/o Console	453	MUNCIE	391 6848	373 7897		
CAMARO	73-74	w/Console	453	MUNCIE	391 8791	373 8605		
CAMARO	73-77	w/Console	441	SAGINAW	391 7438	373 8607		
CAMARO	74-81	w/o Console	454	BW	391 8794	373 8609		
CAMARO	74-81	w/Console	454	BW	391 8791	373 8609	291 8488	
CAMARO	82	w/Console	455	BW T-10(TT)	391 7960	373 0021		
CAMARO	82	w/Console	456	SAGINAW(TT)	391 7960	373 0022		

(1) Black anodized round steel stick - uses stock factory boot. (2) Injected molded top plate, boot, chrome plated steel flat stick short throw, vibration insulators included. (3) See pages 53-55 for trans code information. (4) Supplied with black steel stick without knob, threaded for factory knob. (5) Supplied with chrome-plated steel stick and black knob. (6) Not Required. (7) Black aluminum stick w/Black knob (*TT) - Torque Tube Tailhousing. *Modification to stick may be necessary to clear seat. A Hurst Super Boot is recommended for a professional looking installation. (Pt # 114 7494)



APPLICATIONS FOR MANUAL SHIFTERS



Model	Year	Description	Trans(3) Code	Transmission	Shifter Only	Installation Kit Only	Shifter & Kit Complete
CHEVROLET (CONTINUED)							
CAMARO	83-92	V6/V8	464	BW T-5	391 5032 (7) Billet/Plus	(6)	
CAMARO	93-02	V6	464	BW T-5	391 5032 (7) Billet/Plus	(6)	
CAMARO	93-02	V8	468	BW T-56	391 5060 (4) Billet/Plus	(6)	
CAMARO	93-02	V8	468	BW T-56	391 5061 (5) Billet/Plus	(6)	
CHEVELLE & MALIBU	64-67	w & w/o Console	451	MUNCIE	391 7308	373 3163	291 6516
CHEVELLE & MALIBU	66-67	w & w/o Console	441	SAGINAW	391 7307	373 4297	
CHEVELLE & MALIBU	68	w & w/o Console	451	MUNCIE	391 8014	373 3163	
CHEVELLE & MALIBU	68-72	w & w/o Console	441	SAGINAW	391 7930	373 7919	
CHEVELLE & MALIBU	69-72	w & w/o Console	452/453	MUNCIE	391 8014	373 7834	291 7835
CHEVELLE & MALIBU	73-74	w & w/o Console	453	MUNCIE	391 6848	373 7897	
CHEVELLE & MALIBU	78-79	w & w/o Console	441	SAGINAW	391 8794	373 0017	
CHEVY II & NOVA	64	w & w/o Console	451	MUNCIE	391 7308	373 3163	291 6516
CHEVY II & NOVA	65-67	w & w/o Console	451	MUNCIE	391 7308	373 4354	
CHEVY II & NOVA	68	w/Console	451	MUNCIE	391 4339	373 4529	291 6561
CHEVY II & NOVA	68	w/o Console	451	MUNCIE	391 6848	373 4529	
CHEVY II & NOVA	69-70	w/o Console	452	MUNCIE	391 6848	373 7131	
CHEVY II & NOVA	71-73	w/o Console	453	MUNCIE	391 6848	373 7834	
CORVETTE	57-62	All	410	BW T-10	391 7535	373 3157	
CORVETTE	63-67	All	451	MUNCIE	391 7960	373 3162	
CORVETTE	68	All	451	MUNCIE	391 7992	373 4648	
CORVETTE	69-79	All	452/453 & 454	MUNCIE & BW	391 7992	373 8611	291 8487
CORVETTE	80-81	All	454	BW T-10	391 0028	373 8621	
CORVETTE C4	89-96	V8		ZF6	391 5084 (4) Billet/Plus	(6)	
CORVETTE C5	97-04	V8		BW T-56	391 5085 (4) Billet/Plus	(6)	
1/2 TON, 3/4 TON	98-03	w & w/o Console	466	NEW VENTURE 3500	391 0122 (5)	(6)	
1/2 TON CHEVROLET & GMC PICKUPS	[Custom installation when using passenger car transmissions]		451	MUNCIE	391 0002	373 3163*	
			452/453	MUNCIE	391 0002	373 7834*	
			454	RICHMOND/BW T-10	391 0002	373 8609*	
			410	BW T-10	391 0002	373 4734*	
			441	SAGINAW	391 0001	373 7919*	
C-K SERIES TRUCKS	88-92	w/o Console	466	NEW VENTURE 3500	391 0120 (5)	(6)	
1/2 ton, 3/4 ton	93-97	w/o Console	466	NEW VENTURE 3500	391 0121 (5)	(6)	
S SERIES TRUCKS	82-92	4-Cyl	464/465	BW T-4, T-5	391 0029 (4)	(6)	
	95-03	4-Cyl	466	NEW VENTURE 1500	391 0112 (5)	(6)	
	91-94	6-Cyl	466	NEW VENTURE 3500	391 0110 (5)	(6)	
	95-97	6-Cyl	466	NEW VENTURE 3500	391 0111 (5)	(6)	
	98-03	6-Cyl	466	NEW VENTURE 3500	391 0113 (5)	(6)	
EL CAMINO	59	All	410	BW T-10	391 7307	373 3157	
EL CAMINO	64-67	w & w/o Console	451	MUNCIE	391 7308	373 3163	291 6516
EL CAMINO	66-67	w & w/o Console	441	SAGINAW	391 7307	373 4297	
EL CAMINO	68	w & w/o Console	451	MUNCIE	391 8014	373 3163	
EL CAMINO	68-72	w & w/o Console	441	SAGINAW	391 7930	373 7919	
EL CAMINO	69-72	w & w/o Console	452/453	MUNCIE	391 8014	373 7834	291 7835
EL CAMINO	74	w/Console	453	MUNCIE	391 6848	373 7897	
EL CAMINO	78-80	w & w/o Console	441	SAGINAW	391 8794	373 0017	
MONTE CARLO	70-72	w & w/o Console	452/453	MUNCIE	391 8014	373 7834	291 7835
MONTE CARLO	78-80	w & w/o Console	441	SAGINAW	391 8794	373 0017	

(1) Black anodized round steel stick - uses stock factory boot. (2) Injected molded top plate, boot, chrome plated steel flat stick short throw, vibration insulators included. (3) See pages 53-55 for trans code information. (4) Supplied with black steel stick without knob, threaded for factory knob. (5) Supplied with chrome-plated steel stick and black knob. (6) Not Required. (7) Black aluminum stick w/Black knob (*TT)- Torque Tube Tailhousing. *Modification to stick may be necessary to clear seat. A Hurst Super Boot is recommended for a professional looking installation. (Pt # 114 7494)

APPLICATIONS FOR MANUAL SHIFTERS



Model	Year	Description	Trans(3) Code	Transmission	Shifter Only	Installation Kit Only	Shifter & Kit Complete	NEW
CHRYSLER								
FULL SIZE	64-67	w/o Console	422	N. PROCESS	391 6788	373 4089	291 6550	NEW
	66-67	w/Console	422	N. PROCESS	391 6790	373 4089	291 6558	NEW
DODGE								
CHARGER	66-72	w/o Console	422	N. PROCESS	391 6789	373 4089	291 6551	NEW
CHARGER	66-69	w/Console	422	N. PROCESS	391 6790	373 4089	291 6558	NEW
CORONET & SUPER BEE	65-72	w/o Console	422	N. PROCESS	391 6789	373 4089	291 6551	NEW
CORONET & SUPER BEE	65-69	w/Console	422	N. PROCESS	391 6790	373 4089	291 6558	NEW
DAKOTA	94-00	V8	466	NV3500	391 0155 (5)	(6)		
DAKOTA*	94-99	V6		AX 15	391 5050 (5) Billet/Plus	(6)		
DAKOTA*	90-96	I-4		AX 15	391 5050 (5) Billet/Plus	(6)		
FULL SIZE	64-69	w/o Console	422	N. PROCESS	391 6788	373 4089	291 6550	NEW
	65-69	w/Console	422	N. PROCESS	391 6790	373 4089	291 6558	NEW
VIPER	92-02	V10	468	BW T-56	391 5055 (1) Billet/Plus	(6)		
FORD								
FULL SIZE	62-64	w & w/o Console	411	BW T-10	391 6848	373 3166		
FULL SIZE	64	w/Console	431	FORD T & C	391 6848	373 3167		
FULL SIZE	64-65	w/o Console	431	FORD T & C	391 6848	373 3167		
FAIRLANE & TORINO	64-65	w/o Console	431	FORD T & C	391 6848	373 3167		
FAIRLANE & TORINO	66-69	w & w/o Console	433	FORD T & C	391 3180	373 7638		
FAIRLANE & TORINO	70-71	w & w/o Console	433	FORD T & C	391 3180	373 7638		
FAIRLANE & TORINO	72-73	w & w/o Console	433	FORD T & C	391 3180	373 5587	291 6557	NEW
FALCON	66-67	8 Cyl. w & w/o Cons.	433	FORD T & C	391 3180	373 7638		
FALCON	63-65	8 Cyl. w & w/o Cons.	412	BW T-10	391 8789	373 3164		
MUSTANG	65-69	289, 302, 351 V-8 w & w/o Console	432	FORD T & C	391 3180	373 7637	291 7634	NEW
MUSTANG	65-69	289, 302, 351 V-8 w & w/o Console	413	BW T-10	391 3180	373 3668		
MUSTANG	67-69	390, 428, 429 V-8 w & w/o Console	433	FORD T & C	391 3180	373 5587	291 6557	NEW
MUSTANG	70-73	302, 351 V-8 w & w/o Console	432	FORD T & C	391 3180	373 7637	291 7634	NEW
MUSTANG	83-93	w/Console	465	BW T-5	391 0030 (1)	(6)		
MUSTANG	83-93	V6/V8	465	BW T-5	391 5030 (4) Billet/Plus	(6)		
MUSTANG	84-86	w/Console	465	BW T-5	391 0035 (2)	(6)		
MUSTANG	83-86	w/Console	465	BW T-5	538 0035 Comp Stick Kit-See page 17 for details			
MUSTANG	87-93	w/Console	465	BW T-5	391 0036 (2)	(6)		
MUSTANG	87-92	w/Console	465	BW T-5	538 0036 (7) Comp Stick Kit-See page 17 for details			
MUSTANG	83-93	w/Console	469	TREMEC 3550 & TKO	391 0070 (1)	(6)		
MUSTANG	83-93		469	Tremec 3550 & TKO	391 5070 (4) Billet/Plus	(6)		
MUSTANG	83-98	V8		BW T56 (aftermarket)	391 5072 (4) Billet/Plus	(6)		
MUSTANG	94-97	w/Console	465	BW-T-5	391 0031 (1)	(6)		
MUSTANG	94-01	V6/V8	465	BW T-5 , T-45	391 5031 (4) Billet/Plus	(6)		
MUSTANG	2001-04	V8		Tremec 3650	391 5035 (4) Billet/Plus	(6)		
MUSTANG COBRA	2003-04	4.6L V8 DOHC	468	BW T-56	391 5036 (4) Billet/Plus	(6)		
THUNDERBIRD	83-91	w/Console	465	BW T-5	391 0031 (1)	(6)		
THUNDERBIRD	83-91	V6/V8	465	BW T-5	391 5031 (4) Billet/Plus	(6)		

(1) Black anodized round steel stick - uses stock factory boot. (2) Injected molded top plate, boot, chrome plated steel flat stick short throw, vibration insulators included. (3) See pages 53-55 for trans code information. (4) Supplied with black steel stick without knob, threaded for factory knob. (5) Supplied with chrome-plated steel stick and black knob. (6) Not Required. (7) Black aluminum stick w/Black knob (*TT) - Torque Tube Tailhousing. *Modification to stick may be necessary to clear seat. A Hurst Super Boot is recommended for a professional looking installation. (Pt # 114 7494)



APPLICATIONS FOR MANUAL SHIFTERS



Model	Year	Description	Trans(3) Code	Transmission	Shifter Only	Installation Kit Only	Shifter & Kit Complete
FORD (CONTINUED)							
RANCHERO	63-65	8 Cylinder w & w/o Console	412	BW T-10	391 8789	373 3164	
RANCHERO	66-69	8 Cylinder w & w/o Console	433	FORD T & C	391 3180	373 7638	
RANCHERO	70-71	w & w/o Console	433	FORD T & C	391 3180	373 7638	
RANCHERO	72-73	w & w/o Console 6 & 8 Cylinder	433	FORD T & C	391 3180	373 5587	291 6557
1/2 TON TRUCK	78-79	Custom installation	3 + 1	FORD OD	391 0024	373 8620*	
		of passenger car transmission	431	FORD T & C	391 0001	373 3167*	
RANGER	88-03	V6/4cyl		5 speed manual	391 5020 (5) Billet/Plus	(6)	
F-150	88-96	6 Cyl/V8		5 speed M5OD	391 5025 (5) Billet/Plus	(6)	
F-150	97-03	6 Cyl/V8		5 speed M5OD	391 5026 (5) Billet/Plus	(6)	
JEEP							
WRANGLER	87-04	I-4		AX-5	391 5043 (5) Billet/Plus	(6)	
WRANGLER	90-98	I-6		AX-15	391 5040 (5) Billet/Plus	(6)	
WRANGLER	99-04	I-4/I-6	466	NV-1500/3500	391 0140 (5)	(6)	
CJ-SERIES*	82-86	I-6		BW T4/T5	391 5045 (5) Billet/Plus	(6)	
CHEROKEE	89-99	I-6		AX-15	391 5042 (5) Billet/Plus	(6)	
MERCURY							
FULL SIZE	61-64	w/Console	411	BW T-10	391 6848	373 3166	
FULL SIZE	64	w/Console	431	FORD T & C	391 6848	373 3167	
FULL SIZE	64-65	w/o Console	411	FORD T & C	391 6848	373 3167	
COMET & CYCLONE	66-69	w & w/o Console	433	FORD T & C	391 3180	373 7638	
	63-65	w & w/o Console V8	412	BW T-10	391 8789	373 3164	
COUGAR	67-68	289, 302 V-8 w & w/o Console	413	BW T-10	391 3180	373 3668	
COUGAR	67-69	289, 302, 351 V-8 w & w/o Console	432	FORD T & C	391 3180	373 7637	291 7634
COUGAR	67-69	390, 428, 429 V-8 w & w/o Console	433	FORD T & C	391 3180	373 5587	291 6557
COUGAR	83-91	w/Console	465	BW T-5	391 0031 (1)	(6)	
COUGAR	83-91	V6/V8	465	BW T-5	391 5031 (4) Billet/Plus	(6)	
CAPRI	83-87	w/Console	465	BW T-5	391 0030 (1)	(6)	
CAPRI	83-86	w/Console	465	BW T-5	391 0030 (1)	(6)	
OLDSMOBILE							
F-85	64-65	w & w/o Console	451	MUNCIE	391 7308	373 3163	291 6516
F-85	66	w/o Console	451	MUNCIE	391 7308	373 3163	291 6516
442	64-65	w & w/o Console	451	MUNCIE	391 7308	373 3163	291 6516
442	66	w/o Console	451	MUNCIE	391 7308	373 3163	291 6516
442	78-79	w & w/o Console	441	SAGINAW	391 8794	373 0017	
CUTLASS	78-79	w & w/o Console	441	SAGINAW	391 8794	373 0017	

(1) Black anodized round steel stick - uses stock factory boot. (2) Injected molded top plate, boot, chrome plated steel flat stick short throw, vibration insulators included. (3) See pages 53-55 for trans code information. (4) Supplied with black steel stick without knob, threaded for factory knob. (5) Supplied with chrome-plated steel stick and black knob. (6) Not Required. (7) Black aluminum stick w/Black knob (*TT) - Torque Tube Tailhousing. *Modification to stick may be necessary to clear seat. A Hurst Super Boot is recommended for a professional looking installation. (Pt # 114 7494)

APPLICATIONS FOR MANUAL SHIFTERS



Model	Year	Description	Trans(3) Code	Transmission	Shifter Only	Installation Kit Only	Shifter & Kit Complete	NEW
PLYMOUTH								
FULL SIZE	64-69	w/o Console	422	N. PROCESS	391 6788	373 4089	291 6550	NEW
FULL SIZE	66-69	w/Console	422	N. PROCESS	391 6790	373 4089	291 6558	NEW
BELVEDERE & GTX	65-72	w/o Console	422	N. PROCESS	391 6789	373 4089	291 6551	NEW
BELVEDERE & GTX	66-69	w/Console	422	N.PROCESS	391 6790	373 4089	291 6558	NEW
ROADRUNNER	68-72	w/o Console	422	N. PROCESS	391 6789	373 4089	291 6551	NEW
ROADRUNNER	68-69	w/Console	422	N. PROCESS	391 6790	373 4089	291 6558	NEW
PONTIAC								
FULL SIZE	60-64	w/o Console	410	BW T-10	391 7308	373 4734		
FIREBIRD	67-68	w & w/o Console	441	SAGINAW	391 4339	373 4531		
FIREBIRD	67-68	w & w/o Console	451	MUNCIE	391 4339	373 4529	291 6561	NEW
FIREBIRD	69	w & w/o Console	452	MUNCIE	391 7438	373 7437		
FIREBIRD	70-72	w & w/o Console	452/453	MUNCIE	391 6848	373 7897		
FIREBIRD	74-81	w/o Console	454	BW T-10	391 8794	373 8609		
FIREBIRD	74-81	w/Console	454	BW T-10	391 8791	373 8609	291 8488	NEW
FIREBIRD	82	w/Console	455	BW T-10(TT)	391 7960	373 0021		
FIREBIRD	82	w/Console	456	SAGINAW(TT)	391 7960	373 0022		
FIREBIRD	83-92	V6/V8	464	BW T-5	391 5032 (7) Billet/Plus	(6)		
FIREBIRD	93-02	V6	464	BW T-5	391 5032 (7) Billet/Plus	(6)		
FIREBIRD	93-02	V8	468	BW T-56	391 5060 (4) Billet/Plus	(6)		
FIREBIRD	93-02	V8	468	BW T-56	391 5061 (5) Billet/Plus	(6)		
GRAND PRIX	78-79	w & w/o Console	441	SAGINAW	391 8794	373 0017		
G.T.O	64-66	w/o Console	451	MUNCIE	391 7308	373 3163	291 6516	NEW
TEMPEST & LEMANS	64-66	w/o Console	451	MUNCIE	391 7308	373 3163	291 6516	NEW
TEMPEST & LEMANS	66	w/o Console	441	SAGINAW	391 4339	373 4531		
TEMPEST & LEMANS	78-79	w & w/o Console	441	SAGINAW	391 8794	373 0017		
VENTURA II	71-73	w/o Console	453	MUNCIE	391 6848	373 7834		
SHELBY MUSTANG								
GT-350	65-69	w & w/o Console	413	BW T-10	391 3180	373 3668		
GT-500	67-69	w & w/o Console	433	FORD T & C	391 3180	373 5587	291 6557	NEW
STUDEBAKER								
HAWK	59-64	w/Bucket Seats	410	BW T-10	391 7308	373 4734		

(1) Black anodized round steel stick - uses stock factory boot. (2) Injected molded top plate, boot, chrome plated steel flat stick short throw, vibration insulators included. (3) See pages 53-55 for trans code information. (4) Supplied with black steel stick without knob, threaded for factory knob. (5) Supplied with chrome-plated steel stick and black knob. (6) Not Required. (7) Black aluminum stick w/Black knob (*TT) - Torque Tube Tailhousing. *Modification to stick may be necessary to clear seat. A Hurst Super Boot is recommended for a professional looking installation. (Pt # 114 7494)

COMP STICK FOR MUSTANG T-5 TRANSMISSION

Hurst now has available a competition stick kit for the 1983-92 Ford Mustang equipped with a Borg-Warner T-5 manual transmission. The Comp Stick Kit fits the stock OEM shifter mechanism and aftermarket Hurst Competition Plus shifter mechanism. Each kit consists of a white shift knob with gear shift pattern, chrome-plated flat shifter stick, rubber vibration isolater, shifter boot, and console top plate with the famous Hurst shifter logo.

Year	Description	Comp. Stick Kit
1983-86	Mustang w/factory Console & T-5 Trans	538 0035
1987-93	Mustang w/factory Console & T-5 Trans	538 0036





TRUCK SHIFTERS

COMPETITION/PLUS® & BILLET/PLUS™

The traditional Hurst Competition/Plus Shifter and Billet/Plus series shifters are now available for many later model pick-up trucks equipped with manual transmissions. This shifter is designed to provide a more positive and secure feel when shifting and incorporates a high ratio pivot mechanism for approximately 30% reduced knob travel resulting in shorter, quicker shifts. Patented adjustable bias spring loads allow stick tension to be tailored for driver's preference, and positive gear stops prevent overshifting and internal transmission damage. Supplied with chrome plated bolt-on stick with black knob and easily installed without any vehicle modifications. U.S. Patent No. 4,581,951.



391 5045



#391 0112



391 0155



391 0110

APPLICATIONS

COMPETITION/PLUS

Make	Model	Year	Engine	Transmission	Trans. Code	Shifter
Chevy/GMC	CK-Series 1/2 & 3/4 Ton	88-93	V6/V8	New Venture MG-5 3500	466	391 0120
Chevy/GMC	CK-Series 1/2 & 3/4 Ton	94-97	V6/V8	New Venture MG-5 3500	466	391 0121
Chevy/GMC	CK-Series 1/2 & 3/4 Ton	98-03	V6/V8	New Venture MG-5 3500	466	391 0122
Chevy/GMC	S10/S15 Series	82-94	4-Cyl	Borg-Warner T4, T5	464	391 0029 (4)
Chevy/GMC	S10/S15 Series	91-94	V6	New Venture 3500	466	391 0110
Chevy/GMC	S10/S15 Series	95-03	4-Cyl	New Venture 1500	466	391 0112
Chevy/GMC	S10/S15 Series	95-97	V6	New Venture 3500	466	391 0111
Chevy/GMC	S10/S15 Series	98-03	V6	New Venture 3500	466	391 0113
Dodge	Dakota	94-00	V8	NV3500	466	391 0155
Jeep	Wrangler	99-04	2.4L/4.0L	NV-1500/3500	466	391 0140

BILLET/PLUS

Make	Model	Year	Engine	Transmission	Trans. Code	Part No.
Dodge	Dakota	94-99	V6	AX 15		391 5050
Dodge	Dakota	90-96	I-4	AX 15		391 5050
Jeep	Wrangler	90-98	I-6	AX-15		391 5040
Jeep	Wrangler	87-04	I-4	AX-5		391 5043
Jeep	CJ-Series	82-86	I-6	BW T4/T5		391 5045
Jeep	Cherokee	89-99	I-6	AX-15		391 5042
Ford	Ranger	88-03	4-Cyl/V6	5 speed manual		391 5020
Ford	F-150	88-96	6-Cyl/V8	5 speed M50D		391 5025
Ford	F-150	97-03	6-Cyl/V8	5 speed M50D		391 5026

CUSTOM GM TRUCK APPLICATIONS 4-SPEED SHIFTERS

Model	Description	Trans. Code	Transmission	Shifter	Installation Kit
1/2 Ton Chevrolet & GMC Pick-ups	Custom installation when using passenger car transmissions. Modification to stick may be necessary to clear seat.	451	Muncie	391 0002	373 3163
		452	Muncie	391 0002	373 7834
		453	Muncie	391 0002	373 7834
		410	Borg-Warner	391 0002	373 4734
		441	Saginaw	391 0001	373 7919
		454	Richmond/BW Super T-10	391 0002	373 8609

STREET SUPER/SHIFTER™



4-SPEED

Based on the racing version of the legendary Super Shifter 3, the Hurst Street Super/Shifter brings many of the same quality features to a new level of performance.

- Utilizes a 7-1/2" tall chrome-plated stick (3/8-16 thread) for a short throw, 4-3/4" knob travel between gears.
- High mounting design assures proper linkage rod alignment.
- Heat treated components for extra strength and reliability.
- Adjustable gear stops to prevent overshifts.
- Complete with all necessary hardware and easy to follow installation guide.
- Shifter assembly and installation kit each sold separately.
- Optional bolt-on sticks available for custom vehicle applications. See pages 47-49

Optional Hurst Super Boot #114 7494 recommended for finished appearance and sold separately.

NOTE: Street Super/Shifters are not vehicle specific. They will fit the transmissions listed, but will not fit stock consoles and often require minor floor pan modification for installation.



#391 7535 Shifter
#373 8616 Installation Kit

A P P L I C A T I O N S

STREET SUPER SHIFTER

Transmission	Trans. Code	Shifter Only	Installation Kit
MUNCIE	451	391 7535	373 8616
MUNCIE	452, 453	391 7535	373 8616
BW T-10	410	391 7535	373 8616
RICHMOND/BW SUPER T-10	454	391 7535	373 8616
SAGINAW	441	391 7535	373 8618
NEW PROCESS	421	391 7535	373 8617
FORD T & C	432-433	391 7535	373 8615

See pages 53-55 for trans code information



MANUAL SHIFTERS

MASTERSHIFT™ 3-SPEED

Hurst's Mastershift 3-speed shifter is designed to provide precise gear selection and dependable long life. Popular as both a replacement floor shift and a column shift conversion.



#366 7271

- Exclusive advanced gear shift mechanism design for shorter throw and positive, precise shifts
- Heat treated components for durability and longer life
- Attractive chrome-plated steel stick with 3/8-16 thread and custom white knob
- Installation kits include all linkage, mounting hardware, shifter boot and easy-to-follow installation guide
- Shifter assembly and installation kit are each sold separately



#366 6809 Shifter

#367 0006 Installation Kit



MANUAL SHIFTERS

MASTERSHIFT™ APPLICATIONS



Model	Year	Description	Trans. Code	Trans.	Shifter Only	Installation Kit
BUICK						
GRAN SPORT & SPECIAL	66-67	6 & 8 Cylinder w/o Console	343	SAGINAW	366 7271	367 0010
CHEVROLET						
FULL SIZE	55-57	All	341	CHEVROLET	366 6901	367 3111
FULL SIZE	58-64	6 & 8 Cylinder w/o Console	341	CHEVROLET	366 7271	367 3111
FULL SIZE	66-70	6 & 8 Cylinder w/o Console	343	SAGINAW	366 6901	367 7143
CHEVELLE	66-72	6 & 8 Cylinder w/o Console	343	SAGINAW	366 7271	367 0010
CHEVELLE	73-74	6 & 8 Cylinder w/o Console	343	SAGINAW	366 7271	367 0010
EL CAMINO	59-60	6 & 8 Cylinder w/o Console	341	CHEVROLET	366 7271	367 3111
EL CAMINO	66-72	6 & 8 Cylinder w/o Console	343	SAGINAW	366 7271	367 7143
EL CAMINO	73-74	6 & 8 Cylinder w/o Console	343	SAGINAW	366 7271	367 0010
PICK-UP	55-66	All 1/2 Ton	341	CHEVROLET	366 6809	367 3112
PICK-UP	67-68	6 Cylinder Only 1/2 Ton	341	CHEVROLET	366 6809	367 3111
PICK-UP	67-68	8 Cylinder Only 1/2 Ton	343	SAGINAW	366 6809	367 7143
PICK-UP	69	6 & 8 Cylinder 1/2 Ton	343	SAGINAW	366 6809	367 7143
PICK-UP	69-87	All 1/2 & 3/4 Ton 2 Wheel Drive also Blazer & Suburban*	343/351	SAGINAW/MUNCIE	366 6809	367 0006
PICK-UP	69-77	All 4 Wheel Drive	343	SAGINAW	366 6901	367 0025
VAN	71-87	All 2 Wheel Drive	343/351 352	SAGINAW/MUNCIE TREMEC	366 0014	367 0023
FORD						
BRONCO	66-77	8 Cylinder - only	333	FORD T & C	366 6901	367 0013
MUSTANG	65-73	289, 302, 351 V-8 & w/o Console	336	FORD T & C	366 3179	367 7640
MUSTANG	65-73	6 Cylinder w & w/o Console	336/337	FORD	366 3179	367 7640
VAN	75-79	All	333/339	FORD T & C	366 6809	367 0014
PICK-UP 1/2 TON	63-87	All 2 Wheel Drive*	333	FORD	366 6809	367 0027
GMC						
VAN	71-81	6 & 8 Cylinder	343/351 352	SAGINAW, MUNCIE TREMEC	366 0014	367 0023
1/2 & 3/4 TON PICK-UP	68-81	All 2 Wheel Drive*	343	SAGINAW	366 6809	367 0006
	68-77	All 2 Wheel Drive*	351	MUNCIE	366 6809	367 0006
MERCURY						
COUGAR	67-69	289, 302, 351 V-8 w & w/o Console	336	FORD T & C	366 3179	367 7640
METEOR	63	8 Cylinder w/o Console	333	FORD T & C	366 3179	367 7640
OLDSMOBILE						
CUTLASS F-85 & 442	66-72	6 & 8 Cylinder w/o Console	343	SAGINAW	366 7271	367 0010
PONTIAC						
FULL SIZE	58-63	w/o Console	341	CHEVROLET	366 6901	367 3111
G.T.O. & TEMPEST	66-73	w & w/o Console	343	SAGINAW	366 7271	367 0010

*Modification to catalytic converter bracket may be necessary if vehicle is so equipped.
See pages 47-49 for custom stick selection.
See page 52 for trans code information.



MANUAL SHIFTERS

QUICK/STICK™

Hurst Quick/Stick shifters are designed exclusively for sport compact cars with manual transmissions. They put the fun back into shifting by reducing shift lever throw by 30% and by using better materials machined to closer tolerances to provide a more positive and precise shift.



- All Quick/Stick Shifters are CNC machined from billet steel and/or billet aluminum for extra strength
- Engineered as a direct bolt-in replacement shifter for a simple, easy installation
- Sticks accept the stock factory knob or most aftermarket custom shift knobs, in addition to the popular Hurst T-Handle



HURST QUICK/STICK		
Model & Year	Color	Part No.
Civic 1988-00	Black	391 4000
CRX 1988-91	Silver	391 4002
Acura Integra 1990-01	Blue	391 4004
	Purple	391 4008
Model	Year	Part No.
Dodge Neon	1994-2001	391 4015
Mitsubishi Eclipse	1995-1999	391 4025
Eagle Talon	1995-1997	391 4025
Chrysler Sebring	1995-1996	391 4025
Dodge Avenger	1995-1996	391 4025
Chrysler PT Cruiser	2001-03	391 4030
Chrysler PT Turbo	2003	391 4032



URETHANE SHIFTER STABILIZER KIT

This kit replaces the soft factory rubber shifter rod mount and bushing, providing a more positive feel of the shifter to help eliminate missed shifts under competition. A must when using the Hurst Quick/Stick Shifter or other aftermarket performance shifters. Easily installed.

Year/Model	Part No.
1990-01 Acura Integra	332 1000
1988-00 Honda Civic/CRX	332 1002
1984-87 Honda Civic/CRX	332 1000

INDY SHIFTERS

UNIVERSAL 4-SPEED



Hurst/Indy 4-Speed Shifter Kits are designed to be used on most popular 4-speed transmissions and a wide variety of cars. Applications are determined by transmissions and an exclusive engineered mounting design, making them adaptable to many popular passenger car floor pans.

- Adaptable to most popular passenger cars
- Narrow spring-loaded gate for ease of operation
- Heat-treated and plated parts for added strength and durability
- 7-1/2" tall chrome-plated stick (3/8-16 thread) provides short, precise throws
- Comes complete with all hardware, linkage and easy-to-follow instruction guide
- Optional bolt-on sticks available for custom vehicle applications. See pages 47-49

NOTE: The high mounting location of these kits often eliminates their use with factory consoles. Trim modifications to floor pans is often necessary.



Shown with optional Hurst Boot #114 8429 (recommended for a professional appearance)

APPLICATIONS

PART NO. 503 0030

- Transmission used as original equipment on pre-69 GM cars
- 7-bolt side cover
- Reverse shaft in extension housing
- Forward gear shifting shafts straight when trans in neutral
- Arms attach with stud and nut

PART NO. 503 0030

- Transmission used as original equipment in '69 and later cars
- 7-bolt side cover
- Reverse shaft in extension housing
- Forward gear shifting shafts straight when trans in neutral
- Arms attach with bolt

PART NO. 503 0030

- Transmission used as original equipment in '74 and later GM cars
- 9-bolt curved bottom side cover
- Reverse shaft in extension housing
- Forward gear shifting shafts straight when trans in neutral
- Arms attach with stud and nut

PART NO. 503 0030

- Standard T-10 used as original equipment in '58-'63 GM cars
- Super T-10 is an aftermarket replacement unit
- 9-bolt side cover
- Shifting shafts are on an angle when trans is in neutral

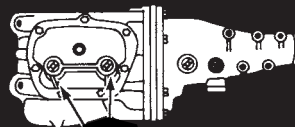

451 Muncie

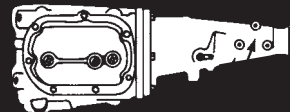

441 Saginaw

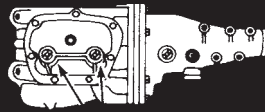

452, 453 Muncie



432, 433 Ford T & C

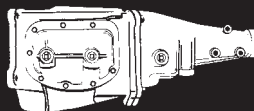

454 Borg Warner T-10, Super T-10 (AS9)

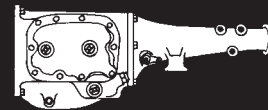

421 New Process

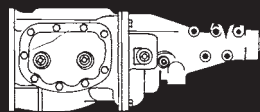

410 Borg Warner T-10, Super T-10 (AS3)

PART NO. 503 0033

- Transmission used as original equipment in GM cars
- All shifting shafts located on side cover
- 7-bolt side cover
- Arms attach with bolt

PART NO. 503 0031

- Transmission used as original equipment in '62 and later Ford Motor Corp. cars
- 10-bolt top cover
- All shifting shafts on side of main case
- Extension housing may have more than one shift mounting location

PART NO. 503 0032

- Transmission used in '66 and later small Chrysler Corp. cars (Demon, Duster, etc.)
- Reverse shaft in lower portion of main case
- 10-bolt side cover



INDY SHIFTERS

INDY MATIC 1

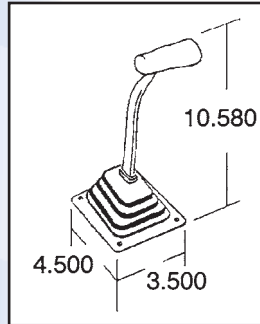

#506 0001

- Fits many popular 2 and 3-speed automatic transmissions
- Universal floor mount for easy installation, ideal for column shifter conversion
- Safety detented for precise shifting control
- Linkage rod activated
- All parts are plated for lasting protection
- Attractive chrome-plated stick with black T-handle for comfort shifting
- Complete with shifter boot, hardware and easy to follow installation guide
- Must use factory neutral safety switch



INDY MATIC 1

Make	Year
Chevrolet Powerglide	51-73
Buick TH 350 & 400, Chevrolet TH 350 & 400,	65-81
Oldsmobile TH 350 & 400 (except Toronado), Pontiac TH 350 & 400	65-81
Oldsmobile Turbo-Hydramatic, Pontiac Turbo-Hydramatic	49-60
Chrysler Torqueflite 727 & 904 (Dodge, Plymouth & Chrysler)	64-81
Ford & Mercury Cruise-o-matic DR, Ford & Mercury Ford-o-matic DR	58-81
Ford-o-matic SR	57-59

INDY PICK UP TRUCK 3-SPEED SHIFTER

This popular Indy shifter is available for pick-up trucks and is a perfect replacement for old floor shifters, or an ideal column shift conversion.

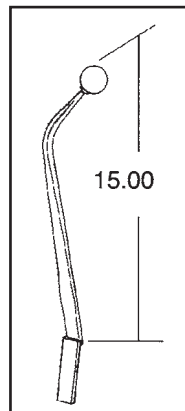

#501 0016

- Extended chrome-plated stick (uses 3/8-24 thread) to accommodate pick-up truck seat height
- Precise selector pin mechanism
- Spring loaded gate for positive shifts
- All parts plated for protection
- Stamped with Hurst/Indy identification
- Complete with all linkage, mounting hardware, and easy to follow installation guide
- Shown with optional Indy Boot & Plate #114 8429 recommended for finished appearance



INDY PICK-UP TRUCK

Make	Year
GENERAL MOTORS All two-wheel drive with Saginaw, Muncie & Tremec transmissions	69 & Later
FORD MOTOR CO. All two-wheel drive with Ford & Tremec transmissions	63 & Later

INDY 3-SPEED SHIFTERS



INDY QUALIFIER

- Economically priced
- Universal design - one part number fits most applications
- Ideal for column shift conversion
- Chrome-plated stick with black plastic knob
- All components plated for protection
- Complete with hardware and easy-to-follow installation guide
- Shown with optional Boot & Plate #114 7336

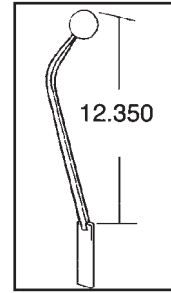

#501 0018



INDY QUALIFER #501 0018	
Make	Year
GM	
Buick*	64-Later
Chevrolet-Standard & H.D. 6 & 8 cylinder	55-Later
Chevelle, Camaro, Chevy II	62-Later
Oldsmobile-Standard & Intermediates*	49-Later
Pontiac-Standard & H.D.*	58-Later
Pontiac Firebird, Tempest & LeMans	64-Later
CHRYSLER	
Chrysler, Plymouth, DeSoto, Dodge, except A body Chryslers (Demon, Dart, Duster)	57-Later
FORD	
Ford-standard & H.D. 6 & 8 cylinder	49-Later
Falcon, Fairlane, Torino - 6 & 8 cylinder	62-Later
Lincoln	49-Later
Mercury-standard & H.D. 6 & 8 cylinder	49-Later
Meteor, Comet, Cougar - 6 & 8 cylinder	49-Later
PICK-UP TRUCKS	
3-spd. transmission standard & H.D. Ford, Chevrolet, GMC, Dodge (except '71 and later Dodge pick-up trucks).	55-Later

#501 0002

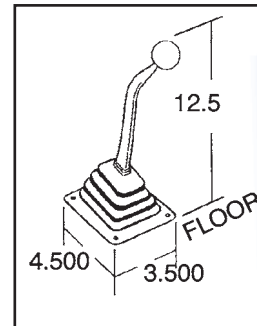

INDY SSA

- Spring loaded gate for ease of operation
- Short precise throws for less stick travel
- Attractive chrome-plated stick (3/8-24 thread) can be adjusted to different positions
- Ideal for floor shift replacement or column shift conversion
- Fits most popular passenger cars with 3-speed manual transmissions
- All components are plated for protection
- Complete with shifter boot, hardware and easy-to-follow installation guide

INDY SSA UNIVERSAL #501 0002	
Make	Year
GM	
Buick*	64-Later
Chevrolet-Standard & H.D. 6 & 8 cylinder	55-Later
Chevelle, Camaro, Chevy II	62-Later
Oldsmobile-Standard & Intermediates*	49-Later
Pontiac-Standard & H.D.*	58-Later
Pontiac Firebird, Tempest & LeMans	64-Later
CHRYSLER	
Chrysler, Plymouth, Dodge Standard & Intermediate (except Duster, Demon, Challenger)	57-Later
FORD	
Ford & Mercury Standard	49-Later
Fairlane, Montego, Torino, Meteor, Falcon, Comet	62-Later

* Note: Will fit all 6 cyl., HD and standard 3-speed transmissions except selector type gear boxes (single shaft). Certain applications require a great deal of modification to make shifter fit.



DRAG RACING SHIFTERS

V-GATE 2® IN-LINE SHIFTER

This original vertical gate in-line competition shifter is the most dependable 4 and 5 speed manual transmission shifter for drag racing. Drivers can maintain positive gear control and run consistently with simple straight push/pull movements.

- Built-in stops prevent overshifting and heavy-duty springs provide added performance dependability
- Internal mechanisms are heat treated for added strength and durability
- First gear incorporates a built-in lock out for added safety
- Separate lever for positive reverse Loc/Out
- Complete with Hurst aluminum T-Handle (3/8-16 thread) and easy to follow installation guide
- Installation kit and V-Gate 2 Boot #114 1653 sold separately

411 8156 Shifter
373 8190 Installation Kit



SHIFT PATTERNS

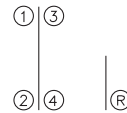

4-SPEED V-GATE 2 SHIFT PATTERN

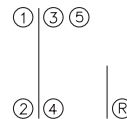

5-SPEED V-GATE 2 SHIFT PATTERN

APPLICATIONS

V-GATE 2

Make	Year	Transmission	Trans. Code	Shifter Only	Installation Kit
GM	74 & LATER	Richmond/BW T-10, 2nd design AS-9 Series	454	411 8156	373 8165
	ALL	BW T-10, 1st Design	410	411 8156	373 8190
	63-68	Muncie Arms Attached w/Stud & Nut	451	411 8156	373 8190
	69 & LATER	Muncie Arms Attached w/Bolt	452	411 8156	373 8190
	ALL	Saginaw 3 bolt Mounting Position in Extension Housing	441	411 8156	373 8164
FORD	65-75	BW T-10, Super T-10	415	411 8156	373 8174
	65-75	T & C Rear Location	432	411 8156	373 8172
	67-69	T & C	433	411 8156	373 8171
	70-75	T & C	434	411 8156	373 8175
MOPAR	-	New Process B-Body	422	411 8156	373 8182
	-	New Process A-Body	421	411 8156	373 8180
RICHMOND	-	Richmond/Doug Nash/G-Force 5-Speed	467	411 8157	373 8188
	-	Richmond/BW-T10 4-Speed	454	411 8156	373 8165
JERICO	-	Jerico 4-Speed	-	411 8156	373 8193

NOTE: Floor and console must be modified for shifter installation.

RECOMMENDED FOR USE WITH: Bucket seats or modified bench seat.

See service part section for component information. See pages 53-55 for trans code information.

DRAG RACING SHIFTERS



SUPER/SHIFTER 3

One of the most legendary Hurst Shifters ever engineered! Considering its impressive list of features, the Super Shifter 3 supports Hurst's well-earned reputation as "America's Number One Shifter."

- Incorporates a positive reverse Loc/Out mechanism that provides the most secure method of blocking the reverse gate ever offered
- Heat treated trans arms and internal mechanism components assure strength and durability
- Reinforced heat treated linkage rods eliminate flex
- Shifter rods and adjustable rod buttons are secured with special locking jam nut to provide more positive attachment and alignment
- Complete with hardware and easy to follow installation guide
- Chrome-plated stick has 3/8-16 thread
- Shifter and installation kit each sold separately

Optional Hurst shifter boot #114 0010 recommended for finished appearance



491 0001

A P P L I C A T I O N S

SUPER SHIFTER 3

Transmission	Trans. Code	Shifter Only	Installation Kit
MUNCIE	451	491 0001	373 0006
BW T-10	454	491 0001	373 0006
MUNCIE	452, 453	491 0001	373 0007
NEW PROCESS	422, 423	491 0001	373 0011
FORD T & C	432, 433	491 0001	373 0014

See pages 47-49 for custom stick selection.

See pages 53-55 for trans code information.



DRAG RACING SHIFTERS

RICHMOND 5-SPEED

Hurst offers state of the art shifter control for Richmond Street or Race 5-speed transmissions. These shifters offer the highest quality materials, workmanship and design in the industry today.

- Shifter mounts low and close to the transmission case for ease of installation in most applications
- Incorporates a neutral bias shift pattern that centers the stick to the 3-4 gate in neutral, requiring a bias effort to overcome the preload spring to enter the 1-2 or 5-R gate
- Built-in gear stops prevent overshifting
- Internal mechanism components are heat treated for strength and durability
- Reinforced heat treated 7/16" linkage rods eliminate flex
- Complete with installation kit and easy to follow installation guide
- Chrome-plated stick has 3/8-16 thread

NOTE: This shifter will also work with the earlier version transmission known as the Doug Nash 5-speed and the G-Force transmission.



407 0009

SHIFT PATTERN

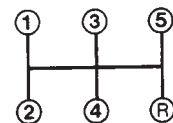

APPLICATIONS

RICHMOND 5-SPEED

Transmission	Trans. Code	Shifter & Installation Kit
Richmond Street & Race 5-Speed	467	407 0009
Richmond Street & Race 5-Speed	467	407 0015(1)

(1) Supplied with 7-1/2" stick #538 7238 See pages 47-49 for custom stick selection. See page 55 for trans code information.

DRAG RACING SHIFTERS

PRO V-GATE®



The Pro V-Gate 5 shifter is the winning choice for Pro-Stock, Comp Eliminator and Mustang Shootout classes.

This shifter features a one piece billet aluminum handle for superior strength, and provides a comfortable natural feel when shifting, allowing less chance of your hand slipping off a ball. The unique pistol grip handle provides a much more secure grip for precise, positive shifts. The gate trigger is designed and positioned to be quickly and easily pulled back with the same hand used for shifting, allowing quick engagement into 1st gear. A built-in Roll/Control switch is conveniently located on top of the handle.

- Dual pivot action for optimum operation — all shifts actuate linkage in a compression (forward) action
- Precision machined 4130 Chrome Moly shift levers and trans arms assure added strength to prevent breakage
- Lightweight design incorporates aluminum side plates and 4130 Chrome Moly seamless tubular shift rods featuring RH and LH threaded rod ends for easy adjustment without disconnecting linkage
- Neutral gear stops eliminate transmission slider and shift fork drag
- High quality precision "snap action" switches (1 at each gear position) are used for controlling ignition retard, shocks, etc. Complete with wiring harness and weather proof connectors.
- Includes lightweight aircraft fasteners and self locking nuts

Available for Liberty Equalizer 5 speed transmission only from Hurst Specialty Shifter Division Call 216-658-6312

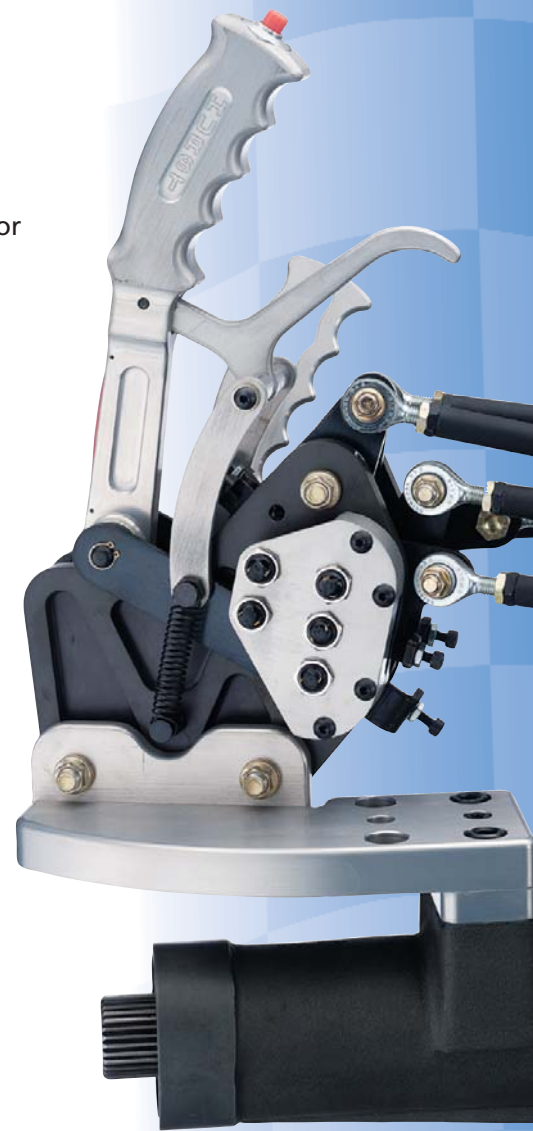
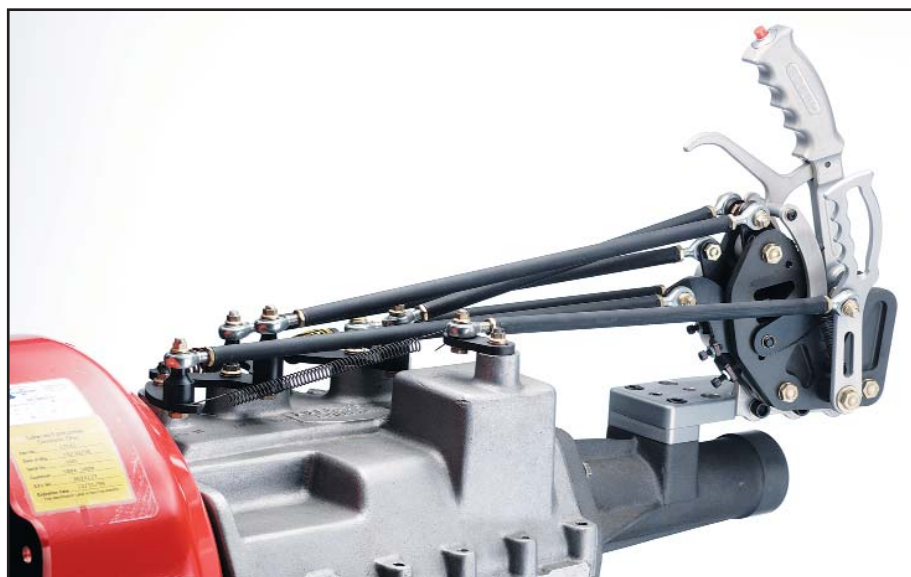



DRAG RACING SHIFTERS

LIGHTNING RODS™ FOR LENCO'S

Pro-Mod, Pro-Stockers and drag racers alike require lightning-quick, accurate shifts. That's why more champions choose to stay with the best — Lightning Rods for Lenco's by Hurst. Available for 4 or 5 speed Lenco transmissions.

- Exclusive Hurst round-to-flat anodized aluminum sticks.
- Quick release mounting pin system.
- Adjustable threaded ball rod end linkage.
- Exclusive F/N/R positive detent gate with chrome-plated squeeze handle.
- Multiple mounting locations.



#384 0012



#384 0022

APPLICATIONS

4-SPEED

Mounting Positions

Shifter & Installation Kit

Forward

384 0006 Straight Handles
384 0016 Bent Handles

Intermediate

384 0002 Straight Handles
384 0012 Bent Handles

Rear

384 0003 Straight Handles
384 0013 Bent Handles

5-SPEED

Intermediate

384 0022

Rear

384 0023

SPECIALTY SHIFTERS

SPEEDWAY SUPER/SHIFTER™

Hurst's Speedway Super/ShifTERS are used in professional circle track racing such as NASCAR, Winston Cup and Busch Grand National Series. The Speedway Super/Shifter utilizes weight saving materials, space-age coatings and provides the ultimate in manual transmission control for endurance and competition.

- Advanced linkage system for proper shifting geometry and space-age coating to reduce drag and decrease wear
- Low mounting proximity helps eliminate tail housing flex
- Heavy-duty internal mechanism components are heat treated for strength and durability to provide additional performance and dependability
- Lubrication management system for ease of maintenance between races
- All grade 8 hardware comes predrilled for safety wire
- Shifter can be tailored to specific driver locations by utilizing the extensive line of bolt-on steel or aluminum sticks
- Installation kit sold separately
Shown with optional shifter stick and knob.
See pages 47-49 for custom stick selection.
See page 55 for trans code information.



#491 0004

APPLICATIONS

SPEEDWAY SUPER/SHIFTER

Transmission	Trans. Code	Shifter Only	Installation Kit
Richmond/BW Super T-10	454	491 0004	373 0024
Muncie	453	491 0004	373 0025

BLUEPRINTED SUPER/SPEEDWAY SHIFTER

This shifter is used by many of the specialty transmission manufacturers who supply the leading 'cup' teams.

- Selector levers are blanchard ground to assure smooth operation
- CNC machined selector pin is assembled with solid bias pins for precise gear changes
- Heat-treated selector pin and levers insure reliability and long life
- Electro-nickel plated to resist corrosion
- Push down reverse lock-out prevents accidental engagement
- Supplied with additional shim plates, special carriage pivot bolt, roll pins and spring washers for serviceability

Part No. 491 0010

This shifter is designed to be used with custom fabricated linkages
Shifter stick and linkage is not included. See pages 47-49 for custom stick selection.



PRO BILLET SUPER/SPEEDWAY SHIFTER

Designed for fast, smooth, positive gear changes, this new and improved 4-speed shifter is an excellent choice for drag or circle track racing and can be specifically tailored to driver comfort by utilizing Hurst's extensive line of bolt-on steel or aluminum sticks.

- BILLET ALUMINUM housing for reduced weight
- CNC-machined components ensure precision tolerances
- Blanchard ground selector levers for smoother positive shifting
- Heat-treated BILLET STEEL selector pin and levers provide strength, reliability and longevity
- Push-down reverse prevents accidental engagement
- Stainless steel fasteners are drilled for safety lock wired.

Part No. 491 0500

This shifter is designed to be used with custom fabricated linkages
Shifter stick and linkage is not included. See pages 47-49 for custom stick selection.





THE ORIGINAL ROLL/CONTROL®

Used primarily in drag racing to provide positive locking action to the front wheels of race cars, reducing the chance of "Rolling the Lights" and producing more effective "Burn Outs" for heating up the tires. Rigorous testing has proved a 1/100,000 of a second release time and vibration tests have seen up to 30 G's applied without mechanical failure. Adaptable to most domestic and import hydraulic brake systems.



- Advanced quality design stainless steel valve assembly for ultimate corrosion resistance
 - Fully enclosed epoxy molded electrical coil for reliability
 - Attractive finned aluminum housing helps dissipate heat
 - Wider lightweight base provides better mounting stability
 - 150 micron screen filtered ports to prevent contamination
 - Field serviceable for cleaning or rebuilding
 - Extra threaded port for separate bleeder or brake line pressure gauge
 - Kit includes solenoid valve, snap-action switch, indicator light, 4-amp fuse, mounting screws and installation instructions
- * 12-volt negative ground systems only.
Part No. 174 5000

CAUTION: The Hurst Roll/Control or Line/Loc® should not be used as an emergency brake, or any application requiring the solenoid to be activated for a long period of time.

ROLL/CONTROL ACCESSORIES



ROLL/CONTROL ADAPTER FITTING KITS

These adapter fitting kits simplify the installation of a Roll/Control or Line/Loc system into late model Camaro, Firebird or Mustang vehicles having metric threaded brake line fittings. Designed to be used with the Hurst Roll/Control Installation Kit #567 1510, these kits consists of special conversion fittings needed for a fast, simple installation.

Make/Model	Year	Part No.
Chevrolet Camaro/Pontiac Firebird	93-02	567 1515
Chevrolet Corvette	85-96	567 1515
Ford Mustang*	83-03	567 1516

*w/o Bosch ABS



ROLL/CONTROL INSTALLATION KIT

The Roll/Control Installation Kit is designed to be used in conjunction with most brake holding devices on American made vehicles. This kit contains brake lines and various brass fittings, connectors, adapters, unions and plugs necessary for an easy installation. Part No. 567 1510

ROLL/CONTROL REPLACEMENT PARTS

Description	Part No.
Roll/Control Rebuild Kit	567 1500
Solenoid only	566 7550

ROLL/CONTROL® ACCESSORIES



COMPETITION SHIFTER KNOB WITH BUILT-IN 12-VOLT SWITCH

Ideal for use with Hurst Roll/Control, trans brake, nitrous oxide systems or other 12 volt accessories. Available in black only.

Thread Size	Part No.
3/8 x 16"	163 0049
7/16 x 20"	163 0050



T-HANDLE WITH BUILT-IN 12-VOLT SWITCH

The ideal command switch for use with Hurst Roll/Control, trans brakes, nitrous oxide systems or other 12 volt accessories, 10-amp capacity, normally open. Now with new snap action button switch for instant activation. Available in brushed aluminum finish only.

Thread Size	Part No.
3/8-16	153 0003
3/8-24	153 0006
7/16-20	153 8510
Mustang 12mm x 1.75	153 4910
Camaro/Firebird 16mm x 1.50	153 4960



SPIRAL CORD WITH HIGH-SPEED SNAP ACTION SWITCH

This precision snap-action switch is ideal for operating Roll/Controls, nitrous systems, trans brakes, etc. The switch is designed to provide instantaneous, smooth operation under the most severe racing conditions.

- Low contact resistance for instantaneous response
- High shock resistance
- Moisture and dust proof for marine and off-road racing
- Epoxy sealed contacts and terminals
- 6' (18 gauge) coil cord for mounting in almost any location
- 10 amp. capacity
- Normally open

Part No. 248 3880



ROLL/CONTROL SWITCH

The Roll/Control Switch incorporates a micro switch for an immediate and accurate release. Includes 2 feet of wire for installation hookup to the Roll/Control, nitrous systems, trans brakes or other 12 volt accessories. 10 amp capacity. Normally open.

Description	Part No.
Replacement Switch for Hurst Roll/Control	248 3875

"SIDEWINDER" SHIFT KNOBS

The "Sidewinder" shift knob is equipped with a side button switch conveniently located for driver hand comfort, which can be used for Roll/Control or nitrous operation.

See page 35 for product details



PISTOL-GRIP SHIFTER HANDLE WITH 12-VOLT SWITCH

CNC machined from solid billet aluminum with a natural finish, the Hurst Pistol-Grip Shifter Handle is designed to provide a firm comfortable natural grip when shifting, allowing less chance of your hand slipping and missing a shift. Equipped with a 12-volt 10 amp capacity normally open snap action switch which can be used for activating a Roll/Control, nitrous or other accessory. One part number fits stock factory shifters in both Mustang w/ 12mm x 1.75 thread and Camaro/Firebird w/ 16mm x 1.50 thread as well as the Hurst Billet/Plus shifters for these applications.

Thread Size	Natural Finish
12mm x 1.75 Mustang	153 6200
16mm x 1.50 Camaro/Firebird	153 6200



SHIFTER KNOBS



CLASSIC SHIFTER KNOBS

- Original Hurst Classic design
- Solid high gloss, high strength plastic
- Engraved inlaid shift pattern
- 1-3/4" diameter, exc as noted below
- Molded-in brass thread insert
- Complete with jam nut



THREAD SIZE	4 SPEED		5 SPEED		6 SPEED	
	White	Black	White	Black	White	Black
3/8-16	163 0003	163 0103	163 0008	163 0108	163 0040	163 0140
3/8-24	163 0002	163 0102	--	--	--	--
7/16-20	163 0022	--	163 0004	163 0104	--	--
9/16-18 Corvette C4	--	--	--	--	*163 0055	*163 0155
9/16-18 Corvette C5	--	--	--	--	*163 0056	*163 0156
12mm x 1.75 Mustang	--	--	*163 0014	*163 0114	*163 0060	*163 0160
16mm x 1.50 Camaro/FB	--	--	--	--	*163 0016	*163 0116

* 2.25" Diameter



REPLACEMENT SHIFTER KNOBS

- Solid high gloss plastic knob with logo
- Molded-in metal thread insert, complete with jam nut

THREAD SIZE	3 SPEED	4 SPEED	5 SPEED	5 SPEED	QUARTER STICK		INDY
	White	White	White	Black	White	Black	Black
3/8-16	163 7624	163 7626	163 0025	163 0125	--	--	163 7200
7/16-20	--	163 0061	163 0061	163 0062	163 1036	163 1037	--



UNIVERSAL SHIFTER KNOBS

Solid high gloss plastic knob with aluminum threaded insert
 Clear top lens design permits use of a photo or vehicle name on the knob
 Includes over 30 vehicle names and shift patterns
 Fits 5/16-18, 7/16-20, 3/8-16, 3/8-24, 1/2-20 and 9/16-18 threaded shift levers

COLOR	PART NO.
White	163 0037
Black	163 0038



#163 2002



#163 2006



#163 2014



CUSTOM SHIFTER KNOBS

- Sporty, custom look
- Available in a variety of styles
- Easily installed
- Fits all 1/4" through 9/16" shifter handle threads

Also a direct replacement for Camaro and Firebird having 16mm x 1.50 threaded factory shifter stick.



#163 2004



#163 2008



#163 2012



#163 2025

STYLE	Short	Tall
BLACK LEATHER	163 2002	163 2004
CARBON FIBER STYLE	163 2006	--
ALUMINUM BILLET	--	163 2008
LEATHER & CARBON FIBER STYLE	--	163 2012
CARBON FIBER STYLE & ALUMINUM	163 2014	--
LEATHER & BRUSHED CHROME	--	163 2025

SHIFTER KNOBS & T-HANDLES



"SIDEWINDER" SHIFT KNOBS

The "Sidewinder" shift knob is equipped with a side button switch conveniently located for driver hand comfort, which can be used for Roll/Control or nitrous operation.

- Features a HD quick release "normally open" 12V switch
- 2-1/4" diameter white knob available with engraved shift pattern for 5-speed Mustang w/12mm x 1.75 thread, 6-speed Camaro/Firebird w/16mm x 1.50 thread and 6-speed Corvette C5 w/9/16-18 thread
- 2" diameter black knob with Hurst logo for all Hurst Quarter Stick shifters with 7/16"-20 thread and Hurst Comp/Plus chrome plated shifter sticks having 3/8"-16 thread



APPLICATIONS	
"SIDEWINDER" SHIFT KNOBS	
12 mm x 1.75 Mustang (white) 5-Speed	163 0051
16mm x 1.50 Camaro/Firebird (white) 6-Speed	163 0052
3/8"-16 thread (black) Hurst logo	163 0069
7/16"-20 thread (black) Hurst logo	163 0070
9/16-18 thread Corvette C5 (white) 6-Speed	163 0076



COMPETITION KNOBS & T-HANDLES WITH SWITCH

- Features a heavy-duty, quick release 12 volt normally open switch w/24" long wire lead
- Ideal for use w/Roll/Control, trans brake, nitrous, etc
- Solid plastic knob w/jam nut
- Quality die cast aluminum T-handles



COMPETITION KNOB	
THREAD SIZE	BLACK
3/8-16	163 0049
7/16-20	163 0050
COMPETITION T-HANDLE	
THREAD SIZE	BRUSHED FINISH
3/8-16	153 0003
3/8-24	153 0006
7/16-20	153 8510
12mm x 1.75	153 4910 (1)
16mm x 1.50	153 4960 (2)

(1) Mustang
(2) Camaro/Firebird



DIRECT FIT T-HANDLES

- Quality die cast aluminum
- Polished or brushed finish
- Bold HURST identification
- Complete w/ jam nut



THREAD SIZE	POLISHED FINISH	BRUSHED FINISH
3/8-16	153 0026	153 4813
3/8-24	153 0027	153 4758
7/16-20	153 8500	153 8501
12mm x 1.75	--	153 4900 (1)
16mm x 1.50	--	153 4950 (2)

(1) Mustang
(2) Camaro/Firebird

HURST EQUIPPED EMBLEM

Based on original HURST blueprints, this HURST EQUIPPED emblem is an authentic reproduction of the one used on the late '60's muscle cars equipped with a factory Hurst shifter. Made of durable ABS plastic with 3M adhesive tape backing for permanent mounting. Nominal size is 1-1/4" high by 5 -1/4" long. Individually packaged.

Part No. 136 1000

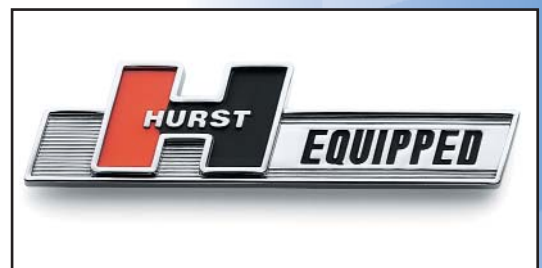



PISTOL GRIP & T-HANDLES



HURST LOGO T-HANDLE

Made of solid die-cast aluminum for strength and durability, this nostalgic T-Handle features a 4-speed shift pattern embossed within the bold Hurst "H" logo.

- Attractive brushed satin finish accented with a black inlaid background for a great look
- Fits all Hurst Comp/Plus chrome plated shifters sticks having 3/8"-16 threads
- Includes jam nut

Style	Part No.
Hurst Logo T-Handle	153 5000



#153 0019

UNIVERSAL HURST T-HANDLES

- Quality die cast aluminum
- Brushed or chrome finish
- Bold HURST identification
- Complete with adapters & jam nut
- SAE fits 1/4-28, 5/16-18, 3/8-16*, 1/2-20
- Metric fits 7mm x 1.00, 8mm x 1.25, 10mm x 1.50, 12mm x 1.50

* SAE 3/8-16 in Chrome Finish only



THREAD SIZE	BRUSHED FINISH	CHROME FINISH
HURST SAE	153 0019	153 0032
HURST Metric	153 0018	153 0033
INDY SAE	153 8430	--



#153 8430

UNIVERSAL INDY T-HANDLES

- Quality die cast aluminum
- Brushed finish
- Bold INDY identification
- Complete with adapters & jam nut
- SAE fits 1/4-28, 5/16-18, 3/8-16, 3/8-24, 1/2-20



PISTOL-GRIP SHIFTER HANDLE

CNC machined from solid billet aluminum, the Hurst Pistol-Grip Shifter Handle is designed to provide a firm comfortable natural grip when shifting, allowing less chance of your hand slipping and missing a shift.

- Available in natural aluminum finish or an attractive black anodized finish with the Hurst name engraved in contrasting letters

Thread Size	Natural Finish	Black Anodized
16mm x 1.50 Camaro/Firebird	153 6000	153 6010
12mm x 1.75 Mustang	153 6000	153 6010
3/8-16 Comp/Plus Shifters	153 6030	153 6130
1/2-20 Dodge Viper	153 6030	153 6130
9/16-18 Corvette	153 6020	153 6120

THREAD SIZE CHART

Hurst Shifters	Stick Thread Size	Hurst Shifters	Stick Thread Size	OEM Shifters	Stick Thread Size
Aluminum sticks	7/16-20	Indy Pick Up Truck	3/8-24	Camaro 6 speed internal rail w/OEM stick	16mm x 1.50
Auto/Stick 1	3/8-16	Indy Qualifier	3/8-16	Firebird 6 speed internal rail w/OEM stick	16mm x 1.50
Auto/Stick 3	3/8-16	Indy SSA	3/8-24	Mustang 5 & 6 speed internal rail w/OEM stick	12mm x 1.75
Billet/Plus w/chrome stick	3/8-16	Pro-Matic, before 1987	1/2-13	Corvette 6-speed 89-04	9/16-18
Billet/Plus w/black stick	Factory OE Thread Size	Pro-Matic 2, since 1987	3/8-16	Viper	1/2-20
Chrome replacement sticks	3/8-16	Quarter/Stick & Q/S 2	7/16-20	B & M Shifters	
Comp/Plus (early)	3/8-24	Quick/Stick	Factory OE Thread Size	Most automatic shifters	1/2-20
Comp/Plus (late), & OEM	3/8-16	Super Shifter 3	3/8-16		
Dual/Gate 2	3/8-16	Vertical Gate, before 1987	1/2-13		
Indy 3 Speed	3/8-24	V-Gate 2, since 1987	3/8-16		
Indy Matic 1	3/8-24	V-Matic, before 1987	1/2-13		
		V-Matic 2, since 1987	3/8-16		

SHIFTER BOOTS



B-1 BOOT & PLATE
Designed for use with round stick shifters.
Complete with chrome ID plate and mounting hardware.

Part No.	Measures
114 7336	4-3/8" x 5-1/2"



B-4 BOOT & PLATE
Our most popular boot is adaptable to most shifter installations. Complete with chrome trim plate and mounting hardware.

Part No.	Measures
114 4580	3-1/2" x 4-1/2"



INDY QUALIFIER BOOT & PLATE
Designed for use with Hurst/Indy Qualifier Shifter.
Complete with chrome trim plate and mounting hardware.

Part No.	Measures
114 8435	2-1/2" x 3-1/2"



INDY BOOT & PLATE
A popular economy boot. Complete with chrome trim plate and mounting hardware.

Part No.	Measures
114 8429	3-1/2" x 4-1/2"



SUPER BOOT & PLATE
Designed for large hole shifter installations.
Complete with chrome ID plate and mounting hardware.

Part No.	Measures
114 7494	7-3/4" x 8-3/4"



V-GATE 2 BOOT & PLATE
Specially designed for use with the V-Gate 2 or Mr. Gasket Vertical Gate 4- & 5-speed shifter which utilizes a trigger operated main stick. Complete with chrome trim plate and mounting hardware.

Part No.	Measures
114 1653	8-1/4" x 12-1/8"



SUPER/SHIFTER 3 BOOT & PLATE
Specially designed for use with Super/Shifter 3 utilizing separate reverse Loc/Out lever. Complete with chrome trim plate and mounting hardware.

Part No.	Measures
114 0010	7-3/4" x 8-3/4"



REPLACEMENT BOOT
For use as replacement for all die cast aluminum internal rail shifters.

Part No.	Measures
114 0024	5" x 3-3/4"



REPLACEMENT BOOT
Used on most Billet/Plus shifters.

Part No.	Measures
114 5001	3" I.D. Round Base



HOT SHIFT® 2 & 3

HIGH PERFORMANCE SHIFT MODIFYING KITS

Hot Shift 2 and Hot Shift 3 are the best way to modify the shift patterns of automatic transmissions for optimum performance. Along with the legendary Hurst name, automatic transmission owners can now enjoy quicker, more precise shifts, lower operating temperatures, and increased overall transmission efficiency.



Hot Shift 2

- Heavy-Duty: provides a firm shift without any harshness.
- Street-Strip: for tire chirping shifts. Ideal for the hi-performance enthusiast on a budget.

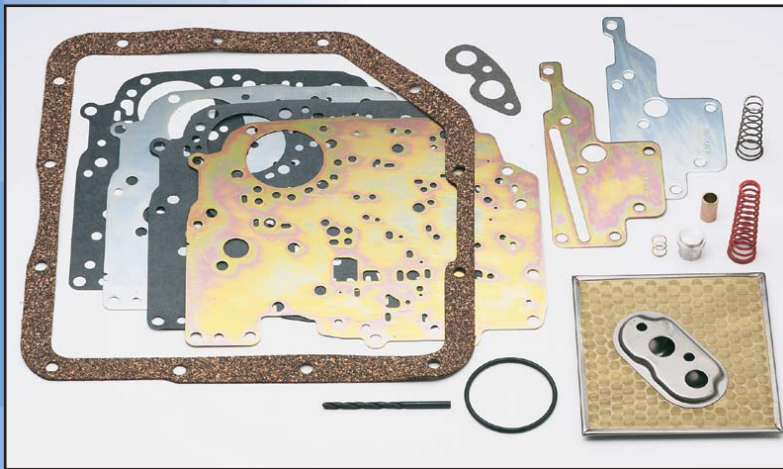

Hot Shift 3

- Heavy-Duty: firm shifts, ideal for towing, fleet use, RV, or everyday street use
- Street-Strip: provides a much harder instantaneous shift, while retaining the automatic shifting capabilities.
- Race Only: for all out racing only! Extremely hard shifts. Not suitable for street use.

Note: To be used on vehicles with NON-Lock up Torque Converters.

A P P L I C A T I O N S

Transmission	Year	HOT SHIFT 2		HOT SHIFT 3	
		Part No.	Part No.	Part No.	Part No.
GM TH 350	68-81	285 8601	285 8611		
GM TH 400	65-87	285 8602	285 8612		
Ford C-6	67-91	285 8630	285 8640		
Mopar A727/904	71-77	285 8660			—

ACCESSORIES



HOT SHIFT® ATF FLUID

Formulated to improve the performance of all automatic transmissions, Hurst Hot Shift ATF is one of the most advanced custom blended fluids available today. This fluid is so effective in reducing friction that your transmission will actually run cooler!

- Exclusive formula combines friction modifiers, extreme pressure additives and anti-foaming agents to increase clutch plate lock-up, resulting in quicker, firmer and more positive shifts.
- Ideal for use in passenger cars, high performance street and race cars, light trucks, off-road and recreational vehicles.

Hot Shift *High Performance* ATF meets requirements of DEXRON II, (1-Quart) **Part No. 180 1000**

Hot Shift *Synthetic Blend* ATF provides better oxidation stability, greater film strength and increased cold flow characteristics compared to conventional petroleum based transmission fluids. Mixes well with and meet requirements of Mercon and DEXRON III. (1-Quart) **Part No. 180 2000**

NOTE: Maximum benefits and protection are obtained when transmission and converter are fully drained and refilled exclusively with Hot Shift *High Performance* ATF or Hot Shift *Synthetic Blend* ATF.



AUTOMATIC TRANSMISSION SWAP KITS FOR CAMARO, FIREBIRD

Installing a Turbo-Hydro 350 or 400 in your '82-'91 Camaro or Firebird has just been made easier with a new transmission swap kit from Hurst Performance. Designed to assist in replacing the stock automatic or manual transmission in V8 applications, these kits eliminate having to fabricate custom brackets and adapters, allowing for a relatively hassle-free, bolt-in installation. Note: Though no additional fabrication is required to make the swap, the driveshaft must be shortened to accommodate the TH 400 transmission and a TH 400 front yoke must be used. Each kit is complete with a new torque arm bracket, two transmission arms, cable brackets, spacers and related hardware. The TH 400 kit includes a new transmission crossmember assembly while the TH 350 kit utilizes the stock OEM crossmember.



'82-'91 CAMARO/FIREBIRD	
Transmission	Part No.
TH 350	550 0001
TH 400	550 0002

AUTOMATIC TRANSMISSION DRAIN PLUG

This universal oil drain plug can be used on most automatic transmission oil pans. It makes oil changes possible without dropping the oil pan. Requires a 1/2" diameter hole for installation. Complete with instructions and brass plug for convenient sealing. **Part No. 285 4470**





SERVICE PARTS

AUTO/STICK 3, Automatic Shifter - Cable Operated

Part Number	Shifter	Cable Bracket	Neutral Switch	Cable	Console	Console Plate	Pattern Label	Tee Handle	Cable Bracket	Cable Bracket GM	Cable Bracket Chrys.	Trans Arm	Inst. Sheet	Bagged Hdwr.
383 0012	383 0005	117 0092	248 0003	500 0025	129 0003	195 0122	241 0002	153 4813	117 5711	117 0094	117 0037	105 0080	159 0155	154 0128
							Std. Pattern				(C-4)			
							241 0003				117 0038	105 0082		
							Rev. Pattern				(C-6)			
												105 0081		

DUAL/GATE 2 CUSTOM FIT FOR CAMARO, FIREBIRD

Part Number	Front Bracket	Rear Bracket	Lens Shift Indicator	Escutcheon	Knob	Bagged Hdwr.	Inst. Sheet
292 0000	117 4768	117 4773		140 0009	163 7200	154 8390	159 1034

DUAL/GATE 2, Automatic Shifter - Cable Operated

Part Number	Shifter Only	Front Bracket	Rear Bracket	Trans Arm	Lamp Housing	Bulb Socket	Cable	Pattern indicator	Console	Console Plate	Cable Bracket	Bagged Hdwr.
292 0006	292 0003	117 0144	117 0145	105 0080	157 0126	166 0002	500 0025	241 0004	129 0009	195 0140	117 5711	154 0136
											117 4778	154 0137
				105 0082						195 0140		154 0136
292 0007	292 0004	117 0144	117 0145	105 0081	157 0126	166 0002	500 0025	241 0004	129 0009	117 0037	117 0094	154 0137
				105 0081						117 0038		

INDY MATIC

Part Number	Shifter Assy.	Arm Chevrolet Mercomatic	Arm Fordomatic Cruisomatic	Arm Fordomatic Oldsmobile	Arm Pontiac Oldsmobile	Arm Pontiac	Rods	Inst. Sheet
506 0001	506 0003	105 0007	105 0008	105 0009	105 0011	105 0012 213 0012 - bent	213 0011 - straight	159 0022

INDY 3-SPEED SHIFTER AND INSTALLATION KIT

Part Number	Shifter Assy.	Mounting Bracket	Stiffener Brace	Arm 1 & Rev.	Arm 2 & 3	Rod 1 & Rev.	Rod 2 & 3	Bagged Hardware	Bagged Bagged	Inst. Sheet
501 0002	501 0004	117 0212	116 0001	105 0005	105 0004	213 0002	213 0003	154 0110	154 0002	159 0876
										159 0129
501 0016	501 0017	117 0212	116 0001	105 0005	105 0005	213 0190	213 0214 213 0192	154 0110	154 0176	159 0129
							213 0209			159 1001
501 0018		117 0212	116 0001	105 0005	105 0005	213 0002	213 0190	154 0110	154 0189	159 0129
										159 1021

INDY FOUR-SPEED SHIFTER AND INSTALLATION KIT

Part Number	Shifter w/o Stick	Stick	Mounting Plate	Arm 1 & 2	Arm 3 & 4	Arm Rev.	Rod 1 & 2	Rod 3 & 4	Rod Rev.	Bagged Hardware	Inst. Sheet
503 0030	503 0024	238 0077	195 0037	105 2140 105 7058	105 7075 105 2141 105 7060	105 0055 105 0052	213 7803	213 0079	213 7819 213 1699	154 7813	159 0125
503 0031	503 0024	238 0077	195 8382	105 8383	105 2141	105 7647	213 8377	213 8378	213 8379	154 8374	159 0126
503 0032	503 0024	238 0077	195 2298	105 4829	105 3894	105 3832	213 1588	213 8003	213 8037	154 8006	159 0127
			117 0084								
503 0033	503 0024	238 0077	116 0010	105 4293	105 4294	105 0016	213 0037	213 0039	213 0038	154 0116	159 0128

SERVICE PARTS



PRO-MATIC 2 & V-MATIC 2, Automatic Shifter - Cable Operated

Part Number	Trans Model	Cable Bracket	Console Black	Console Cover Chrome	Boot Plate Chrome	Indicator Lens Cover	Neutral-Safety Back-Up Switch	Rubber Boot	Shifter Cable	Trans Arm	Trigger Polished
383 8500	TH 250 & 350	117 8562				241 8552				105 8561	
	TH 400	117 8560				(Forward Body)				105 8561	
	C 6	117 8557	129 8554	195 8551	--	241 8567	248 0021	114 8550	500 8555	105 8559	--
	C 4	117 8558				(Reverse Body)				105 8559	
383 8504	A 727 & 904	117 8563								105 8564	
	TH 700 R4	117 4778	129 8554	195 8551	--	169 0005	248 0021	114 8550	500 8555	105 8567	--
383 8505	TH 200 4R	117 4778								105 8572	--
	Powerglide	117 8565	129 8554	195 8551	--	241 8553	248 0021	114 8550	500 8555	105 8566	--
383 8510	TH 250 & 350	117 8562								105 8561	
	TH 400	117 8560								105 8561	
	C 6	117 8557	129 8554	195 8551	--	241 8552	248 0021	114 8550	500 8555	105 8559	--
	C 4	117 8558								105 8559	
383 8511	A 727 & 904	117 8563								105 8564	
	TH 700 R4	117 4778	129 8554	195 8551	--	169 0005	248 0021	114 8550	500 8555	105 8567	--
383 8515	TH 200 4R	117 4778								105 8572	--
	TH 250 & 350	117 8562	--	--	195 8574	241 8570	248 0021	114 8572	500 8555	105 8561	307 8576
383 8520	TH 400	117 8560				(Forward Body)				105 8561	
	TH 250 & 350	117 8562								105 8561	
	TH 400	117 8560								105 8561	
	C 6	117 8557	129 8554	--	195 8574	241 8570	248 0021	114 8572	500 8555	105 8559	307 8576
383 8521	C 4	117 8558								105 8559	
	A 727 & 904	117 8563								105 8564	
383 8522	TH 700 R4	117 4778	129 8554	--	195 8574	169 0006	248 0021	114 8572	500 8555	105 8567	307 8576
	TH 200 4R	117 4778								105 8572	307 8576
383 8525	Powerglide	117 8565	--	--	195 8574	241 8571	248 0021	114 8572	500 8555	105 8566	307 8576
383 8530	TH 250 & 350	117 8562	--	--	195 8574	241 8570	248 0021	114 8572	500 8555	105 8561	307 8576
	TH 400	117 8560								105 8561	307 8576
383 8531	TH 250 & 350	117 8562	--	--	195 8574	241 8570	248 0021	114 8572	500 8555	105 8561	307 8576
	TH 400	117 8560								105 8561	307 8576

REPLACEMENT SHIFTER SPRINGS

Restore precise shifter action by replacing the weak or damaged springs in the Pro-Matic, V-Matic or Billet/Plus shifters.

The Pro-Matic and V-Matic kit includes 1 of each centering, ratchet and position springs, part #230 8500, see page 46

The Billet/Plus kit includes two of each inner and outer bias springs, part #230 5000, see page 46

QUARTER STICK, Automatic Shifter - Cable Operated

Part Number	Trans Model	Shifter Only	Cable Bracket	Trans Arm	Cable	Console	Inst. Sheet
316 0001	Powerglide		117 0095	105 0084			
	TH 200, 350, 375, 400	316 0003	117 4778	105 0080	500 0025	130 0041	159 0999
316 0006	TH 200, 350, 375, 400	316 0008	117 4778	105 0080	500 0025	130 0041	159 1004
316 0009	C-6		117 0038	105 0081			
	C-4	316 0011	117 0037	105 0081	500 0025	130 0041	159 1004
	A727-904		117 0094	105 0082			
316 0014	A727-904		117 0094	105 0082			
	C-4	316 0017	117 0037	105 0081	500 0025	130 0041	159 1018
	C-6		117 0038	105 0081			
316 0016	TH 250, 350, 375, 400	316 0018	117 4778				
			117 0199	105 0059	500 0025	130 0041	159 1009
316 0020	Powerglide		117 0098	105 7000			
	TH 250, 350, 375, 400	316 0021	117 0099	105 0098	500 0025	130 0056	159 0998
316 0025	TH 250, 350, 375, 400		117 0099	105 0098			
	Powerglide	316 0026	117 0098	105 7000	500 0025	130 0056	159 0998
316 0030	TH 700 R4	316 0088	117 4778	105 0080	500 0025	140 0020	159 1032
316 0082	TH 700 R4	316 0019	117 4778	105 0080	500 0029		159 1010
316 0083	TH 700 R4	316 0087	117 4778		500 0029		159 1033



SERVICE PARTS

COMPETITION/PLUS, 4-Speed Installation Kits

Installation Kit	Mounting Plate	Arm 1 & 2	Arm 3 & 4	Arm Reverse	Rod 1 & 2	Rod 3 & 4	Rod Reverse	Bagged Hardware	Bagged Hardware	Instruction Sheet
373 0017	195 0125	105 4293	105 4294	105 4295	213 0136	213 0137	213 0135	154 0131	-	159 0168
373 0021	195 0199(1)	105 0043	105 0044	105 2489	213 0163	213 0164	213 0165	154 0174	-	159 0997
373 0022	195 0199(1)	105 4293	105 4864	105 4295	213 0193	213 0194	213 0195	154 0178	-	159 1003
373 3157	195 7773	105 2140	105 2141	105 1670	213 2144	213 2145	213 2146	154 3151	154 0073(21)	159 0181
373 3162	195 8008	105 2440	105 2441	105 2445	213 2144	213 2145	213 2439	154 4097	154 0071(21)	159 0269
373 3163	195 7773	105 2440	105 2441	105 2442	213 2438	213 2139	213 3404	154 3151	154 0071(21)	159 0274
373 3164	195 2482	105 2140	105 2488	105 2489	213 2486	213 2485	213 2487	154 3152	154 0071(21)	159 0279
373 3165	195 2722	105 2723	105 2724	105 2725	213 2726	213 2727	213 2728	154 3153	154 0071(21)	159 0307
373 3166	195 2816	105 2140	105 2141	105 1670	213 2814	213 2815	213 2444	154 3154	154 0071(21)	159 0391
373 3167	195 2816	105 2723	105 2724	105 3698	213 3691	213 2774	213 3695	154 3154	154 0071(21)	159 0381
373 3668	195 3176	105 3665	105 3666	105 3667	213 2758	213 3172	213 2137	154 3183	-	159 0375
373 4089	195 6348(1)	105 3894	105 3831 105 3667	105 2445	213 4164	213 3830	213 3189	154 4088	154 0071(21)	159 0412
373 4297	195 4204	105 4293	105 4294	105 4295	213 4187	213 4188	213 4335	154 4242	154 0071(21)	159 0425
373 4354	195 4345	105 4346	105 2441	105 4347	213 4348	213 1588	213 2487	154 4353	154 0071(21)	159 1042
373 4529	117 5284(3)	105 5286	105 5287	105 2445	213 5307	213 2145	213 3691	154 5289	154 0071(21)	159 0464
373 4531	117 5284(3)	105 4293	105 4294	105 4295	213 5298	213 5299	213 5308	154 5289	154 0071(21)	159 0463
373 4648	195 8008	105 2440	105 2441	105 2445	213 2144	213 2145	213 2146	154 4097	154 0071(21)	159 0598
373 4734	195 7773	105 2140	105 2141	105 2142	213 2138	213 2139	213 3404	154 3151	154 0071(21)	159 0181
373 5587	117 6889 195 6834	105 2723	105 2108	105 2725	213 1720	213 2774	213 3207	154 4197	-	159 0344
373 6819	195 0165(1)	105 5286	105 2656	105 2442	213 2920	213 4769	213 6818	154 0163 154 6821	154 0071(21)	159 0676 159 0981
373 7131	117 5284(3)	105 7129	105 7130	105 7128	213 5307	213 2145	213 3691	154 5289	154 0071(21)	159 0765
373 7437	195 0164(1)	105 7129	105 7130	105 7128	213 5307	213 2145	213 3691	154 0162 154 6821	154 0071(21)	159 0796
373 7637	195 3176	105 2723	105 2108	105 7647	213 1720	213 2774	213 3207	154 3183	-	159 0802
373 7638	195 4120	105 2723	105 2108	105 7646	213 4146	213 2774	213 4147	154 4197	-	159 0801
373 7717	195 7719(4)	105 2723	105 2108	105 7647	213 1720	213 2774	213 3207	154 3183	-	159 0802
373 7823	195 0165(1)	105 7129	105 4294	105 7825	213 2920	213 4769	213 6818	154 6821	154 0071(21)	159 0812
373 7834	195 7773	105 7058	105 7060	105 7059	213 2438	213 2139	213 3404	154 3151	154 0071(21)	159 0813
373 7897	195 0163	105 7129	105 7130	105 7899	213 3646	213 2139	213 2137	154 6821	154 0071(21)	159 0822
373 7919	117 4208(6)	105 4293	105 4294	105 7923	213 4187	213 4188	213 4335	154 7922	-	159 0823

1. Spacer plate195 4319
 3. U-Bolt265 5293
 4. Bracket117 6889

5. Stick Spacer228 8397
 6. U-Bolt265 4388
 7. Back-drive rod213 0030
 21. Stick Bolts and Stop Bolts154 0071

SERVICE PARTS



COMPETITION/PLUS, 4-Speed Installation Kits (Continued)

Installation Kit	Mounting Plate	Arm 1 & 2	Arm 3 & 4	Arm Reverse	Rod 1 & 2	Rod 3 & 4	Rod Reverse	Bagged Hardware	Bagged Hardware	Instruction Sheet
373 8604	117 4208(6)	105 4293	105 4294	105 4295	213 4187	213 4188	213 4335	154 7922	-	159 0061
373 8605	195 0163(1)	105 7129	105 7130	105 7899	213 3646	213 2139	213 2137	154 6821	-	159 0070
373 8607(7)	195 8008	105 4293	105 4294	105 0016	213 5298	213 5299	213 5307	154 4097	154 0071(21)	159 0075
373 8608	195 0165(1)	105 7129	105 4294	105 7825	213 2920	213 4769	213 6818	154 6821	-	159 0981
373 8609	195 0065(1)	105 2440	105 2441	105 0028	213 4646	213 2139	213 6818	154 0061	154 0071(21)	159 0083
373 8611	195 8008	105 7058	105 7060	105 7061	213 0046	213 2145	213 2146 213 4147	154 0070	154 0074(21)	159 0089
373 8613	195 2298	105 2141	105 0049	105 3667	213 2815	213 2145	213 0078	154 8006	-	159 0120
373 8615	195 8382	105 8383	105 2141	105 7647	213 8377	213 8378	213 8379	154 8374	-	159 0135
373 8616	195 0037	105 2140 105 7058	105 2141 105 7060	105 0052 105 0055 105 7075	213 7803	213 0079	213 1699 213 7819	154 0081 154 7813	-	159 0136
373 8617	195 2298	105 4829	105 3894	105 3832	213 1588	213 8003	213 8037	154 8006	-	159 0137
373 8618	117 0084 116 0010	105 4293	105 4294	105 0016	213 0037	213 0039	213 0038	154 0116	-	159 0139
373 8620	117 0158	105 3894	105 0070	105 0073	213 0152	213 1588	213 0153	154 0150	-	159 0938
373 8621	195 0148	105 2440	105 2441	105 2445	213 0046	213 2145	213 0151	154 4097	-	159 0925

- | | | | |
|-----------------------|----------|--------------------------------------|----------|
| 1. Spacer plate | 195 4319 | 5. Stick Spacer | 228 8397 |
| 3. U-Bolt | 265 5293 | 6. U-Bolt | 265 4388 |
| 4. Bracket | 117 6889 | 7. Back-drive rod | 213 0030 |
| | | 21. Stick Bolts and Stop Bolts | 154 0071 |

COMPETITION/PLUS, Shifter & Stick Assemblies

Shifter	Shifter w/o Stick	Stick only	Shifter	Shifter w/o Stick	Stick only
391 0001	391 5401	538 4331	391 3180	391 0014*	-
391 0002	391 5403	538 4331	391 3780	391 0011*	-
391 0024	391 8394	238 0085	391 4339	391 4340	538 4106
391 0027	391 5401	538 0060	391 6789	391 4076	538 4078
391 0028	391 5405	238 0131	391 6822	391 6817	538 6836
391 0029	391 0040	538 0201	391 6848	391 5401	538 6836
391 0030	391 0038	538 0197	391 7307	391 5401	538 7236
391 0031	391 0041	538 0202	391 7308	391 5403	538 7236
391 0032	391 0037	538 0196	391 7438	391 4340	538 7436
391 0033	391 0040	538 0090	391 7535	391 5401	538 7238
391 0035	391 0051	538 8550	391 7930	391 8394	538 7236
391 0036	391 0051	538 8550	391 7960	391 5405	538 7238
391 0060	391 0056	538 8570	391 7992	391 5403	538 7991
391 0061	391 0057	538 8571	391 8014	391 8010	538 8009
391 0070	391 0069	538 0197	391 8789	391 8787	538 6836
391 0110	391 0119	538 0290	391 8791	391 7879	538 8009
391 0120	391 0119	538 0291	391 8792	391 8793	538 6836
			391 8794	391 5401	538 8009

* Includes welded stick, not available separately.



SERVICE PARTS

LIGHTNING RODS FOR LENCOS

Description	Part No.	Part No.	Part No.	Part No.	Part No.	Part No.
	384 0012	384 0002	384 0013	384 0003	384 0016	384 0006
Shifter Only	384 0014	384 0004	384 0015	384 0005	384 0017	384 0007
Installation Kit	373 0018	373 0018	373 0019	373 0019	373 0020	373 0020
Bagged Hdwr.	154 0171	154 0171	154 0171	154 0171	154 0171	154 0171
					154 0173	154 0173
Arms	1-105 0090	1-105 0090	3-105 0089	3-105 0089	1-105 0090	1-105 0090
	2-105 0089	2-105 0089			2-105 0089	2-105 0089
Arm Reverse	105 0074	105 0074	105 0074	105 0074	105 0074	105 0074
Rods	17" - 213 0173	17" - 213 0173	22" - 213 0173	22" - 213 0173	10" - 213 0189	10" - 213 0189
	9" - 213 0175	9" - 213 0175	14" - 213 0169	14" - 213 0169	8.5" - 213 0177	8.5" - 213 0177
	2" - 357 0028	2" - 357 0028	6" - 213 0171	6" - 213 0171	3.75" - 357 0029	3.75" - 357 0029
Reverse Rod	213 0162	213 0162	213 0161	213 0161	213 0089	213 0089
Mounting Plate	195 0167	195 0167	195 0168	195 0168	--	--
Clamp Assembly	126 0015	126 0015	126 0015	126 0015	126 0015	126 0015
Detent Disc	134 0004	134 0004	134 0003	134 0003	134 0003	134 0003
Link	171 0016	171 0016	171 0016	171 0016	171 0016	171 0016
Pin 1/4"	189 0071	189 0071	189 0071	189 0071	189 0071	189 0071
Pin 5/16"	189 0070	189 0070	189 0070	189 0070	189 0070	189 0070
Knob	163 0034	163 0034	163 0034	163 0034	163 0034	163 0034
Instruction Sheet	159 0996	159 0996	159 0996	159 0996	159 0996	159 0996

MASTERSHIFT, 3-Speed Installation Kits

Installation Kit	Mounting Bracket	Stiffener Brace	Arm L-R	Arm 2 & 3	Rod L & R	Rod 2 & 3	Bagged Hardware	Bagged Hardware	Inst. Sheet	Misc. - See Footnotes
367 0006	117 0044 117 0045	116 0007	105 7135	105 7130	213 0024	213 0025	154 0053	154 0071(21)	159 0063	16
367 0012	117 0061 117 0062	116 0017	105 0035 105 0054	105 0036 105 0056	213 4093	213 0058	154 0076	154 0071(21)	159 0100	10
367 0013	117 0007	116 0004 117 4777	105 4746	105 4747	213 4742 213 0062	213 4741 213 0063	154 0025	154 0071(21)	159 0101	10-16
367 0014	117 0071	116 0021	105 1573	105 2108	213 2001	213 0066	154 0095	-	159 0110	10
367 0023	117 0062 117 0061	116 0016	105 0031 105 0057	105 0032 105 0058	213 0058	213 3601	154 0076	-	159 0156	-
367 0025	117 0097 117 0096	116 0025	105 4864	105 4865	213 0080	213 1588	154 0130	-	159 0166	10
367 0027	117 0151	116 2319	105 7656	105 2320	213 2321 213 1562	213 2322 213 0147	154 0013	-	159 0927	10
367 3111	117 7154	116 7153	105 1526	105 1550 105 1657	213 2007	213 2008	154 0016	154 0071(21)	159 0020	10-16
367 3112	117 8227	116 1734	105 1526	105 1550	213 1735 105 1657	213 1736	154 0009	154 0071 (21)	159 0003	10-16
367 7143	117 8228	-	105 7144	105 4864	213 4209	213 4210	154 0010	154 0071(21)	159 0014	10-6-16
367 7640	195 3176	-	105 7645	105 1779	213 2758	213 3172	154 0024	154 0071(21)	159 0017	10-16

MASTERSHIFT, Shifter & Stick Assemblies

Shifter	Shifter w/o Stick	Stick only	Shifter	Shifter w/o Stick	Stick only
366 0010	366 0001	538 0060	366 6809	366 0001	538 4331
366 0014	366 0001	238 0085	366 6901	366 0001	538 6900
366 3179	366 0008	-	366 7271	366 0001	538 7236

SERVICE PARTS



RICHMOND 5-SPEED SHIFTER AND INSTALLATION KIT

Part Number	Shifter w/o stick	Stick	Shifter Plate	Arm 1 & 2	Arm 3 & 4	Arm 5th Rev.	Rod 1 & 2	Rod 3 & 4	Rod 5th Rev.	Bagged Hdwr.	Instruction Sheet
407 0009	407 0010	538 1000	195 0133	105 0043	105 0043	105 0043	213 0143	213 0144	213 0145	154 0109	159 0177
407 0015	407 0010	538 7238	195 0133	105 0043	105 0043	105 0043	213 0143	213 0144	213 0145	154 0109	159 0177

SUPER/SHIFTER 3 & SPEEDWAY SUPER/SHIFTER, 4-Speed Installation Kits

Installation Kit	Mounting Plate	Arm 1 & 2	Arm 3 & 4	Arm Reverse	Rod 1 & 2	Rod 3 & 4	Rod Reverse	Bagged Hardware	Instruction Sheet
373 0006	195 0037	105 0023	105 0024	105 0055 105 7075	213 0071	213 0072	213 0084	154 0117	159 0141
373 0007	195 0037	105 7058	105 7060	105 7075	213 0071	213 0072	213 0084	154 0117	159 0141
373 0011	117 4819	105 4828	105 4829	105 0053	213 0106	213 0100	213 0096	154 0121	159 0144
373 0014	195 8382	105 8383	105 2141	105 7647	213 0110	213 0105	213 0101	154 0119	159 0147
373 0024	195 0222	105 0085	105 0086	105 0087	213 0197	213 0198	213 0200	154 0182	159 1008
373 0025	195 0222	105 0094	105 0095	105 0093	213 0205	213 0198	213 0206	154 0182	159 1008

SUPER/SHIFTER 3 & SPEEDWAY SUPER/SHIFTER, Shifter & Stick Assemblies

	Shifter	Shifter w/o Stick	Stick Only
Super/Shifter 3	491 0001	491 0002	538 7238
Speedway Super/Shifter	491 0004	391 0039	-

V-GATE 2, Installation Kit

Installation Kit	Mounting Plate	Arm 1 & 2	Arm 3 & 4	Arm Reverse	Rod 1 & 2	Rod 3 & 4	Rod Reverse	Bagged Hdwr.	Inst. Sht.
373 8164	195 9045	105 8026	105 8025	105 8016	213 6102	213 6104	213 6134	154 8164	159 8164
373 8165	195 9037	105 8030	105 8031	105 8006	213 6162	213 6104	213 6135	154 8165	159 8165
373 8171	195 9026	105 8038	105 8032	105 8000	213 6109	213 6110	213 6126	154 8171	159 8171
373 8172	195 9026	105 8038	105 8032	105 8039	213 6111	213 6112	213 6113	154 8172	159 8172
373 8174	195 9026	105 8039	105 8032	105 8040	213 6117	213 6106	213 6127	154 8174	159 8174
373 8175	195 9044	105 8038	105 8032	105 8000	213 6118	213 6110	213 6126	154 8175	159 8175
373 8180	195 9038	105 8028	105 8029	105 8006	213 6100	213 6103	213 6123	154 8180	159 8180
373 8182	195 9034	105 8028	105 8029	105 8006	213 6102	213 6104	213 6125	154 8182	159 8182
373 8188	195 9037	105 8030	105 8031	105 8031	213 6163	213 6164	213 6106	154 8188	159 8188
373 8190	195 9037	105 8039 (T-10) 105 8026 ('69 & up Mun)	105 8032(T-10) 105 8025 ('69 & up Mun)	105 8006(T10) 105 8027 ('69 & up Mun)	213 6102	213 6104	213 6124 213 6120	154 8190	159 8190
373 8193	195 8657	105 8573 (Pre '69 Mun)	105 8574 (Pre '69 Mun)	105 8575 (Pre '69 Mun)	213 8697	213 8698	213 2322	154 8193	159 8193

ROLL CONTROL

Part Number	Switch Assy.	Indicator Light w/o Bulb	Solenoid Valve 12V	Instructions	Rebuild Kit No.
174 5000	248 3875	97001835	566 7550	159 0394	567 1500



SERVICE PARTS

SHIFTER CABLES

Replacement shifter cables are available for all Hurst automatic shifters. Additionally, several lengths of cables are available for the Quarter Stick and Pistol Grip shifters. These premium quality cables feature a solid 303 Stainless Steel inner wire core encased within a nylon liner wrapped with helical lay wires and swaged ends for superior strength. The core is lubricated with Teflon prior to assembly and then sealed in a heavy plastic outer casing for a lifetime of durability and smooth operation.



#500 0029

Part No.	Cable Length
500 0023	3 ft. Adjustable Single Eyelet
500 0024	4 ft. Adjustable Single Eyelet
500 0025*	5 ft. Adjustable Single Eyelet
500 0028	8 ft. Adjustable Single Eyelet
500 0020	11 ft. Adjustable Single Eyelet
500 0029**	5 ft. Adjustable Double Eyelet
500 8555***	5 ft. Adjustable Single Eyelet
127 5702	Cable Clip Only

Standard Replacement Cables



Auto Stick 3, Pistol Grip, Q-Stick/Q-Stick 2, Lightning Rods, Pick-up Truck Auto stick, Dual Gate 2, Van Auto Stick

Part No. 500 0025

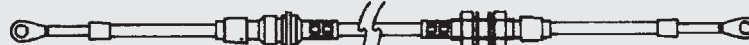

Q-Stick (Late model Camaro, Monte Carlo)

Part No. 500 0029



Pro Matic 2, V-Matic 2

Part No. 500 8555

IMPORTANT: Make sure the cable is not kinked, bent in too tight of a radius, touching the exhaust manifold or dragging the ground. If this occurs, make the adjustment to eliminate the problem.

* Standard cable for most Quarter Stick shifters.

** Standard cable for Quarter Stick Shifters No.s 316 0082, 316 0083

*** Standard cable for the Pro Matic 2 and V-Matic 2. Also used as a replacement for B&M cable No. 80605.



#230 8500

#230 5000

REPLACEMENT SHIFTER SPRINGS

Restore precise shifter action by replacing the weak or damaged springs in the Pro-Matic, V-Matic or Billet/Plus shifters. The Pro-Matic and V-Matic kit includes 1 of each centering, ratchet and position springs.

Part No. 230 8500

The Billet/Plus kit includes two of each inner and outer bias springs.

Part No. 230 5000



HURST PIT PACKS

Available in either steel or nylon. Steel bushings are designed to take the punishment of racing applications and provide for longer service. Nylon bushings are designed for street applications and eliminate most of the stick vibrations. These pit packs can be used on the Master Shift 3-Speed, Competition Plus 4-Speed and the V-Gate 2. Kit includes either 7 steel or nylon bushings and spring clips.

Part No.	Application	Description
332 0001	3-, 4-, & 5-speed manuals	Nylon bushings
332 7302	3-, 4-, & 5-speed manuals	Steel bushings
154 3398	3-, 4-, & 5-speed manuals	Steel bushings (Bulk 100 pcs.)
332 1657	V-Gate 2 only	Steel bushings

* Pit Packs should be replaced every 2-3 years for optimum performance.



SUPER/SHIFTER 3 PIT PACK

This pit pack is designed specifically for the Super/Shifter 3. Kit includes 6 each of steel bushings, locking tabs and locknuts for use on "bolt-on" linkage rods. (Also fits Ram Rod shifters). Part No. 332 0002

ROD BUTTONS/OE REPLACEMENTS

Part No.	Application	Description
119 8060	Competition/Plus Rod Button	2 per pack
119 0002	Super/Shifter 3 Rod Button	1 per pack
119 8057PO	Indy 3-speed Shifters Rod Button	1 per pack
280 0001	OE Rubber Grommet - Ford	1 per pack
126 3705	Stick Clamp/OE Shifters	1 per pack
161 3706	Stick Isolator/OE Shifters	1 per pack

SHIFTER STICKS



LIGHT WEIGHT ALUMINUM STICKS

Hurst aluminum shifter sticks are more resilient than steel in competition use, and are one-third lighter. 2024 aluminum heat treated to T-6. Ultimate tensile strength 68,000 psi. All aluminum sticks incorporate a 7/16 - 20 thread size and 7/8" center to center bolt spacing with 3/8" ID hole size.

NATURAL ALUMINUM FINISH

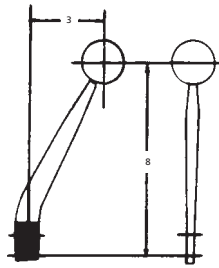

#538 0178
Used on shifters
366 0005, 391 8790

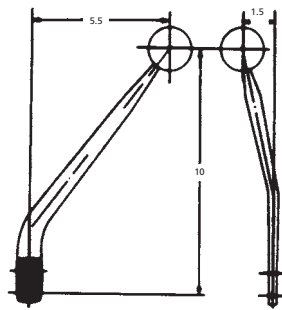

#538 0179
Used on shifters 391 4339, 366 4550

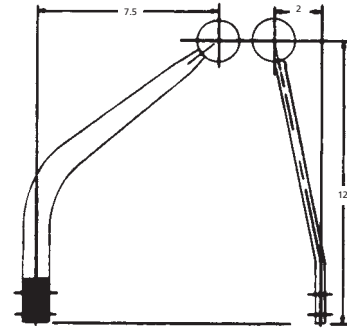

#538 0180

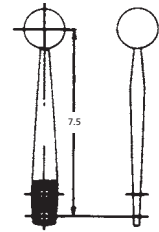

#538 0185
Used on shifters 391 7535,
391 0003, 391 7960, 491 0001

BLACK ANODIZED ALUMINUM FINISH

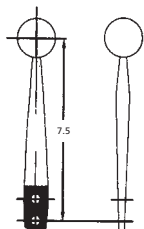

#538 0196
Used on shifters 391 0032,
391 5032, 391 5034

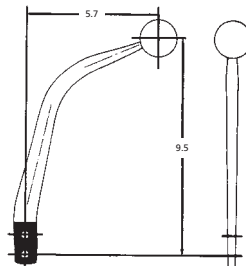

#538 0201
Used on shifter 391 0029

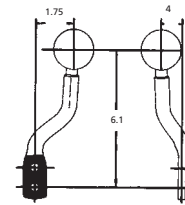

#538 0202
Used on shifter 391 0031

STEEL STICKS

Hurst steel sticks are constructed from a high strength steel and manufactured with Hurst quality.

BLACK STEEL STICKS

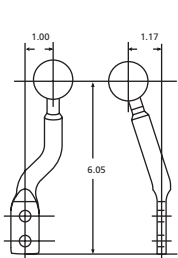

#238 5197
fits shifters 391 5030, 391 5072
12mm x 1.75 thread

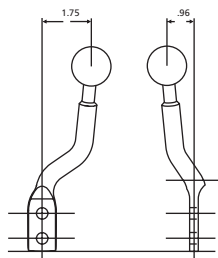

#238 5202
fits shifters 391 5031, 391 5070
12mm x 1.75 thread

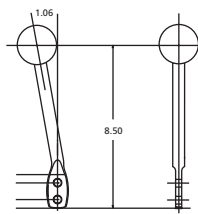

#238 8572
fits shifter 391 5060
16mm x 1.50 thread

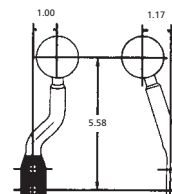

#538 0197
Used on shifters 391 0030, 391 0070
7/16-20 thread

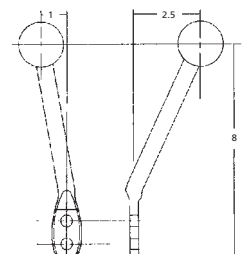

#538 8570
Used on shifter 391 0060
16mm x 1.50 thread



SHIFTER STICKS

STEEL STICKS

CHROME-PLATED STEEL STICKS

Hurst "bolt-on" shifter sticks are ideal for use in custom applications where a particular height or offset is required. These shifter sticks are constructed from high strength steel and are stamped with the Hurst name. All sticks incorporate a 3/8-16 thread size for use with many popular Hurst T-handles and shifter knobs. Bolthole size is 3/8" I.D. with 7/8" center-to-center spacing.

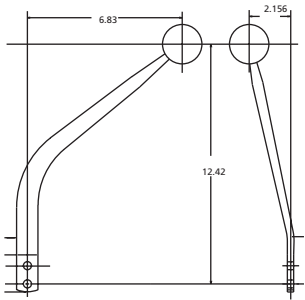

#238 0090
fits shifters 391 5040, 391 0033

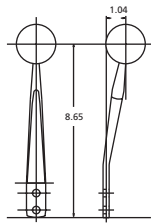

#238 0131
fits shifter 391 0028

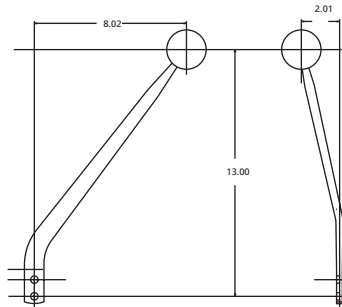

#238 0290
fits shifter 391 0110

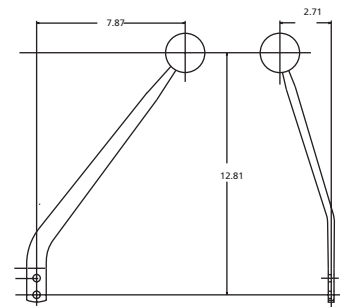

#238 0291
fits shifter 391 0120, 391 0121

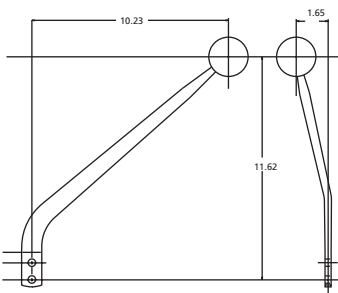

#238 0292
fits shifters 391 5050,
391 0111, 391 0155

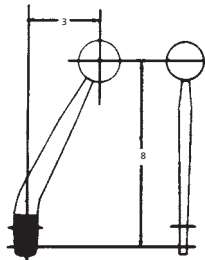

#538 0015
Used on shifters
391 8790, 366 0005

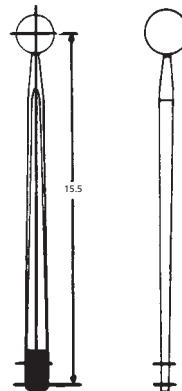

#538 0060
Used on shifter 366 0010

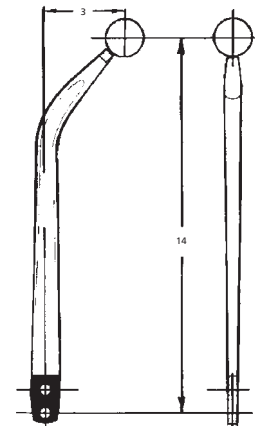

#238 0085
Used on shifter 391 0024

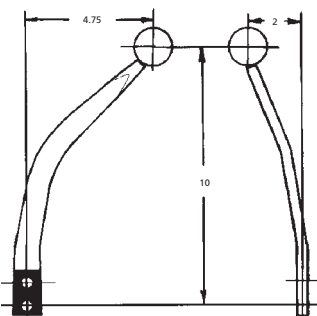

#538 0100
Used on shifter 407 0009

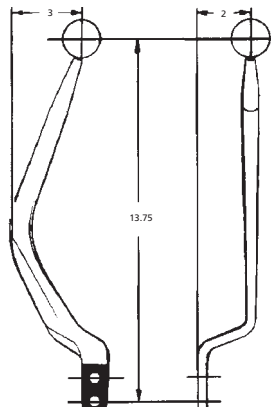

#538 0221

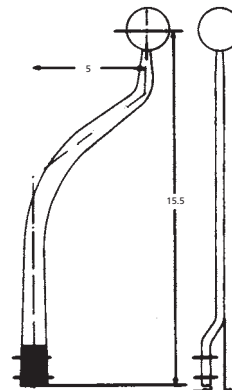

#538 4077

SHIFTER STICKS

STEEL STICKS

CHROME-PLATED STEEL STICKS

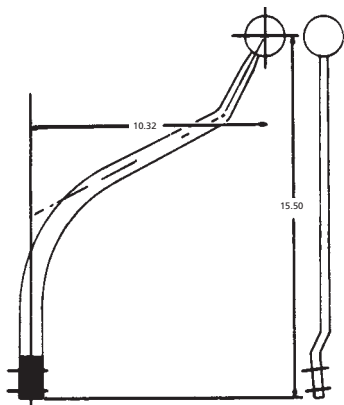

#538 4078
Used on shifter 391 6789

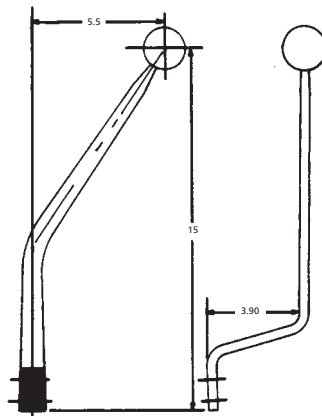

#538 4084
Used on shifter 391 6790

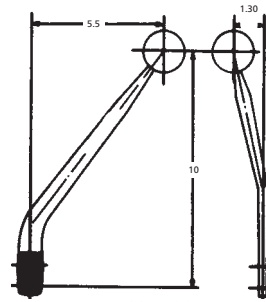

#538 4106
Used on shifters 391 4339,
391 7879, 366 4550

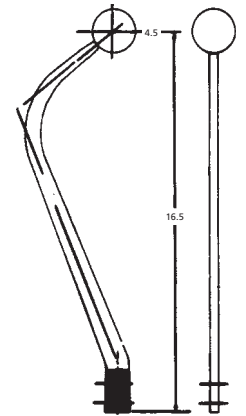

#538 4331
Used on shifters 391 0001,
391 0002, 366 6809

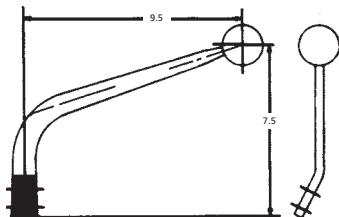

#538 6643

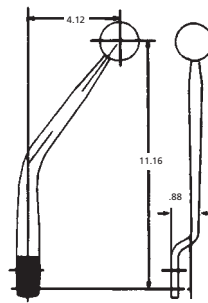

#538 6836
Used on shifters 391 6822,
391 7072, 391 6848

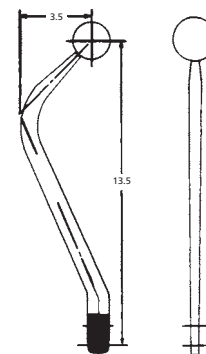

#538 6900
Used on shifters 366 6901,
391 8403, 391 8404, 391 5045

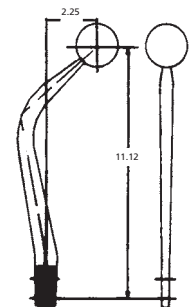

#538 7236
Used on shifters 391 7308,
391 7307, 391 7930, 366 7271

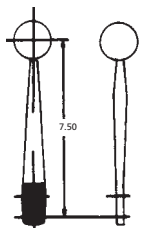

#538 7238
Used on shifters 391 7535,
391 5061, 391 7960

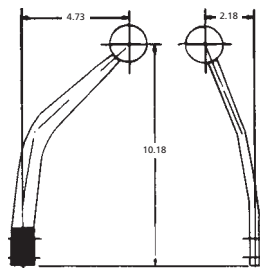

#538 7436
Used on shifters
391 7438, 366 7954

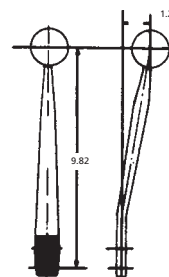

#538 7991
Used on shifter
391 7992

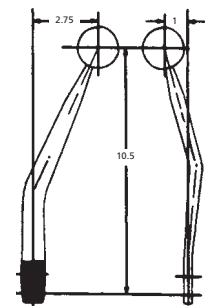

#538 8009
Used on shifters 391 8014,
391 8791, 391 8794

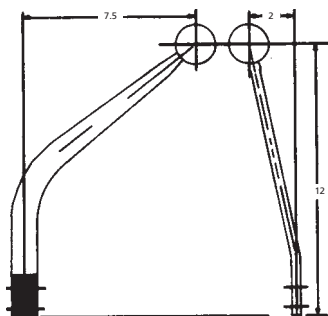

#538 8022
Used on shifter 366 8034

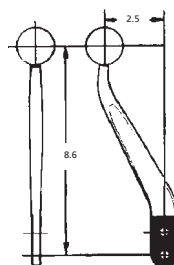

#538 8550
Used on shifter 391 0035,
391 0036, 319 0112

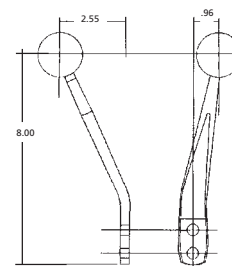

#538 8571
Used on shifter 391 0061



MANUAL SHIFTER ASSEMBLIES

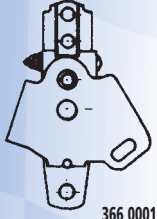

366 0001

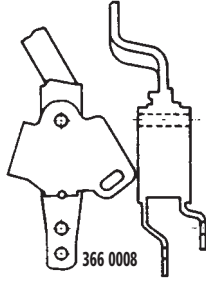

366 0008

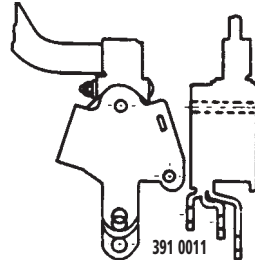

391 0011

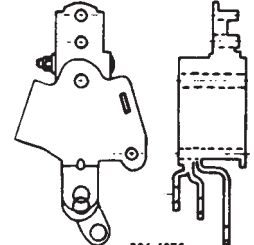

391 4076
391 7993

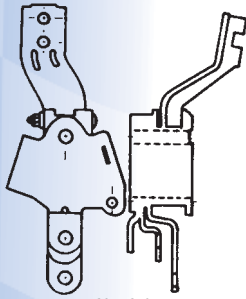

391 4340
391 6644

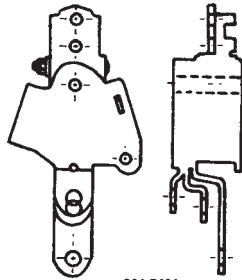

391 5401
391 7535

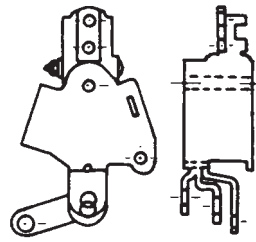

391 5405
391 7960

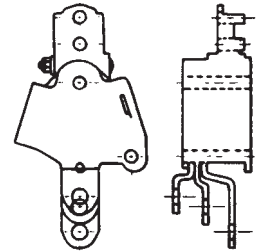

391 5043
391 6817

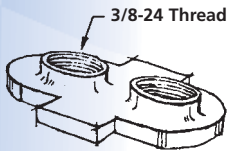
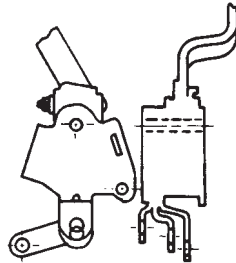
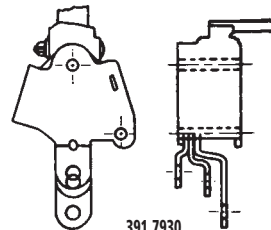

Plate Stiffener
195 0053



391 0014



391 7930

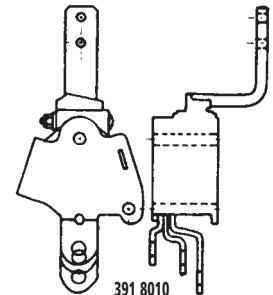

391 8010
391 8394
391 8793

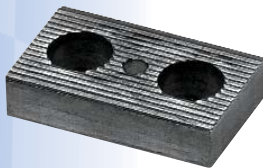

Spacer Block
228 8397

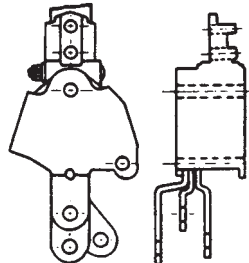

391 8787

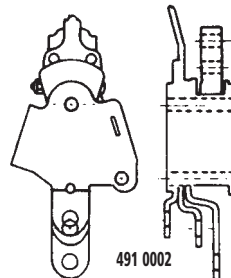

491 0002

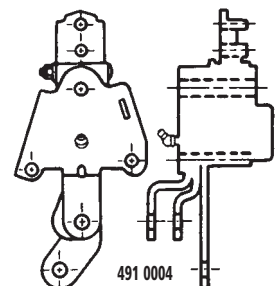

491 0004

AUTOMATIC TRANSMISSION I.D. CHART

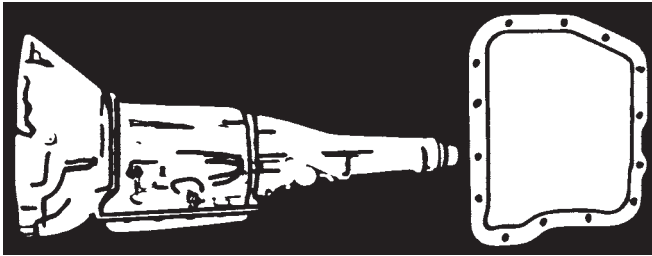

221 TORQUEFLITE 727
Chrysler Corporation 66-81

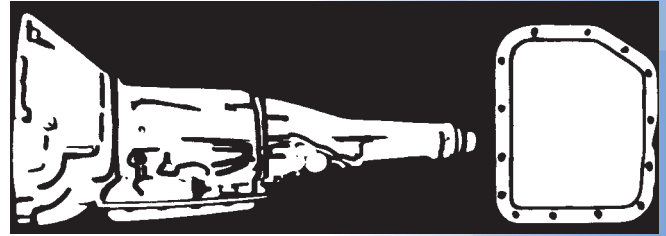

222 TORQUEFLITE 904
Chrysler Corporation 66-81

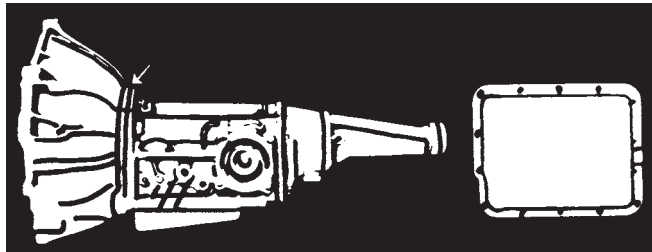

231 FORD C-4
Ford Motor Co. 64-81

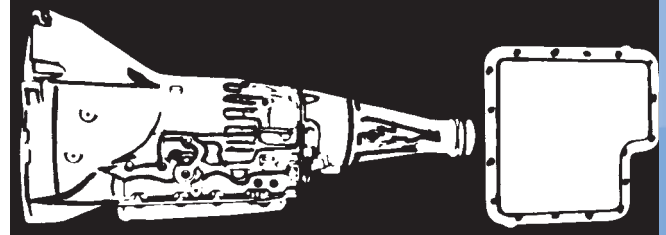

232 FORD C-6
Ford Motor Co. 66 & Later

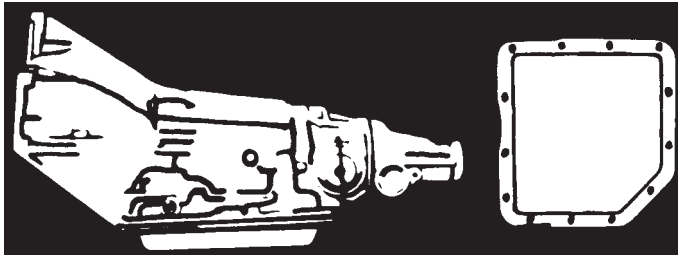

242 TURBO-HYDRAMATIC 250 & 350
General Motors 68 & Later

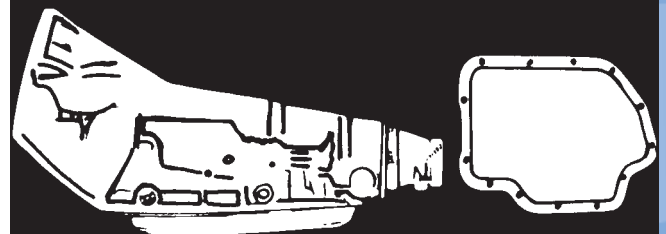

243 TURBO-HYDRAMATIC 400 & 375
General Motors 65 & Later

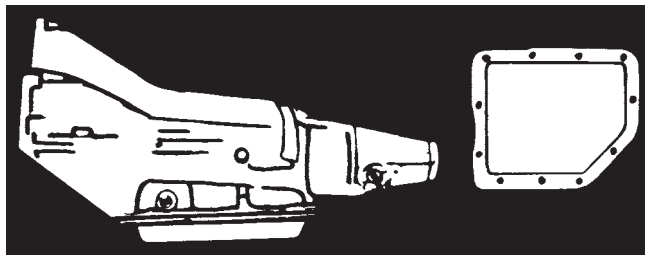

244 TURBO-HYDRAMATIC 200 (METRIC)
General Motors 76 & Later



245 POWERGLIDE
General Motors 63-73

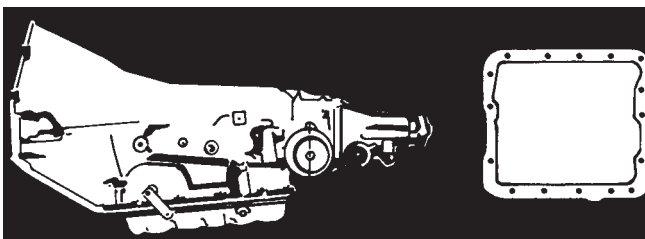

246 TURBO-HYDRAMATIC 700R4
General Motors 81 & Later

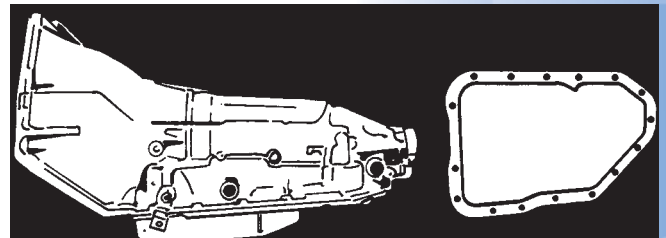

247 TURBO-HYDRAMATIC 200 4R
General Motors 81 & Later



3-SPEED TRANSMISSION I.D. CHART

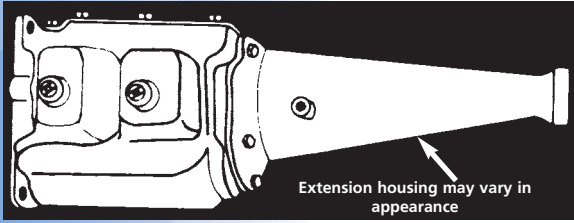

Extension housing may vary in appearance

333 FORD
9 bolt top cover; first gear synchronized

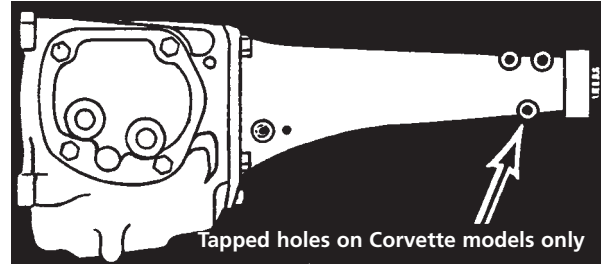

Tapped holes on Corvette models only

341 CHEVROLET
4 bolt side cover with round gear selection shafts

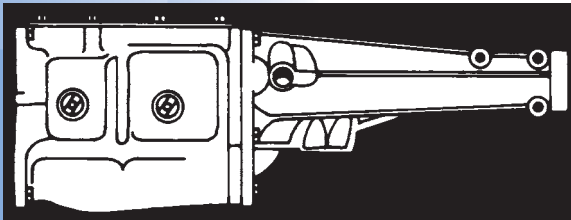

336 FORD
9 bolt top cover; first gear synchronized

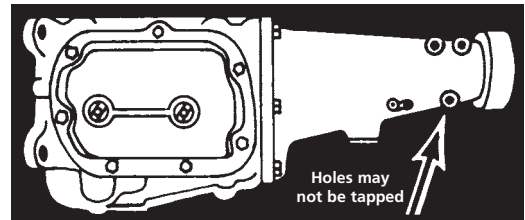

Holes may not be tapped

343 SAGINAW
7 bolt side cover; first gear synchronized
CAUTION: This transmission closely resembles 351 Muncie

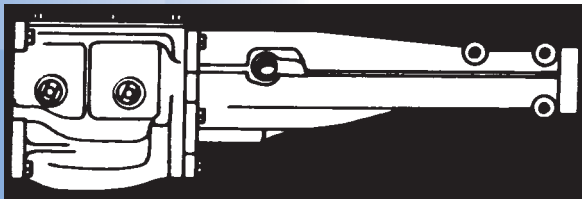

337 FORD
4 or 6 bolt top cover; first gear not synchronized

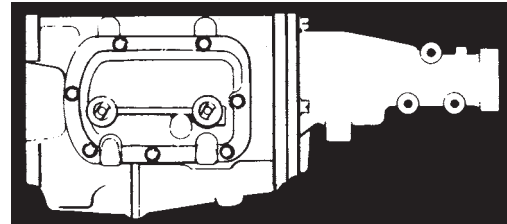

351 MUNCIE
7 bolt side cover; first gear synchronized
CAUTION: This transmission closely resembles 343 Saginaw

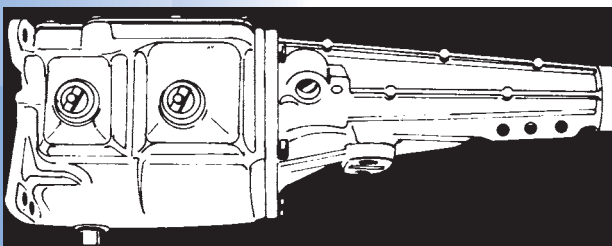

339 FORD
9 bolt top cover; first gear synchronized

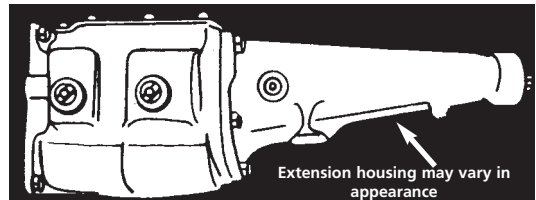

Extension housing may vary in appearance

352 TREMEC
9 bolt top cover; first gear synchronized

4-SPEED TRANSMISSION I.D. CHART



Early models have only these tapped holes

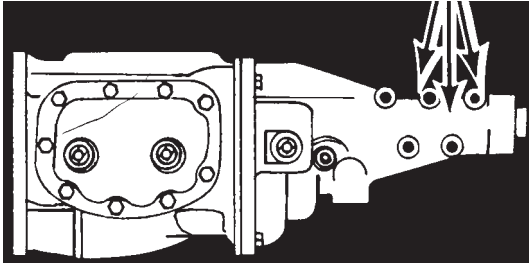

**410 BORG-WARNER T-10,
(AS-3), G. M.**
9 bolt curved bottom side cover

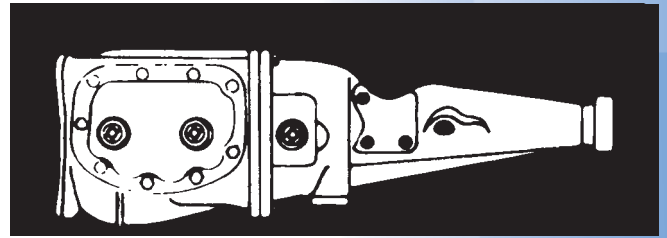

**411 BORG-WARNER T-10, SUPER T-10,
FORD/MERCURY**
9 bolt curved bottom side cover

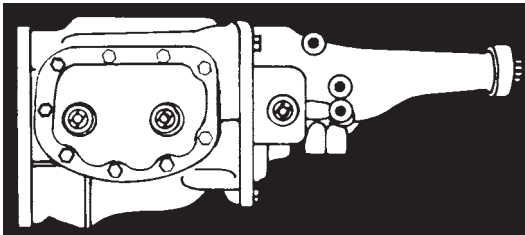

**412 BORG-WARNER T-10,
FORD/MERCURY**
9 bolt curved bottom side cover

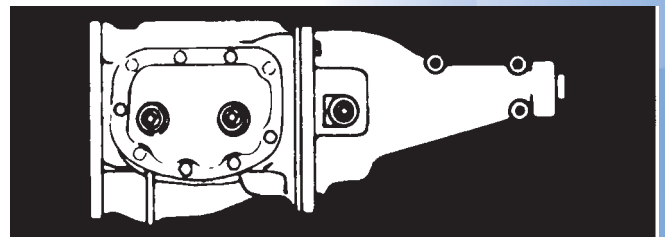

**413 BORG-WARNER T-10
FORD/MERCURY**
9 bolt curved bottom side cover

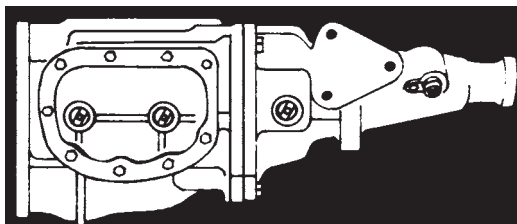

**414 BORG-WARNER T-10,
FORD/MERCURY**
9 bolt curved bottom side cover

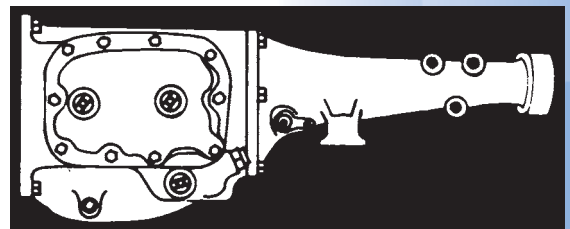

**421 NEW PROCESS, MOPAR
A-BODY**
10 bolt side cover

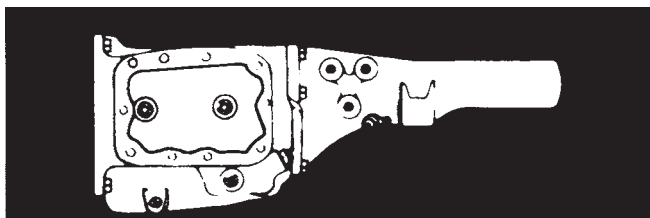

422 NEW PROCESS, MOPAR B-BODY
10 bolt side cover

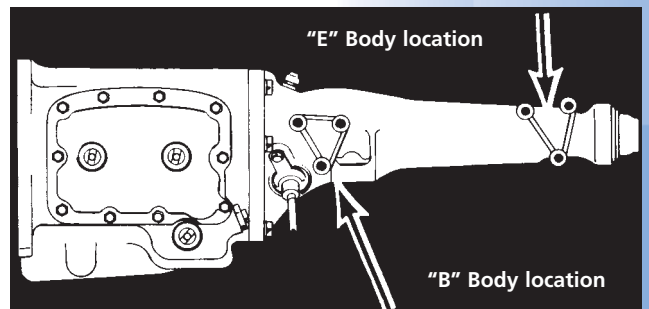

423 NEW PROCESS, MOPAR
10 bolt side cover



4-SPEED TRANSMISSION I.D. CHART

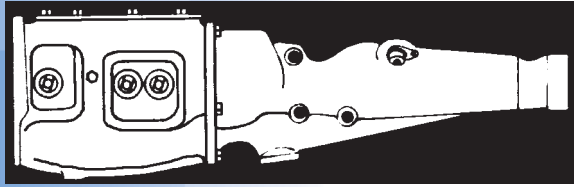

431 FORD T & C, FORD/MERCURY
10 bolt top cover

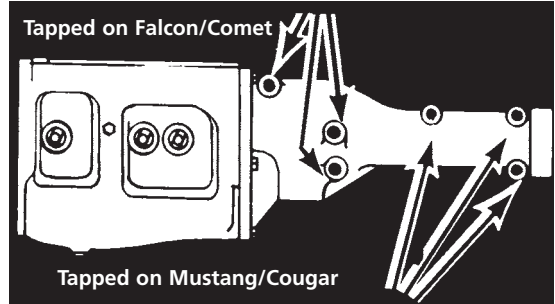

Tapped on Falcon/Comet
432 FORD 3+1 OVERDRIVE T & C, FORD/MERCURY
10 bolt top cover

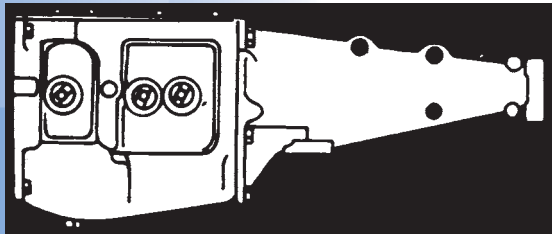

433 FORD T & C, FORD/MERCURY
10 bolt top cover

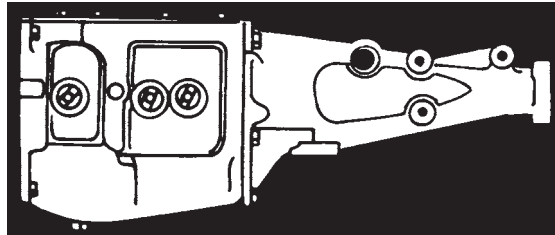

434 FORD T & C, FORD/MERCURY
10 bolt top cover

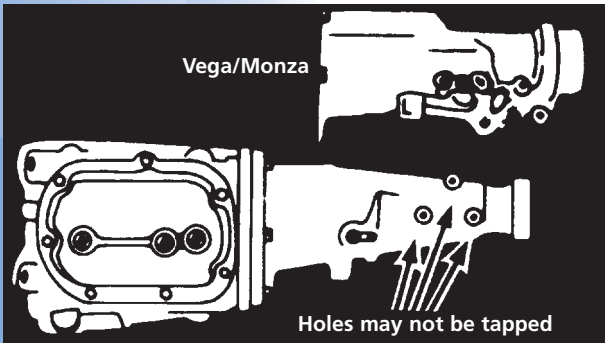

Vega/Monza
441 SAGINAW, G.M.
7 bolt side cover

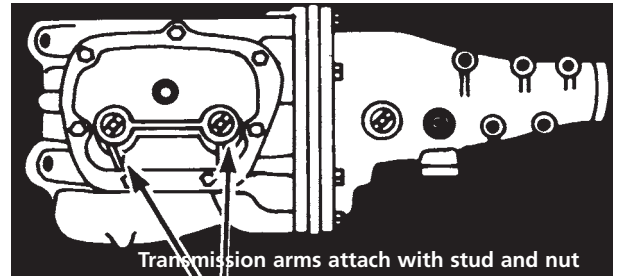

Transmission arms attach with stud and nut
451 MUNCIE M-21 EARLY, G.M.
7 bolt side cover used from 1963-68

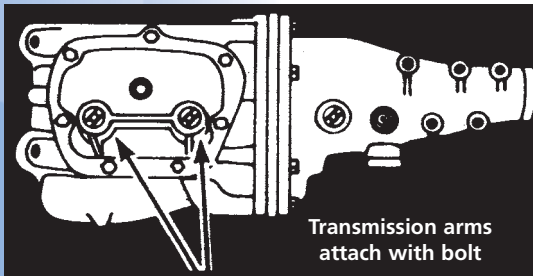

Transmission arms attach with bolt
452 MUNCIE, G.M.
7 bolt side cover 1969 and later

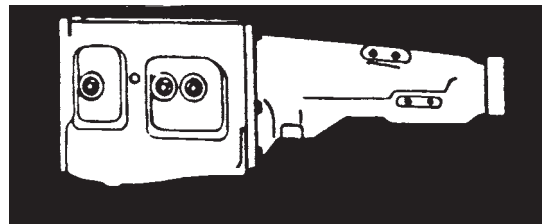

435 FORD 3+1 OVERDRIVE FORD/MERCURY

4, 5 & 6-SPEED TRANSMISSION I.D. CHART

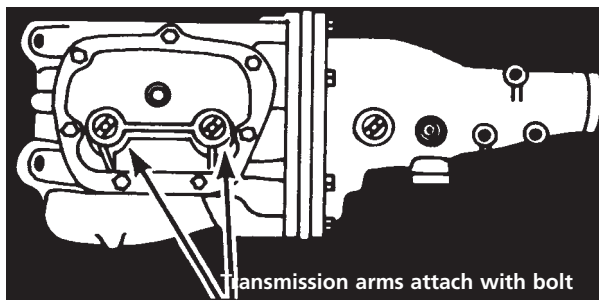

453 MUNCIE M-22
G.M. 7 bolt side cover 1970, 454 Chevelle

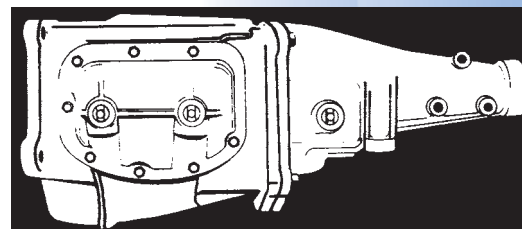

454 RICHMOND/BORG-WARNER SUPER T-10, (AS-9) 1974 and later
9 bolt curved bottom side cover

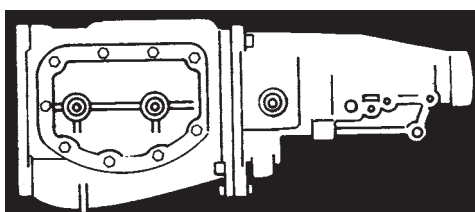

455 BORG-WARNER TORQUE TUBE TAILSHAFT, G.M.
81-82 CAMARO/FIREBIRD 9 bolt side cover

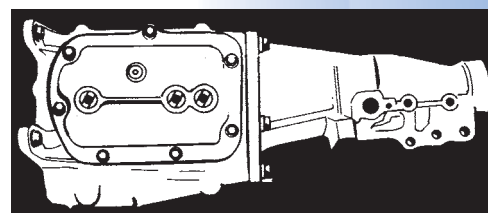

456 SAGINAW TORQUE TUBE TAILSHAFT, G.M., 81-82 CAMARO/FIREBIRD
7 bolt side cover

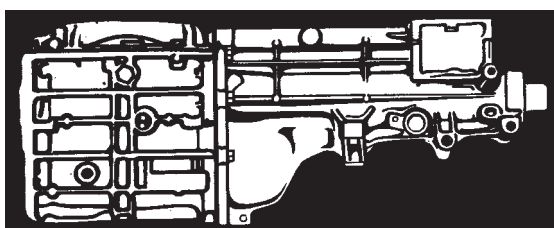

464 BORG-WARNER T-4, T-5 GENERAL MOTORS
Internal Rail

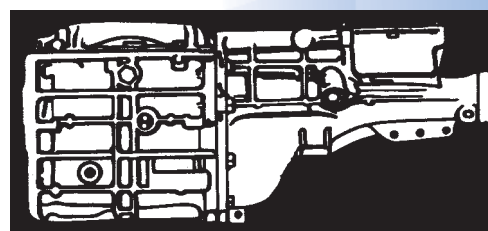

465 BORG-WARNER T-5, FORD
Internal Rail

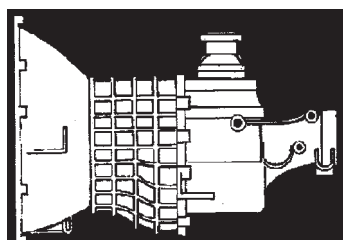

466 NEW VENTURE MG-5,
G.M. & DODGE TRUCK

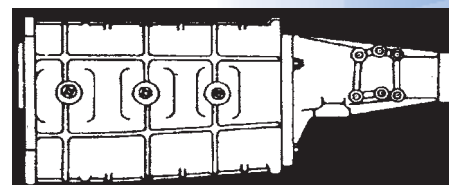

467 RICHMOND GEAR DOUG NASH/G-FORCE 5-SPEED

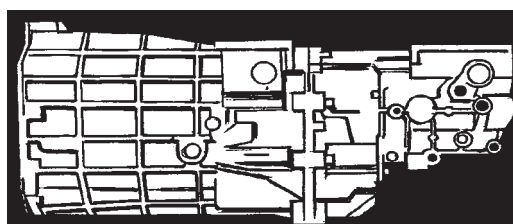

468 BORG-WARNER T-56, G.M.

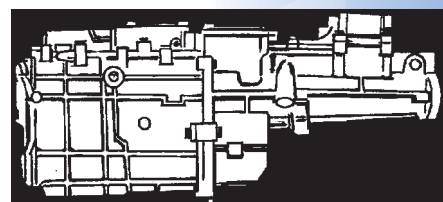

469 TREMEC 3550



PROMOTIONAL ITEMS



HURST NOSTALGIA CAP

Relive the era of 1965 when the spectator stands at the U.S. Nationals in Indianapolis was a sea of yellow as everyone at the raceway was given one of these caps to promote Hurst Shifters. Made of premium quality materials and construction, this bright yellow cap features a black edge bill with large nostalgia Hurst logo and Velcro strap for easy adjustment. 74108G

HURST NOSTALGIA T-SHIRT

Constructed from premium quality 100% pre-shrunk cotton and printed in vivid, fade-resistant colors, these quality made tee's have a bold racing stripe with logo on the front and a large nostalgia Hurst logo on the back.



- 74109G Small
- 74110G Medium
- 74111G Large
- 74112G X-Large
- 74113G 2X-Large
- 74114G 3X-Large



HURST LOGO CAP

Hot new head gear! Made with premium quality materials and construction, this Hurst racing cap is sure to set off some alarms. Hat features a Velcro strap for easy adjustment. 74045G

HURST FLAMED SPORT SHIRTS

You'll be turning up the heat with these stylish flame sport shirts! These 60/40 cotton/polyester honeycomb pique knit fabric shirts feature a knit collar and sleeve welts with a hot rod flame design. The bottom hem is finished with side vents for in or out wear.



- 73758G Small
- 73759G Medium
- 73760G Large
- 73761G XLarge
- 73762G 2Xlarge
- 73763G 3Xlarge

HURST RACING KNIT SPORT SHIRTS

The perfect combination of comfort and style!

Made from 100% combed ring-spun cotton, these shirts feature a tipped collar and inside placket with racing check sleeve bands, and a three button contrasting body placket. Hemmed garment bottom.



- 73788G Small
- 73789G Medium
- 73790G Large
- 73791G XLarge
- 73792G 2Xlarge
- 73793G 3Xlarge

PROMOTIONAL ITEMS



HURST JUMP SUIT T-SHIRT

Hang onto your handles, here's another hot one from Hurst! This cotton tee sports a curvy lady in a jumpsuit, and the phrase "Shift Happens!"



Small 73633G,
Medium 73634G,
Large 73635G,
XLarge 73636G,
2XLarge 73637G,
3XLarge 73638G,
4XLarge 73639G



HURST FLAMED LIGHTWEIGHT JACKET

When the temperature falls, turn up the heat with this flame racing jacket! Featuring a 100% Nylon Tasion shell with 600mm water resistant PU coating, full front zipper, two angled waist slash pockets and one interior right chest pocket, as well as inset sleeves with shirred elastic cuffs. Not to mention totally cool flame graphics that wrap around from front to back and embroidered Hurst logo! 73716G Small, 73717G Medium, 73718G Large, 73719G XLarge, 73720G 2XLarge, 73721G 3XLarge

HURST SEAT BELTS T-SHIRT

America's Number One Shifter Company has a grip on style with this edgy tee featuring the phrase "Shift Happens" and a lady with strategically placed seat belts — you're sure to turn heads with this one!



Small 73626G,
Medium 73627G,
Large 73628G,
XLarge 73629G,
2XLarge 73630G,
3XLarge 73631G,
4XLarge 73632G



PERFORMANCE WINTER JACKETS

This quality constructed, ultra-durable winter jacket will keep you warm in style! Its oversized construction features tri-colored horizontal design, set-in sleeves, quilt lining, and a full zipper with storm flap & snaps. Other details include a zip-through collar with accent stripe, elastic trim at the cuffs and waistband, and matching pocket welts. Machine washable. 73704G Small, 73705G Medium, 73706G Large, 73707G XLarge, 73708G 2XLarge, 73709G 3XLarge

KNIT SKI CAPS

Keep your head warm on those cold days & nights! This long beanie (approx. 13 inches) is made from 100% Acrylic with a wool feel. 73825G Mr. Gasket Racing, 73826G Mallory Racing, 73827G Hurst Racing





PROMOTIONAL ITEMS



HURST EQUIPPED EMBLEM

Based on original HURST blueprints, this HURST EQUIPPED emblem is an authentic reproduction of the one used on the late '60's muscle cars equipped with a factory Hurst shifter. Made of durable ABS plastic with 3M adhesive tape backing for permanent mounting. Nominal size is 1-1/4" high by 5-1/4" long. Individually packaged. Part No. 136 1000



HURST COLLECTABLE CAR

HURST celebrates its 45th Anniversary with a flamed out '32 Ford Sedan Delivery Open Wheel Street Rod. This is a 1/25th scale collectable model manufactured by SpecCast. There have only been 3,500 produced. 73970G

NOSTALGIA DECALS

These Hurst, Hays and Mr. Gasket decals are real collector items and have been authentically reproduced from the past when these companies were just getting started in the high performance industry. Silk screened on vinyl and die cut for easy removal with self adhesive back for adhesion to any clean dry surface. 132 0010



INDIVIDUAL BRAND DECALS

Silk screened on vinyl, these self-adhesive decals stick to any clean, dry surface.

- Hurst Logo, 5-1/2" x 6-1/4" Part No. 132 0009
- Mr. Gasket Logo, 5" x 1-1/4" Part No. 4
- Mr. Gasket Logo, 11-1/2" x 3", contingency size Part No. 4A
- Hays Logo, 5" x 8" Part No. 75-701
- Lakewood Logo, 6-1/2" x 6-3/4" Part No. 60030
- ACCEL Logo, 3-3/4" x 9-1/2" Part No. M23957



EMBROIDERED, SEWN-ON PATCHES

- | | | |
|------------|----------------------------|--------|
| HURST | Size: 1-7/8" h X 2-14" w | 73923G |
| HAYS | Size: 1-3/8" h X 2-3/16" w | 73924G |
| LAKEWOOD | Size: 1-1/2" h x 1-5/8" w | 73925G |
| MR. GASKET | Size: 1" h x 4-1/8" w | 73926G |
| ACCEL | Size: 1-1/8" h x 2-7/8" w | 73927G |
| MALLORY | Size: 1-3/8" h x 2-7/8" w | 73928G |



VINTAGE HURST SHIFTERS, A Complete Guide - Volume 1

A complete and comprehensive guide to "vintage" Hurst manual shifters, including company history, marketing programs, shifter identification, dimensional drawings, catalog excerpts and reprints of nearly 25 early Hurst shifter instruction sheets.

The book includes numerous original, unpublished Hurst photos along with historical background information and personal insight. An invaluable reference book for automobile restorers, collectors and enthusiasts who buy and sell used car parts.

This highly recommended authoritative publication is written by Pete Serio and is only available from your local bookstore under the ISBN 0-9749004-0-0 part number.

HURST HEMI UNDER GLASS Die Cast Metal Replica Car Personally Autographed by Bob Riggle

A VERY LIMITED number of HURST HEMI UNDER GLASS 1:64 scale replica cars are available through Hurst, autographed by the original car builder and driver Bob Riggle!

Bob has been driving the rear engine '68 Plymouth Barracuda powered by a 426 Chrysler Hemi for over 35 years at race tracks all over the world, and has agreed to personally sign a limited number of these replicas.

Now out of production, these replicas are from the JOHNNY LIGHTNING SHOWSTOPPER series and are very difficult to obtain. Once our supplies are gone, no more will be available. Part No. 378 0463



Bob Riggle

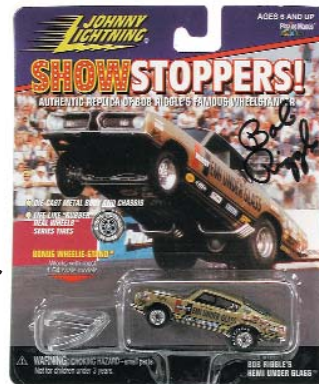

PROMOTIONAL ITEMS



FLAME T-SHIRTS

These new tees are on fire! Featuring the Mr. Gasket Performance Group flamed logo, as well as all of our brand logos, these 100% cotton T-shirts will make you a hot item! Available in white and oatmeal.

WHITE, Small 73601G, Medium 73602G, Large 73603G, XLarge 73604G, 2XLarge 73605G, 3XLarge 73606G

OATMEAL, Small 73607G, Medium 73608G, Large 73609G, XLarge 73610G, 2XLarge 73611G, 3XLarge 73612G

MR. GASKET PERFORMANCE GROUP APRON

Perfect for keeping you clean while working on your car, or at your backyard grill! This full-length adjustable apron is made from a 65% cotton/35% polyester blend, and features two pockets and adjustable straps. 73830G



PERFORMANCE BANNER

Ideal for use at the races, in performance shops and on garage walls, these banners are made from heavy gauge plastic and measure approximately 3' X 6'. Designed for outdoor and indoor usage, the banners have sewn edges for additional strength and brass plated corner eyelets for easy hanging. Part No. 72666G

TEMPORARY TATTOOS

The sun's not the only thing that's going to heat up your skin this summer! Check out these temporary tattoos of our famous brand logos in tribal and flame designs. Nothing could be cooler than these hot new tattoos! Card is 4" x 6".

73656G 7 logo design

73657G 5 logo design, The ACCEL tribal and Motorcycle logos are on this set.

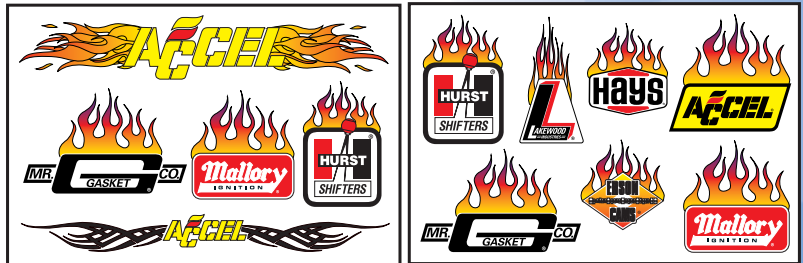

MR. GASKET LOGO GOLF BALLS

If you think that there is a longer ball, you don't know JACK! The Wilson JACK that is. Longest & Straightest! 73951G will get you one dozen golf balls.



ASSORTED BRAND DECALS

Silk screened on vinyl, these self-adhesive decals stick to any clean, dry surface. Assorted Mr. Gasket Performance Group Decals Part No. 7007G



NUMERICAL INDEX

PART NO.	PAGE	PART NO.	PAGE	PART NO.	PAGE	PART NO.	PAGE
60030	58	1052441	42, 43	1058030	45	1170099	41
1050004	40	1052442	42	1058031	45	1170144	40
1050005	40	1052445	42, 43	1058032	45	1170145	40
1050007	40	1052488	42	1058038	45	1170151	44
1050008	40	1052489	42	1058039	45	1170158	43
1050009	40	1052656	42	1058040	45	1170199	41
1050011	40	1052723	42	1058041	45	1170212	40
1050012	40	1052724	42	1058383	40-45	1174208	42, 43
1050016	40, 43	1052725	42	1058559	41	1174768	40
1050023	45	1053665	42	1058561	41	1174773	40
1050024	45	1053666	42	1058564	41	1174777	44
1050028	43	1053667	42, 43	1058566	41	1174778	40, 41
1050031	44	1053698	42	1058567	41	1174819	45
1050032	44	1053831	42	1058572	41	1175284	42
1050035	44	1053832	40, 43	1058573	45	1175711	40
1050036	44	1053894	40-43	1058574	45	1176889	42, 43
1050043	42, 45	1054293	40-43	1140010	37	1177154	44
1050044	42	1054294	40-43	1140024	37	1178227	44
1050049	43	1054295	42, 43	1141653	37	1178228	44
1050052	40, 43	1054346	42	1144580	37	1178557	41
1050053	45	1054347	42	1145001	37	1178558	41
1050054	44	1054746	44	1147336	37	1178560	41
1050055	40, 43	1054747	44	1147494	37	1178562	41
1050056	44	1054828	45	1148280	44	1178563	41
1050057	44	1054829	40, 43	1148429	37	1178565	41
1050058	44	1054864	42, 44	1148435	37	1178580	2, 3
1050059	11, 41	1054865	44	1148550	41	1190002	46
1050070	43	1055286	42	1148572	41	1198057PO	46
1050073	43	1055287	42	1160001	40	1198060	46
1050074	44	1057000	41	1160004	44	1260015	44
1050080	40, 41	1057058	40-45	1160007	44	1263705	46
1050081	40, 41	1057059	42	1160010	40, 43	1275702	46
1050082	40, 41	1057060	40-45	1160016	44	1290003	40
1050084	41	1057061	43	1160017	44	1290009	40
1050085	45	1057075	40-45	1160021	44	1298554	41
1050086	45	1057128	42	1160025	44	1300041	7, 41
1050087	45	1057129	42, 43	1161734	44	1300055	7
1050089	44	1057130	42-44	1162319	44	1300056	7
1050090	44	1057135	44	1167153	44	1320009	58
1050093	45	1057144	44	1170006	44	1320010	58
1050094	45	1057645	44	1170007	44	1340003	44
1050095	45	1057646	42	1170037	40, 41	1340004	44
1050098	41	1057647	40-43	1170038	40, 41	1361000	11, 35, 58
1051526	44	1057656	44	1170044	44	1400009	40
1051550	44	1057825	42, 43	1170045	44	1400020	41
1051573	44	1057899	42, 43	1170061	44	1530003	33, 35
1051657	44	1057923	42	1170062	44	1530006	33, 35
1051670	42	1058000	45	1170071	44	1530018	36
1051779	44	1058006	45	1170084	40, 43	1530019	36
1052108	42, 44	1058016	45	1170092	40	1530026	35
1052140	40, 42	1058025	45	1170094	40, 41	1530027	35
1052141	40-45	1058026	45	1170095	41	1530032	36
1052142	42	1058027	45	1170096	44	1530033	36
1052320	44	1058028	45	1170097	44	1534758	35
1052440	42, 43	1058029	45	1170098	41	1534813	35, 40

NUMERICAL INDEX



PART NO.	PAGE	PART NO.	PAGE	PART NO.	PAGE	PART NO.	PAGE
1534900	35	1543154	42	1590135	43	1598174	45
1534910	33, 35	1543183	42	1590136	43	1598175	45
1534950	35	1543398	46	1590137	43	1598180	45
1534960	33, 35	1544088	42	1590139	43	1598182	45
1535000	36	1544097	42, 43	1590141	45	1598188	45
1536000	36	1544242	42	1590144	45	1598190	45
1536010	36	1544353	42	1590147	45	1598193	45
1536020	36	1545289	42	1590155	40	1613706	46
1536030	36	1546821	42, 43	1590156	44	1630002	34
1536120	36	1547813	40, 43	1590166	44	1630003	34
1536130	36	1547922	42, 43	1590168	42	1630004	34
1536200	33	1548006	40, 43	1590177	45	1630008	34
1538430	36	1548164	45	1590181	42	1630014	34
1538500	35	1548165	45	1590269	42	1630016	34
1538501	35	1548171	45	1590274	42	1630022	34
1538510	7, 33, 35	1548172	45	1590279	42	1630025	34
1540002	40	1548174	45	1590307	42	1630034	44
1540009	44	1548175	45	1590344	42	1630037	34
1540010	44	1548180	45	1590375	42	1630038	34
1540013	44	1548182	45	1590381	42	1630040	34
1540016	44	1548188	45	1590391	42	1630049	33, 35
1540024	44	1548190	45	1590412	42	1630050	7, 35
1540025	44	1548193	45	1590425	42	1630051	35
1540053	44	1548374	40, 43	1590463	42	1630052	35
1540061	43	1548390	40	1590464	42	1630055	34
1540070	43	1550010	37	1590598	42	1630056	34
1540071	42-44	1550015	37	1590676	42	1630060	34
1540073	42	1550020	37	1590765	42	1630061	34
1540076	44	1550025	37	1590796	42	1630062	34
1540081	43	1550030	37	1590801	42	1630069	35
1540095	44	1550033	37	1590802	42	1630070	35
1540109	45	1550036	37	1590812	42	1630076	35
1540110	40	1550100	11	1590813	42	1630102	34
1540116	40, 43	1550120	11	1590822	42	1630103	34
1540117	45	1570126	40	1590823	42	1630104	34
1540119	45	1590003	44	1590876	40	1630108	34
1540121	45	1590014	44	1590925	43	1630114	34
1540128	40	1590017	44	1590927	44	1630116	34
1540130	44	1590020	44	1590938	43	1630125	34
1540131	42	1590022	40	1590981	42, 43	1630140	34
1540136	40	1590061	43	1590997	42	1630155	34
1540137	40	1590063	44	1590998	41	1630156	34
1540150	43	1590070	43	1590999	41	1630160	34
1540162	42	1590075	43	1591003	42	1631036	34
1540163	42	1590083	43	1591004	41	1631037	34
1540171	44	1590089	43	1591008	45	1632002	34
1540173	44	1590100	44	1591009	41	1632004	34
1540174	42	1590101	44	1591018	41	1632006	34
1540176	40	1590110	44	1591032	41	1632008	34
1540178	42	1590120	43	1591034	40	1632012	34
1540182	45	1590125	40	1591042	42	1632014	34
1540189	40	1590126	40	1598164	45	1632025	34
1543151	42	1590127	40	1598165	45	1635050	35
1543152	42	1590128	40	1598171	45	1635055	35
1543153	42	1590129	40	1598172	45	1637200	34, 40



NUMERICAL INDEX

PART NO.	PAGE	PART NO.	PAGE	PART NO.	PAGE	PART NO.	PAGE
1637624	34	2130024	44	2130209	40	2135298	42, 43
1637626	34	2130025	44	2130214	40	2135299	42, 43
1660002	40	2130030	43	2131562	44	2135307	42, 43
1690005	41	2130037	40, 43	2131588	40-44	2135308	42
1690006	41	2130038	40, 43	2131699	40, 43	2136100	45
1710016	44	2130039	40, 43	2131720	42	2136102	45
1745000	32	2130046	43	2131735	44	2136103	45
1801000	39	2130058	44	2131736	44	2136104	45
1802000	39	2130062	44	2132001	44	2136106	45
1890070	44	2130063	44	2132007	44	2136109	45
1890071	44	2130066	44	2132008	44	2136110	45
1890082	7	2130071	45	2132137	42, 43	2136111	45
1950037	40, 43	2130072	45	2132138	42	2136112	45
1950053	50	2130078	43	2132139	42, 43	2136113	45
1950122	40	2130079	40, 43	2132144	42	2136117	45
1950125	42	2130080	44	2132145	42, 43	2136118	45
1950133	45	2130084	45	2132146	42, 43	2136120	45
1950140	40	2130089	44	2132321	44	2136123	45
1950148	43	2130096	45	2132322	44, 45	2136124	45
1950163	42, 43	2130100	45	2132438	42	2136125	45
1950164	42	2130101	45	2132439	42	2136126	45
1950165	42, 43	2130105	45	2132444	42	2136127	45
1950167	44	2130106	45	2132485	42	2136134	45
1950168	44	2130110	45	2132486	42	2136135	45
1950199	42	2130135	42	2132487	42	2136162	45
1950222	45	2130136	42	2132726	42	2136163	45
1950225	7	2130137	42	2132727	42	2136164	45
1952298	40, 43	2130143	45	2132728	42	2136818	42, 43
1952482	42	2130144	45	2132758	42, 44	2137803	40, 43
1952722	42	2130145	45	2132774	42	2137819	40, 43
1952816	42	2130147	44	2132814	42	2138003	40, 43
1953176	42, 44	2130151	43	2132815	42, 43	2138037	40, 43
1954120	42	2130152	43	2132920	42, 43	2138377	40, 43
1954204	42	2130153	43	2133172	42, 44	2138378	40, 43
1954319	43	2130161	44	2133189	42	2138379	40, 43
1954345	42	2130162	44	2133207	42	2138697	45
1956348	42	2130163	42	2133404	42	2138698	45
1956834	42	2130164	42	2133601	44	2260020	5
1957773	42	2130165	42	2133646	42, 43	2288397	43, 50
1958008	42, 43	2130169	44	2133691	42	2305000	41, 46
1958382	40, 43	2130171	44	2133695	42	2308500	41, 46
1958551	41	2130173	44	2133830	42	2380077	40
1958574	41	2130175	44	2134093	44	2380085	43, 44, 48
1958657	45	2130177	44	2134147	42, 43	2380090	48
1958819	42	2130189	44	2134164	42	2380131	43, 48
1959026	45	2130190	40	2134187	42, 43	2380290	48
1959034	45	2130192	40	2134188	42, 43	2380291	48
1959037	45	2130193	42	2134209	44	2380292	48
1959038	45	2130194	42	2134210	44	2385197	47
1959044	45	2130195	42	2134335	42, 43	2385202	47
1959045	45	2130197	45	2134348	42	2388572	47
2130002	40	2130198	45	2134646	43	2410002	40
2130003	40	2130200	45	2134741	44	2410003	40
2130011	40	2130205	45	2134742	44	2410004	40
2130012	40	2130206	45	2134769	42, 43	2418552	41

NUMERICAL INDEX



PART NO.	PAGE	PART NO.	PAGE	PART NO.	PAGE	PART NO.	PAGE
2418553	41	3160030	4	3733668	15-17	3838521	3
2418567	41	3160088	41	3734089	15, 17	3838525	3
2418570	41	3162001	5	3734297	13, 14	3840002	30
2418571	41	3162006	5	3734354	14	3840003	30
2480003	11, 40	3162009	5	3734529	13, 14, 17	3840004	44
2480021	41	3162014	5	3734531	13, 17	3840005	44
2483875	32, 33	3162020	6	3734648	14	3840006	30
2483880	33	3162025	6	3734734	13, 14, 17, 18	3840007	44
2488600	7	3162030	5	3735587	15-17	3840012	30
2488601	7	3320001	46	3737131	14	3840013	30
2488605	11	3320002	46	3737437	13, 17	3840014	44
2654388	43, 44	3321000	22	3737637	15, 16	3840015	44
2655293	43	3321002	22	3737638	15, 16	3840016	30
2800001	46	3321657	46	3737638	15, 16	3840017	44
2854470	39	3327302	46	3737834	13, 14, 17, 18	3840022	30
2858601	38	3570028	44	3737897	13, 14, 17	3840023	30
2858602	38	3570029	44	3737919	13, 14, 18	3910001	14, 16, 18
2858611	38	3660001	44, 50	3738164	26	3910002	14, 18
2858612	38	3660008	44, 50	3738165	26	3910011	43, 50
2858630	38	3660014	21	3738171	26	3910014	43, 50
2858640	38	3663179	21	3738172	26	3910024	16
2858660	38	3666809	20, 21, 44	3738174	26	3910028	14
2916387	13	3666901	21, 44	3738175	26	3910029	14, 18
2916516	13, 14, 16	3667271	20, 21, 44	3738180	26	3910030	15, 16
2916550	15	3670006	20, 21	3738182	26	3910031	15, 16
2916551	15	3670010	21	3738188	26	3910033	15, 18
2916557	15, 16	3670013	21	3738190	26	3910035	15
2916558	15	3670014	21	3738193	26	3910036	15
2916561	13, 14	3670023	21	3738605	13	3910037	43
2917634	15, 16	3670025	21	3738607	13	3910038	43
2917835	14	3670027	21	3738609	13, 14, 17, 18	3910039	45
2918487	14	3673111	21	3738611	14	3910040	43
2918488	13	3673112	21	3738615	19	3910041	43
2920000	9	3677143	21	3738616	19	3910051	43
2920001	9	3677640	21	3738617	19	3910056	43
2920003	40	3730006	27	3738618	19	3910057	43
2920004	40	3730007	27	3738620	16	3910069	43
2920006	9, 40	3730011	27	3738621	14	3910070	15
2920007	9, 40	3730014	27	3780463	58	3910110	14, 18
3078576	41	3730017	14, 16, 17	3830005	40	3910111	14, 18
3160001	4	3730018	44	3830012	8	3910112	14, 18
3160003	41	3730019	44	3835680	10	3910113	14, 18
3160006	4	3730020	44	3835681	10	3910119	43
3160008	41	3730021	13, 17	3835690	10	3910120	14, 18
3160009	4	3730022	"13,17	3835691	10	3910121	14, 18
3160011	41	3730024	31	3838500	2	3910122	14, 18
3160014	4	3730025	31	3838504	2	3910131	16
3160016	4	3733157	13, 14"	3838505	2	3910140	16, 18
3160017	41	3733162	14	3838510	2	3910155	15, 18
3160018	41	3733163	13, 14, 16, 17, 18	3838511	2	3913180	15-17
3160020	6	3733164	15, 16	3838515	3	3913780	13, 43
3160021	41	3733166	15, 16	3838520	3	3914000	22
3160025	6	3733167	15, 16			3914002	22
3160026	41					3914004	22



NUMERICAL INDEX

PART NO.	PAGE	PART NO.	PAGE	PART NO.	PAGE	PART NO.	PAGE
3914008	22	3918791	13, 17	5384077	48	73639G	57
3914015	22	3918792	43	5384078	43, 49	73656G	59
3914025	22	3918793	43, 50	5384084	49	73657G	59
3914030	22	3918794	13, 14,	5384106	43, 49	73704G	57
3914076	43, 50		16, 17	5384331	43, 49	73705G	57
3914339	13, 14, 17	3918797	50	5386643	49	73706G	57
3914340	43, 50	4070009	28	5386836	43, 49	73707G	57
3915020	16, 18	4070010	45	5386900	44, 49	73708G	57
3915025	16, 18	4070015	28	5387236	43, 49	73709G	57
3915026	16, 18	4118156	26	5387238	43, 45	73716G	57
3915030	15	4118157	26	5387436	43, 49	73717G	57
3915031	12, 15, 16	4910001	27	5387991	43, 49	73718G	57
3915032	14, 17	4910002	45	5388009	43, 49	73719G	57
3915035	15	4910002	50	5388022	49	73720G	57
3915036	15	4910004	31, 50	5388550	43, 49	73721G	57
3915040	16, 18	4910010	31	5388570	43, 47	73758G	56
3915042	12, 16, 18	4910500	31	5388571	43, 49	73759G	56
3915043	16, 18	5000020	46	5500001	39	73760G	56
3915045	16, 18	5000023	46	5500002	39	73761G	56
3915050	15, 18	5000024	46	5667550	32	73762G	56
3915055	15	5000025	40, 46	5671500	32	73763G	56
3915060	14, 17	5000028	46	5671510	32	73788G	56
3915061	14, 17	5000029	46	5671515	32	73789G	56
3915070	15	5008555	41, 46	5671516	32	73790G	56
3915071	12	5010002	25	6500001	11	73791G	56
3915072	15	5010004	40	97001835	45	73792G	56
3915084	14	5010016	24	4	58	73793G	56
3915085	14	5010017	40	4A	58	73825G	57
3915401	43, 50	5010018	25	7007G	59	73826G	57
3915403	43	5030024	40	72666G	59	73827G	57
3915405	43, 50	5030030	23	73601G	59	73830G	59
3916644	50	5030031	23	73602G	59	73923G	58
3916788	15, 17	5030032	23	73603G	59	73924G	58
3916789	15, 17	5030033	23	73604G	59	73925G	58
3916790	15, 17	5060001	24	73605G	59	73926G	58
3916817	43, 50	5060003	40	73606G	59	73927G	58
3916822	43	5380015	48	73608G	59	73928G	58
3916848	13-17	5380035	15, 17	73609G	59	73951G	59
3917307	13, 14	5380036	15, 17	73610G	59	73970G	58
3917308	13, 14,	5380060	43, 48	73611G	59	74045G	56
	16, 17	5380090	43	73612G	59	74108G	56
3917438	13, 17	5380100	48	73626G	57	74109G	56
3917535	14, 19, 50	5380178	47	73627G	57	74110G	56
3917879	43	5380179	47	73628G	57	74112G	56
3917930	14, 43	5380180	47	73629G	57	74113G	56
3917960	13, 14,	5380185	47	73630G	57	74114G	56
	17, 50	5380196	43, 47	73631G	57	75-701	58
3917992	14, 43	5380197	43, 47	73632G	57	M23957	58
3917993	50	5380201	43, 47	73633G	57		
3918010	43, 50	5380202	43, 47	73634G	57		
3918014	14	5380221	48	73635G	57		
3918394	43, 50	5380290	43	73636G	57		
3918787	43	5380291	43	73637G	57		
3918789	15, 16	5381000	45	73638G	57		

SHIFTER & ACCESSORIES ASSORTMENT

This starter assortment includes the Pro-Matic 2, our most popular ratchet shifter for automatics, in addition to a variety of top selling "A" moving accessories to help increase sales of Hurst transmission products. Includes header card, panel display grid, hanger hooks and inventory tags.

Part No. 73560G



PART #	DESCRIPTION	QUANTITY
1144580	B-4 SHIFTER BOOT & PLATE	2
1147336	B-1 SHIFTER BOOT & PLATE	2
1147494	SUPER BOOT & PLATE	2
1361000	"HURST-EQUIPPED" EMBLEM	3
1530018	T-HANDLE, UNIVERSAL (METRIC)	1
1530019	T-HANDLE, UNIVERSAL (SAE THREAD)	1
1530032	T-HANDLE, CHROME PLATED (S.A.E.)	1
1630003	CLASSIC 4-SPD KNOB 3/8-16	1
1630014	CLASSIC 5-SPD KNOB 12MMx1.75	1
1630016	CLASSIC 6-SPD KNOB 16MMx1.50	1
1632002	SHIFT KNOB, SHORT-BLACK LEATHER	1
1632004	SHIFT KNOB, TALL-BLACK LEATHER	1
1632008	SHIFT KNOB, BILLET ALUM STYLE	2
1632012	KNOB, LEATHER/CARBON FIBER	1
1632014	KNOB, ALUMINUM/CARBON FIBER	1
1745000	ROLL/CONTROL W/STAINLESS VALVE	1
2858601	HOT SHIFT 2 GM TH 350	1
3320001	PIT PACK-NYLON BUSHINGS	3
3327302	PIT PACK-STEEL BUSHINGS	3
3838500	PRO-MATIC 2 AUTOMATIC SHIFTER	1
2854470	TRANSMISSION PAN DRAIN PLUG	1

HURST SHIFTER REBUILD SERVICE

Hurst offers a rebuild service for most Hurst aftermarket and Hurst OE shifters. Hurst can rebuild your Hurst shifter and make it feel like new again. All worn parts are replaced so the shifter operates as smoothly as the day you bought it. To obtain service, send the shifter (freight prepaid) and payment with a note describing any problems to:

**Hurst Performance Shifter Rebuild Service
550 Mallory Way, Carson City, NV 89701-5374**

Include your name, shipping address and daytime phone number.

Allow 5 weeks for a shifter rebuild: 15 working days for the actual rebuild and 7 days each way for shipping. Allow an additional week for Hurst OEM shifters.

To inquire about the status of your shifter sent to Hurst for rebuilding at the above address, call 775-882-6600 ext. 342, 8 a.m. – 4 p.m. PST.

REBUILD CHARGES and WARRANTY

The most accurate and up to date information can be found on our web site at: www.hurst-shifters.com. Please reference this information prior to sending your shifter in for rebuild or warranty claims.



PERFORMANCE
TRANSMISSION CONTROLS
& ACCESSORIES

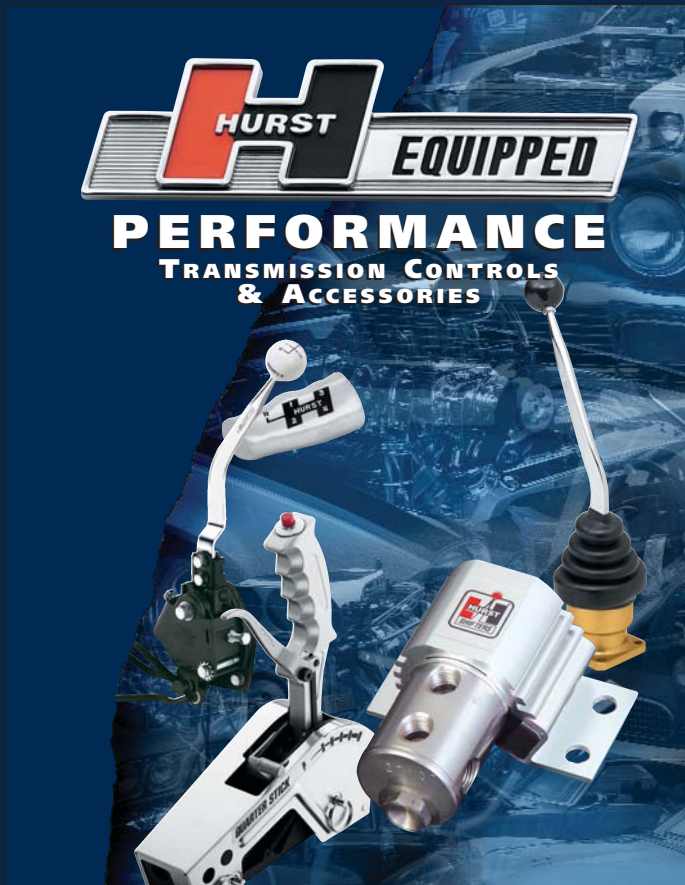

THE MR. GASKET PERFORMANCE GROUP
CLEVELAND, OHIO

©2004 Printed in U.S.A.

www.hurst-shifters.com

74086G

