

cooking collection

Instructions for use and warranty details

To register your warranty or make a warranty claim, scan this QR code:



Wall Mounted Canopy Rangehood
Model Nos: RHSC61, RHSC91 &
RHSC121

 **kleenmaid**

Dear Customer,

Thank you and congratulations for choosing Kleenmaid.

Your new appliance has been designed and meticulously tested to ensure that it meets all your culinary requirements, and has been carefully manufactured using top quality materials to give you years of reliable performance.

For best results, carefully read the instructions on how your new appliance is to be installed. Correct installation will avoid delays and unnecessary service call costs.

Once installation is complete, please read this instruction manual carefully and get to know the controls and the features of your new Kleenmaid appliance. These simple instructions will enable you to achieve excellent results from the very first time you use it.

Again, congratulations and thank you for choosing The Best You Can Own.

KLEENMAID

Table of Contents

• Important safety information	4-5
• Installation Instructions	6-7
• Installation Guidelines	8-9
Use and Care Instructions	10
• Operation	10-11
• Maintenance and Cleaning	12-14
• Rangehood Dimensions	15
• Troubleshooting	16
• Warranty Terms & Conditions	17

IMPORTANT SAFETY INFORMATION

Read the complete manual carefully before installation
The current online version of the User Manual is available on the Kleenmaid website (see back cover for details).

Intended for Domestic Kitchen Use Only

Warnings:

TO REDUCE THE RISK OF FIRE, ELECTRICAL SHOCK OR PERSONAL INJURY, PLEASE OBSERVE THE FOLLOWING:

- 1. Installation and electrical work must be done by a qualified person in accordance with all applicable codes and standards.**
- 2. If the supply cord is damaged, it must be replaced by the manufacturer, its service agent or a similarly qualified person to avoid a hazard. Any modifications that may be required to the electrical system for the installation of the rangehood must only be made by qualified electricians.**
- 3. Before servicing or cleaning unit, switch power off at the service panel. Lock panel to prevent power from being switched on accidentally.**
- 4. Use this unit only in the manner intended by the manufacturer.**
- 5. When cutting or drilling into wall or ceiling, be careful not to damage existing electrical wiring and other hidden utilities.**
- 6. Ducted fans must always be vented to the outdoors.**
- 7. This unit must be grounded.**
- 8. The safety gap between the rangehood and the hob below must comply with the recommendations of the hob manufacturer. In case of no instructions, a minimum distance of 650mm (or other minimum distance as may be specified by AS ZS 5601 and interpreted by a certified installer) should apply.**

CAUTION

- 1. To reduce the risk of fire and to properly exhaust air, be sure to duct air outside. Do not vent exhaust air into spaces within walls or ceiling or into attics, crawl spaces or garages.**
- 2. Take care when using cleaning agents or detergents.**
- 3. Avoid using food products that produce flames under the range hood.**
- 4. The range hood must only be used for the exhaust of cooking fumes in home kitchens. The manufacturer disclaims all liability for any other use of the appliance.**
- 5. Two installers are recommended because of the large size and weight of this hood.**
- 6. Use with approved cord-connection kit only.**
- 7. Please read specification label on product for further information and requirements.**
- 8. Do not flame under the range hood to avoid potential risk of fire.**
- 9. This appliance is not intended for use by persons (including children) with reduced physical, sensory or mental capabilities, or lack of experience and knowledge, unless they have been given supervision or instruction concerning use of the appliance by a person responsible for their well being.**
- 10. Children should be supervised to ensure that they do not play with the appliance.**
- 11. Cleaning and user maintenance should not be performed by children without supervision.**

INSTALLATION INSTRUCTIONS

Before You Start...

1. **NOTE:** Before making preparations for or commencing installation, the installer should refer to the current online version of the User Manual, which is available on the Kleenmaid website (see back cover for details).
2. The rangehoods conform to related appliances standards. Please check your local building codes for any additional requirements.
3. The appliance has been manufactured as class I, therefore ground connection is necessary. The rangehood must be installed so that that the plug is easily accessible.

Planning Your Installation

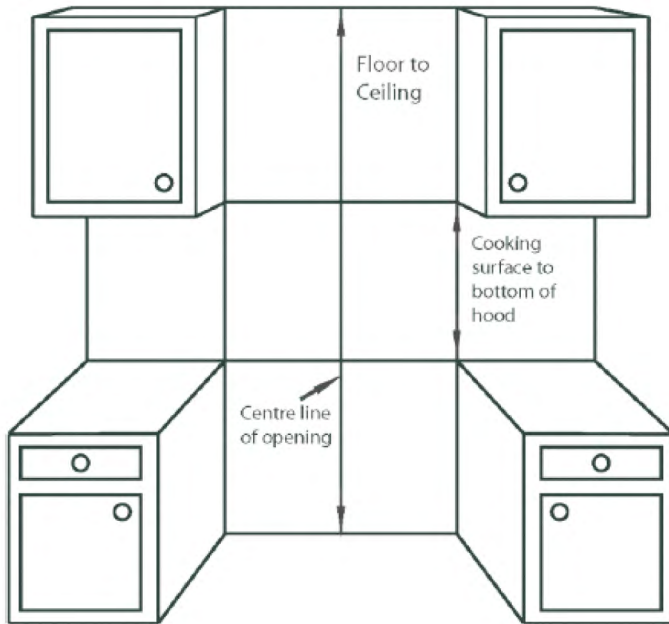
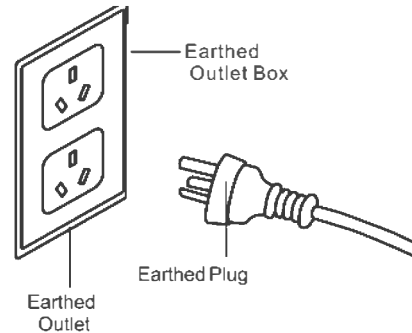

1. Calculate the maximum height from the floor at which the top of the decorative chimney duct may be located by adding the bench height to the chosen vertical separation between the rangehood and the cooktop below, and the height of the rangehood (see the diagram on page 15 for rangehood dimensions).

2. Find the centre point of your opening. Mark a plumb line through this point from ceiling to your cooktop.

3. Check your cooktop User Manual for the minimum distance above your cooking surface. The safety gap between the rangehood and the hob below must comply with the recommendations of the hob manufacturer. In case of no instructions, a minimum distance of 650mm (or other minimum distance as may be specified by AS/NZS 5601 and interpreted by a certified installer) should apply. The vertical separation distance shall not exceed 750mm so as not to adversely affect the extraction efficiency.

4. Decide where the ductwork will run between the hood and the outside. Short, straight duct runs will provide the most air flow.

5. If a recirculating kit is necessary, you may purchase one through your dealer.

Unpacking

Remove the packaging with the product in place. Cut off the packing ribbons and carefully cut open the packaging (do not cut too deeply), remove the packaging. Check that the product is free from transport damage. Any damage shall be reported immediately to the carrier or seller. Damage, faults and missing parts must be reported immediately to the seller. There are appliance specific accessories supplied with the rangehood which should be retained for installation and not discarded with packaging.

Installing the Ductwork

1. Plan where the ductwork will run between the rangehood and the outside. The rangehood exhausts vertically but can be ducted to the rear behind the chimney duct through an outside wall or vertically up through the ceiling to the roof. A short straight duct run will produce the most air flow. Length and elbows will reduce the efficiency of the rangehood.

2. Install a roof or wall cap. Connect a 150mm round duct to the cap and work backwards toward the rangehood. Ensure joints are completely sealed with duct tape.

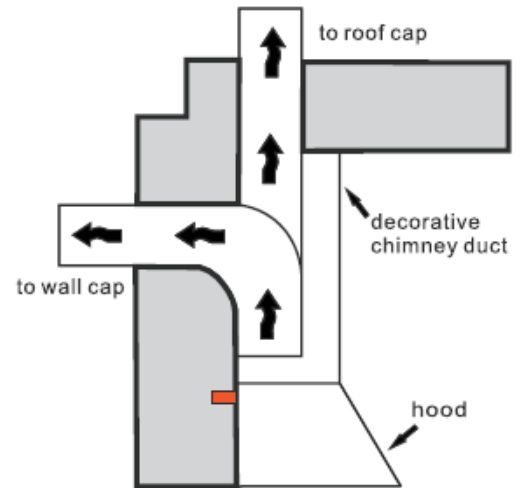

Fixing to the Wall

1. Before mounting the rangehood, plug in and test all functions for proper operation.

2. Removed the filters from the bottom of the rangehood to prevent damage during the installation.

3. With assistance, hold the rangehood temporarily in position ensuring the bottom is above the minimum clearance for the cooking surface. Mark on the wall the holes for the two mounting screws.

4. Drill the holes (A) at the distances indicated. Use the appropriate screws and screw anchors for your wall type (e.g. reinforced concrete, drywall, etc.). If necessary, prepare back wall with cross framing for secure installation.

5. Mount the rangehood on the wall screws. Align it in a horizontal position relative to cabinets. When the rangehood has been adjusted, secure unit by tightening screws (A).

6. Connect a 150mm smooth rigid duct tube (not included) to the exhaust piece using duct tape on all seals. (C)

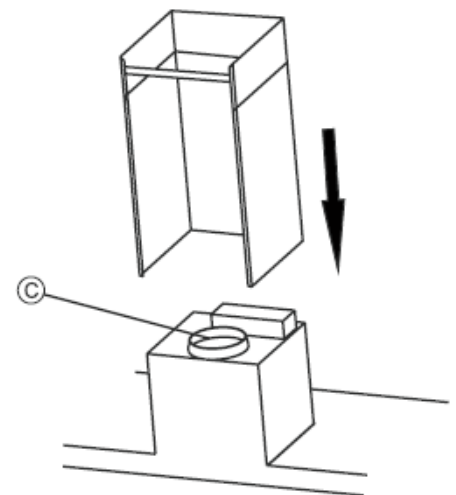
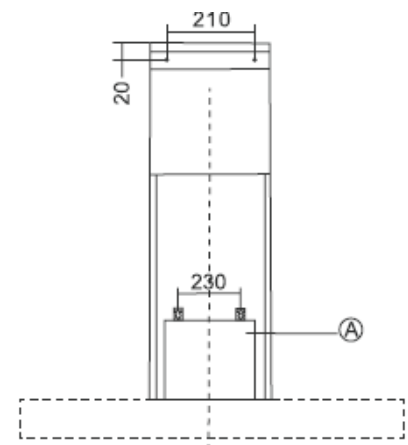

Fixing the Decorative Chimney Flue

1. Carefully loosen but do not separate the telescopic chimney duct pieces.

2. Arrange the electrical power supply within the dimensions of the decorative chimney duct.

3. Adjust the width of the support bracket to match the upper duct. Fix it to the wall using the screws (B) so that it is centered in line with your rangehood and at a distance from the ceiling indicated.

Installation Guidelines

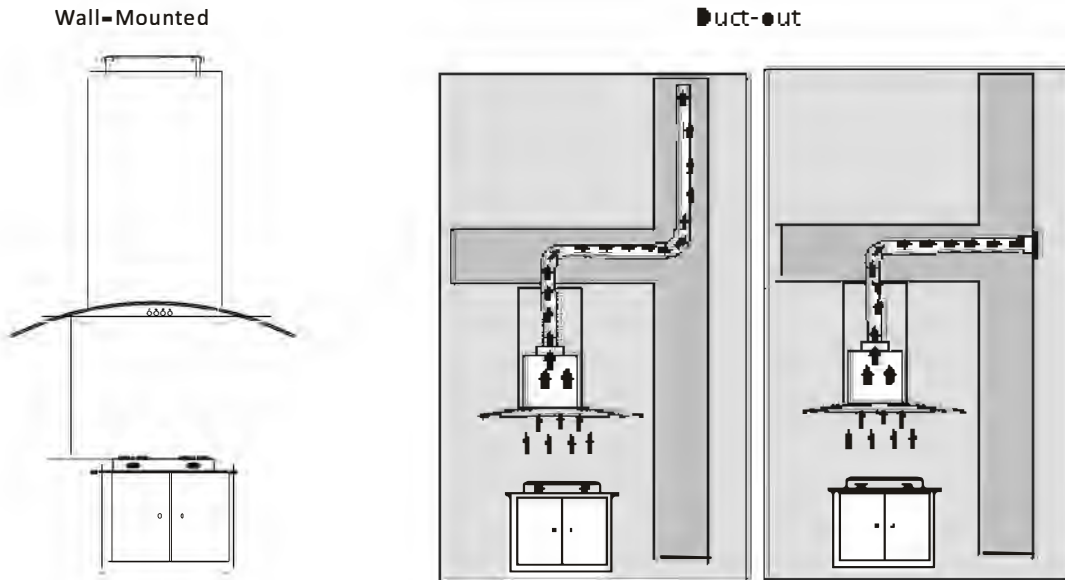

Note: The safety gap between the rangehood and the hob below must comply with the recommendations of the hob manufacturer. In case of no instructions, a minimum distance of 650mm (or other minimum distance as may be specified by AS/ NZS 5601 and interpreted by a certified installer) should apply.

Note: The above installation images and guidelines are for reference only. If you require information about installers you can find this on the Kleenmaid website (see back cover of this manual).



WARNING: IT MUST BE ENSURED THAT THIS APPLIANCE IS CONNECTED ONLY TO A 230VAC +10%/-6% 50Hz MAINS POWER SUPPLY WHICH CONTINUOUSLY COMPLIES WITH THE RELEVANT AUSTRALIAN STANDARD. FAILURE TO DO SO MAY SERIOUSLY DAMAGE THE APPLIANCE AND ANY SUCH DAMAGE IS NOT COVERED BY THE MANUFACTURER'S WARRANTY.



Leveling Device

When mounting rangehood on the wall, the level can be adjusted by turning the two screws on the motor housing.

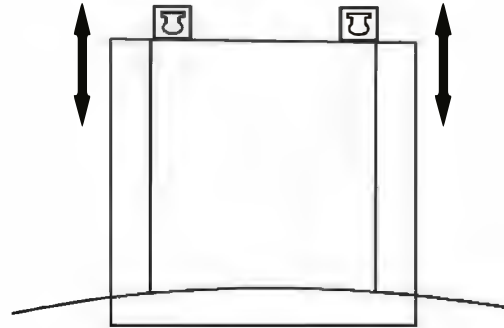
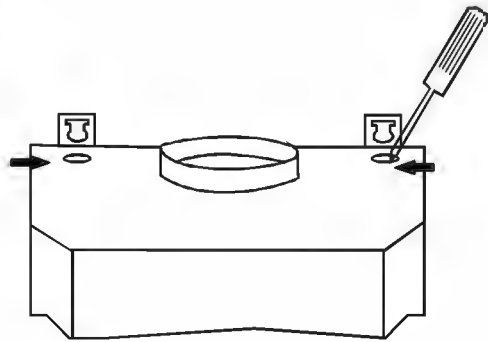

Installation Alternatives

The rangehood can be installed in the following ways:

Circulating indoor air (A)

Outdoor venting (B)

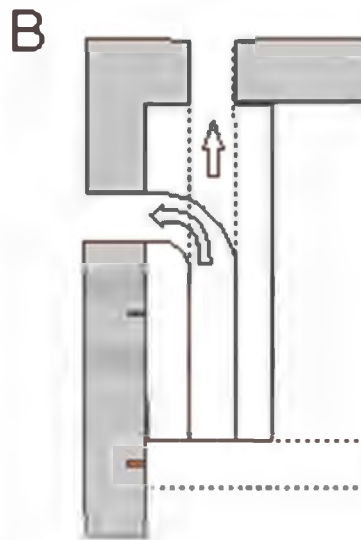
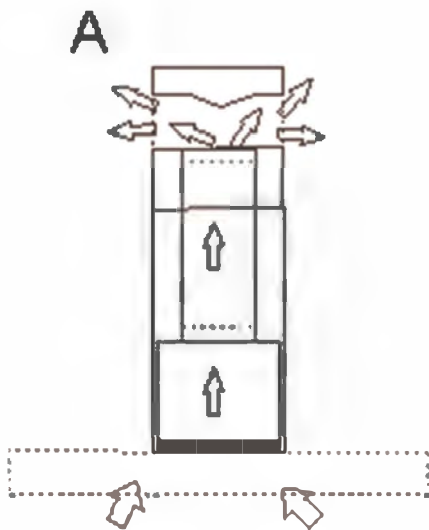

REMEMBER!

- If a two-part connection tube is used, the lower section must sit outside the upper section.
- Do not connect the rangehood exhaust to a duct used to circulate hot air or vent steam from another appliance.
- Always use protective gloves when installing the appliance!

USE AND CARE INSTRUCTIONS

Operations

- 1. For optimum performance in removing cooking odours, it is recommended that you turn on your rangehood prior to cooking and leave it operating for 15 minutes after cooking.**
- 2. Clean the surfaces of the rangehood regularly using a non-abrasive detergent.**
- 3. The anti-grease filters capture the grease particles suspended in the air. They will accumulate grease and dirt depending on the frequency of the use of your cook top.**
- 4. In order to prevent a fire hazard, it is recommended that you clean the stainless steel grease filter at least every 2 months**

Warning:

- Do not attempt to remove the filters while the rangehood is operating.**
- Disconnect the electrical plug prior to any maintenance.**
- This appliance is not intended for use by persons (including children) with reduced physical, sensory or mental capabilities, or lack of experience and knowledge, unless they have been given supervision or instruction concerning use of the appliance by a person responsible for their well being.**
- There should be adequate ventilation in the room when the rangehood is used at the same time as other fuel burning appliances.**

Description of Control

Description of Symbols:

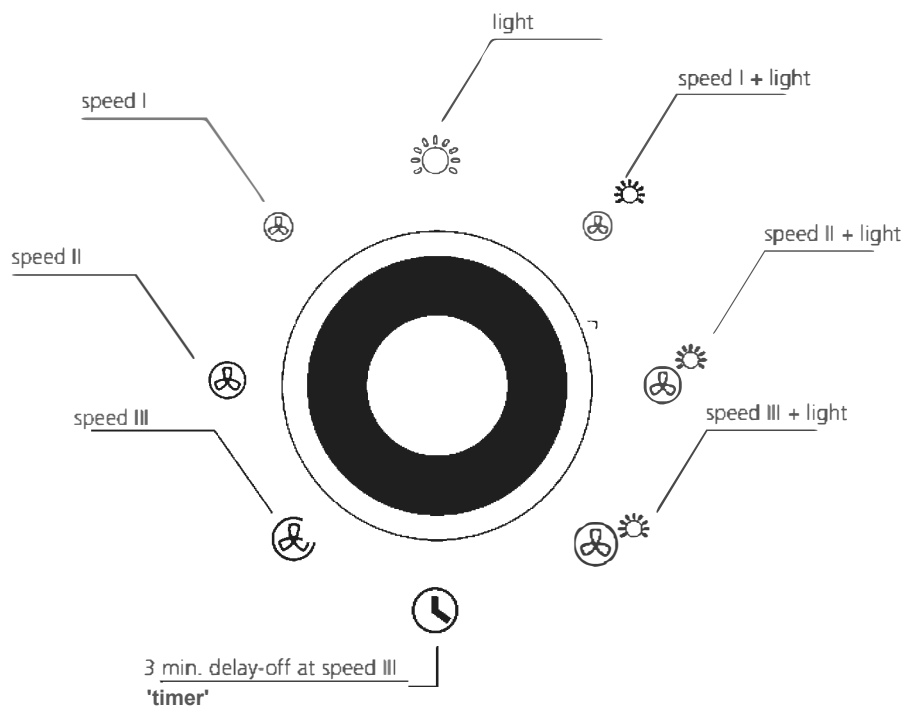

Using the dial control:

- Push the rotary dial and the LED lights will illuminate.
- Turn the rotary switch clockwise or counter-clockwise, stopping the indicating light at the setting you want to select. The rangehood will select that setting after the indicating light illuminates twice.
- Push the rotary switch again at any setting to switch the rangehood off.
- When the indicator light stops at the 'timer' setting, the rangehood will be functioning at speed III and then automatically switch off after 3 min.

MAINTENANCE AND CLEANING

Regular maintenance is required to ensure that the rangehood functions properly. This is especially true of the grease and charcoal filters. Clean the fan and other surfaces of the rangehood regularly with a cloth dipped in methylated spirits or a non-abrasive liquid cleaner.

Maintenance and Replacement of your Kleenmaid Rangehood Filters

Your Kleenmaid rangehood has one or both the following types of filters:

1. The visible stainless steel grease filter, which is present on every rangehood.

These filters should be removed, cleaned and re-installed at least every three months, and more often if food is regularly fried or grilled. These filters may be cleaned either with a soft bristled brush in warm soapy water, or in a dishwasher (without other items). Ensure that each filter is completely dry before re-installing it into the rangehood.

To prevent the risk of fire and to ensure that the rangehood functions properly, the grease filter must always be cleaned as instructed below when the display indicates the need or at least every two months.

Cleaning the grease filter

- Remove the stainless steel baffle filter from the rangehood and clean it in a solution of water and neutral cleaning liquid. Leave the filter to soak in the solution for a while.
- Rinse thoroughly with hot water and leave the filter to dry.
- The filter can also be cleaned in a dishwasher. NB: If you clean the grease filter in the dishwasher: load only the grease filter and no other items as food particles from dishes can fasten in the filter.

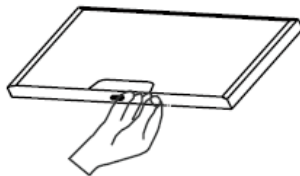

Normally these filters will last the life of the rangehood, however if they are damaged in any way, replacements may be purchased by emailing support@kleenmaid.com.au or calling 02 9310 1207.

WARNING: It must be ensured that the grease filters are correctly installed whenever the rangehood is operating. Failure to do so may damage the rangehood, and such damage will not be covered by the manufacturer's warranty.

2. The internal Kleenmaid Activated Charcoal (or "Carbon") Filter, which should be present on a rangehood which is installed in recirculating mode i.e. not vented outdoors.

These filters are located inside the rangehood and remove cooking odours from the air. These filters cannot be cleaned and will require replacement. The effective life of the filter depends on the type and amount of cooking you do, and how often the grease filter is cleaned. Generally the life of these filters is approximately four - six months. However, always replace the filter when it no longer absorbs odours effectively.

When replacement Activated Charcoal filters are required they may be purchased by emailing support@kleenmaid.com.au or calling 02 9310 1207.

Replacing the charcoal filter

Replace the charcoal filter as follows:

- Remove the grease filter.
- Squeeze the clips on the charcoal filter and pull the charcoal filter back to remove it.
- Install a new charcoal filter and replace the grease filter.

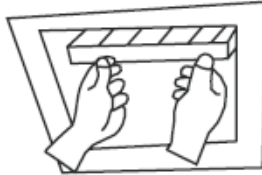

- DO NOT let dirt build up on the rangehood**
- DO NOT use steel wool or steel brushes to clean the rangehood**
- DO NOT leave salt solutions, disinfectants, bleaches or cleaning compounds on the rangehood for any length of time as they may damage the stainless steel. Rinse after use with clean water and wipe dry with a clean cloth.**

Replacing the LED lamps

This rangehood has LED lamps. The illumination is designed for use during cooking and not for prolonged general illumination of your kitchen. Prolonged use of the lights may reduce the life time of the lamps.

WARNING: Do not touch or change lamps while the rangehood is operating. Wait until the lamp has cooled before removing.

Use only the same lamps as in the original specification.

1. With the grease filter removed, from inside the rangehood press the light fixture out of its mounting bracket.
2. Unplug the lamp from the wiring harness. Avoid direct contact between the lens and your hands, then replace with a new one.
3. Push the lamp into its mounting bracket.

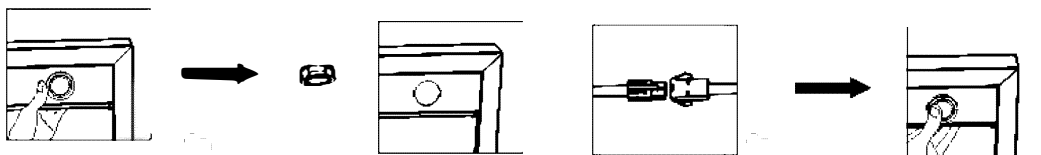

NB: The light is only meant for use during cooking and not for illuminating the surroundings for longer periods. If the light is used for longer periods, this will considerably shorten the burn time of the lamps.

Recycling

This appliance complies with European Community directive 2002/96/EC, Waste Electrical and Electronic Equipment (WEEE). By ensuring that this product is recycled responsibly, the user helps prevent possible negative impact on the environment.

NB:

Dispose of this product responsibly. Irresponsible disposal can result in negative environmental impact or personal injury.



Under no circumstances may this rangehood be disposed of as household waste. It must be taken to a recycling centre for electrical and electronic equipment.

This product must be disposed of in accordance with local legislation. For more information on disposal, recycling and reuse of this product, contact your local authority, your household waste collection service or the store where you purchased the product.

Rangehood Dimensions

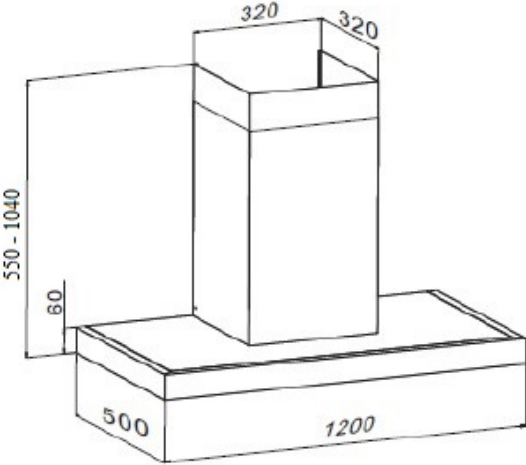
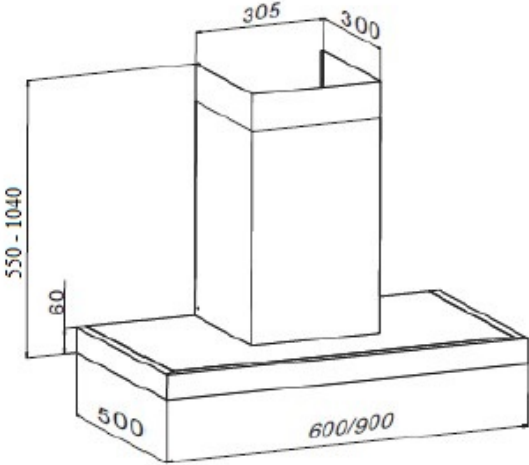

Trouble Shooting Guide

Problem	Possible Reason	Solution
Rangehood doesn't turn on.	No electrical supply.	Check the plug is connected.
	Power cord is damaged	Contact service technician
Poor Airflow	Grease filters clogged	Clean the filters and replace when dry
	Charcoal filters clogged. Re-circulating mode only.	Replace the charcoal filters
Hood is vibrating	Hood is not secured in place	Check the installation of hood. Tighten mounting screws.
Motor running but no air flow	Butterfly valve jammed.	Contact service technician
Motor stops after a few minutes	High temperature safety device activated.	The kitchen is not sufficiently ventilated.
	The hood is installed too near the cooking surface.	Check recommended gap between r /hood and hob
Strong cooking smell.	Fan speed too low	Use one of the higher speed settings.
	Charcoal filters not installed.	In recirculating mode, charcoal filters must be installed.
Oil dripping onto stove.	Grease filter saturated	Wash the grease filters
Whirring sound	Something in contact with fan blade	Contact service technician
Lights are working but fan isn't		Contact service technician
Fan is working but lights are not		Contact service technician

If the appliance fails to operate correctly during the warranty period please visit our website to request a service (see back cover of this manual for details). When booking a service please provide your Model No and the individual Serial Number of your appliance. If you no longer have documentation showing the serial number of your rangehood this is available on the appliance rating plate. Remove the rightmost of the three grease filters in order to see the rating label with your serial number. See instructions for Maintenance and Cleaning on page 12.

KLEENMAID WARRANTY

TERMS AND CONDITIONS

1. Compass Capital Services Pty Ltd ABN 96 138 214 525 trading as Kleenmaid will provide parts and labour to you the customer as set out herein.
2. Kleenmaid's Products come with guarantees that cannot be excluded under the Australian Consumer Law. You are entitled to a replacement or refund for a major failure and for compensation for any other reasonably foreseeable loss or damage. You are also entitled to have the goods repaired or replaced if the goods fail to be of acceptable quality and the failure does not amount to a major failure.
3. The benefits given to you under this Kleenmaid Warranty are in addition to other rights and remedies to which you may be entitled under the Australian Consumer Law in relation to the Product to which this Kleenmaid Warranty relates. Subject to the conditions below, the Product is warranted by Kleenmaid and/or its agents to be free from defects in materials and workmanship for the Warranty Period for normal Domestic Use.
4. Product Identification: -
 - a. Kleenmaid reserves the right to reject claims for any services or work where you cannot produce for verification the serial number and a proof of purchase for the Product (including but not limited to the original invoice).
 - b. this Kleenmaid Warranty will be voided if the serial number for the Product cannot be verified. This is not intended to exclude, restrict or modify any right or remedy to which you may otherwise be entitled under the consumer guarantee provisions of the Australian Consumer Law.
 - c. in the event that a request for repair is made against this Kleenmaid Warranty where the serial number for the Product cannot be verified or you cannot produce for verification a proof of purchase for the Product (including but not limited to the original invoice), the repairer will not carry out any repairs on the Product and you will be charged a service call-out fee.
5. What is covered by this Kleenmaid Warranty: -
 - a. the Product is covered for faulty workmanship or parts that have failed under normal Domestic Use.
 - b. Kleenmaid and/or its agents will determine by objective testing if there are any defects in the Product and/or faulty workmanship.
 - c. this Kleenmaid Warranty is only applicable if repairs on Products are carried out within Mainland Australia.
 - d. this Kleenmaid Warranty: -
 - i. covers a Product purchased as new, manufactured for use in Mainland Australia;
 - ii. commences from the date of delivery of the Product;
 - iii. provides for the labour and replacement parts necessary to maintain the Product in good operating condition as specified in this Kleenmaid Warranty, however, if repair is needed because of Product failure during normal Domestic Use, Kleenmaid has the option to repair or replace the defective Product or part of the Product with a product or part of like kind and quality. A replacement part may be new or reconditioned of like kind and quality and may cost less than the original Product purchased and no charges or refunds will be made based on the replacement product or part cost difference; and
 - iv. is only applicable when the Product is used and operated in accordance with the Manufacturer's instructions.
6. What is not Covered by this Kleenmaid Warranty (excluded):-
 - a. any damage or failure to or of the Product or part of the Product:
 - i. due to the Product being inadequately serviced to manufacturer's recommendations;
 - ii. resulting from environmental conditions including and not limited to dirt, dust, rodents, insects, rust, corrosion, salt built-up, of or in any part of the Product;
 - iii. resulting from excessive use but fair wear and tear is excepted;
 - iv. resulting from poor installation including and not limited to positioning and externally fitted equipment such as plumbing and drainage, cabling, antennae or due to incompatibility of connected equipment;
 - v. caused by overheating as a result of sitting or positioning of the Product, where there is no provision for adequate ventilation or adequate protection from excessive dust;
 - vi. if the Product has been dismantled, repaired or serviced by any person other than someone authorised by Kleenmaid or its agents or representatives;
 - vii. caused by power surges or spikes, including and not limited to, mains power and telecommunications connections, or to other unspecified sources, incorrect power current, voltage fluctuation, amperage fluctuation, rust or corrosion;
 - viii. if the Product is dropped, collision of the Product with another object, use for which the Product is not designed, damage to the Product caused by your own negligence, accidental or deliberate misuse of the Product by you, theft, abuse, vandalism, flood, fire, earthquake, electrical storms or any other act of God or any war related events; or
 - ix. due to the introduction of abnormal heat loads to the Product;
 - b. costs of attendance and testing where no fault or defect covered by the terms of this Kleenmaid Warranty is identified in the Product;
 - c. initial setup and installation of the Product;
 - d. normal maintenance costs and costs incurred through the installation of items listed as requiring periodic replacement;
 - e. Products with removed or altered serial numbers;
 - f. broken or cracked glass other than transport damage to the initial point of delivery;
 - g. consumables such as but not limited to bulbs/globes, seals, filters, batteries and remote controls;
 - h. removal and reinstallation of an internal component not performed by an authorised Kleenmaid agent or representative or authorised service centre;
 - i. cosmetic or structural items; or
 - j. any failures due to interference from or with other products and/or sources.
7. This Kleenmaid Warranty ceases if: -
 - a. the Product ceases to carry the original manufacturer's serial number or is sold at an auction;
 - b. the Product is rented; or
 - c. there is failure to pay monies owing on invoices as a result of non-warranty work being carried out at the request of the end user as per point 16 below.
8. Neither Kleenmaid nor its representatives provide loan equipment under the terms of this Kleenmaid Warranty.
9. Any unauthorised access to the internal hardware of the Product will void this Kleenmaid Warranty.

10. Repair Notice: Products presented for repair may be replaced by refurbished Products of the same type rather than being repaired. Refurbished parts may be used to repair the Products.
11. Replacement items are "like for like" and is not "new for old" and does not indicate in any way that a faulty Product will be replaced with a new part or unit. "Like for like" may either be a quality checked, refurbished or reconditioned unit of the same or later batch of model/size/specifications
12. The cost of making a claim under this Kleenmaid Warranty is not covered by Kleenmaid, including any costs of transportation or travel expenses between your home and your nearest authorised service agent.
13. Kleenmaid accepts no liability for items that are lost, damaged, or stolen as a result of freight, transport or storage. If you are required to transport the Product to an authorised service centre, you must ensure that it is securely packed and insured.
14. On Public Holidays or other periods when regular business and wholesale operations are temporarily ceased, repairer availability and warranty response times may extend beyond the standard response times due to the unavailability of repairers and parts.
15. For any repair performed on a Product under this Kleenmaid Warranty where no fault can be found, or the item is deemed by Kleenmaid or an authorised agent, to be not faulty under this Kleenmaid Warranty, or the repair or fault is not covered under this Kleenmaid Warranty, a 'No Fault Found' fee is payable by you. Kleenmaid will advise you of this cost and seek your agreement to pay such costs before commencing such repairs.
16. Any repairs or services required that are outside the terms and conditions of this Kleenmaid Warranty can be carried out at your request at your cost (including where the Product has not been installed or set up correctly). Kleenmaid will always advise you of this cost and seek your agreement to pay such costs before commencing such repairs. A credit card may be required prior to the commencement of such services.
17. Extra charges will be payable by the customer should the Product not be readily accessible without special equipment, such as but not limited to cranes and lifts or should the Product be installed in a position that service access is blocked and/or repair work is not possible without uninstalling the Product to gain access.
18. You, the customer, may be entitled to purchase an extended warranty in respect of the Product. Any extended warranty will not be issued by Kleenmaid but by a third party. Any extended warranty services will be provided directly by the third party as principal and not as agent for Kleenmaid, under their extended warranty terms and conditions and not under this Kleenmaid Warranty.
19. To make a claim under this Kleenmaid Warranty, please have your proof of purchase and the serial number of the Product ready and call (02) 9310 1207 during business hours.
20. This Kleenmaid Warranty is given by:
 - Name: Compass Capital Services Pty Ltd ABN 96 138 214 525 trading as Kleenmaid
 - Business address: Level 2, Suite 3, 204 Botany Rd, Alexandria NSW Australia 2015
 - Telephone: (02) 9310 1207
21. Definitions:
 - a. **Australian Consumer Law** means the *Competition and Consumer Act 2010* (Cth).
 - b. **Domestic Use** means use of the Product for personal, domestic or household purposes.
 - c. **Kleenmaid** means Compass Capital Services Pty Ltd ABN 96 138 214 525 trading as Kleenmaid.
 - d. **Mainland Australia** means the following States and Territories of Australia: New South Wales, Victoria, South Australia, Western Australia, Queensland, Tasmania, Northern Territory, Australian Capital Territory.
 - e. **Product** means the appliance sold by Kleenmaid to you as evidenced by the original purchase invoice.
 - f. **Warranty Period** means the period of 60 months for domestic use, 12 months for non-domestic use or such alternative period as may be specified.

UPDATE NOTICE: This Kleenmaid Warranty is current as at 1 January 2019 but is subject to variation from time to time. For the latest version of the Kleenmaid Warranty, please see our website <https://kleenmaid.com.au/warranty/> or phone us on (02) 9310 1207.

This page has been intentionally left blank.

Other products available in the Kleenmaid range of appliances

- | Washing machines
- | Clothes dryers
- | Dishwashers
- | Ovens
- | Cooktops
- | Steam ovens
- | Microwave ovens
- | Built in espresso coffee machines
- | Rangehoods
- | Freestanding ovens
- | Refrigerators & Freezers
- | Beverage Serving Cabinets
- | Water Dispensers
- | Vacuum Cleaners

To register your warranty or make a warranty claim, scan this QR code:



Compass Capital Services Pty Limited
trading as Kleenmaid
ABN 96138214525

Level 2, 204 Botany Road Alexandria
NSW 2015



Register your Kleenmaid
Appliances Warranty
www.kleenmaidwarranty.com.au



Request a Warranty Service
www.kleenmaidwarranty.com.au

E: support@kleenmaid.com.au
Please download the current User Manual for this
appliance at www.kleenmaid.com.au

 **kleenmaid**

RHSC61, RHSC91 & RHSC121 V6