

# Contents

EN

<b>1</b>	<b>Instructions</b>	<b>4</b>
1.1	General safety instructions	4
1.2	Manufacturer liability	7
1.3	Appliance purpose	7
1.4	Disposal	8
1.5	Identification plate	8
1.6	This user manual	8
1.7	How to read the user manual	9
<b>2</b>	<b>Description</b>	<b>10</b>
2.1	General Description	10
2.2	Symbols	11
<b>3</b>	<b>Use</b>	<b>12</b>
3.1	Instructions	12
3.2	First use	13
3.3	Using the cooktop	13
<b>4</b>	<b>Cleaning and maintenance</b>	<b>16</b>
4.1	Instructions	16
4.2	Cleaning the appliance	16
<b>5</b>	<b>Installation</b>	<b>18</b>
5.1	Clearances above and around domestic appliances	18
5.2	Safety instructions	19
5.3	Section cut from the work surface	20
5.4	Mounting	22
5.5	Fixing using brackets	23
5.6	Gas connection	24
5.7	Adaptation to different types of gas	27
5.8	Electrical connection	31
5.9	Instructions for the installer	32

These instructions apply only to the destination countries listed on the appliance's data plate.

This is a class 3 built-in hob.

We advise you to read this manual carefully, as it contains all the instructions for maintaining the appliance's aesthetic and functional qualities.

For further information on the product: [www.smeg.com](http://www.smeg.com) 02 8667 4833



# Instructions

## 1 Instructions

### 1.1 General safety instructions

#### Risk of personal injury

- During use the appliance becomes hot. Care should be taken to avoid touching heating elements inside the oven.
- **WARNING** - Accessible parts will become hot when in use. To avoid burns young children should be kept away.
- Never try to put out a fire or flames with water: turn off the appliance and smother the flames with a fire blanket or other appropriate cover.
- The appliance is not intended for use by persons (including children) with reduced physical, sensory or mental capabilities, or lack of experience and knowledge, unless they have been given supervised or instruction concerning use of the appliance by a responsible person for their safety.
- Young children should be supervised to ensure that they do not play with the appliance.
- Keep children under eight years of age at a safe distance if they are not constantly supervised.
- Do not allow children younger than 8 years old to come near the appliance when in operation.
- Cleaning and maintenance must not be carried out by unsupervised children.
- Make sure that the flame-spreader crowns are correctly positioned in their housings with their respective burner caps.
- Be aware of how rapidly the cooking zones heat up. Do not place empty pans on the heat. Danger of overheating.
- Fats and oils can catch fire if they overheat. Do not leave the appliance unattended while preparing foods containing oils or fats. If fats or oils catch fire, never put water on them. Place the lid on the pan and turn off the relevant cooking zone.
- **Warning** – Unattended cooking on a hob with fat or oil can be dangerous and may result in a fire.
- **CAUTION** – The cooking process has to be supervised. A short term cooking process has to be supervised continuously.
- When in use, do not place metal objects, such as dishes or cutlery, on the surface of the cooktop as they may overheat.
- Do not insert pointed metal objects (cutlery or utensils) into the slots in the appliance.



- DO NOT USE OR STORE FLAMMABLE MATERIALS NEAR THE APPLIANCE.
- NEVER USE AEROSOL CANS NEAR THE APPLIANCE WHILE IT IS IN OPERATION.
- Switch the appliance off immediately after use.
- DO NOT MODIFY THIS APPLIANCE.
- Before carrying out any work on the appliance (installation, maintenance, positioning or moving), wear personal protective equipment.
- Before carrying out any work on the appliance, disconnect the mains power supply.
- Have authorised persons carry out installation and assistance interventions according to the standards in force.
- Do not try to repair the appliance yourself or without the intervention of authorised persons.
- Do not pull the cable to remove the plug.
- If the power supply cable is damaged, contact technical support immediately and they will replace it.

## Risk of damaging the appliance

- Use wooden or plastic utensils.
- Do not seat on the appliance.
- Do not use steam jets to clean the appliance.
- Do not obstruct ventilation openings and heat dispersal slots.
- Never leave the appliance unattended during cooking operations in which fats or oils could be released that could overheat and catch fire. Be very careful.
- Danger of fire – Do not store items on the cooking surface.
- DO NOT USE THE APPLIANCE AS A SPACE HEATER.
- DO NOT PLACE ARTICLES ON OR AGAINST THIS APPLIANCE.
- NOT SUITABLE FOR USE WITH AFTERMARKET LIDS OR COVERS.
- Do not spray any spray products near the oven.
- Do not use plastic kitchenware or containers when cooking food.
- All cookware must have smooth, flat bottoms.
- If any liquid does boil over or spill, remove the excess from the cooktop.



## Instructions

- Take care not to spill acidic substances such as lemon juice or vinegar onto the cooktop.
- Do not put empty pans or frying pans on switched on cooking zones.
- Do not use a steam cleaner to clean this appliance.
- Do not use harsh abrasive cleaners or sharp metal scrapers to clean glass since they can scratch the surface, which may result in shattering of the glass.
- Do not use cleaning products containing chlorine, ammonia or bleach on steel parts or parts with metallic surface finishes (e.g. anodizing, nickel- or chromium-plating).
- Do not wash the removable components such as the cooktop pan stands, flame-spreader crowns and burner caps in a dishwasher.
- Do not wash removable parts such as the cooktop grids, flame-spreader crowns and burner caps in the dishwasher.
- Position the appliance into the cabinet cutout with the help of a second person.
- To prevent overheating, the appliance must not be installed behind a decorative door or a panel.
- The gas connection should be carried out by authorised persons.
- Installation with flexible hose must be carried out so that the length of the piping does not exceed 2 metres when fully extended as regards flexible steel hoses and 1.5 metres in case of rubber hoses.
- The hoses should not come into contact with moving parts and should not be crushed in any way.
- If required, use a pressure regulator that complies with current regulations.
- After carrying out any operation, check that the tightening torque of gas connections is between 10 Nm and 15 Nm.
- At the end of the installation, check for any leaks with a soapy solution, never with a flame.
- Have the electrical connection performed by authorised persons.
- The appliance must be connected to earth in compliance with electrical system safety standards.

### Installation

- **THIS APPLIANCE MUST NOT BE INSTALLED IN BOATS OR CARAVANS.**
- The appliance must not be installed on a stand.



- Use cables withstanding a temperature of at least 90°C.
- The tightening torque of the screws of the terminal supply wires must be 1.5 - 2 Nm.
- Before installation, make sure that the local gas supply (gas type and pressure) and the settings of the domestic appliance are compatible.
- The settings for this domestic appliance are shown on the gas setting label.
- This domestic appliance is not connected to a device for extracting combustion products. It must be installed and connected in accordance with current installation regulations. Pay particular attention to the relevant requirements regarding ventilation.
- If the electrical supply is restricted, means of all-pole disconnection must be accessible and incorporated in the fixed wiring in accordance with the wiring rules.

## For this appliance

- Do not obstruct ventilation openings and heat dispersal slots.
- Do not insert pointed metal objects (cutlery or utensils) into the slots in the appliance.

- This appliance is not intended to be operated by means of external timer or separate remote control system.

## 1.2 Manufacturer liability

The manufacturer declines all liability for damage to persons or property caused by:

- use of the appliance other than the one envisaged,
- failure to comply with the instructions in the user manual,
- tampering with any part of the appliance,
- use of non-original spare parts.

## 1.3 Appliance purpose

- This appliance is intended for cooking food in the home environment. Every other use is considered inappropriate.
- The appliance is not designed to operate with external timers or with remote-control systems.

## 1.4 Disposal



This appliance conforms to the WEEE European directive (2012/19/EU) and must be disposed of separately from other waste at the end of its service life.



## Instructions

The appliance does not contain substances in quantities sufficient to be considered hazardous to health and the environment, in accordance with current European directives. To dispose of the appliance:



### Power voltage Danger of electrocution

- Disconnect the mains power supply.
- Unplug the appliance.
- Cut the power supply cable and remove it along with the plug.
- Deliver the appliance to the appropriate recycling centre for electrical and electronic equipment waste, or return it to the retailer when purchasing an equivalent product, on a one for one basis.

Our appliances are packaged in non-polluting and recyclable materials.

- Deliver the packing materials to the appropriate recycling centre.



### Plastic packaging Danger of suffocation

- Do not leave the packaging or any part of it unattended.
- Do not let children play with the packaging plastic bags.

### 1.5 Identification plate

The identification plate bears the technical data, serial number and brand name of the appliance. Do not remove the identification plate for any reason.

### 1.6 This user manual

This user manual is an integral part of the appliance and must therefore be kept in its entirety and within the user's reach for the whole working life of the appliance. Read this user manual carefully before using the appliance.

Place the supplied duplicate data plate to a suitable adjacent surface or within the instruction manual for future reference.



## 1.7 How to read the user manual

This user manual uses the following reading conventions:

### Instructions



General information on this user manual, on safety and final disposal.

### Description



Description of the appliance and its accessories.

### Use



Information on the use of the appliance and its accessories.

### Cleaning and maintenance



Information for proper cleaning and maintenance of the appliance.

### Installation



Information for the qualified technician: Installation, operation and inspection.



Safety instructions



Information



Advice

1. Sequence of instructions for use.

- Standalone instruction.



# Description

## 2 Description

### 2.1 General Description

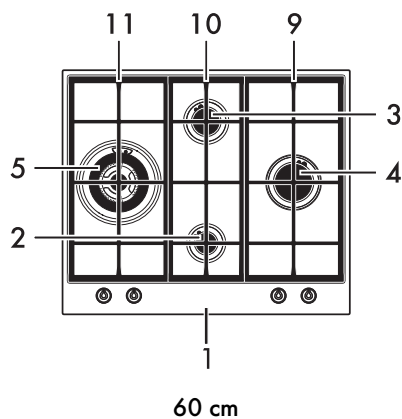

60 cm

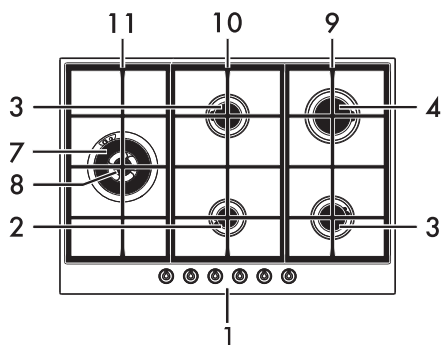

70 cm side UR

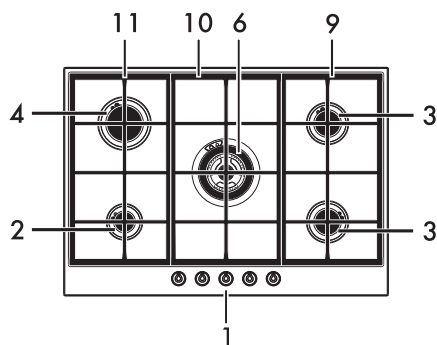

70 cm central UR

- 1. Control panel
- 2. Auxiliary burner (AUX)
- 3. Semi-rapid burner (SR)
- 4. Rapid burner reduced (RR)
- 5. Ultra-rapid triple crown burner (UR\*)
- 6. Ultra-rapid triple crown burner (UR)
- 7. Ultra-rapid burner with external crown (UR2 ext.)
- 8. Ultra-rapid burner with internal crown (UR2 int.)
- 9. Right grid
- 10. Central grid
- 11. Left grid









## 2.2 Symbols

### Cooking zones

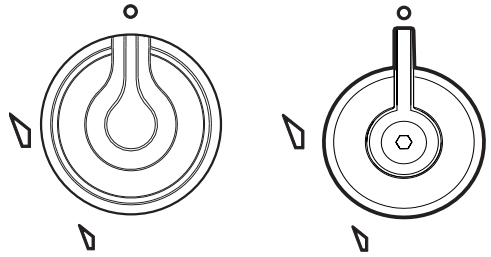
- Front left
- Centre left
- Rear left
- Central
- Rear right
- Central right
- Front right
- Internal lateral
- External lateral

### Burner knobs



For lighting and adjusting the burners. Press and turn the knobs anti-clockwise to  in order to light the relative burners. Turn the knobs to the zone between the maximum  and minimum  setting to adjust the flame. Return the knobs to the position  to turn off the burners.



## 3 Use

### 3.1 Instructions



#### Improper use Danger of burns

- Make sure that the flame-spreader crowns are correctly positioned in their seats with their respective burner caps.
- Oils and fats could catch fire if overheated. Be very careful.
- Do not leave the appliance unattended during cooking operations where fats or oils could be released.
- Do not spray any spray product near the appliance.
- Do not touch the appliance's heating elements when it is running. Leave them to cool before cleaning.
- Keep children under the age of 8 away from the appliance when it is in use.



#### Improper use Risk of damage to surfaces

- Do not use aluminium foil to cover the burners or hob body.
- Cooking vessels or griddle plates should be placed inside the perimeter of the cooktop.
- All pans must have smooth, flat bottoms.
- If any liquid does boil over or spill, remove the excess from the cooktop.
- It is not recommended to use earthenware or steatite (soapstone) pans to cook or heat food.



#### IMPROPER USE RISK OF FIRE OR EXPLOSION

- DO NOT SPRAY AEROSOLS IN THE VICINITY OF THIS APPLIANCE WHILE IT IS IN OPERATION.
- DO NOT USE FLAMMABLE MATERIALS NEAR THIS APPLIANCE.
- DO NOT PLACE ARTICLES ON OR AGAINST THIS APPLIANCE.
- DO NOT MODIFY THIS APPLIANCE.
- DO NOT USE THIS APPLIANCE AS A SPACE HEATER.
- NOT SUITABLE FOR USE WITH AFTERMARKET LIDS OR COVERS.

#### Escaping gas may cause an explosion.

If you smell gas or notice any faults in the gas installation:

- Immediately shut off the gas supply or close the gas cylinder valve.
- Immediately extinguish all naked flames and cigarettes.
- Do not use any light or appliance switches and do not pull any plugs out of sockets. Do not use any telephones or mobile phones within the building.
- Open windows and ventilate the room.
- Call the aftersales service or the gas supplier.

#### Abnormal operation

Any of the following are considered to be abnormal operation and may require service:

- Yellow tipping of the hotplate burner flame.
- Sooting up of cooking utensils.



- Burners not igniting properly.
- Burners failing to remain alight.
- Burners extinguishing whilst in operation.
- Gas valves which are difficult to turn.

In case the appliance fails to operate correctly, contact the Authorised Assistance Centre in your area.

### 3.2 First use

1. Remove any protective film from the outside or inside of the appliance, including accessories.
2. Remove any labels (apart from the technical data plate) from accessories.
3. Remove and wash all the appliance's accessories (see 4 Cleaning and maintenance).

### 3.3 Using the cooktop

All the appliance's control and monitoring devices are located together on the front panel. The burner controlled by each knob is shown next to the knob. The appliance is equipped with an electronic ignition device. Simply press the knob and turn it anti-clockwise to the maximum flame symbol, until the burner ignites. If the burner does not light in the first 15 seconds, turn the knob to  and wait 60 seconds before trying again. After lighting, keep the knob pressed in for a few seconds to allow the thermocouple to heat up. The burner may go out when the knob is released: In this case, the thermocouple has not heated up sufficiently.

Wait a few moments and repeat the operation. Keep the knob pressed in longer.



In case of an accidental switching off, a safety device will be tripped, cutting off the gas supply, even if the gas tap is open. Return the knob to  and wait at least 60 seconds before lighting it again.

### Correct positioning of the flame-spreader crowns and burner caps

Before lighting the cooktop burners, make sure that the flame-spreader crowns are correctly positioned in their housings with their respective burner caps. Make sure that the holes in the burners are aligned with the igniters and thermocouples. Also ensure that the flame-spreader crowns are correctly engaged in the burner holes.

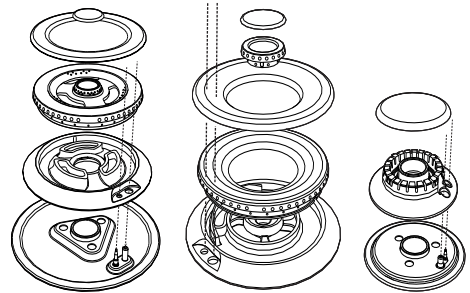



## Use

### Correct positioning of the grids

To install the grids follow the instructions and the following figures.

1. Lay the lateral grids on the cooktop paying attention to position the front teeth facing the knobs.

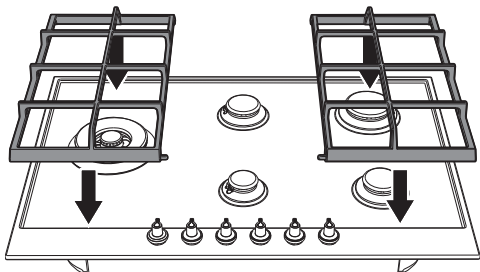

2. Lay the centre grid engaging the notches in the teeth of the lateral grids.

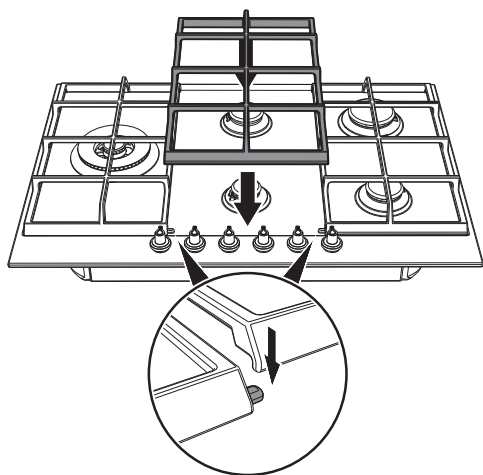

In addition, pay attention to the mark "FRONT" under each grid at the front, as a further help to correctly position the grids on the cooktop.

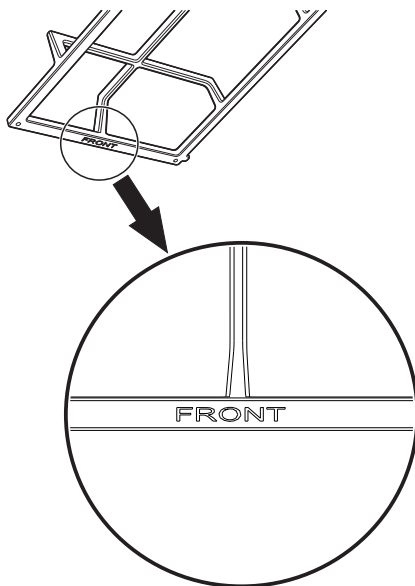

- Position the grids so that the marks "FRONT" are facing the cooktop knobs.



## Practical tips for using the cooktop

For better burner efficiency and to minimise gas consumption, use pans with lids and of suitable size for the burner, so that the flames do not reach up the sides of the pan. Once the contents come to the boil, turn down the flame far enough to ensure that the liquid does not boil over.



Cookware diameters:

- Aux.: 12 - 18 cm.
- Semi rapid: 14 - 24 cm.
- Rapid: 20 - 26 cm.
- Ultra-rapid: 20 - 30 cm.

To prevent burns or damage to the cooktop or the counter top during cooking, all pans or griddles must be placed inside the perimeter of the grids.

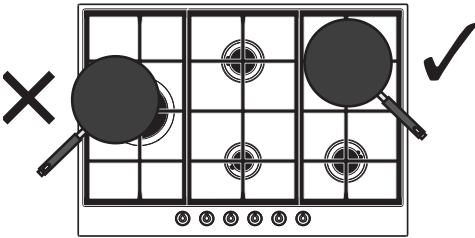



# Cleaning and maintenance

## 4 Cleaning and maintenance

### 4.1 Instructions



**Improper use  
Risk of damage to surfaces**

- Do not use steam jets to clean the appliance.
- Do not use cleaning products containing chlorine, ammonia or bleach on parts made of steel or that have metallic surface finishes (e.g. anodizing, nickel- or chromium-plating).
- If it comes into contact with aggressive detergents, hard water or spills (cooking water, sauces, coffee, etc.), clean immediately after having let the cooktop cool down.
- Do not use rough or abrasive materials or sharp metal scrapers.
- Do not wash the removable components such as the cooktop grids, flame-spreader crowns and burner caps in a dishwasher.

### 4.2 Cleaning the appliance

To keep the surfaces in good condition, they should be cleaned regularly after use. Let them cool first.

#### Ordinary daily cleaning

Always use specific products only that do not contain abrasives or chlorine-based acids.

Pour the product onto a damp cloth and wipe the surface, rinse thoroughly and dry with a soft cloth or a microfibre cloth.

#### Food stains or residues

Do not use steel sponges and sharp scrapers, as they will damage the surfaces.

Use normal, non-abrasive products and a wooden or plastic tool, if necessary. Rinse thoroughly and dry with a soft cloth or a microfibre cloth.



Annual service by an authorised person is recommended, or if any of the following conditions are noticed; incomplete ignition, appreciable yellow tipping, carbon deposition, lifting, floating, lighting back or objectionable odour.



## Cooktop grids

Remove the grids and clean them in lukewarm water and non-abrasive detergent. Make sure to remove any encrustations. Dry them thoroughly and return them to the cooktop.



The continuous contact between the grids and the flame can cause modifications to the enamel over time in those parts exposed to heat. This is a completely natural phenomenon which has no effect on the operation of this component.

## Igniters and thermocouples

For correct operation the igniters and thermocouples must always be perfectly clean. Check them frequently and clean them with a damp cloth if necessary. Remove any dry residues with a wooden toothpick or a needle.

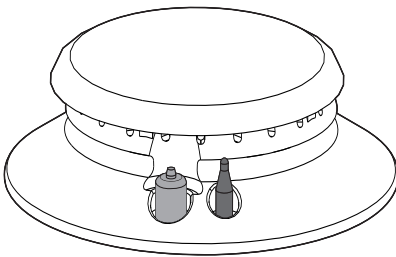

## Flame-spreader crowns and burner caps

For easier cleaning, the flame-spreader crowns and the burner caps can be removed.

Wash them in hot water and non-abrasive detergent. Carefully remove any encrustation, then wait until they are perfectly dry. Refit the flame-spreader crowns making sure that they are correctly positioned in their housings with their respective burner caps.

## Knobs



Do not use aggressive products containing alcohol or products for cleaning steel and glass when cleaning the knobs, as these products could cause permanent damage.

The knobs should be cleaned with a soft cloth dampened with warm water, then dried carefully. They can easily be removed by pulling them upwards.

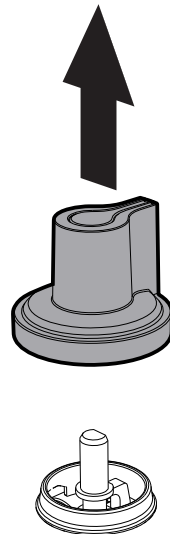



# Installation

## 5 Installation

### 5.1 Minimum clearance to combustible surface

#### Cooktop

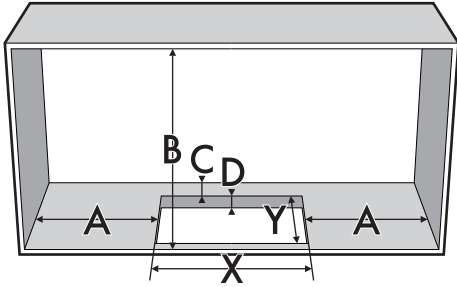

- A** 200mm (Vertical combustible surface)
- B** 600mm (Overhead) measured from the highest part of the highest burner and 750mm for an exhaust fan.
- C** 50mm (non-combustible surface)
- D** 20mm (benchtop)
- X** (width) & **Y** (depth) see appliance dimension within this manual.

Refer to AS/NZS 5601 (Protection of a combustible surface) if the above minimum clearances cannot be achieved.

Maximum height of the top of the pan support with respect to the surface that supports the appliance is 47mm.

The appliance connection point shall be accessible with the appliance installed.

### 5.2 Safety instructions



Heat production during appliance operation  
**Risk of fire**

- Make sure that the cabinet material is heat resistant.
- Check that the cabinet has the required slots.

Veneers, adhesives or plastic coatings on adjacent furniture should be temperature-resistant (>90°C), otherwise they might warp over time.



The minimum clearance between a ventilation hood and the cooking surface must be at least the distance indicated in the ventilation hood installation instructions.

The minimum clearances must also be respected for the edges of the cooktop on the back as indicated in the mounting illustrations.





## 5.3 Section cut from the work surface

**i** The following operation requires building and/or carpentry work and must therefore be carried out by a competent tradesman. Installation can be carried out on various materials such as masonry, metal, solid wood or plastic laminated wood as long as they are heat resistant (>90°C).

Create an opening with the dimensions shown in the figure in the work surface of the piece of furniture.

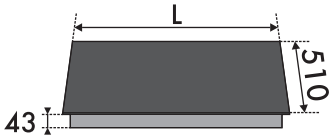

L (cm)	X (mm)	Y (mm)
60 - 70 <b>C</b>	555 - 560	478 - 482
70 <b>L</b>	655 - 660	478 ÷ 482

**C:** 70 cm models with central UR.

**L:** 70 cm models with side UR

Overall dimensions: gas and electrical connection location (measures in mm)

60 cm models:

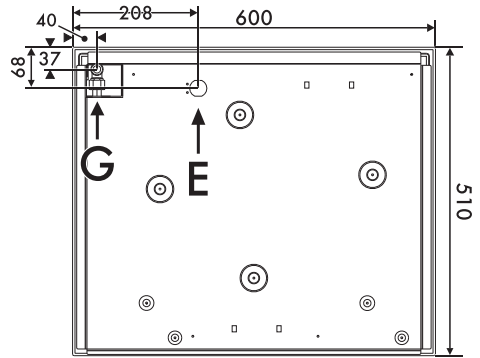

View from the bottom

**G** Gas connection

**E** Electrical connection

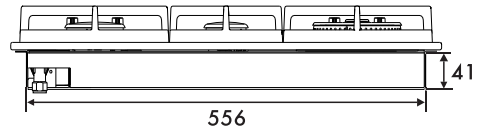

Rear view



Right view



# Installation

70 cm models with side UR:

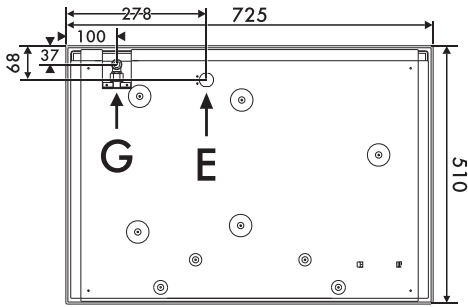

**G** Gas connection

**E** Electrical connection

**View from the bottom**



**Rear view**

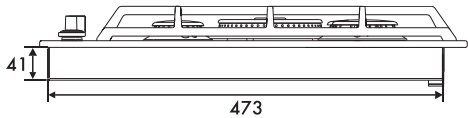

**Right view**

70 cm models with central UR:

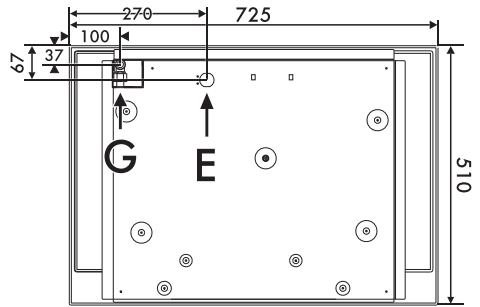

**View from the bottom**

**G** Gas connection

**E** Electrical connection

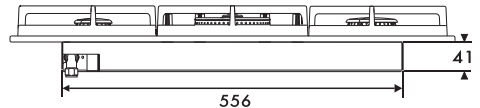

**Rear view**

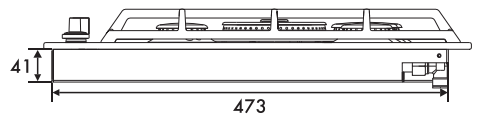

**Right view**



## 5.4 Mounting

### Over built-in oven unit

The clearance between the cooktop and the kitchen furniture or other installed appliances must be enough to ensure sufficient ventilation and air discharge.

If installed above an oven, a space must be left between the bottom of the cooktop and the top of the appliance installed below.

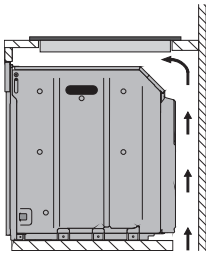

opens on bottom

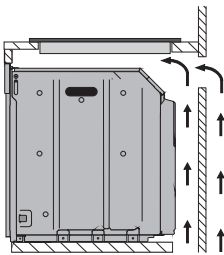

opens on bottom and on rear



If installed on top of an oven, the latter must be equipped with a cooling fan.

### Over empty kitchen unit or drawers

If there are other pieces of furniture (lateral walls, drawers, etc.), dishwashers or fridges under the cooktop, a double-layer wooden base must be installed at least **10 mm** from the bottom of the cooktop to avoid any accidental contact. It must only be possible to remove the double-layer base using suitable equipment.

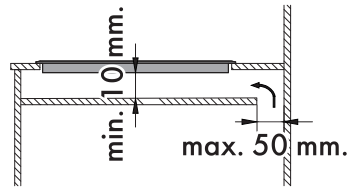
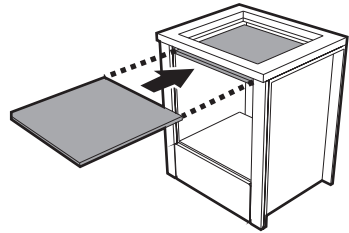

opens on bottom

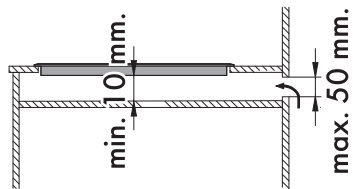

opens on rear



Failure to install the double-layer wooden base exposes the user to possible accidental contact with sharp or hot parts.



# Installation

## Cooktop seal

To prevent leakage of liquid between the frame of the cooktop and the work surface, put the insulating seal provided in position before assembly.

1. Apply the seal along the outer edge of the appliance surface.

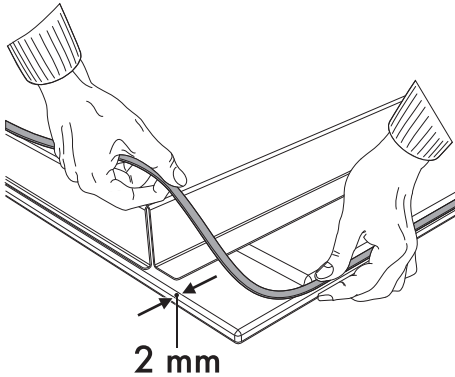

2. Lay the appliance in the hole on the work top (chapter 5.2 "Section cut from the work surface").



Do not use silicone to secure the cooktop. This would make it impossible to remove, if necessary, without damaging it. Use the insulating seal provided.

## 5.5 Fixing using brackets

The figures below show the exact holes to be used to correctly attach the cooktop to the work surface with brackets.

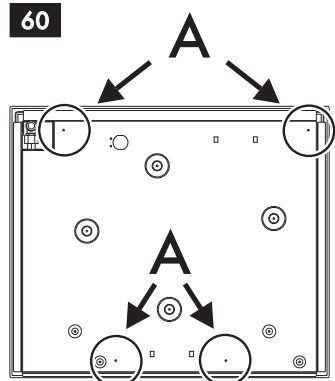
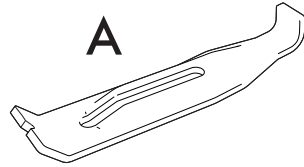

60 cm models

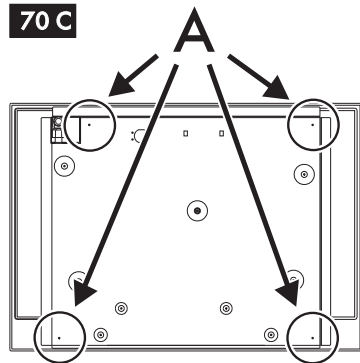

70 cm models with central UR



70 L

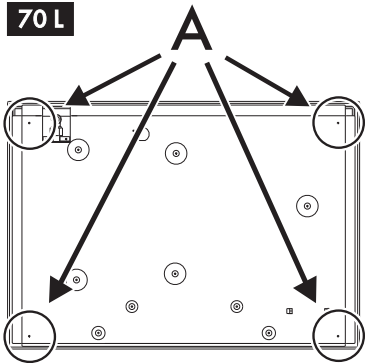

### 70 cm models with lateral UR

Screw the fixing brackets **(A)** into the holes on the sides of the bottom casing to properly fasten the cooktop to the structure.

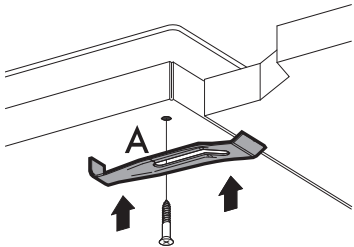

## 5.6 Gas connection



Gas leak  
Danger of explosion

- After carrying out any operation, check that the tightening torque of gas connections is between 10 Nm and 15 Nm.
- At the end of the installation, check for any leaks with a soapy solution, never with a flame.
- Installation with flexible hose must be carried out so that the length of the piping does not exceed 1,2 metres when fully extended; make sure that the hoses do not come into contact with moving parts and that they are not crushed in any way.
- The hoses should not come into contact with moving parts and should not be crushed in any way.
- The settings for this domestic appliance are shown on the gas setting label.

Carefully screw the connector **3** to the appliance's gas connector **1** (1/2" thread ISO 228-1), placing the supplied seal **2** between them.

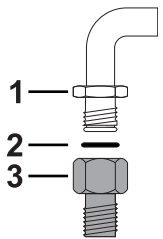



# Installation

This appliance must be installed by an authorised person in accordance with the instruction manual, AS/NZS 5601 - Gas installations (installation and pipe sizing), local gas fitting regulations, local water regulations, local electric regulations, local health regulations, Building Code of Australia and any government authority.

This appliance is suitable for connection with rigid pipe or flexible hose. The isolating manual shut-off valve connection point must be accessible when the appliance is installed.

Flexible hose assembly must be certified to AS/NZS 1869 class B or D, be of appropriate internal diameter for the total gas consumption (10mm), be kept as short as possible (not exceeding 1200mm), must not be in contact with the floor or any hot surface. The hose assembly must not be subject to strain, abrasion, kinking, deformation, contact with any other appliance or accidental contact with oven flue outlet of an under bench oven.

**Natural Gas:** the pressure regulator must be fitted to the appliance inlet connection. Gas pressure must be adjusted to 1.0 kPa when approximately 50% of the burners are on high flame, the appliance test point is located on the regulator.

**ULPG:** the supplied test point adaptor must be fitted to the appliance inlet connection. Gas pressure must be checked to 2.75 kPa when approximately 50% of the burners are on high flame.

Gas leakage and operation of the appliance must be tested by the installer before leaving.

Check burner flames are blue in colour, stable and completely ignite at both high and low flame settings with no appreciable yellow tipping, carbon deposition, lifting, floating, lighting back or objectionable odour.

Test burners individually and in combination, when satisfied with the operation of the cooker, please instruct the user on the correct method of operation.

## Room ventilation

The room containing the appliance should have a permanent air supply in accordance with the standards in force. The room where the appliance is installed must have enough air flow needed for the regular combustion of gas and the necessary air change in the room itself. The cooktop shall be installed in rooms with natural ventilation, as required by Standards regulations AS/NZS5601.

## Combustion gas discharge

Combustion gases may be discharged by means of hoods connected to a flue with reliable natural draught, or a fan extraction system. An effective extraction system requires careful design by an authorised specialist, and must comply with the regulation distances and positions. After installation, the engineer must issue a certificate of compliance.



## Extraction of the combustion products



This domestic appliance is not connected to a device for extracting combustion products. It must be installed and connected in accordance with current installation regulations. Pay particular attention to the relevant requirements regarding ventilation.

The combustion products may be extracted by means of hoods connected to a natural draught chimney whose efficiency is certain or via forced extraction. An efficient extraction system requires precision planning by a specialist qualified in this area and must comply with the positions, and distances indicated by the applicable standards.

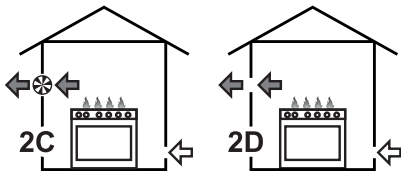
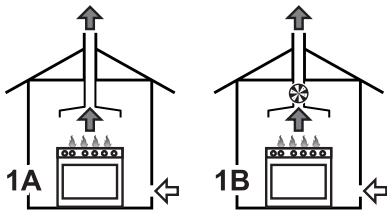

- 1 Extraction using a hood
- 2 Extraction without a hood
- A Single natural draught chimney
- B Single chimney with extractor fan
- C Directly outdoors with wall- or window-mounted extractor fan
- D Directly outdoors through wall

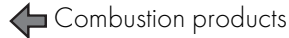

## 5.7 Adaptation to different types of gas

If other types of gas are to be used, the nozzles must be replaced and the primary air must be adjusted. In order to replace the nozzles and adjust the burners, the hob top must be removed.

### Removing the hob top

1. Remove the grids from the top; first the centre one than the lateral ones.

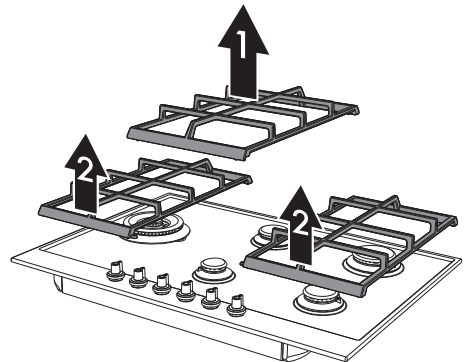

2. Remove the flame-spreader crowns and relative burner caps.

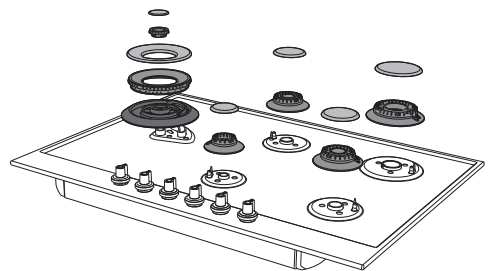



# Installation

3. Pull the knobs upwards to remove them.

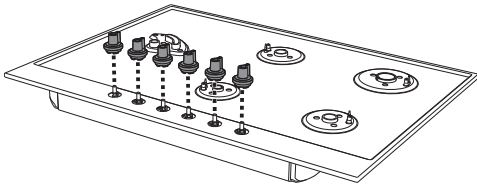

4. **Only for models with lateral UR:** lift the appliance from its housing and turn it upside down.

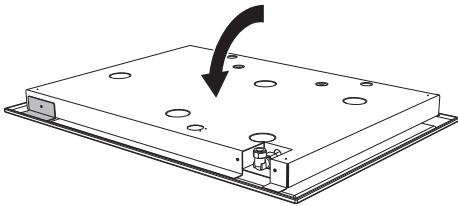

5. **Only for models with lateral UR:** remove the bracket fixing screw.

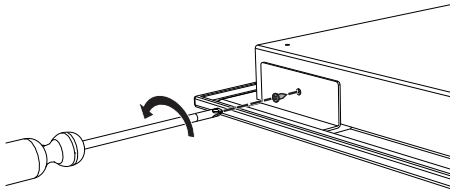

6. **Only for models with lateral UR:** pull out the bracket.

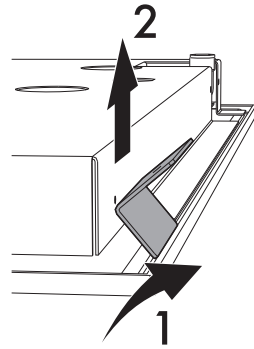

7. **Only for models with lateral UR:** put the appliance back in normal position.

8. For each burner, unscrew the three screws that fix the burner plates to the hob top.

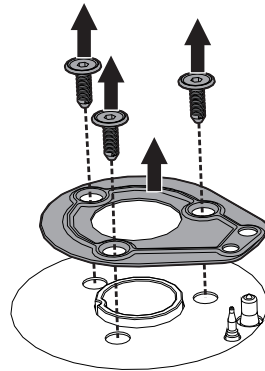





9. Remove the seals from the plugs and thermocouples of each burner.

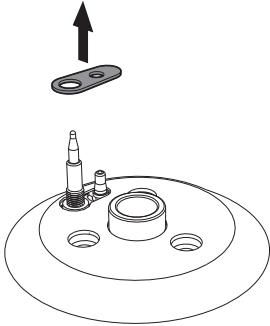

10. Lift the hob top and remove it.

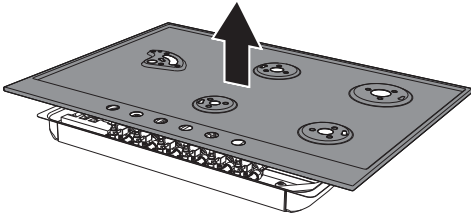

## Replacing nozzles

1. Undo the burner work surface fastening screw.

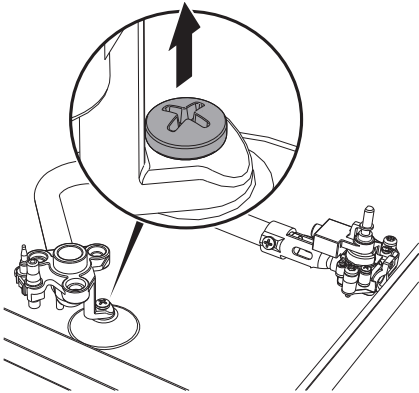

2. Remove the burner work surface and the corresponding gas supply hose.

3. Lift the trigger of the microswitch for the gas tap (1) then remove it (2).

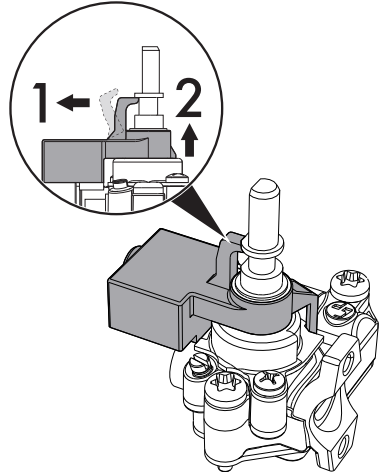

4. Use a 7-mm spanner to remove the nozzle and replace it with the new one for the required gas supply, following the indications given in the relevant tables (see Burner and nozzle specifications tables”).

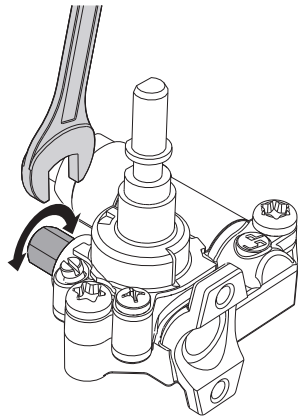

The nozzle tightening torque must be no more than 3 Nm.



# Installation

## Primary air adjustment

After removing the top, proceed as follows:

1. Loosen the screw **A**. Adjust the air flow by moving the air regulator **B** to obtain the distance **C** given in the relevant table (see "Burner and nozzle specifications tables").

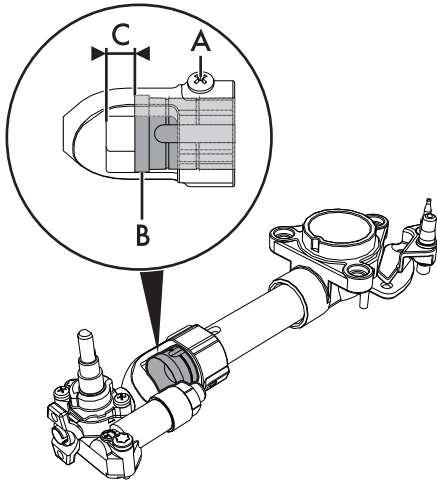

2. After adjusting each burner, reassemble the appliance correctly.

## Adjusting the minimum setting for natural gas

Light the burner and turn it to the minimum position. Extract the gas tap knob and turn the adjustment screw next to the tap rod (depending on the model) until the correct minimum flame is achieved.

Refit the knob and verify that the burner flame is stable. Turn the knob rapidly from the maximum to the minimum setting: the flame should not go out. Repeat the operation on all gas taps.

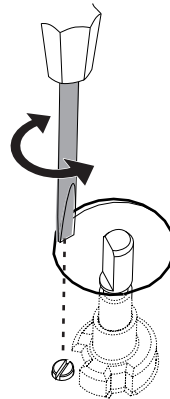



## Adjusting the minimum setting for LPG

- Tighten the screw located at the side of the tap rod clockwise all the way.



Following adjustment to a gas other than the one originally set in the factory, replace the gas setting label fixed to the appliance with the one corresponding to the new gas. The label is inserted inside the nozzle pack (where present)

## Lubricating the gas taps

Over time the gas taps may become difficult to turn and get blocked. Clean them internally and replace the lubrication grease.



Lubrication of the gas taps should be performed by a specialised technician.



# Installation

## Burner and nozzle specifications tables

NG 1.0 kPa	AUX	SR	RR	UR*	UR	UR2 (ext. +int.)
Nominal gas consumption (MJ/h)	5	6.5	10	13	15	11 + 4
Injector (1/100 mm)	0.98	1.10	1.40	1.60	1.70	1.50 + 0.85
Primary air (mm)	3	3	4	5	5	3 + 3
ULPG 2.75 kPa	AUX	SR	RR	UR*	UR	UR2 (ext. +int.)
Rated heating capacity (MJ/h)	4	6.5	10	12.6	15	11 + 4
Nozzle diameter (1/100 mm)	0.54	0.68	0.85	0.95	1.05	0.89 + 0.54
Primary air (mm)	2	2	3	3	4	4 + 2

The nozzles not provided are available at Authorised Service Centres.

## 5.8 Electrical connection



### Power voltage Danger of electrocution

- Have the electrical connection performed by authorised technical personnel.
- Use personal protective equipment.
- The appliance must be connected to earth in compliance with electrical system safety standards.
- Disconnect the main power supply.
- Do not pull the cable to remove the plug.
- Use cables withstanding a temperature of at least 90°C.
- The tightening torque of the screws of the terminal supply wires must be 1.5 - 2 Nm.

## General information

Check the grid characteristics against the data indicated on the plate.

The identification plate bearing the technical data, serial number and brand name is visibly positioned on the appliance.

Do not remove this plate for any reason.

Perform the ground connection using a wire that is 20 mm longer than the other wires.

The appliance can work in the following modes:

- **220-240 V 1N~**

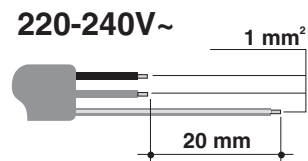

**3 x 1 mm<sup>2</sup> three-pole cable.**



The values indicated above refer to the cross-section of the internal lead.



## Fixed connection

Fit the power line with an omnipolar circuit breaker in compliance with installation regulations. The circuit breaker should be located near the appliance and in an easily reachable position.

For stationary appliances permanently connected to the fixed wiring, compliance with this requirement is considered to be met if the instruction concerning disconnection incorporated in the fixed wiring is in accordance with AS/NZS3000.

## Connection with plug and socket

Make sure that the plug and socket are of the same type.

Avoid using adapters and shunts as these could cause overheating and a risk of burns.

## Testing

At the end of installation, carry out a brief inspection test. If the cooktop fails to operate, after checking that you have carried out the instructions correctly, unplug the appliance and contact Technical Support.

## 5.9 Instructions for the installer

- The plug must be accessible after installation. Do not bend or trap the power cable.
- The appliance must be installed according to the installation diagrams.
- Do not try to unscrew or force the threaded elbow of the fitting. You may damage this part of the appliance, which may void the manufacturer's warranty.
- Use soap and water to check for gas leaks on all connections. **DO NOT** use naked flames to find leaks.
- Turn on all the burners separately and then all together to make sure that the gas valve, burner and ignition are working properly.
- Turn the burner knobs to the minimum position and check that the flame is stable for each individual burner and all the burners together.
- If the appliance does not work correctly after having carried out all the checks, contact your local Authorised Service Centre.
- Once the appliance has been installed, please explain to the user how to use it correctly.







914778177/D