

90cm 4 zone ceramic cooktop with Hob2Hood technology, flexible triple zone, and touch and slide controls

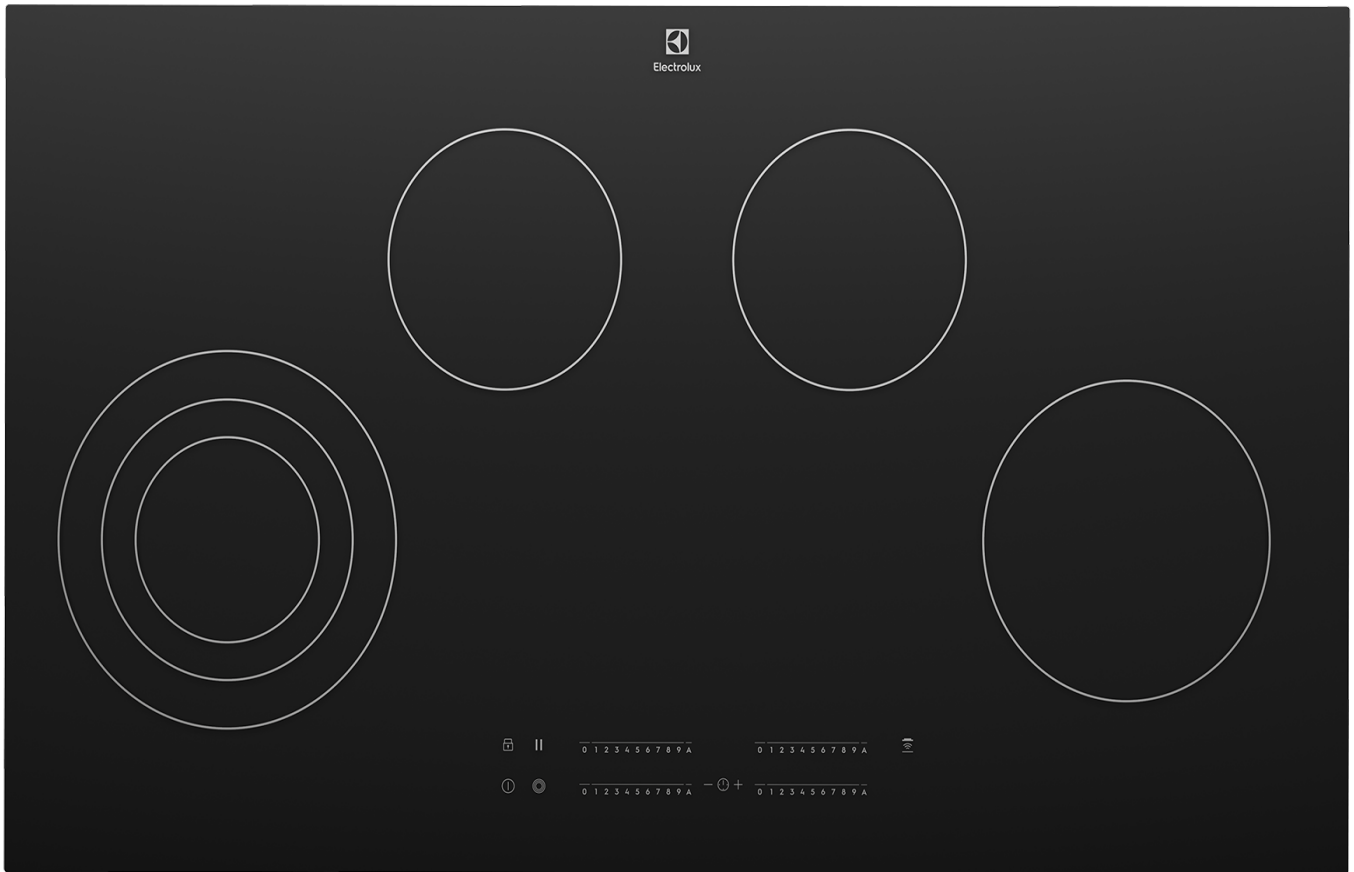

## Product Details

### FEATURES

---

Hob2Hood technology

Flexible triple zone

Touch and slide controls  
Touch the control bar at the  
necessary heat setting

STOP + GO function

---

Keep warm

Safety child lock

### BENEFITS

---

#### HANDS-FREE HOOD

Hob2Hood automatically switches on your extractor hood when you start cooking and adjusts the fan speed based on how you are using your hob. This means you can boil, sear or stir-fry without having to touch your hood with greasy fingers.

#### COOK. KEEP WARM. SERVE. ENJOY.

Getting your timings exactly right when cooking multiple dishes at the same is not easy. The keep warm function maintains a temperature of 80C so that you can keep dishes hot without continuing to cook them. This is perfect when youre multi-tasking to ensure that each dish arrives at the table hot, tasty, and ready to eat.

---

#### IT'S ALL ABOUT TIMING

Do you sometimes forget to turn off the hob after cooking? You don't have to worry if you set the timer. When the time is out and you're done cooking, your hob will automatically shut off for extra peace-of-mind.

#### KEEP YOUR LITTLE ONES SAFE

Activate the child lock function to prevent curious little helpers from turning on the hob when it's not in use. This feature gives you peace of mind when the family gathers in the kitchen.

---

#### EASY TO CLEAN SURFACE

Cleaning up after cooking can be a real pain, but the smooth glass surface makes it easy for you to wipe up spills.

#### INTUITIVE TOUCH CONTROLS

Sensitive touch controls take you from simmering to boiling and back again, almost instantly. This controllability allows you to apply precise changes that can take your dishes from tasty to truly delicious. Pan-sear steak with intense heat, and then instantly drop the temperature down to protect that beautifully juicy, medium-rare texture.

---

## Specifications

### PRODUCT PROFILE

---

Domestic warranty details (yrs)	2
Cooktop type	ceramic
Materials/Colour	black ceramic glass

---

### CONTROLS

---

Controls of Cooktops	Touch and Slide controls
Position of controls	front
Functions of Cooktops	stop and go,Keep warm function,auto heat up,cooking timer with acoustic signal,automatic switch off,Hob2Hood
Indicators/display	fault indicator,residual heat warning lamps

---

### DIMENSIONS

---

Total product height (mm)	55
Total product width (mm)	900
Total product depth (mm)	520
Cut out width (mm)	880
Cut out depth (mm)	490
Cut out height (mm)	51

---

### ELEMENTS/BURNERS

---

#### LEFT FRONT ZONE

---

Left front zone	ceramic triple
Left front Watts	2300
Left front diameter mm	210

---

## CONTROLS

---

Features of Cooktop	safety cut off,electronic timer,minute minder,safety child lock,hot surface indicator,sound off,Hob2Hood
---------------------	--

---

Timer of Cooktop	programmable 99min,countdown,Minute minder
------------------	---

---

## LEFT REAR ZONE

---

Left rear zone	ceramic
----------------	---------

---

Left rear watts	1200
-----------------	------

---

Left rear diameter mm	145
-----------------------	-----

---

## RIGHT REAR ZONE

---

Right rear zone	ceramic
-----------------	---------

---

Right rear watts	1200
------------------	------

---

Right rear diameter mm	145
------------------------	-----

---

## SHIPPING

---

Shipping Volume (m3)	0.065
----------------------	-------

---

## RIGHT FRONT ZONE

---

Right front zone	ceramic
------------------	---------

---

Right front Watts	1800
-------------------	------

---

Right front diameter mm	180
-------------------------	-----

---

## ELECTRICAL SPECIFICATIONS

---

Connected load KW	6.5
-------------------	-----

---

Type of connection	hardwired
--------------------	-----------

---

**SHIPPING**

---

Shipping Weight (Kg)	13
----------------------	----

---

Pack Dimensions Height (mm)	108
-----------------------------	-----

---

Pack Dimension Width (mm)	1000
---------------------------	------

---

Pack Dimension Depth (mm)	600
---------------------------	-----

---

## Dimensions

**Model:**  
EHC944BE

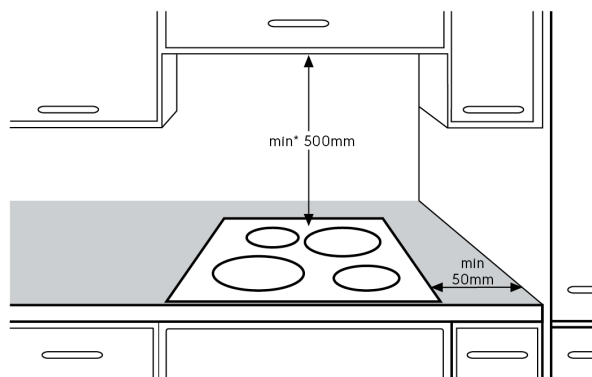
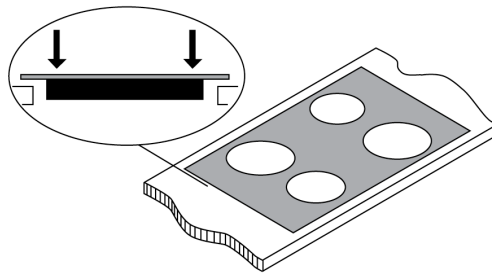
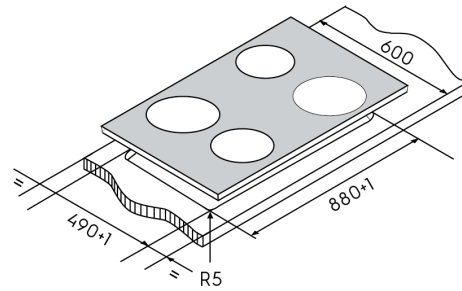

## Terms and Conditions

### IMPORTANT

This is a guide of product dimensions only. For complete installation instructions, refer to the manual provided with product.

### PRODUCT INFORMATION

The descriptors and illustrations in this publication apply to the specific products and models described as at the date of issue. Under our policy of continuous product development, product specifications may change without notice. Prospective purchasers should therefore check with their retailer to ensure this publication correctly describes the products that are being offered for sale. All information supplied is to be used for general reference purposes only and is on the understanding that Electrolux Home Products Pty Ltd (Australia) and Electrolux (NZ) Ltd (New Zealand) will not be liable for any loss, liability or damage of whatever kind arising as a result of reliance on such information. Colours of products illustrated are as close as printing limitations allow. Electrolux will at all times comply with its obligations pursuant to law including Trade Practices (Australian Consumer Law) Act and Regulations.

### WARRANTY

This warranty only applies to Appliances purchased and used in Australia or New Zealand and used in normal domestic applications and is in addition to (and does not exclude, restrict, or modify in any way) any non-excludable statutory warranties in Australia or New Zealand. All warranties are subject to the conditions set out in the warranty card accompanying the product when purchased.

#### ELECTROLUX HOME PRODUCTS AUSTRALIA

telephone: 1300 363 640

fax: 1800 350 067

email: [customercare@electrolux.com.au](mailto:customercare@electrolux.com.au)

web: [www.electrolux.com.au](http://www.electrolux.com.au)

#### ELECTROLUX HOME PRODUCTS NEW ZEALAND

telephone: 09 573 2230

fax: 09 573 2221

email: [customercare@electrolux.co.nz](mailto:customercare@electrolux.co.nz)

web: [www.electrolux.co.nz](http://www.electrolux.co.nz)