

# cooking collection

---

Instructions for use and warranty details

To register your warranty or make a warranty claim, scan this QR code:



Ceramic Cooktop  
Model No.:CCT9030

 **kLEENmaid**

Dear Customer,

Thank you and congratulations for choosing Kleenmaid.

Your new appliance has been designed and meticulously tested to ensure that it meets all your culinary requirements, and has been carefully manufactured using top quality materials to give you years of reliable performance.

For best results, carefully read the instructions on how your new appliance is to be installed. Correct installation will avoid delays and unnecessary service call costs.

Once installation is complete, please read this instruction manual carefully and get to know the controls and the features of your new Kleenmaid appliance. These simple instructions will enable you to achieve excellent results from the very first time you use it.

Again, congratulations and thank you for choosing The Best You Can Own.

KLEENMAID

# Content

<b>Safety Warnings</b> .....	<b>4</b>
Installation.....	4
Electrical Shock Hazard.....	4
Cut Hazard.....	4
Important safety instructions.....	4
Operation and maintenance.....	4
Electrical Shock Hazard.....	4
Health Hazard.....	4
Hot Surface Hazard .....	4
Cut Hazard.....	5
Important safety instructions.....	5
<b>Product Overview</b> .....	<b>6</b>
Top View.....	6
Control Panel.....	6
Before using your New Ceramic Cooktop.....	7
Choosing the right Cookware.....	7
<b>Using your Ceramic Cooktop</b> .....	<b>8</b>
Start and Finish cooking.....	8
Safety Features.....	9
Using the Timer.....	10
Using the Recall Function.....	13
Using the Pause/Resume Function.....	13
Using the Keep Warm Function.....	13
Using the Automatic Cooking Function.....	13
<b>Cooking Guidelines</b> .....	<b>14</b>
Cooking Tips.....	14
Simmering, cooking rice.....	14
Searing steak.....	14
For stir-frying.....	15
<b>Heat Settings</b> .....	<b>15</b>
<b>Care and Cleaning</b> .....	<b>16</b>
<b>Trouble Shooting</b> .....	<b>17</b>
Technical Specification.....	17
<b>Installation</b> .....	<b>18</b>
Selection of installation equipment.....	18
Before locating the fixing brackets.....	19
Cautions.....	19
Connecting the cooktop to the mains power supply.....	20

## Safety Warnings

Your safety is important to us. Please read this information before using or installing your cooktop. The latest version of this manual is available on our website. (See back cover for details.)

### Installation

#### Electrical Shock Hazard

- Disconnect the appliance from the mains electricity supply before carrying out any work or maintenance on it.
- Connection to a good earth wiring system is essential and mandatory.
- Alterations to the domestic wiring system must be only made by a qualified electrician.
- Failure to follow this advice may result in electrical shock or death.

#### Cut Hazard

- Take care - panel edges are sharp.
- Failure to use caution could result in cuts or other injury.

#### Important safety instructions

- Read these instructions carefully before installing or using this appliance.
- No combustible material or products should be placed on this appliance at any time.
- Please make this information available to the person responsible for installing the appliance as it could reduce your installation costs.
- In order to avoid a hazard, this appliance must be installed according to these instructions for installation.
- Before making preparations for or commencing installation, the installer should refer to the current online version of the User Manual, which is available on the Kleenmaid website (see back cover for details).
- This appliance is to be properly installed and earthed only by a suitably qualified person.
- This appliance should be connected to a circuit which incorporates an isolating switch providing full disconnection from the power supply in accordance with the wiring rules.
- Failure to install the appliance correctly could invalidate any warranty or liability claims.

### Operation and Maintenance

#### Electrical Shock Hazard

- Do not cook on a broken or cracked cooktop. If the cooktop surface should break or crack, switch the appliance off immediately at the mains power supply and contact a qualified technician.
- Switch the cooktop off at the wall before cleaning or maintenance.
- Failure to follow this advice may result in electrical shock or death.

#### Health Hazard

- This appliance complies with electromagnetic safety standards.

#### Hot Surface Hazard

- During use, accessible parts of this appliance will become hot and may cause burns.
- Do not let your body, clothing or any item other than suitable cookware contact the glass until the surface is cool.

- Metallic objects such as knives, forks, spoons and lids should not be placed on the cooktop surface since they can get hot.
- Keep children away from the cooktop when in use.
- Handles of saucepans may be hot to touch. Check that saucepan handles do not overhang other active cooking zones. Keep handles out of reach of children.
- Failure to follow this advice could result in burns and scalds.

### **Cut Hazard**

- The razor-sharp blade of a cooktop scraper is exposed when the safety cover is retracted. Use with extreme care and always store safely and out of the reach of children.

Failure to use caution could result in cuts or other injury.

### **Important safety instructions**

- Never leave the appliance unattended when in use. A boilover causes smoking and greasy spills that may ignite.
- Never use your appliance as a work or storage surface.
- Never leave any objects or utensils on the appliance.
- Never use your appliance for warming or heating the room.
- After use, always turn off the cooking zones and the cooktop as described in this manual (i.e. by using the touch controls).
- Do not allow children to play with the appliance or sit, stand, or climb on it.
- Do not store items of interest to children in cabinets above the appliance. Children climbing on the cooktop could be seriously injured.
- Do not leave children alone or unattended in the area where the appliance is in use.
- Do not repair or replace any part of the appliance unless specifically recommended in the manual. All other servicing should be done by a qualified technician.
- Do not use a steam cleaner to clean your cooktop.
- Do not place or drop heavy objects on your cooktop.
- Do not stand on your cooktop.
- Do not use pans with jagged edges or drag pans across the glass surface as this can scratch the glass.
- Do not use scourers or any other harsh abrasive cleaning agents to clean your cooktop, as these can scratch the glass.
- If the supply cord is damaged, it must be replaced by the manufacturer, its service agent or similarly qualified persons in order to avoid a hazard.
- This appliance is intended to be used in household and similar applications such as:
  - staff kitchen areas in shops, offices and other working environments
  - farm houses
  - by clients in hotels, motels and other residential type environments
  - bed and breakfast type environments.
- **WARNING:** The appliance and its accessible parts become hot during use. Care should be taken to avoid touching heating elements. Children shall be kept away unless continuously supervised.
- This appliance is not intended for use by persons (including children) with reduced physical, sensory or mental capabilities, or lack of experience and knowledge unless they have been given supervision or instruction concerning use of the appliance by a person responsible for their safety.
- Children should be supervised to ensure that they do not play with the appliance.
- Cleaning and user maintenance shall not be made by children without supervision.
- **WARNING:** Unattended cooking on a hob with fat or oil can be dangerous and may result in fire. NEVER try to extinguish a fire with water, but switch off the appliance and then cover flame e.g. with a lid or a fire blanket.

- WARNING: Danger of fire: do not store items on the cooking surfaces.
  - WARNING: For cooktop surfaces of glass-ceramic or similar material which protects live parts, if the surface is cracked, switch off the appliance to avoid the possibility of electric shock.
  - A steam cleaner is not to be used.
  - The appliance is not intended to be operated by means of an external timer or separate remote-control system.
- CAUTION: The cooking process has to be supervised. A short term cooking process has to be supervised continuously.
- WARNING: Do not use cooktop guards of any type. The use of inappropriate guards can cause accidents.
- NOTE: This appliance incorporates an earth connection for functional purposes only.

Please read all the safety instructions carefully before use and keep this User Manual for future reference.

## Product Overview

### Top View

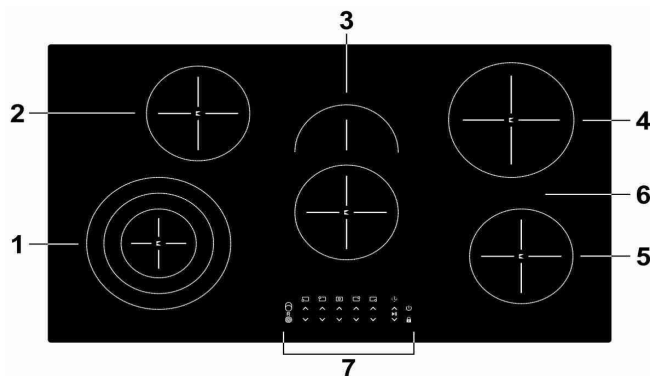

1. 800/1600/2300 W Extendable Triple Zone
2. 1200 W Zone
3. 1100/2000 W Extendable Oval Zone
4. 1800 W Zone
5. 1200 W Zone
6. Glass Plate
7. Control Panel

### Control Panel

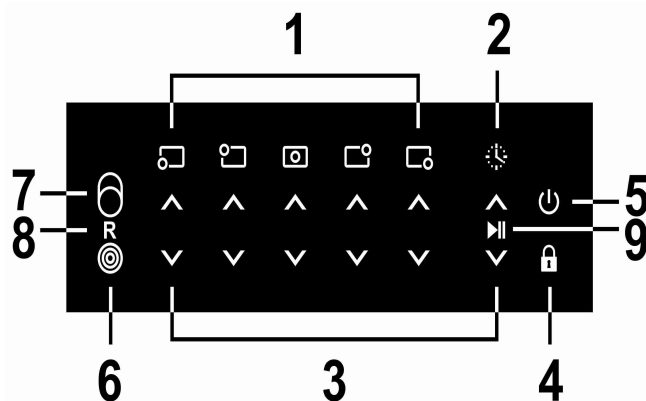

1. Cooking Zone Position Icons
2. Timer Function Icon
3. Power/ Timer Regulating Keys
4. Child Lock Key
5. ON/OFF Keys
6. Triple Zone Key
7. Oval Zone Key
8. "R" Recall Function (Ⓞ + Ⓞ)
9. ⏸ Pause Function (⬆ + ⬇)

## Before using your New Ceramic Cooktop

- When unpacking the cooktop please ensure that all contents of the carton are removed prior to disposing of the packaging. These articles should be retained for the installer.  
Contents include:
  - 1 x Ceramic Cooktop
  - 1 x User Manual
  - 4 x Brackets
  - 4 x Screws
  - 1 x Foam seal
- Read this guide, taking special note of the 'Safety Warnings' section.
- Remove any protective film that may still be on your ceramic cooktop.

## Using the Control Keys

- The controls respond to touch, so you don't need to apply any pressure.
- Use the ball of your finger, not its tip.
- You will hear a beep each time a touch is registered.
- Make sure the controls are always clean, dry, and that there is no object (e.g. a utensil or a cloth) covering them. Even a thin film of water may make the controls difficult to operate.
- To select a Cooking Zone, touch the "▲" key in front of the relevant Zone Position Key.

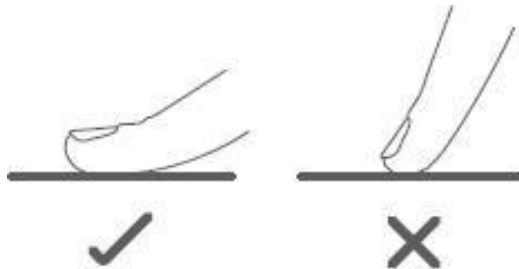

## Choosing the right Cookware

Do not use cookware with jagged edges or a curved base.

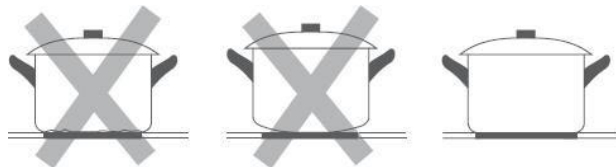

Make sure that the base of your pan is smooth, sits flat against the glass, and is the same size as the cooking zone. Always centre your pan on the cooking zone.

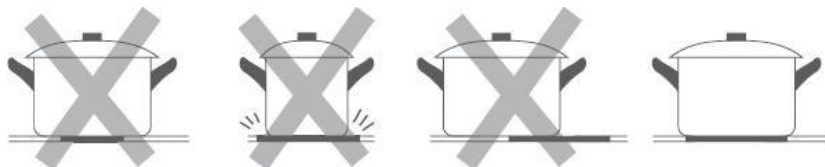

Always lift pans off the ceramic cooktop – do not slide, or they may scratch the glass.

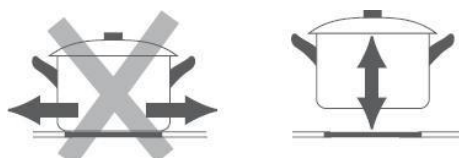



## Using your Ceramic Cooktop

### To start cooking

- After the power is switched on, the audible alert chimes once, all the indicators light up for 1 second then go out, indicating that the cooktop has entered the state of standby mode.
1. Touch the ON/OFF key. All the indicators show "-"
  2. Place a suitable pan on the selected cooking zone. Make sure the bottom of the pan and the surface of the cooking zone are clean and dry.
  3. Touch the Power Regulation Key immediately in front of the Cooking Zone Position Icon for the selected cooking zone.
  4. Select a heat setting by pressing repeatedly on the "V" or "Λ" Power Regulating Keys. Do not press and hold.
    - If you don't choose a heat setting within 1 minute, the cooktop will automatically switch off. You will need to start again at Step 1.
    - You can modify the heat setting at any time during cooking.



### To activate triple or oval extendable cooking zones

1. Follow Steps 1- 4 above. At Step 3 choose the Power Regulation Key immediately in front of Cooking Zone Position Icon **1** if planning to use the triple extendable zone, or in front of Cooking Zone Position Icon **3** if using the oval extendable zone. (See Product Overview page 6.)
2. After choosing the heat setting at Step 4 touch the triple zone  or oval zone  key and the cooktop will start working from the inner area of the zone. Touch the triple zone key one or two more times, while the zone display is still flashing, to enlarge the zone to suit your pan size.

If the zone display has stopped flashing prior to the completion of your selection, start again at Step 1.

Note: Follow the instructions below to turn off the cooking zone or cooktop.

### When you have finished cooking

1. Touch the Power Regulation Key immediately in front of the Cooking Zone Position Icon for the zone you wish to switch off.
2. Turn the cooking zone off by touching the "V" power regulating key repeatedly until it reaches 0. The related zone power level display will then show "H".
3. Turn the whole cooktop off by touching the "ON/OFF" key.
4. Beware of hot surfaces. "H" will show which cooking zone is hot to touch. It will disappear when the surface has cooled down to a safe temperature. It can also be used as an energy saving function. If you want to heat further pans, use a hotplate that is still hot.

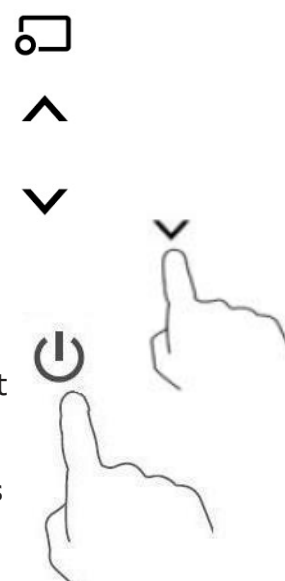



# Safety Features

## Locking the Controls

- You can lock the controls to prevent unintended use, for example children accidentally turning on the cooking zones.
- When the controls are locked all the keys except the ON/OFF key are disabled.

### To lock the controls

Touch the child lock  key. The timer indicator will show " Lo "

### To unlock the controls

1. Make sure the cooktop is turned on.
2. Touch and hold the child lock  key for 3 seconds.
3. You can now start using your cooktop.



When the cooktop is in lock mode, all the keys are disabled except the ON/OFF key. You can always turn the cooktop off with the ON/OFF key in an emergency, but you should unlock the cooktop first before the next use.

## Over-Temperature Protection

An inbuilt temperature sensor monitors the temperature inside the cooktop. When an excessive temperature is detected, the cooktop will stop operation automatically.

## Spill Protection

The cooktop will beep and shut down after a certain quantity of liquid overflows onto the controls. Should this occur, turn off the power, follow the usual precautions for cleaning up hot liquids and ensure the cooktop is dry before recommencing cooking. (See Care and Cleaning page 16.)

## Residual Heat Warning

When the cooktop has been operating for some time, there will be residual heat. The letter " H " appears as a warning against possible injury from hot surfaces.

## Auto Shutdown

Another safety feature of the cooktop is auto shut down. This occurs whenever you forget to switch off a cooking zone. The maximum shutdown times (in hours) are shown in the table below:

<b>Power level</b>	1	2	3	4	5	6	7	8	9
<b>Maximum operating time (hrs)</b>	8	8	8	4	4	4	2	2	2

## Using the Timer

You can use the timer in two different ways:

- You can use it as a minute minder. In this case, the timer will not turn any cooking zone off when the set time expires.
- You can set it to turn one or more cooking zones off after the set time expires. The timer can be set for up to 99 minutes.

### Using the Timer as a Minute Minder

#### If you are not selecting any cooking zone

1. Make sure the cooktop is turned on.

Note: You can use the minute minder even if you're not selecting any cooking zones.

2. Touch the Timer Regulation Key "▲" in front of the Timer Function Icon then the timer display shows "--".



3. Adjust the timer setting by touching the timer regulating keys "▼" or "▲". The timer display will start flashing and the remaining time will show on the display.

Hint: Touch the "▼" or "▲" timer regulating key once to decrease or increase the time by 1 minute.

Touch and hold the "▼" or "▲" timer regulating key to decrease or increase the time by 10 minutes.

If the setting time exceeds 99 minutes, the timer will automatically return to 0.

4. To cancel the timer, touch the "▲" or "▼" controls of the timer, and scroll down to "0". The timer is cancelled, "00" will show in the minute display and then "--".



5. When the timer is set, it will begin to count down immediately. The display will show the remaining time and will flash for 5 seconds.

6. When the set time expires the audible alert will chime for 30 seconds and the timer display will show "- -".

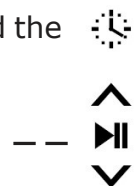

## Setting the timer to turn off one cooking zone

1. Touch the Timer Regulation Key "▲" immediately in front of the associated Cooking Zone Position Icon to choose the zone to be timed.
2. Touch the Timer Regulation Key "▲" immediately in front of the Timer Function Icon, then the timer display will show "30".
3. Set the time by touching the "▼" or "▲" timer regulating keys related to the timer function.  
Hint: Touching the "▼" or "▲" timer regulating key once will decrease or increase the time by 1 minute.  
Touching and holding the "▼" or "▲" timer regulating key will decrease or increase the time by 10 minutes.  
If the setting time exceeds 99 minutes, the timer will automatically return to 0 minute.
4. To cancel, touch the Timer Regulation Key "▼" or "▲" immediately in front of the associated Cooking Zone Position Icon, and then touch the Timer Regulation Key "▼" or "▲" immediately in front of the Timer Function Icon and scroll down to "0". The timer is cancelled, and "00" will show in the timer display then "--".
5. When the timer is set, it will begin to count down immediately. The display will show the remaining time and will flash for 5 seconds.  
NOTE: The red dot next to the power level display will illuminate indicating that zone is selected.
6. When the cooking timer expires, the corresponding cooking zone will automatically switch off and show "H" in the display.  
NOTE: If you want to change the time after the timer is set, start again from step 1.



## The timer may be set to turn off more than one cooking zone

1. If the function is used for more than one cooking zone, the timer will show the shortest time that has been set.  
(e.g. If zone 2 has a set time of 3 minutes, and zone 3 has a set time of 6 minutes, the timer indicator will show "3".)

NOTE: A flashing red dot next to a power level display means the timer display is showing the remaining set time for that cooking zone. If you want to check the remaining set time of the other cooking zone, touch the Power Regulation Key immediately in front of the Cooking Zone Position Icon for the zone you wish to check. The timer display will indicate its set time.

(set to 6 minutes)



(set to 3 minutes)

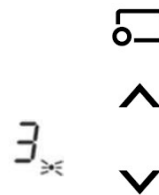

2. When a set cooking time is reached, the corresponding cooking zone will switch off automatically.

## Using the Recall Function

The Recall Function is a feature which enables the recovery of power levels and timer settings after the cooktop has been switched OFF unintentionally. In standby mode after turning on the cooktop (but not touching any other key), touch and hold the triple zone and oval zone keys on the left simultaneously for 3 seconds. (See "R" on Control Panel page 6.) The Recall Function is activated, and the cooking functions used last before the cooktop was turned off will be recovered.

## Using the Pause/Resume Function

Touching the "V" and "A" keys related to the timer function key simultaneously for 3 seconds will pause all the cooking functions and the LED display will show "II". (See  on Control Panel page 6.) To resume, touch the "V" and "A" keys related to the timer function key together for 3 seconds again. During the pause status, if there is no operation on the controls for 2 hours, the cooktop will switch off automatically.



## Using the Keep Warm Function

The Keep Warm function is intended to keep cooked food warm. Choose the cooking zone you want to use for this function, and touch and hold the related "V" power regulating key for 3 seconds. The Keep Warm function is activated and the LED display shows "U". To quit this function, touch and hold the "V" power regulating key for 3 seconds again. The Keep Warm function will last for 2 hours, and after that time the cooking zone will return to standby mode.

## Using the Automatic Cooking Function

Automatic Cooking is a feature which enables heating up a cold pot at full heating power then returning automatically to a desired pre-set cooking level. This function takes the cooking zone to maximum power in a very short time.

To activate Automatic cooking:

1. Touch the Power Regulation Key immediately in front of the Cooking Zone Position Icon for the selected cooking zone. 
2. Set the desired cooking level by pressing the "A" power regulation key repeatedly until the desired power setting is reached. 
3. Immediately press and hold the "A" power regulating key until the LED display shows "A" (approx 3 seconds). The Automatic Cooking Function is activated. After five minutes heating at the highest power level, the pre-set cooking level is displayed and the selected zone will continue heating at this cooking level set before the function was activated. 

To quit the Automatic Cooking function, touch and hold the "A" power regulating key again for 3 seconds.

# Cooking Guidelines

## Cooking Tips

- When food comes to the boil, reduce the power setting.
- Using a lid will reduce cooking times and save energy by retaining the heat.
- Minimise the amount of liquid or fat to reduce cooking times.
- Start cooking on a high setting and reduce the setting when the food has heated through.

## Simmering, cooking rice

- Simmering occurs below boiling point, at around 85°C, when bubbles are just rising occasionally to the surface of the cooking liquid. It is the key to delicious soups and tender stews because the flavours develop without overcooking the food. You should also cook egg-based and flour-thickened sauces below boiling point.
- Some tasks, including cooking rice by the absorption method, may require a setting higher than the lowest setting to ensure the food is cooked properly in the time recommended.

## Searing steak

To cook juicy flavoursome steaks:

1. Stand the meat at room temperature for about 20 minutes before cooking.
2. Heat up a heavy-based frying pan.
3. Brush both sides of the steak with oil. Drizzle a small amount of oil into the hot pan and then lower the meat onto the hot pan.
4. Turn the steak only once during cooking. The exact cooking time will depend on the thickness of the steak and the doneness you prefer. Times may vary from about 2 – 8 minutes per side. Press the steak to gauge how cooked it is - the firmer it feels the more 'well done' it will be.
5. Leave the steak to rest on a warm plate for a few minutes to allow it to relax and become tender before serving.

### For stir-frying

1. Choose a ceramic compatible flat-based wok or a large frying pan.
2. Have all the ingredients and equipment ready. Stir-frying should be quick. If cooking large quantities, cook the food in several smaller batches.
3. Preheat the pan briefly and add two tablespoons of oil.
4. Cook any meat first, put it aside and keep warm.
5. Stir-fry the vegetables. When they are hot but still crisp, turn the cooking zone to a lower setting, return the meat to the pan and add your sauce.
6. Stir the ingredients gently to make sure they are heated through.
7. Serve immediately.

## Heat Settings

Heat setting	Suitability
1 - 2	<ul style="list-style-type: none"><li>• delicate warming for small amounts of food</li><li>• melting chocolate, butter, and foods that burn quickly</li><li>• gentle simmering</li><li>• slow warming</li></ul>
3 - 4	<ul style="list-style-type: none"><li>• reheating</li><li>• rapid simmering</li><li>• cooking rice</li></ul>
5 - 6	<ul style="list-style-type: none"><li>• pancakes</li></ul>
7 - 8	<ul style="list-style-type: none"><li>• sauteing</li><li>• cooking pasta</li></ul>
9	<ul style="list-style-type: none"><li>• stir-frying</li><li>• searing</li><li>• bringing soup to the boil</li><li>• boiling water</li></ul>

## Care and Cleaning

What?	How?	Important!
<p>Everyday soiling on glass (fingerprints, marks, stains left by food or non-sugary spillovers on the glass)</p>	<ol style="list-style-type: none"> <li>1. Switch the power to the cooktop off.</li> <li>2. Apply a cooktop cleaner while the glass is still warm (but not hot!)</li> <li>3. Rinse and wipe dry with a clean cloth or paper towel.</li> <li>4. Switch the power to the cooktop back on.</li> </ol>	<ul style="list-style-type: none"> <li>• When the power to the cooktop is switched off, there will be no 'hot surface' indication but the cooking zone may still be hot! Take extreme care.</li> <li>• Heavy-duty scourers, some nylon scourers and harsh/abrasive cleaning agents may scratch the glass. Always read the label to check if your cleaner or scourer is suitable.</li> <li>• Never leave cleaning residue on the cooktop: the glass may become stained.</li> </ul>
<p>Boilovers, melts, and hot sugary spills on the glass</p>	<p>Remove these immediately with a fish slice, palette knife or razor blade scraper suitable for ceramic glass cooktops, but beware of hot cooking zone surfaces:</p> <ol style="list-style-type: none"> <li>1. Switch the power to the cooktop off at the wall.</li> <li>2. Hold the blade or utensil at a 30° angle and scrape the soiling or spill to a cool area of the cooktop.</li> <li>3. Clean the soiling or spill up with a dish cloth or paper towel.</li> <li>4. Follow steps 2 to 4 for 'Everyday soiling on glass' above.</li> </ol>	<ul style="list-style-type: none"> <li>• Remove stains left by melts and sugary food or spillovers as soon as possible. If left to cool on the glass, they may be difficult to remove or even permanently damage the glass surface.</li> <li>• Cut hazard: when the safety cover is retracted, the blade in a scraper is razor-sharp. Use with extreme care and always store safely and out of reach of children.</li> </ul>
<p>Spillovers on the touch controls</p>	<ol style="list-style-type: none"> <li>1. Switch the power to the cooktop off.</li> <li>2. Soak up the spill</li> <li>3. Wipe the touch control area with a clean damp sponge or cloth.</li> <li>4. Wipe the area completely dry with a paper towel.</li> <li>5. Switch the power to the cooktop back on.</li> </ol>	<ul style="list-style-type: none"> <li>• The cooktop may beep and turn itself off, and the touch controls may not function while there is liquid on them. Make sure you wipe the touch control area dry before turning the cooktop back on.</li> </ul>



## Trouble Shooting

Problem	Possible causes	What to do
The cooktop cannot be turned on.	No power.	Make sure the cooktop is connected to the power supply and that it is switched on. Check whether there is a power outage in your home or area. If you've checked everything and the problem persists, call a qualified technician.
The touch controls are unresponsive.	The controls are locked.	Unlock the controls. See section 'Using your ceramic cooktop' on page 9 for instructions.
The touch controls are difficult to operate.	There may be a slight film of water over the controls or you may be using the tip of your finger when touching the controls.	Make sure the touch control area is dry and use the ball of your finger when touching the controls.
The glass is being scratched.	Rough-edged cookware.  Unsuitable, abrasive scourer or cleaning products being used.	Use cookware with flat and smooth bases. See 'Choosing the right cookware' on page 7.  See 'Care and cleaning' on page 16.
Some pans make crackling or clicking noises.	This may be caused by the construction of your cookware (layers of different metals vibrating differently).	This is normal for cookware and does not indicate a fault.

If the appliance fails to operate correctly during the warranty period please visit our website to request a warranty service (see back cover of this manual for details). When booking a service please provide your Model No: CCT9030 and the individual Serial Number of your appliance. This is found on the rating label on the underside of the cooktop or on your appliance paperwork.

## Technical Specification

Cooktop model	CCT9030
Cooking Zones	5 Zones
Supply Voltage	220-240V~,50~60Hz
Absorbed Electric Power	7777-9255W
Product Size                   WxD×H(mm)	900*520*52
Cutout Dimensions       A×B (mm)	870*490
Current Rating (1P/2P)	40A/24A

Weight and Dimensions are approximate. Because we continually strive to improve our products we may change specifications and designs without prior notice.

# Installation

Before making preparations for or commencing installation, the installer should refer to the current online version of the User Manual, which is available on the Kleenmaid website (see back cover for details).

## Selection of installation equipment

Cut out the work surface according to the sizes shown in the drawing. For the purpose of installation and use, a minimum of 50mm space shall be preserved around the hole.

Be sure the thickness of the work surface is at least 30mm. Please select heat-resistant work surface material to avoid deformation caused by the heat radiation from the hotplate. See diagram and table below:

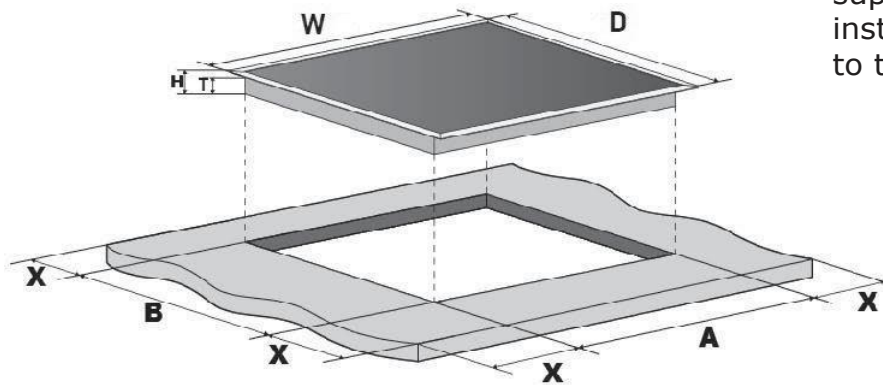

Note: The seal is a factory supplied foam strip. See instructions to attach this to the cooktop on page 19.

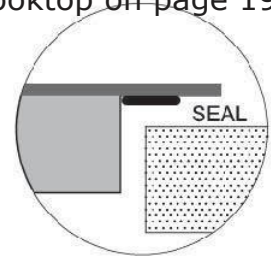

W(mm)	D(mm)	H(mm)	T(mm)	A(mm)	B(mm)	X(mm)
900	520	52	48	870	490	50 min.

Under all circumstances, make sure the ceramic cooktop is well ventilated and the air inlet and outlet are not blocked. Ensure the ceramic cooktop is positioned correctly as shown below.

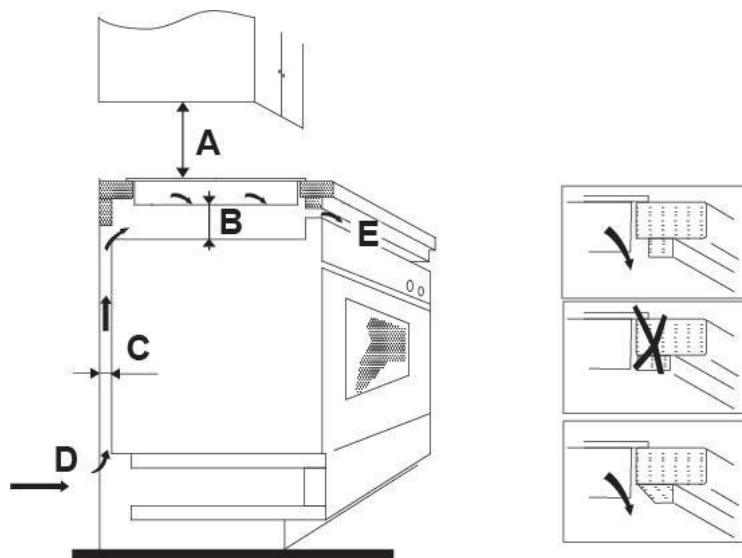

A(mm)	B(mm)	C(mm)	D	E
600	50 min	30 min	Air intake	Air exit 10 mm



NOTE: The safety distance between the hotplate and the cupboard above the hotplate should be at least 760mm.



NOTE: The safety gap between the cooktop and the rangehood placed above must comply with the recommendations of the rangehood manufacturer. In case of no instructions, a minimum distance of 650mm (or other minimum distance as may be specified by AS/NZS 5601 and interpreted by a certified installer) should apply.

## Attaching the seal to the cooktop

The seal should be attached to the cooktop by following the instructions below before the cooktop is installed into the benchtop cut out.

- The unit should be placed on a stable, smooth surface (eg. use the packaging as padding).
- Clean the cooktop in the area of the cut out section.
- Carefully remove the backing tape from the seal before applying to the cooktop.
- Attach the seal along the outer edge of the glass plate. Do not stretch or extend it. The 2 ends should meet in the centre of one side.
- Cut off any excess foam strip ensuring the 2 ends push together without any gap.

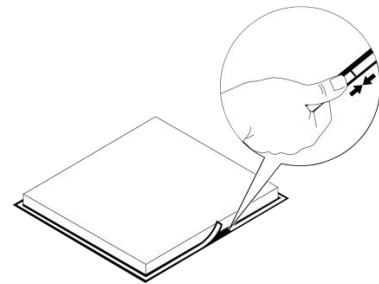

## Locating the fixing brackets

The unit should be placed on a stable, smooth surface (use the packaging as padding). Do not apply force.

Fix the cooktop to the work surface by attaching the four brackets to the bottom of the cooktop after checking placement within the cut out (see picture).

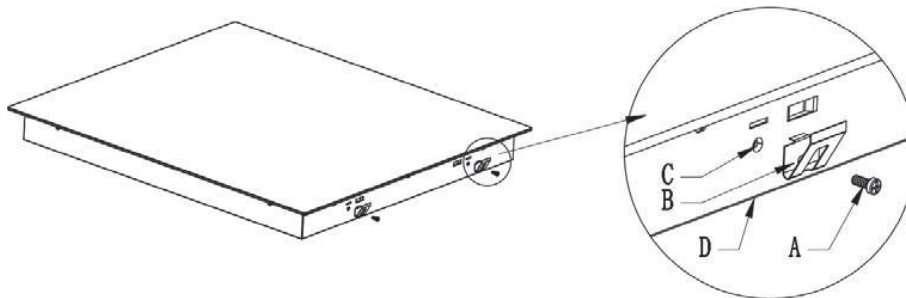

A	B	C	D
Screw	Bracket	Screw hole	Base

Adjust the bracket position to suit the thickness of the work surface.

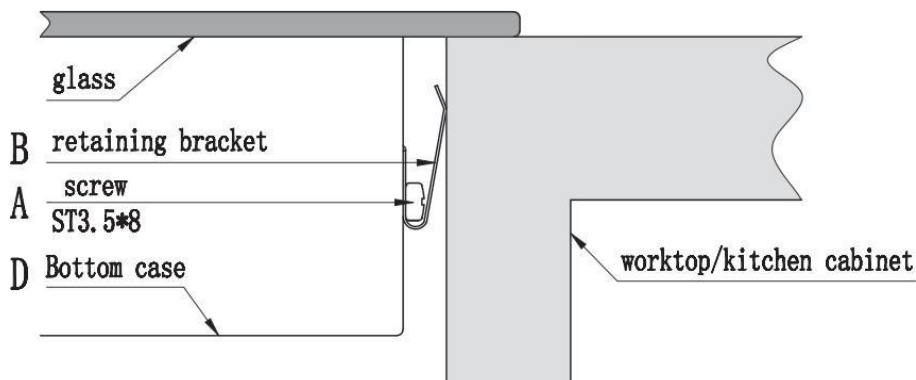

## Cautions



1. The cooktop must be installed by qualified personnel or technicians. If necessary, see the "Support" section on our website for suitably qualified installers. Unqualified persons should not attempt to install this appliance.
2. The ceramic cooktop should not be mounted to cooling equipment, dishwashers or rotary dryers.
3. The ceramic cooktop shall be installed such that sufficient heat radiation can be ensured to enhance its reliability.
4. The wall and induced heating zone above the work surface should be heat resistant.
5. To avoid any damage, the sandwich layer and adhesive must be resistant to heat.
6. A steam cleaner is not to be used.
7. This cooktop can be connected only to a supply with system impedance no more than 0.427 ohm. If necessary, please consult your supply authority for system impedance information.

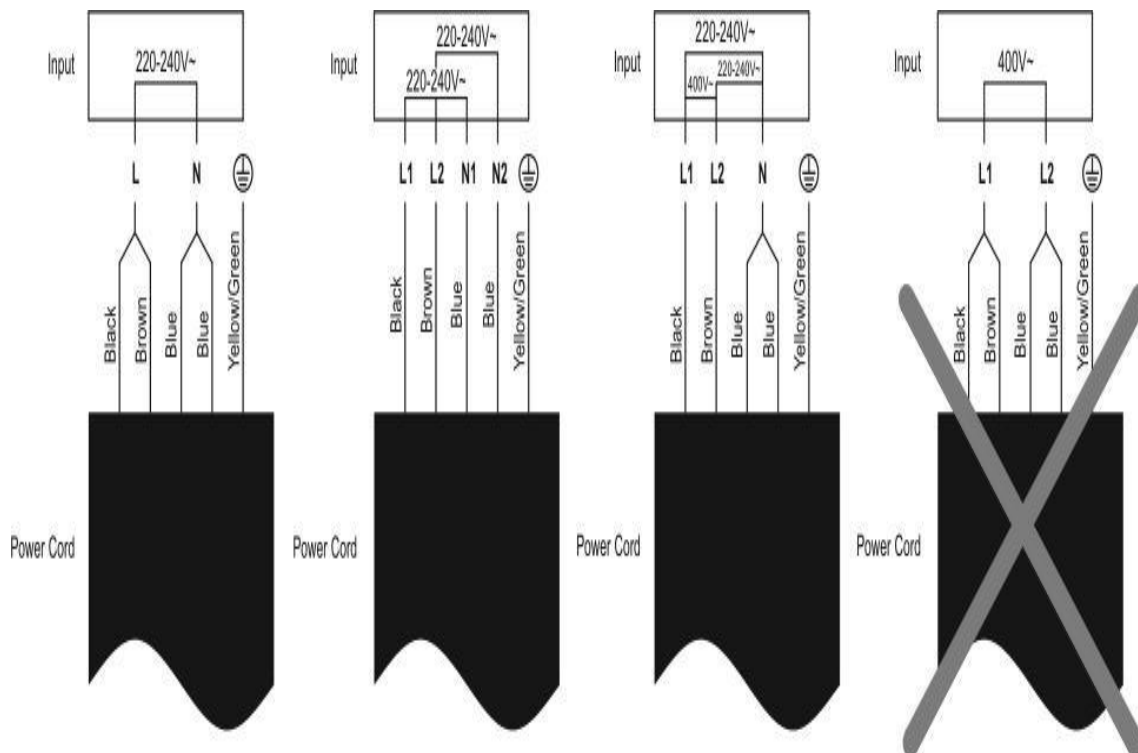

## Connecting the cooktop to the mains power supply

The power supply should be connected in compliance with the relevant standard, or a multiple-pole circuit breaker. The method of connection is shown below.



1. If the supply cord is damaged, it must be replaced by the manufacturer, its service agent or similarly qualified persons in order to avoid a hazard.
2. If the appliance is being connected directly to the mains supply, an omnipolar circuit breaker must be installed with a minimum gap of 3mm between the contacts.
3. The installer must ensure that the correct electrical connection has been made and that it complies with safety regulations.
4. The cable must not be bent or compressed.
5. The cable must be checked regularly and only replaced by a properly qualified person.

	<p><b>WARNING: IT MUST BE ENSURED THAT THIS APPLIANCE IS CONNECTED ONLY TO A 230VAC +10%/-6% 50Hz MAINS POWER SUPPLY WHICH CONTINUOUSLY COMPLIES WITH THE RELEVANT AUSTRALIAN STANDARD. FAILURE TO DO SO MAY SERIOUSLY DAMAGE THE APPLIANCE AND ANY SUCH DAMAGE IS NOT COVERED BY THE MANUFACTURER'S WARRANTY.</b></p>	
---	--	---

 	<p>This appliance is labeled in compliance with European directive 2012/19/EU for Waste Electrical and Electronic Equipment (WEEE). By ensuring that this appliance is disposed of correctly, you will help prevent any possible damage to the environment and to human health, which might otherwise be caused if it were disposed of in the wrong way.</p> <p>The symbol on the product indicates that it may not be treated as normal household waste. It should be taken to a collection point for the recycling of electrical and electronic goods.</p> <p>This appliance requires specialist waste disposal. For further information regarding the treatment, recover and recycling of this product please contact your local council, your household waste disposal service, or the shop where you purchased it.</p>
<p><b>DISPOSAL: Do not dispose of this product as unsorted municipal waste. Collection of such waste separately for special treatment is necessary.</b></p>	

# KLEENMAID WARRANTY

## TERMS AND CONDITIONS

1. Compass Capital Services Pty Ltd ABN 96 138 214 525 trading as Kleenmaid will provide parts and labour to you the customer as set out herein.
2. Kleenmaid may engage a Service Agent to provide service under this warranty.
3. Kleenmaid's Products come with guarantees that cannot be excluded under the Australian Consumer Law. You are entitled to a replacement or refund for a major failure and for compensation for any other reasonably foreseeable loss or damage. You are also entitled to have the goods repaired or replaced if the goods fail to be of acceptable quality and the failure does not amount to a major failure.
4. The benefits given to you under this Kleenmaid Warranty are in addition to other rights and remedies to which you may be entitled under the Australian Consumer Law in relation to the Product to which this Kleenmaid Warranty relates. Subject to the conditions below, the Product is warranted by Kleenmaid and/or its agents to be free from defects in materials and workmanship for the Warranty Period for normal Domestic Use.
5. Product Identification: -
  - a. Kleenmaid reserves the right to reject claims for any services or work where you cannot produce for verification the serial number and a proof of purchase for the Product (including but not limited to the original invoice).
  - b. this Kleenmaid Warranty will be voided if the serial number for the Product cannot be verified. This is not intended to exclude, restrict or modify any right or remedy to which you may otherwise be entitled under the consumer guarantee provisions of the Australian Consumer Law.
  - c. in the event that a request for repair is made against this Kleenmaid Warranty where the serial number for the Product cannot be verified or you cannot produce for verification a proof of purchase for the Product (including but not limited to the original invoice), the repairer will not carry out any repairs on the Product and you will be charged a service call-out fee.
6. What is covered by this Kleenmaid Warranty: -
  - a. the Product is covered for faulty workmanship or parts that have failed under normal Domestic Use.
  - b. Kleenmaid and/or its agents will determine by objective testing if there are any defects in the Product and/or faulty workmanship.
  - c. this Kleenmaid Warranty is only applicable if repairs on Products are carried out within Mainland Australia.
  - d. this Kleenmaid Warranty: -
    - i. covers a Product purchased as new, manufactured for use in Mainland Australia;
    - ii. commences from the date of delivery of the Product;
    - iii. provides for the labour and replacement parts necessary to maintain the Product in good operating condition as specified in this Kleenmaid Warranty, however, if repair is needed because of Product failure during normal Domestic Use, Kleenmaid has the option to repair or replace the defective Product or part of the Product with a product or part of like kind and quality. A replacement part may be new or reconditioned of like kind and quality and may cost less than the original Product purchased and no charges or refunds will be made based on the replacement product or part cost difference; and
    - iv. is only applicable when the Product is used and operated in accordance with the Manufacturer's instructions.
7. What is not Covered by this Kleenmaid Warranty (excluded):-
  - a. any damage or failure to or of the Product or part of the Product:
    - i. due to the Product being inadequately serviced to manufacturer's recommendations;
    - ii. resulting from environmental conditions including and not limited to dirt, dust, rodents, insects, rust, corrosion, salt built-up, or of in any part of the Product;
    - iii. resulting from excessive use but fair wear and tear is excepted;
    - iv. resulting from installation by an unqualified or uncertified tradesperson;
    - v. resulting from poor or incorrect installation including and not limited to positioning and externally fitted equipment such as plumbing and drainage, cabling, antennae or due to incompatibility of connected equipment;
    - vi. caused by overheating as a result of sitting or positioning of the Product, where there is no provision for adequate ventilation or adequate protection from excessive dust;
    - vii. if the Product has been dismantled, repaired or serviced by any person other than someone authorised by Kleenmaid or its agents or representatives;
    - viii. caused by power surges or spikes, including and not limited to, mains power and telecommunications connections, or to other unspecified sources, incorrect power current, voltage fluctuation, amperage fluctuation, rust or corrosion;
    - ix. if the Product is dropped, collision of the Product with another object, use for which the Product is not designed, damage to the Product caused by your own negligence, accidental or deliberate misuse of the Product by you, theft, abuse, vandalism, flood, fire, earthquake, electrical storms or any other act of God or any war related events; or
    - x. due to the introduction of abnormal heat loads to the Product;
  - b. costs of attendance and testing where no fault or defect covered by the terms of this Kleenmaid Warranty is identified in the Product;
  - c. initial setup and installation of the Product;
  - d. normal maintenance costs and costs incurred through the installation of items listed as requiring periodic replacement;
  - e. Products with removed or altered serial numbers;
  - f. broken or cracked glass other than transport damage to the initial point of delivery;
  - g. consumables such as but not limited to bulbs/globes, seals, filters, batteries and remote controls;
  - h. removal and reinstallation of an internal component not performed by an authorised Kleenmaid agent or representative or authorised service centre;
  - i. cosmetic or structural items; or
  - j. any failures due to interference from or with other products and/or sources.
8. This Kleenmaid Warranty ceases if: -
  - a. the Product ceases to carry the original manufacturer's serial number or is sold at an auction;
  - b. the Product is rented; or
  - c. there is failure to pay monies owing on invoices as a result of non-warranty work being carried out at the request of the end user as per point 16 below.

9. Service under this warranty may be limited by the area in which you live. Service to remote and regional areas may incur additional travel costs which will be payable by you. You will be advised of this at the time you make a claim and Kleenmaid arranges to attend your premises.
10. Neither Kleenmaid nor its representatives provide loan equipment under the terms of this Kleenmaid Warranty.
11. Any unauthorised access to the internal hardware of the Product will void this Kleenmaid Warranty.
12. Repair Notice: Products presented for repair may be replaced by refurbished Products of the same type rather than being repaired. Refurbished parts may be used to repair the Products.
13. Replacement items are "like for like" and is not "new for old" and does not indicate in any way that a faulty Product will be replaced with a new part or unit. "Like for like" may either be a quality checked, refurbished or reconditioned unit of the same or later batch of model/size/specifications
14. The cost of making a claim under this Kleenmaid Warranty is not covered by Kleenmaid, including any costs of transportation or travel expenses between your home and your nearest authorised service agent.
15. Kleenmaid accepts no liability for items that are lost, damaged, or stolen as a result of freight, transport or storage. If you are required to transport the Product to an authorised service centre, you must ensure that it is securely packed and insured.
16. On Public Holidays or other periods when regular business and wholesale operations are temporarily ceased, repairer availability and warranty response times may extend beyond the standard response times due to the unavailability of repairers and parts.
17. For any repair performed on a Product under this Kleenmaid Warranty where no fault can be found, or the item is deemed by Kleenmaid or an authorised agent, to be not faulty under this Kleenmaid Warranty, or the repair or fault is not covered under this Kleenmaid Warranty, a 'No Fault Found' fee is payable by you. Kleenmaid will advise you of this cost and seek your agreement to pay such costs before commencing such repairs.
18. Any repairs or services required that are outside the terms and conditions of this Kleenmaid Warranty can be carried out at your request at your cost (including where the Product has not been installed or set up correctly). Kleenmaid will always advise you of this cost and seek your agreement to pay such costs before commencing such repairs. A credit card may be required prior to the commencement of such services.
19. Extra charges will be payable by the customer should the Product not be readily accessible without special equipment, such as but not limited to cranes and lifts or should the Product be installed in a position that service access is blocked and/or repair work is not possible without uninstalling the Product to gain access.
20. You, the customer, may be entitled to purchase an extended warranty in respect of the Product. Any extended warranty will not be issued by Kleenmaid but by a third party. Any extended warranty services will be provided directly by the third party as principal and not as agent for Kleenmaid, under their extended warranty terms and conditions and not under this Kleenmaid Warranty.
21. To make a claim under this Kleenmaid Warranty, please have your proof of purchase and the serial number of the Product ready and call (02) 9310 1207 during business hours.
22. This Kleenmaid Warranty is given by:  
 Name: Compass Capital Services Pty Ltd ABN 96 138 214 525 trading as Kleenmaid  
 Business address: Level 2, Suite 3, 204 Botany Rd, Alexandria NSW Australia 2015  
 Telephone: (02) 9310 1207
23. Definitions:
  - a. **Australian Consumer Law** means the *Competition and Consumer Act 2010* (Cth).
  - b. **Domestic Use** means use of the Product for personal, domestic or household purposes.
  - c. **Kleenmaid** means Compass Capital Services Pty Ltd ABN 96 138 214 525 trading as Kleenmaid.
  - d. **Mainland Australia** means the following States and Territories of Australia: New South Wales, Victoria, South Australia, Western Australia, Queensland, Tasmania, Northern Territory, Australian Capital Territory.
  - e. **Product** means the appliance sold by Kleenmaid to you as evidenced by the original purchase invoice.
  - f. **Service Agent** means any independent service agent engaged by Kleenmaid to carry out any repair or service under this warranty.
  - g. **Warranty Period** means for domestic use and for Products purchased on or after 1 January 2019 the period of 60 months, otherwise 36 months. For non-domestic use 12 months or such alternative period as may be specified.

**UPDATE NOTICE:** This Kleenmaid Warranty is current as at 1 December 2022 but is subject to variation from time to time. For the latest version of the Kleenmaid Warranty, please see our website <https://kleenmaid.com.au/warranty/> or phone us on (02) 9310 1207.

## Other products available in the Kleenmaid range of appliances

---

- | Washing machines
- | Clothes dryers
- | Dishwashers
- | Ovens
- | Cooktops
- | Steam ovens
- | Microwave ovens
- | Built in espresso coffee machines
- | Rangehoods
- | Freestanding ovens
- | Refrigerators & Freezers
- | Beverage Serving Cabinets
- | Water Dispensers
- | Vacuum Cleaners

To register your warranty or make a warranty claim, scan this QR code:



Compass Capital Services Pty Limited  
trading as Kleenmaid  
ABN 96138214525

Level 2, 204 Botany Road Alexandria  
NSW 2015



Register your Kleenmaid  
Appliances Warranty  
[www.kleenmaidwarranty.com.au](http://www.kleenmaidwarranty.com.au)

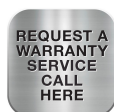

Request a Warranty Service  
[www.kleenmaidwarranty.com.au](http://www.kleenmaidwarranty.com.au)

E: [warranty@kleenmaid.com.au](mailto:warranty@kleenmaid.com.au)

Please download the current User Manual for this  
appliance at [www.kleenmaid.com.au](http://www.kleenmaid.com.au)

 **kleenmaid**