

# kitchen collection

---

Instructions for use and warranty details

To register your warranty or make a warranty claim, scan this QR code:



Beverage Serving Cabinet

Model No.: BSC4530

 **kLEENmaid**

Dear Customer,

Thank you and congratulations for choosing Kleenmaid.

Your new appliance has been designed and meticulously tested to ensure that it meets all your culinary requirements, and has been carefully manufactured using top quality materials to give you years of reliable performance.

For best results, carefully read the instructions on how your new appliance is to be installed. Correct installation will avoid delays and unnecessary service call costs.

Once installation is complete, please read this instruction manual carefully and get to know the controls and the features of your new Kleenmaid appliance. These simple instructions will enable you to achieve excellent results from the very first time you use it.

Again, congratulations and thank you for choosing The Best You Can Own.

KLEENMAID

# CONTENTS

Wine / Beverage Preservation Technology Warnings .....	4
Installation of Beverage Serving Cabinet. ....	7
General Instructions .....	7
Installation Drawings. ....	8
Installation Instructions .....	11
Instructions For Left Hinged Door Installation .....	12
Adjustable Timber Shelving .....	14
Switching On Your Beverage Serving Cabinet .....	15
Temperature Settings.. ....	17
Control Panel Instructions. ....	17
Auto Lighting Function .....	18
Replacing the LED Light Strip .....	19
Wine Serving Temperature Chart .....	20
Defrosting/Condensation/Hygrometry/Ventilation .....	21
Care and Cleaning .....	22
Replacing the Carbon Filter .....	22
Trouble Shooting .....	23
Trouble Shooting Guide .....	23
Specifications .....	25
Kleenmaid Warranty .....	26

# Wine / Beverage Preservation Technology

Before using this beverage serving cabinet, please read and follow all safety rules and operating instructions. The latest version of this manual is available on our website. (See back cover for details.)

## WARNING



CAUTION: Risk of fire

WARNING: When positioning the appliance, ensure the supply cord is not trapped or damaged.

WARNING: Do not locate multiple portable socket-outlets or portable power supplies at the rear of the appliance.

Warranty applies to the Beverage Serving Cabinet only and not to the content of the Beverage Serving Cabinet. The appliance is not covered by the warranty if it is being used for any purpose other than that for which it was specifically designed. We cannot be held responsible for any error in this manual, nor be responsible or liable for any spoilage or damage to wines or any other contents incidental or consequential to possible defects of the Beverage Serving Cabinet.

This appliance is not intended for use by persons (including children) with reduced physical, sensory or mental capabilities, or lack of experience and knowledge, unless they have been given supervision or instruction concerning use of the appliance by a person responsible for their safety. Cleaning and user maintenance should not be made by children without supervision. Children should be supervised to ensure that they do not play with the appliance.

This appliance has been designed exclusively for storing wine in a domestic environment. Any other usage is considered inappropriate. It should not be used in a commercial environment.

Only wine should be stored inside the appliance. Do not store food or other perishable items inside this beverage serving cabinet.

Do not put acidic items, flammable and explosive goods or similar into this beverage serving cabinet.

This appliance is intended to be used in household and similar applications such as

- staff kitchen areas in shops, offices and other working environments
- farm houses and by clients in hotels, motels and other residential type environments
- bed and breakfast type residential environments

The cabinet and its hinges and associated parts are designed to support the weight of the door only, and any damage to the door or its hinges or associated parts which is caused by excessive weight of any kind being placed or hung on the door will not be covered by warranty. The full cost of any warranty service call regarding damage which is assessed to be the result of excessive weight of any kind being placed onto the door will be for the care of the owner.

Children should specifically be prevented from climbing or swinging on the cabinet door. The appliance should never be lifted or moved by holding the door handle, and it is recommended that the door be removed before lifting or moving the cabinet.

**DANGER: Risk of child entrapment. Before you discard your old beverage serving cabinet:**

- Take off the doors
- Leave the shelves in place so that children may not easily climb inside
- When disposing of the appliance, do so only at an authorized waste disposal centre.

## **R600a Refrigerant WARNINGS:**

For your safety observe the following recommendations.

- This appliance contains a small quantity of R600a refrigerant which is environmentally friendly, but flammable. It does not damage the ozone layer, nor does it increase the greenhouse effect.
- During transportation and installation, ensure that the tubing of the refrigerant circuit is not damaged.
- Avoid using or manipulating sharp objects near the appliance.
- Leaking refrigerant can ignite and may damage the eyes.
- In the event any damage does occur, avoid exposure to open fires and any device which creates a spark. Disconnect the appliance from the mains power.
- Thoroughly ventilate the room in which the appliance is located for several minutes.
- Notify Customer Service for necessary action and advice.
- The area for installing the appliance must be at least 1 cubic metre per 8 grams of refrigerant. The refrigerant quantity contained in this appliance is listed in the Specifications table at the end of this document. It is also noted on the Rating Plate of the appliance.

**It is hazardous for anyone other than an Authorised Service Person to carry out servicing or repairs to this appliance. In Queensland - the authorised Service Person MUST hold a Gas Work Authorisation for hydrocarbon refrigerants to carry out servicing or repairs where the gas system is being opened or charged.**

WARNING: This appliance is only suitable for Domestic use and should not be used in a commercial environment.

WARNING: Keep ventilation openings in the appliance enclosure or in the built-in structure clear of obstruction.

WARNING: Do not use mechanical devices or other means to accelerate the defrosting process. Only use methods recommended by the manufacturer.

WARNING: Do not damage the refrigerant circuit.

WARNING: If the machine is not to be used for a lengthy period, please unplug the power plug from the socket or switch off the power supply.

WARNING: This appliance is not intended for use by persons (including children) with reduced physical, sensory or mental capabilities, or lack of experience and knowledge, unless they have been given supervision or instruction concerning use of the appliance by a person responsible for their safety;

WARNING: Children should be supervised to ensure that they do not play with the appliance.

WARNING: Do not use extension cords or ungrounded (two prong) adapters.

WARNING: If the supply cord is damaged, it must be replaced by the manufacturer, its service agent or similarly qualified person in order to avoid hazard.

WARNING: Do not use electrical appliances inside the storage compartments of the appliance, unless they are of the type recommended by the manufacturer.

WARNING: To avoid a hazard due to instability of the appliance, it must be fixed in accordance with the instructions.

## BEFORE LOADING & PLUGGING IN THE BEVERAGE SERVING CABINET

Allow 24 hours before switching on the beverage serving cabinet. During this time we recommend that you leave the door open to clear any residual odours.

**Important: BSC4530 is for integrated or built in use only.**

### Recommendations:

The location you have selected for your Beverage Serving Cabinet should:

- be unencumbered and well ventilated;
- be well away from any heat source and direct sunlight;
- not be too damp (laundry, bathroom etc.);
- have a standard and reliable electricity supply (standard AU earthed socket). Use of a power board or extension lead is not recommended.
- have a surge protector fitted to the electrical outlet.

The Beverage Serving Cabinet should be placed where the ambient temperature is within the range stated in the Specifications table at the end of this manual. If the temperature is above or below this range, it will affect the performance of the cabinet. Placing the cabinet in very cold or hot temperature conditions may cause the cabinet's temperature to fluctuate, and not maintain the ideal temperature.

### Grounding instructions:

The Beverage Serving Cabinet must be earthed in order for RCD safety switch to operate correctly and is required by law. Earthing reduces the risk of electrical shock. The Beverage Serving Cabinet is equipped with a power cord having an earthing wire and plug. The Beverage Serving Cabinet plug must be plugged into a properly affixed and earthed electrical outlet.

**Note:** In locations where there are frequent lightning storms, it is advisable to use surge protectors.

Improper use of the earthed plug can result in the risk of electric shock. Consult a qualified electrician or service person if the earthing instructions are not completely understood. If the supply cord is damaged, it must be replaced by a qualified person in order to avoid electrical hazard.



WARNING: IT MUST BE ENSURED THAT EACH APPLIANCE IS CONNECTED ONLY TO A 230VAC +10%/-6% 50Hz MAINS POWER SUPPLY WHICH CONTINUOUSLY COMPLIES WITH THE RELEVANT AUSTRALIAN STANDARD. FAILURE TO DO SO MAY SERIOUSLY DAMAGE THE APPLIANCE AND ANY SUCH DAMAGE IS NOT COVERED BY THE MANUFACTURER'S WARRANTY.



## INSTALLING YOUR BEVERAGE SERVING CABINET

**NOTE: Before making preparations for or commencing installation, the installer should refer to the current online version of the User Manual, which is available on the Kleenmaid website (see back cover for details).**

Unpack and remove all of the protection and adhesive strips from the packaging around and inside the Beverage Serving Cabinet. Retain the accessories bag and any other cabinet parts for use by the installer.

The Beverage Serving Cabinet must be positioned so that the plug is accessible. Release the power cord. Move your Beverage Serving Cabinet to its final location. The Beverage Serving Cabinet should be installed in a suitable place where the compressor will not be subject to physical contact.

**Leveling your Beverage Serving Cabinet:** The base of the cabinet in which the Beverage Serving Cabinet is installed must be level so the BSC4530 is level BEFORE loading wine.

### GENERAL INSTRUCTIONS

1. Built in Beverage Serving Cabinets are front venting but are not designed to be fully integrated behind a joinery door.
2. Please follow the installation diagram when installing built-in Beverage Serving Cabinets. Observe the minimum installation dimensions, or it will affect the venting of the cabinet.
3. Built-in Beverage Serving Cabinets draw air from right of the ventilation frame and expel through left of the ventilation frame.
4. Built in Beverage Serving Cabinets have a power switch located on the control panel.
5. The Beverage Serving Cabinet requires a standard 230 volt/10 amp power point.
6. The power cord is 2.0m in length and is fixed on the right side at the back when looking from the front of the cabinet.
7. As with many appliances of today, the Beverage Serving Cabinet has sensitive electronic components which are susceptible to damage through lightning and electricity supply faults. It is therefore advisable to use a power surge protector to avoid problems of this nature.
8. When a wood door is installed an air vent must be provided on the door for built-in Beverage Serving Cabinets

In hot climate zones, an air vent or grid, with a minimum ventilation size of 200mm x 40mm MUST be cut out at the rear top of the back partitioning or at the top of either side of the partitioning, allowing cool fresh air full access to flow into the 30mm gap located at the rear of the cabinet.

This air vent or grid must not be opened on the same side as other appliances such as ovens or an area that is sealed and without access to fresh cool air. Failing to comply with the above specifications could result in voiding the Warranty.

## INSTALLATION DRAWINGS

**Note:** The appliance must be positioned so that the plug is accessible after installation.

### DIMENSIONAL DRAWINGS:

As BSC4530 is a built-in model inside a cabinet, the cabinet should have good ventilation space and no back panel, otherwise it will affect the functioning of the cabinet. (Installation drawing as below)

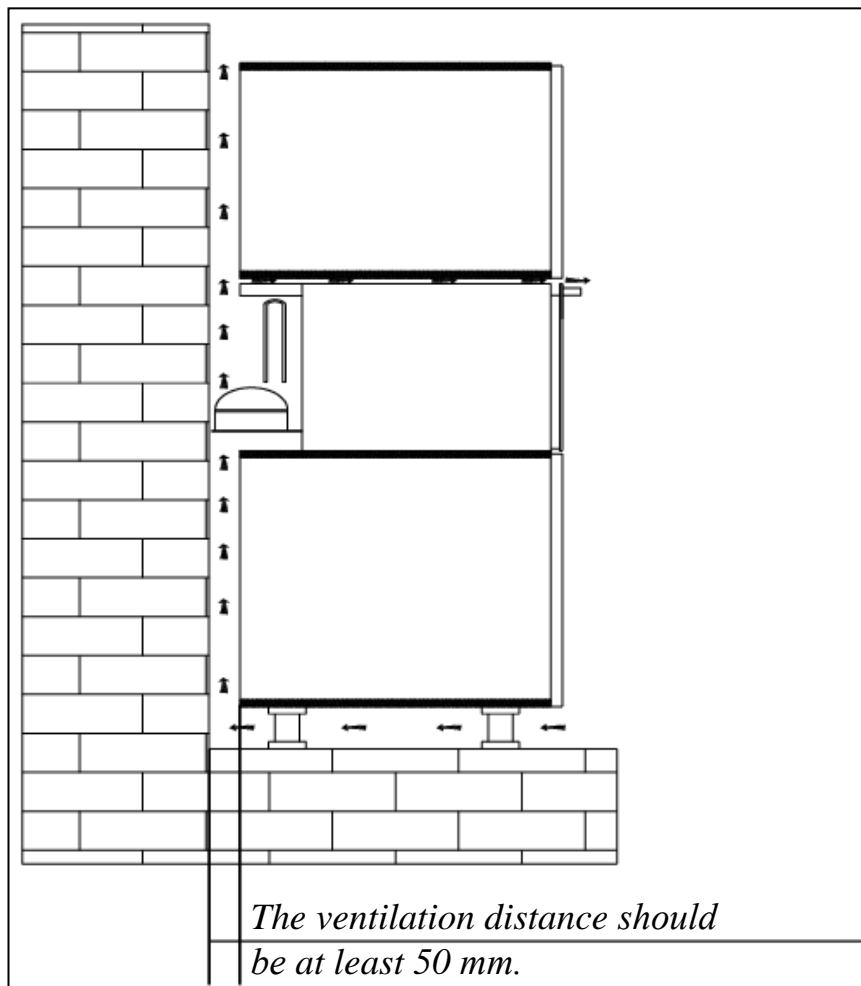



# INSTALLATION DRAWINGS

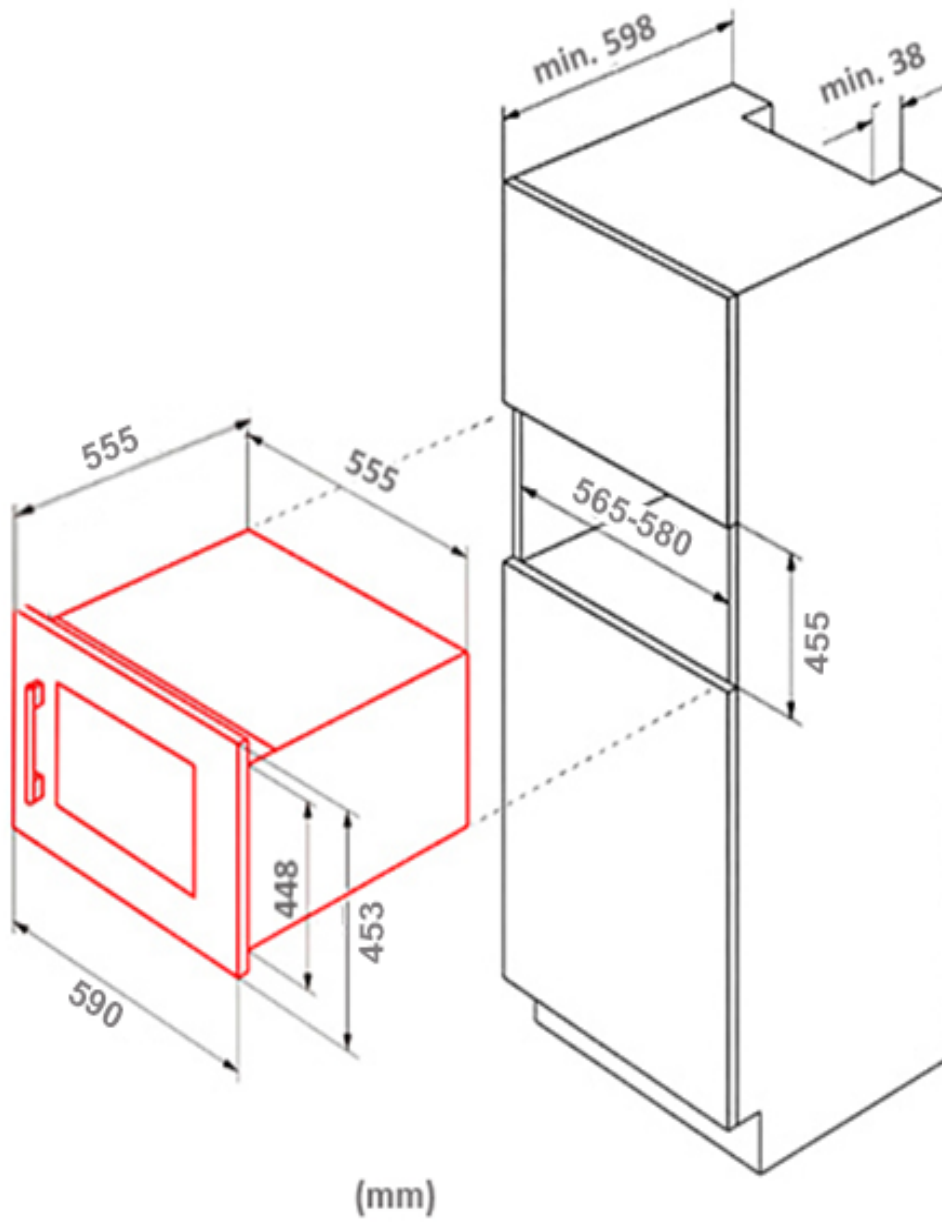

Note that the setback from the glass fascia to the niche front should be 20-22 mm.

# OPENING ANGLE

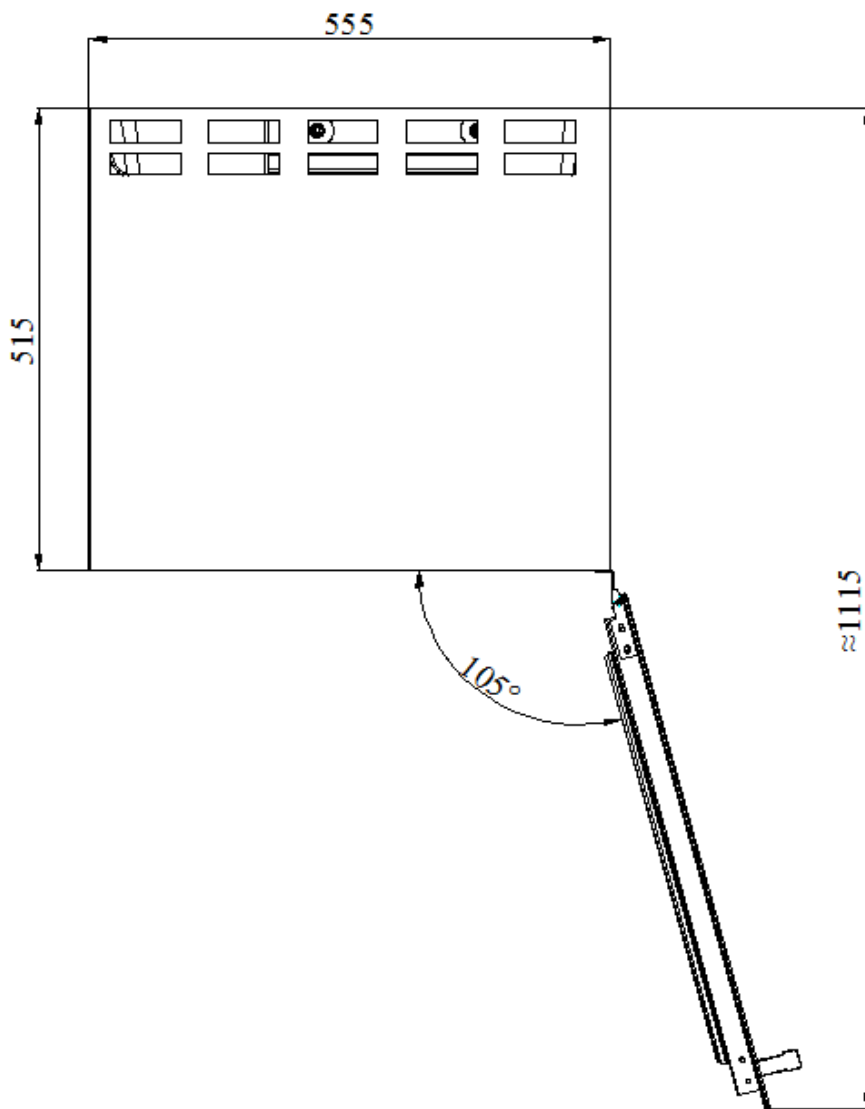

## Installation Instructions:

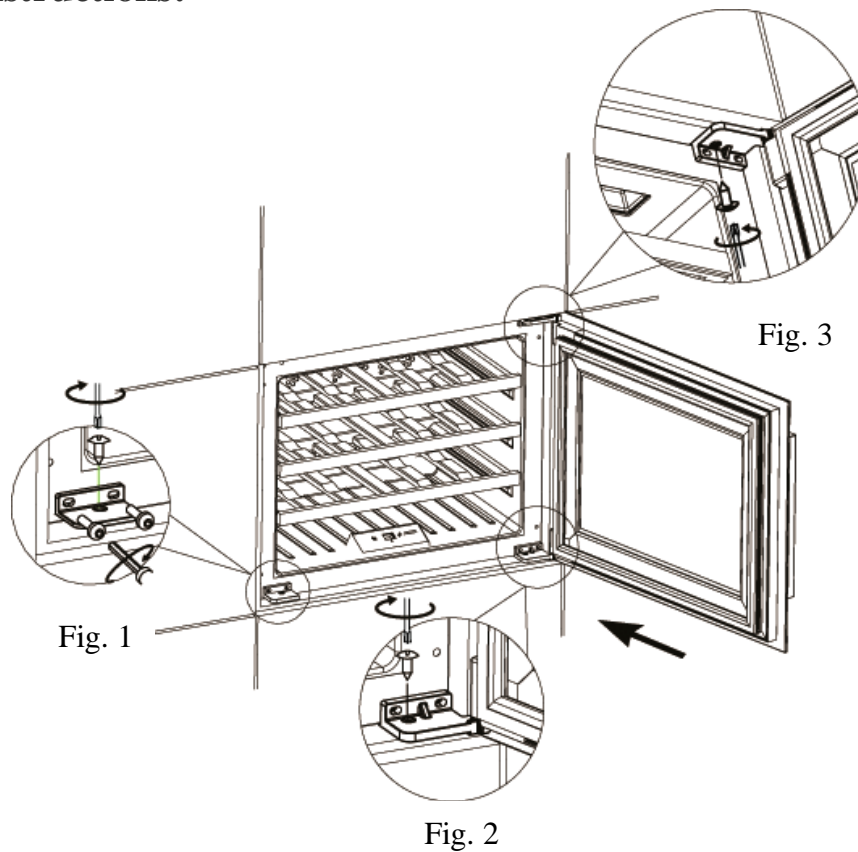

1. Place the Beverage Serving Cabinet into the cabinet, then adjust the beverage serving cabinet to make it steady. Note that the setback from the glass fascia to the niche front should be 20-22 mm. Open the door, take out the fixing plate (1 pcs), inner Hexagon Screws (2 pcs), inner Hexagon Screwdriver (1 pcs), and self-tapping screws (3 pcs) from the accessory bag.
2. Use the inner hexagon screwdriver to attach the fixing plate on the lower left side of the beverage serving cabinet with 2 inner Hexagon Screws (Fig.1).
3. Attach the fixing plate into the cabinet with 1pcs self-tapping screw (Fig.2).
4. Fix the other 2 pcs self-tapping screws into the cabinet through holes on the upper door hinge and lower door hinge (1 screw for each hinge) (Fig.2).

## INSTRUCTION FOR LEFT HINGED DOOR INSTALLATION

BSC4530 uses a replacement door kit for changing from the default right hand hinge to a left hand hinge. The Hinge Reversing Kit contains a complete new door WITHOUT a handle, which will be obtained from the original door, as will the black sensor magnet. The original door should be stored safely in case the hinge side is to be reversed again in the future. All other parts used for reversing the door are already supplied with the appliance.

### REMOVAL OF RIGHT HINGED DOOR

1. Unplug and place the beverage serving cabinet on an open work place.
2. Open the door to the maximum angle, undo the screws from upper hinge and lower hinge using a hexagon wrench, and remove the door. (See FIG.A and FIG.B.)
3. Use a Phillips head screwdriver to undo the screws on the door handle and, using these screws and screwdriver, attach the handle to the new left hinged door.
4. Use a Phillips head screwdriver to undo the two screws on the black sensor magnet and, using these screws and screwdriver, attach the magnet to the new left hinged door in the same location.

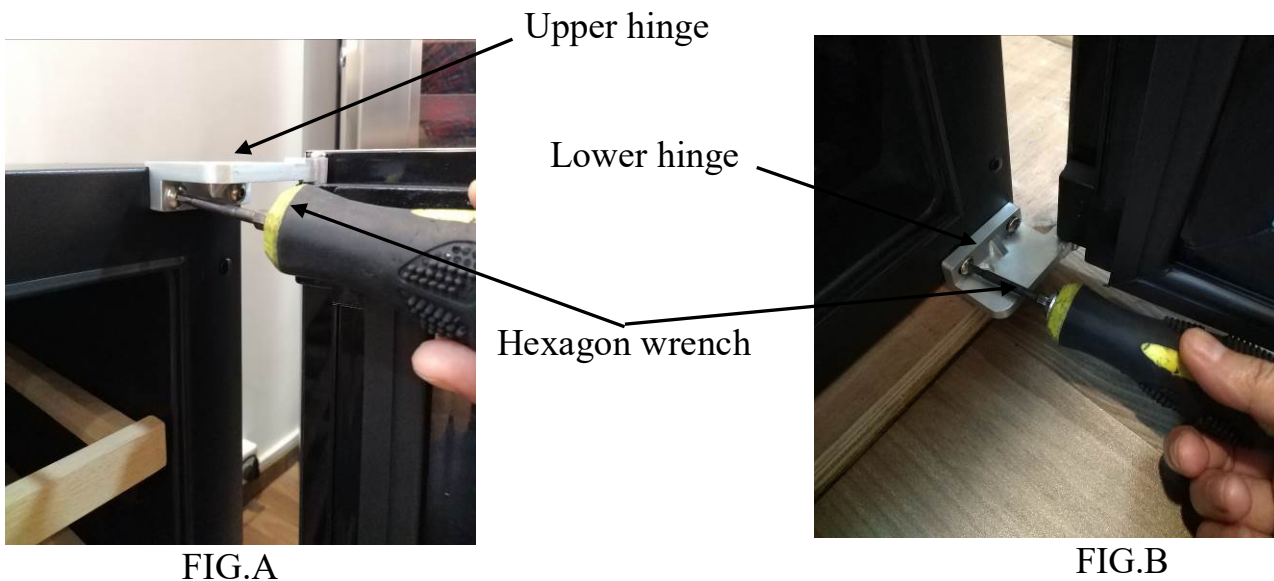

## INSTRUCTION FOR LEFT HINGED DOOR INSTALLATION

1. Take off the decorative plugs from the left sides (picture FIG.A and FIG.B).

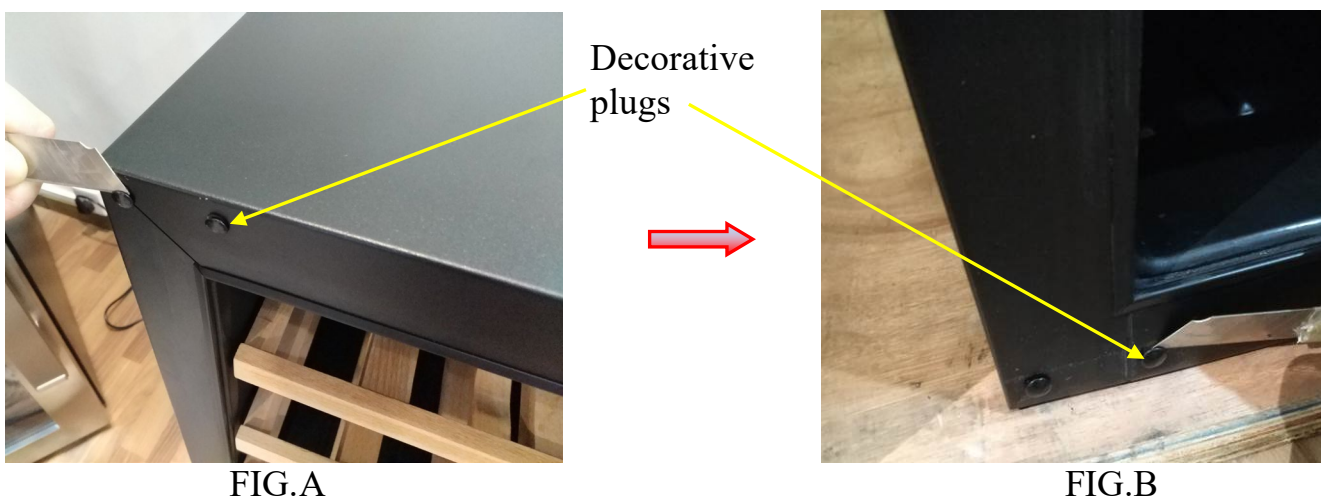

2. Align and install the upper and lower hinges to the hinge holes (picture FIG.C, FIG.D, FIG.E, and FIG.F)



FIG.C



FIG.D



FIG.E



FIG.F

3. Install door to the hinges (picture FIG.G , FIG.H, FIG.I)



FIG.G



FIG.H

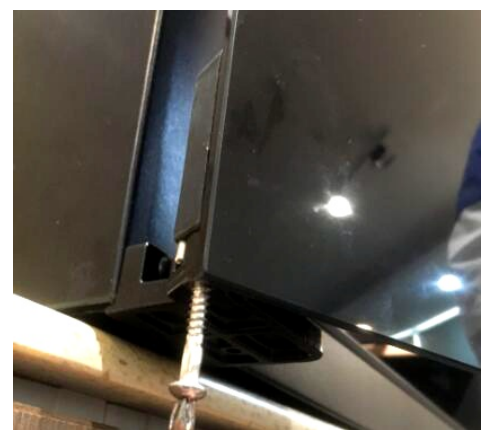

FIG.I

4. Cover the right hinge holes with decorative nails (picture FIG.J , FIG.K), complete the installation.



FIG.J



FIG.K

## ADJUSTABLE WOODEN SHELVES

### Adjusting & removing the shelves

For easy access to the storage content, you must pull the shelf approximately 1/3 of its depth out of the rail compartment. These beverage cabinets, however, are designed with a notch on each side of the shelf tracks to prevent bottles from falling.

When removing any of these shelves out of the rail compartment, tilt the shelf as per the diagram and simply pull out, or push in the shelf until it sits on the support brackets securely.

### Sliding wooden shelf installation and removal instruction:

1. Shelf removal: According to the instruction drawing below, pull out the shelf to support bracket ①, press two sides of sliding roller buckles and pull out the shelf following the arrow mark ②.

2. Shelf installation: According to the instruction drawing below, push in the shelf alignment with two sides of sliding roller following the arrow mark ③.

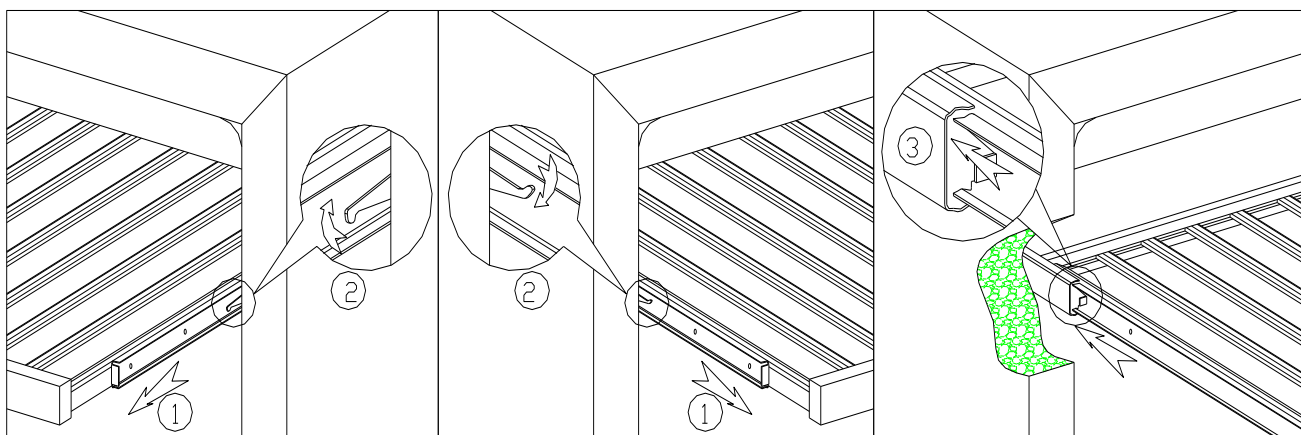

## **SWITCHING ON YOUR BEVERAGE SERVING CABINET**

Plug in and switch on the Beverage Serving Cabinet by pressing the power button **for 3 seconds**.

When you use the Beverage Serving Cabinet for the first time (or restart the Beverage Serving Cabinet after having it switched off for an extended period), there will be a few degrees variance between the temperature you have selected and the one indicated on the LED readout. This is normal and after the Beverage Serving Cabinet has run for a few hours it will stabilise at the set temperature

***Important: If the unit is unplugged, power is lost, or turned off, wait 3 to 5 minutes before restarting the unit. The Beverage Serving Cabinet will not start if you attempt to restart before this time delay.***

### **Operating Noises**

To reach the desired temperature settings, the Beverage Serving Cabinets, like all Beverage Serving Cabinets operating with compressors and fans, may produce the following types of noises. These noises are normal and may occur as follows:

- Gurgling sound - caused by the refrigerant flowing through the appliance's coils.
- Cracking/popping sounds - resulting from the contraction and expansion of the refrigerant gas as it varies in temperature.
- Fan operating sound - to circulate the air within the Beverage Serving Cabinet.

*An individual's perception of noise is directly linked to the environment in which the Beverage Serving Cabinet is located. This Beverage Serving Cabinets is in line with international standards for such appliance.*

## **LOADING YOUR BEVERAGE SERVING CABINET**

You may load your wine bottles in single or double rows while taking note of the following:

- If you do not have enough bottles to fill your Beverage Serving Cabinet, it is better to distribute the load evenly throughout the Beverage Serving Cabinet.
- Remove or relocate adjustable wooden shelves to accommodate larger type of bottles or increase the capacity of the cooler by stacking the bottles up when necessary. (See removing shelves page 14)
- Keep small gaps between the walls and the bottles to allow air circulation. Like an underground cellar air circulation is important to prevent mould and for a better homogeneous temperature within the cabinet.



- To facilitate air circulation DO NOT over load your Beverage Serving Cabinet or stack more than 1.5 rows of standard 0.75L bottles per shelf.
- Avoid obstructing the internal fans (located inside on the back panel of the Beverage Serving Cabinet).
- To prevent the bottles from falling DO NOT slide the shelves outwards beyond the fixed position.
- DO NOT pull out more than one loaded shelf at a time as this may cause the Beverage Serving Cabinet to tilt forward.
- DO NOT cover the timber shelves with aluminum foil or other materials, as it will obstruct air circulation.
- DO NOT move your Beverage Serving Cabinet while it is loaded with wines. This might distort the body of the Beverage Serving Cabinet or cause back injury.
- Only wine should be stored in this appliance. Food or other perishable items MUST NOT be stored inside this appliance.

## **TYPES OF REGULATION**

Please note that depending on the loading and settings chosen it takes about 24 hours for the Beverage Serving Cabinet temperature to stabilize.

During this time the LED in particular seems to move erratically. This is normal and this process occurs whenever the setting is modified and/or whenever a large amount of bottles are added to the cabinet.

Designed to store and mature all wines: red, white and sparkling, these Beverage Serving Cabinets reproduce the ideal conditions for wine storage, at a constant recommended temperature of 12°C. They can also be set to provide ideal serving temperature for full enjoyment of the wine's qualities. Unless stated by the wine maker on the bottle, temperatures of 7°C for your champagne, 12°C for whites and 18°C for reds are recommended. (Refer to "Wine Service Temperature" recommendation chart page 20)



## TEMPERATURE SETTINGS

***Important: The LED displays by default the actual internal air temperature.***

In the event of a power failure the settings are stored so when power is restored operation will resume with the previous settings.

It is important to understand that there is a difference between the air temperature inside the Beverage Serving Cabinet and the actual temperature of the wine. You will need to wait approximately 12 hours before noticing the effects of temperature adjustment due to the critical mass within a full Beverage Serving Cabinet.

Once the temperature is set, it is strongly advised not to adjust it too frequently. The thermostat will maintain the temperature inside the Beverage Serving Cabinet within a  $\pm 2.5^{\circ}\text{C}$  range, but the thermal inertia of the wine and the glass is such that within this temperature range, the actual temperature of the wine will only fluctuate  $0.5^{\circ}\text{C}$  to  $1^{\circ}\text{C}$ .

### Control Panel Instructions

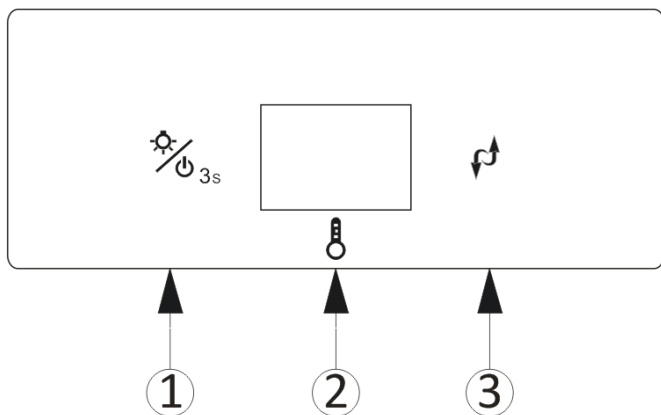

➤ ①  **Cycle Button:**

In standby mode: press and hold for 3 seconds, power is turned on, the machine starts

In the boot state: short press this button, LED lights on / off switch

In the boot state: press the button for 3 seconds, the power is off, the whole machine is closed.

➤ ②  **Display Window:**

Display the measured temperature inside the wine cooler

➤ ③  **Cycle Button:**

Each time the button is pressed the temperature inside will drop 1 °C, until reduced to a minimum, and then return to the highest temperature.

## **AUTO LIGHTNING FUNCTION**

This product is designed with auto lightning function (as default feature) , i.e.:

Auto lighting on when door opened.

Auto lighting off when door closed.

1. To keep lighting on even when door closed:

A. Open the door (lighting on)

B. Manually touch the lighting icon on the control panel once, then the permanently on lighting is effective.

C. Light will remain on when door is closed

2. To resume Auto lighting function:

A. Open the door (lighting on)

B. Manually switch off the light by touch the lighting icon on the control panel once, then the permanently on lighting is canceled.

C. Auto lighting off when door closed (Auto lighting function resumed).

## REPLACING THE LED LIGHT STRIP

1. Take out the LED light strip together with the light cover by unscrewing the screw in the middle.

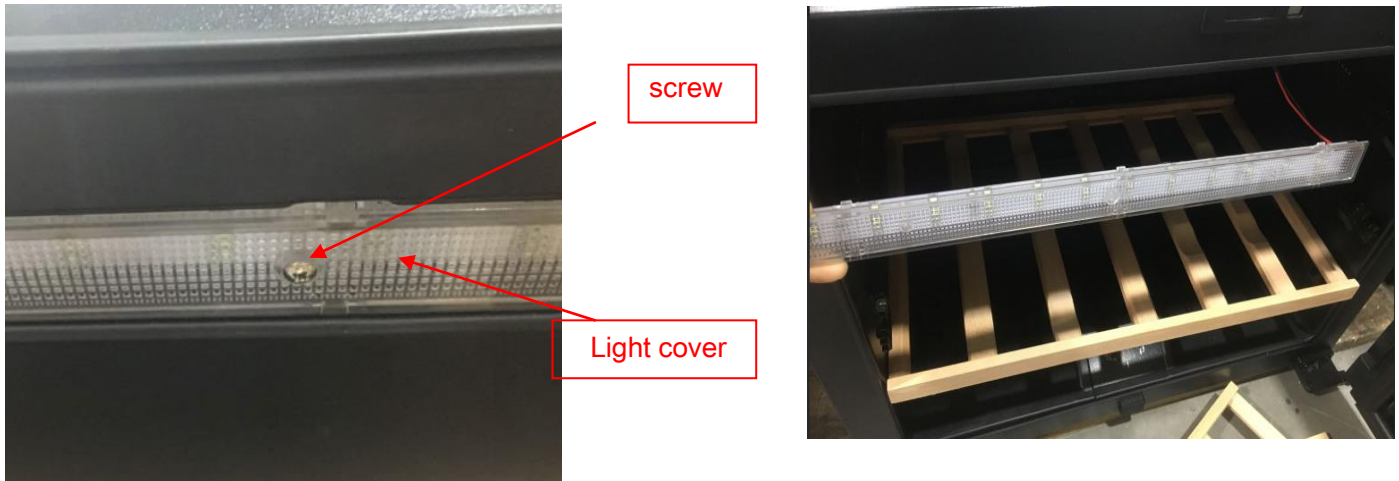

2. Unplug the LED light wire from the connector

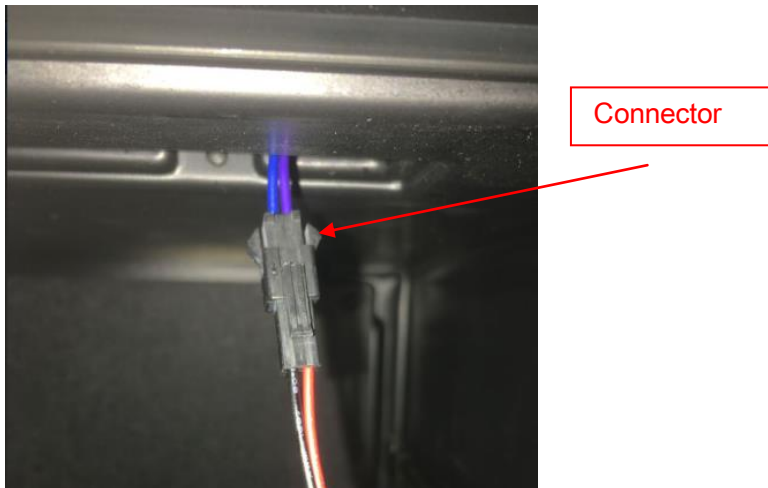

3. Take out the LED light strip from the light cover by unscrewing 2 screws on the strip

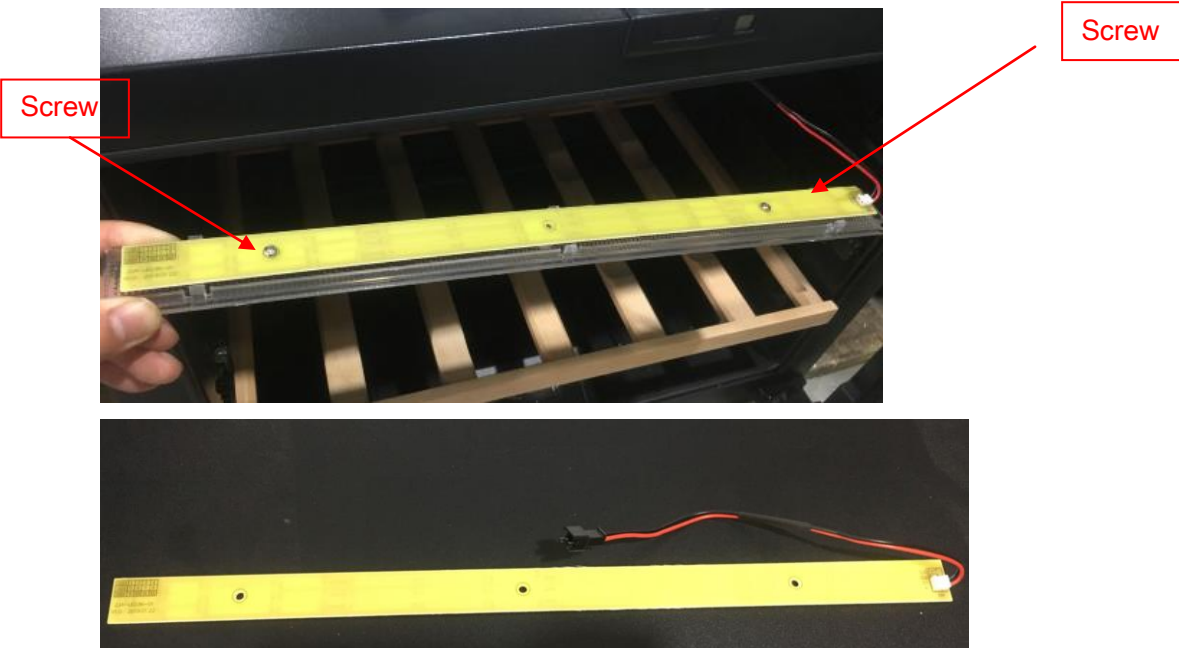

4. Replace the LED light strip by following these steps in reverse order.

## WINE SERVING TEMPERATURE CHART

All wines mature at the same temperature, which is a constant temperature set between 12°C to 14°C. The chart below is an indicative temperature chart to suggest the best temperature for drinking purposes.

Champagne NV, Sparkling, Spumante	6°C
Dry White Semillon, Sauvignon Blanc	8°C
Champagne Vintage,	10°C
Dry White Chardonnay	10°C
Dry White Gewürztraminer, Riesling, Pinot grigio	10°C
Sweet White Sauternes, Barsac, Montbazillac, Ice Wine, Late Harvest	10°C
Beaujolais	13°C
Sweet White Vintage: Sauternes...	14°C
White Vintage Chardonnay	14°C
Red Pinot Noir,	16°C
Red Grenache, Syrah	16°C
Red Vintage Pinot Noir	18°C
Cabernet & Merlot: French, Australian, New Zealand,	20°C
Chilean, Italian, Spanish, Californian, Argentinean...	
Vintage Bordeaux ...	Room temperature not exceeding 20°C

## IMPORTANT INFORMATION ABOUT TEMPERATURE

Your Beverage Serving Cabinet has been designed to guarantee optimum conditions for storing and/or serving your wines.

Fine wines require long and gentle developments and need specific conditions in which to reach their full potential.

All wines mature at the same temperature, which is a constant temperature set between 12°C to 14°C. Only the temperature of “dégustation” (wine appreciation) varies according to the type of wines (see “Wine Serving Temperature Chart” above). This being said and as it is for natural coolers used by wine producers for long period of storage, it is not the exact temperature that is important, but its consistency. As long as the temperature of your Beverage Serving Cabinet is constant (between 12°C to 14°C) your wines will be stored in perfect conditions.

Not all wines will improve over the years. Some should be consumed at an early stage (2 to 3 years) while others have tremendous ageing capability (50 and over). All wines have a peak in maturity. Please check with your wine merchant to get the relevant information.

## **DEFROSTING/CONDENSATION/HYGROMETRY/VENTILATION**

Your Beverage Serving Cabinet is designed with “Auto-cycle” defrost system. During “Off-cycle” the refrigerated surfaces of the Beverage Serving Cabinet defrost automatically. Defrost water from the Beverage Serving Cabinet storage compartment drains automatically and part of it goes into a drainage container, which is located at the back of the Beverage Serving Cabinet next to the compressor. The heat is transferred from the compressor and evaporates any condensation that has collected in the pan. Part of the remaining water is collected within the Beverage Serving Cabinet for humidity purposes. This system enables the creation of the correct humidity level inside your Beverage Serving Cabinet required by the natural cork to maintain a long lasting seal.

All units are equipped with a double glazed glass door that has a third internal acrylic layer to minimize condensation on the glass door. The space between the glass door panes is filled with an inert gas, Argon, to improve insulation and prevent condensation

The Beverage Serving Cabinet is not totally sealed; fresh air admission is permitted through the drainpipe. Air is circulated through the cabinet by means of a fan/fans and the hollow shelves.

**Note:** *During the refrigerating cycle, heat is given off and disperses through the external surfaces of the Beverage Serving Cabinet. Avoid touching the surfaces during those cycles.*

## CARE AND CLEANING

Always disconnect the appliance from the mains electrical supply before cleaning or performing maintenance.

- To remove/replace the timber shelves follow the instructions on page 14.
- Do not use abrasive products or detergents. After washing, rinse and dry thoroughly.
- The exterior of the appliance and the door seal should be cleaned using mild soapy water and dried thoroughly.
- The interior cabinet should be cleaned using a solution of bicarbonate of soda and lukewarm water.
- Clean the shelves separately by hand using mild soapy water. Do not put them in the dishwasher.
- Ensure that the cloth is only moist when cleaning the control panel and electrical parts, and all parts are completely dry before reconnecting the power.
- Once cleaning is complete, reconnect the mains electrical supply.
- If the appliance is not to be used for prolonged periods of time, unplug and clean the appliance thoroughly. The door should be left slightly ajar to prevent the formation of odours or condensation

### Replacing the Carbon Filter:

One carbon filter has been included for keeping air fresh by absorbing odours inside the wine cooler. It's recommended the carbon filter be replaced every 3-6 months.

### 3-How to replace a carbon filter:

1. Open the door and take out all shelves.
2. Take out the Carbon Filter Box by pulling firmly, replace the carbon filter pad inside the box, then replace the carbon filter box by pushing the box brackets into the two small mounting holes.

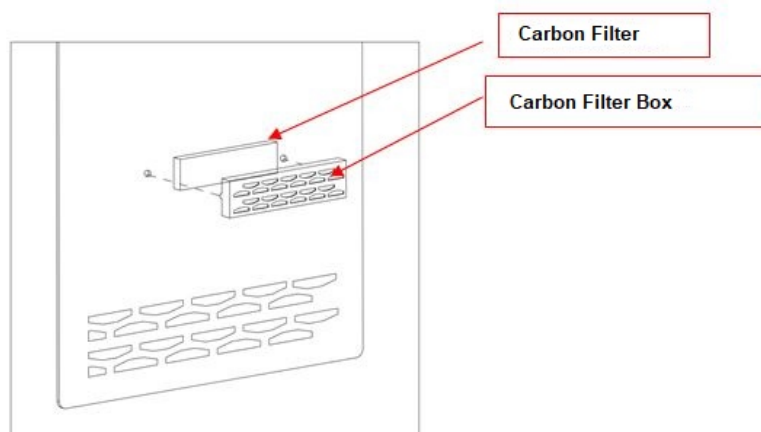

## **TROUBLE SHOOTING**

Ensure that there is power to the electrical supply plug by connecting another electrical appliance to it. Check fuse, if any. Make sure that the door is closed properly.

If your Beverage Serving Cabinet appears to be malfunctioning, unplug it and contact your after sales service. Any intervention on the cold circuit should be performed by a refrigeration technician who should carry out an inspection of the circuit sealing system. Similarly, any intervention on the electrical circuit should be performed by a qualified electrician.

**Notes:** *Any intervention performed by an unauthorised technician may lead to the warranty becoming void.*

## **POWER FAILURES**

In the event of a power interruption, all previous temperature settings are automatically preserved and the cabinet will revert to a preset temperature setting.

Most power failures are corrected within a short period of time. Loss of power for an hour or two will not affect the Beverage Serving Cabinet's temperatures. To avoid a sudden change of temperature while the power is off, you should not open the door. For a longer period of power failure, please take steps to protect your wine.

Regardless of the cause, if you notice either abnormal temperature or humidity levels inside your Beverage Serving Cabinet, be reassured that only long and frequent exposure to these abnormal conditions would have a detrimental effect on your wines, and normal operation of the appliance will stabilize these conditions.

## TROUBLE SHOOTING GUIDE

Common problems may easily be solved, saving you the possible cost of a service call. Please read the instruction manual carefully and consult this trouble shooting guide chart.

<b>PROBLEM</b>	<b>POSSIBLE CAUSE</b>
Beverage Serving Cabinet does not operate.	Not plugged in. The appliance is turned off. The circuit breaker tripped or the fuse is broken.
Beverage Serving Cabinet is not cold enough.	Check the temperature control setting. External environment may require a higher setting. The door is opened too often. The door is not closed completely. The door gasket does not seal properly.
Turns on and off frequently.	The room temperature is hotter than normal. A large amount of contents has been added to the Beverage Serving Cabinet. The door is opened too often. The door is not closed completely. The temperature control is not set correctly. The door gasket does not seal properly.
The light does not work.	Not plugged in. The circuit breaker tripped or a blown fuse. The bulb is out of order. The light button is "OFF".
Vibrations.	Check to assure that the Beverage Serving Cabinet is level.
The Beverage Serving Cabinet seems to make too much noise.	The rattling noise may come from the flow of the refrigerant, which is normal. As each cycle ends, you may hear gurgling sounds caused by the flow of refrigerant in your Beverage Serving Cabinet. Contraction and expansion of the inside walls may cause popping and crackling noises. The Beverage Serving Cabinet is not level.
The door will not close properly.	The Beverage Serving Cabinet is not level. The door was changed and not properly installed. The gasket is faulty (magnet or rubber is spoiled). The shelves are out of position.

If the appliance fails to operate correctly during the warranty period please visit our website to request a warranty service (see back cover of this manual for details). When booking a service please provide your Model No: BSC4530, and the individual Serial Number of your appliance. This is found on the label inside the front right hand side of the cabinet, visible when the door is open.



**Specifications:**

- Compressor operated: R600a

- Rated voltage/frequency : 230V+10%/-6% 50/60Hz

- Automatic defrost

- Humidity : 65% RH +/-10% RH

- Black outer and inner finish

- Internal light

- Triple layers glass door

- Ambient operating temperature range SN ~ T (10-43 C)

- Refrigerant quantity contained 18gm

- UV filter door glass

- Glass door panes space filled with Argon to improve insulation and prevent condensation

- Active carbon air filter

# KLEENMAID WARRANTY

## TERMS AND CONDITIONS

1. Compass Capital Services Pty Ltd ABN 96 138 214 525 trading as Kleenmaid will provide parts and labour to you the customer as set out herein.
2. Kleenmaid's Products come with guarantees that cannot be excluded under the Australian Consumer Law. You are entitled to a replacement or refund for a major failure and for compensation for any other reasonably foreseeable loss or damage. You are also entitled to have the goods repaired or replaced if the goods fail to be of acceptable quality and the failure does not amount to a major failure.
3. The benefits given to you under this Kleenmaid Warranty are in addition to other rights and remedies to which you may be entitled under the Australian Consumer Law in relation to the Product to which this Kleenmaid Warranty relates. Subject to the conditions below, the Product is warranted by Kleenmaid and/or its agents to be free from defects in materials and workmanship for the Warranty Period for normal Domestic Use.
4. Product Identification: -
  - a. Kleenmaid reserves the right to reject claims for any services or work where you cannot produce for verification the serial number and a proof of purchase for the Product (including but not limited to the original invoice).
  - b. this Kleenmaid Warranty will be voided if the serial number for the Product cannot be verified. This is not intended to exclude, restrict or modify any right or remedy to which you may otherwise be entitled under the consumer guarantee provisions of the Australian Consumer Law.
  - c. in the event that a request for repair is made against this Kleenmaid Warranty where the serial number for the Product cannot be verified or you cannot produce for verification a proof of purchase for the Product (including but not limited to the original invoice), the repairer will not carry out any repairs on the Product and you will be charged a service call-out fee.
5. What is covered by this Kleenmaid Warranty: -
  - a. the Product is covered for faulty workmanship or parts that have failed under normal Domestic Use.
  - b. Kleenmaid and/or its agents will determine by objective testing if there are any defects in the Product and/or faulty workmanship.
  - c. this Kleenmaid Warranty is only applicable if repairs on Products are carried out within Mainland Australia.
  - d. this Kleenmaid Warranty: -
    - i. covers a Product purchased as new, manufactured for use in Mainland Australia;
    - ii. commences from the date of delivery of the Product;
    - iii. provides for the labour and replacement parts necessary to maintain the Product in good operating condition as specified in this Kleenmaid Warranty, however, if repair is needed because of Product failure during normal Domestic Use, Kleenmaid has the option to repair or replace the defective Product or part of the Product with a product or part of like kind and quality. A replacement part may be new or reconditioned of like kind and quality and may cost less than the original Product purchased and no charges or refunds will be made based on the replacement product or part cost difference; and
    - iv. is only applicable when the Product is used and operated in accordance with the Manufacturer's instructions.
6. What is not Covered by this Kleenmaid Warranty (excluded):-
  - a. any damage or failure to or of the Product or part of the Product:
    - i. due to the Product being inadequately serviced to manufacturer's recommendations;
    - ii. resulting from environmental conditions including and not limited to dirt, dust, rodents, insects, rust, corrosion, salt built-up, of or in any part of the Product;
    - iii. resulting from excessive use but fair wear and tear is excepted;
    - iv. resulting from poor installation including and not limited to positioning and externally fitted equipment such as plumbing and drainage, cabling, antennae or due to incompatibility of connected equipment;
    - v. caused by overheating as a result of sitting or positioning of the Product, where there is no provision for adequate ventilation or adequate protection from excessive dust;
    - vi. if the Product has been dismantled, repaired or serviced by any person other than someone authorised by Kleenmaid or its agents or representatives;
    - vii. caused by power surges or spikes, including and not limited to, mains power and telecommunications connections, or to other unspecified sources, incorrect power current, voltage fluctuation, amperage fluctuation, rust or corrosion;
    - viii. if the Product is dropped, collision of the Product with another object, use for which the Product is not designed, damage to the Product caused by your own negligence, accidental or deliberate misuse of the Product by you, theft, abuse, vandalism, flood, fire, earthquake, electrical storms or any other act of God or any war related events; or
    - ix. due to the introduction of abnormal heat loads to the Product;
  - b. costs of attendance and testing where no fault or defect covered by the terms of this Kleenmaid Warranty is identified in the Product;
  - c. initial setup and installation of the Product;
  - d. normal maintenance costs and costs incurred through the installation of items listed as requiring periodic replacement;
  - e. Products with removed or altered serial numbers;
  - f. broken or cracked glass other than transport damage to the initial point of delivery;
  - g. consumables such as but not limited to bulbs/globes, seals, filters, batteries and remote controls;
  - h. removal and reinstallation of an internal component not performed by an authorised Kleenmaid agent or representative or authorised service centre;
  - i. cosmetic or structural items; or
  - j. any failures due to interference from or with other products and/or sources.
7. This Kleenmaid Warranty ceases if: -
  - a. the Product ceases to carry the original manufacturer's serial number or is sold at an auction;
  - b. the Product is rented; or
  - c. there is failure to pay monies owing on invoices as a result of non-warranty work being carried out at the request of the end user as per point 16 below.
8. Neither Kleenmaid nor its representatives provide loan equipment under the terms of this Kleenmaid Warranty.
9. Any unauthorised access to the internal hardware of the Product will void this Kleenmaid Warranty.

10. Repair Notice: Products presented for repair may be replaced by refurbished Products of the same type rather than being repaired. Refurbished parts may be used to repair the Products.
11. Replacement items are "like for like" and is not "new for old" and does not indicate in any way that a faulty Product will be replaced with a new part or unit. "Like for like" may either be a quality checked, refurbished or reconditioned unit of the same or later batch of model/size/specifications
12. The cost of making a claim under this Kleenmaid Warranty is not covered by Kleenmaid, including any costs of transportation or travel expenses between your home and your nearest authorised service agent.
13. Kleenmaid accepts no liability for items that are lost, damaged, or stolen as a result of freight, transport or storage. If you are required to transport the Product to an authorised service centre, you must ensure that it is securely packed and insured.
14. On Public Holidays or other periods when regular business and wholesale operations are temporarily ceased, repairer availability and warranty response times may extend beyond the standard response times due to the unavailability of repairers and parts.
15. For any repair performed on a Product under this Kleenmaid Warranty where no fault can be found, or the item is deemed by Kleenmaid or an authorised agent, to be not faulty under this Kleenmaid Warranty, or the repair or fault is not covered under this Kleenmaid Warranty, a 'No Fault Found' fee is payable by you. Kleenmaid will advise you of this cost and seek your agreement to pay such costs before commencing such repairs.
16. Any repairs or services required that are outside the terms and conditions of this Kleenmaid Warranty can be carried out at your request at your cost (including where the Product has not been installed or set up correctly). Kleenmaid will always advise you of this cost and seek your agreement to pay such costs before commencing such repairs. A credit card may be required prior to the commencement of such services.
17. Extra charges will be payable by the customer should the Product not be readily accessible without special equipment, such as but not limited to cranes and lifts or should the Product be installed in a position that service access is blocked and/or repair work is not possible without uninstalling the Product to gain access.
18. You, the customer, may be entitled to purchase an extended warranty in respect of the Product. Any extended warranty will not be issued by Kleenmaid but by a third party. Any extended warranty services will be provided directly by the third party as principal and not as agent for Kleenmaid, under their extended warranty terms and conditions and not under this Kleenmaid Warranty.
19. To make a claim under this Kleenmaid Warranty, please have your proof of purchase and the serial number of the Product ready and call (02) 9310 1207 during business hours.
20. This Kleenmaid Warranty is given by:
  - Name: Compass Capital Services Pty Ltd ABN 96 138 214 525 trading as Kleenmaid
  - Business address: Level 2, Suite 3, 204 Botany Rd, Alexandria NSW Australia 2015
  - Telephone: (02) 9310 1207
21. Definitions:
  - a. **Australian Consumer Law** means the *Competition and Consumer Act 2010* (Cth).
  - b. **Domestic Use** means use of the Product for personal, domestic or household purposes.
  - c. **Kleenmaid** means Compass Capital Services Pty Ltd ABN 96 138 214 525 trading as Kleenmaid.
  - d. **Mainland Australia** means the following States and Territories of Australia: New South Wales, Victoria, South Australia, Western Australia, Queensland, Tasmania, Northern Territory, Australian Capital Territory.
  - e. **Product** means the appliance sold by Kleenmaid to you as evidenced by the original purchase invoice.
  - f. **Warranty Period** means the period of 60 months for domestic use, 12 months for non-domestic use or such alternative period as may be specified.

**UPDATE NOTICE:** This Kleenmaid Warranty is current as at 1 January 2019 but is subject to variation from time to time. For the latest version of the Kleenmaid Warranty, please see our website <https://www.kleenmaidwarranty.com.au/> or phone us on (02) 9310 1207.

## Other products available in the Kleenmaid range of appliances

---

- | Washing machines
- | Clothes dryers
- | Dishwashers
- | Ovens
- | Cooktops
- | Steam ovens
- | Microwave ovens
- | Built in espresso coffee machines
- | Rangehoods
- | Freestanding ovens
- | Refrigerators & Freezers
- | Beverage Serving Cabinets
- | Water Dispensers
- | Vacuum Cleaners

To register your warranty or make a warranty claim, scan this QR code:



Compass Capital Services Pty Limited  
trading as Kleenmaid  
ABN 96138214525

Level 2, 204 Botany Road Alexandria  
NSW 2015



Register your Kleenmaid  
Appliances Warranty  
[www.kleenmaidwarranty.com.au](http://www.kleenmaidwarranty.com.au)

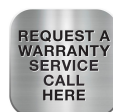

Request a Warranty Service  
[www.kleenmaidwarranty.com.au](http://www.kleenmaidwarranty.com.au)

E: [support@kleenmaid.com.au](mailto:support@kleenmaid.com.au)  
Please download the current User Manual for this  
appliance at [www.kleenmaid.com.au](http://www.kleenmaid.com.au)

 **kleenmaid**