

1.9349.02.X.IS / 1.9349.02.2.IS

WALL TAPS

INSTALLATION INSTRUCTIONS

IMPORTANT INFORMATION:

- For servicing the cartridge, isolate the water supply, remove the handle, remove the locknut from on top of the cartridge and remove the cartridge. Do not overtighten the locknut when reinstalling. The locknut should be tightened firmly, but not excessively.
- All tapware and plumbing must be tested for leaks and functionality before sheeting off / concealing the wall as per AS3500. This includes independently testing the hot and cold operation of the mixer.
- Water pressure must not exceed 500kpa as per AS3500, or the product warranty will be void.
- Pressure difference between hot and cold must not exceed 150kpa.
- This product is designed to work on high pressure systems only.
- Before sheeting the walls it is important that the system is checked for water hammer. If water hammer is apparent, all possible measures are to be taken, including but not limited to ensure pipework is correctly secured, keeping the length of the pipework from the outlet as short as possible, and the fitting of outlets which have a high star rating. Ensure that water pressure is not exceeding 500kpa, ensuring the correct pipe size is installed. Install an air chamber or water hammer arrestor if required.
- Ensure wall sheets and tiles are installed as close to the waterproofing sleeve as possible.
- Ensure waterproofing sleeve is not deformed. If the waterproofing sleeve is deformed by wall linings, the trim kit will not be able to be installed.
- Use of the provided insulation is optional. If the insulation is not used, Brodware recommend using another form of acoustic barrier around the body / breech.

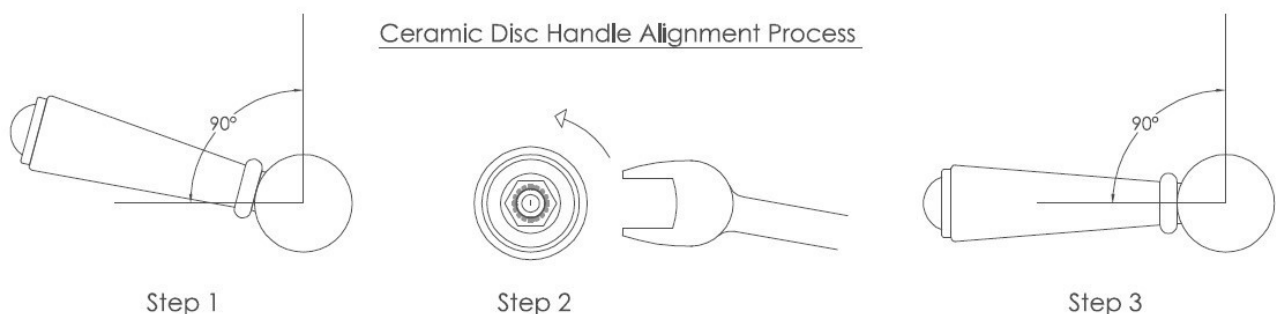

Step 1) Remove lock nut off spindle. Screw spindle into the tap body. Do not over tighten. Trial fit the handle first, to check the handle position. Step 2) If the handle is not sitting square, slightly tighten or slightly back off the spindle. You should not need to tighten or back off the spindle more than 1/16th of a rotation. Step 3) Once the handle is in the correct position, fit washer over spindle and screw down the lock nut using a 25mm or 1" tube spanner. Do not use multigrips

ROUGH IN PROCESS

1. Set-back for rough in of the breech assembly is 25mm – 32mm, from the face of the tap body of the breech assembly to the finished wall face (Fig.B). NOTE: If the optional 1.9305.BK.0.00 Adjustable Install Kit is being used, add 2mm to the set-back to accommodate the kit.
2. As per Fig. A, the hot inlet port is on the bottom left, the cold inlet port is on the bottom right, and the outlet port is on the far right. The breech assembly should always be installed with the outlet port on the far right.
3. Remove the insulation. Secure the assembly to a noggin in the desired installation location and position by screwing through the 4 black rubber bushes on each corner of the mounting plate. We suggest using a pan head screw with a loose washer (Fig.A).
4. Flush water Lines. Connect the hot and cold water feeds to the inlet ports on the breech assembly. Ensure the spindles and locknuts are fitted tight to the breech. Test as per AS3500. Check operation and test for leaks before plastering or tiling. (If water hammer is apparent, please refer to the "IMPORTANT INFORMATION" section of this instruction booklet)
5. Refit the insulation (optional – refer to the "IMPORTANT INFORMATION" section of this installation instruction). Ensure the waterproofing sleeve is screwed down fully over the o-ring to ensure a positive seal. Press the sleeve cap into the waterproofing sleeve (Fig. B).
6. Sheet the wall. Waterproof to the waterproofing sleeve. Waterproofing membrane should be applied on both sides of the waterproofing aid supplied. **NOTE: the waterproofing aid is optional for installation. Assess if this should be used on your installation. All waterproofing liability is with the installer.**
7. Finish concealing the wall.

FINAL FIT OFF PROCESS

1. Cut down the waterproofing sleeve flush with the finished wall face (Fig.D). Hold the waterproofing sleeve in position while cutting, to ensure that the waterproofing sleeve does not unscrew from inside the wall. Apply silicone between the waterproofing sleeve and the wall face.
2. Trial fit the cover plate, handles and handle spacers. If the spindles are too long, remove them and them down to the required length, then refit **(DO NOT CUT DOWN THE SPINDLES WHILST STILL IN THE BREECH ASSEMBLY)**.
3. Before fitting the cover plate, ensure that the handles aligned, by placing the handles onto the spindles. If the handles require aligning, please follow the procedure on previous page.
4. Fit the red fibre washer and locknuts to the spindles. Secure cover plate over the spindles. While pressing the cover plate firmly against the finished wall face, fit both handles and handle spacers to the spindles with the grub screws provided.
5. Apply thread tape to the male thread on the outlet thread and screw the bottom outlet elbow firmly back to the cover plate.
6. Test for leaks and functionality.

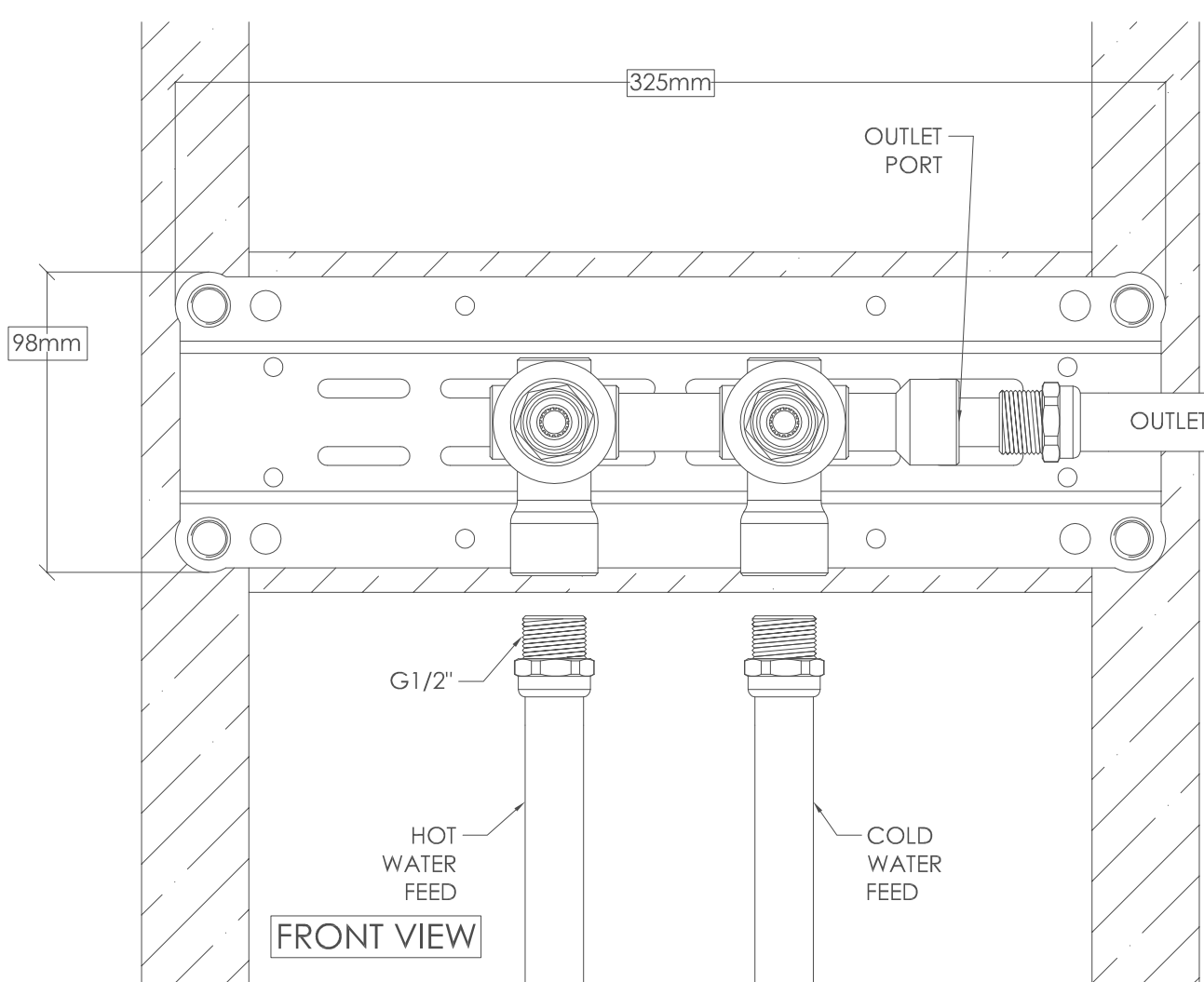

Fig.A

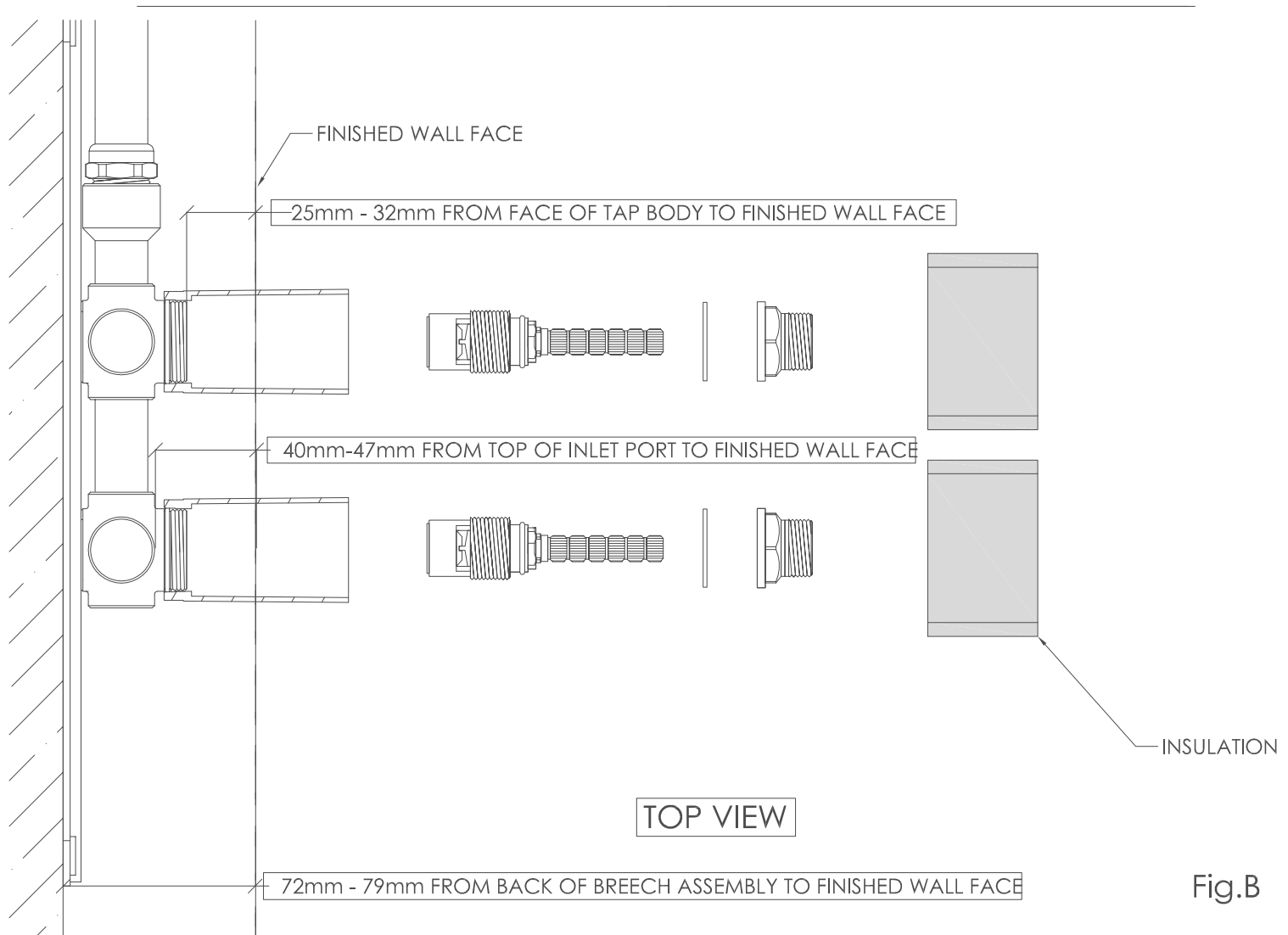

Fig.B

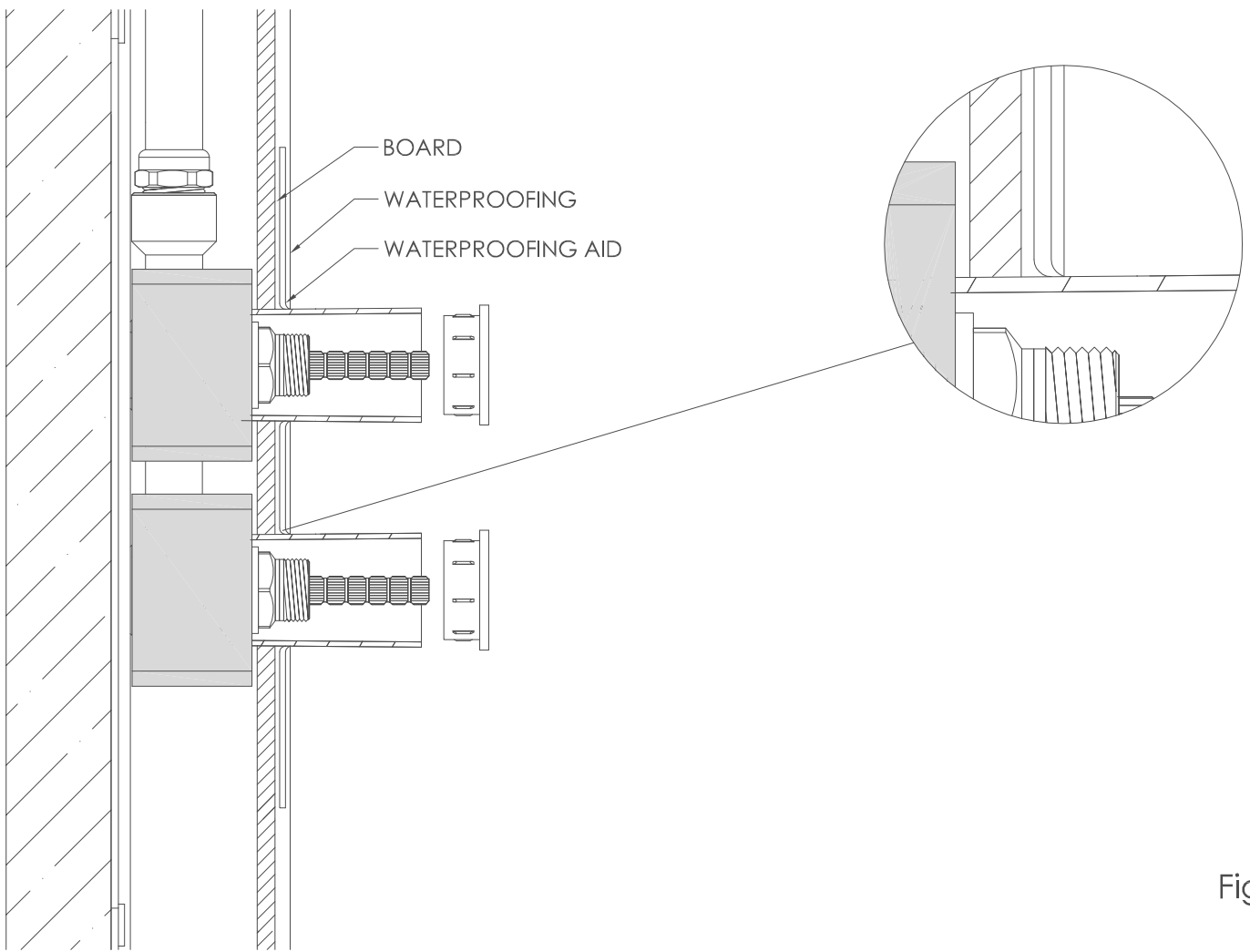

Fig.C

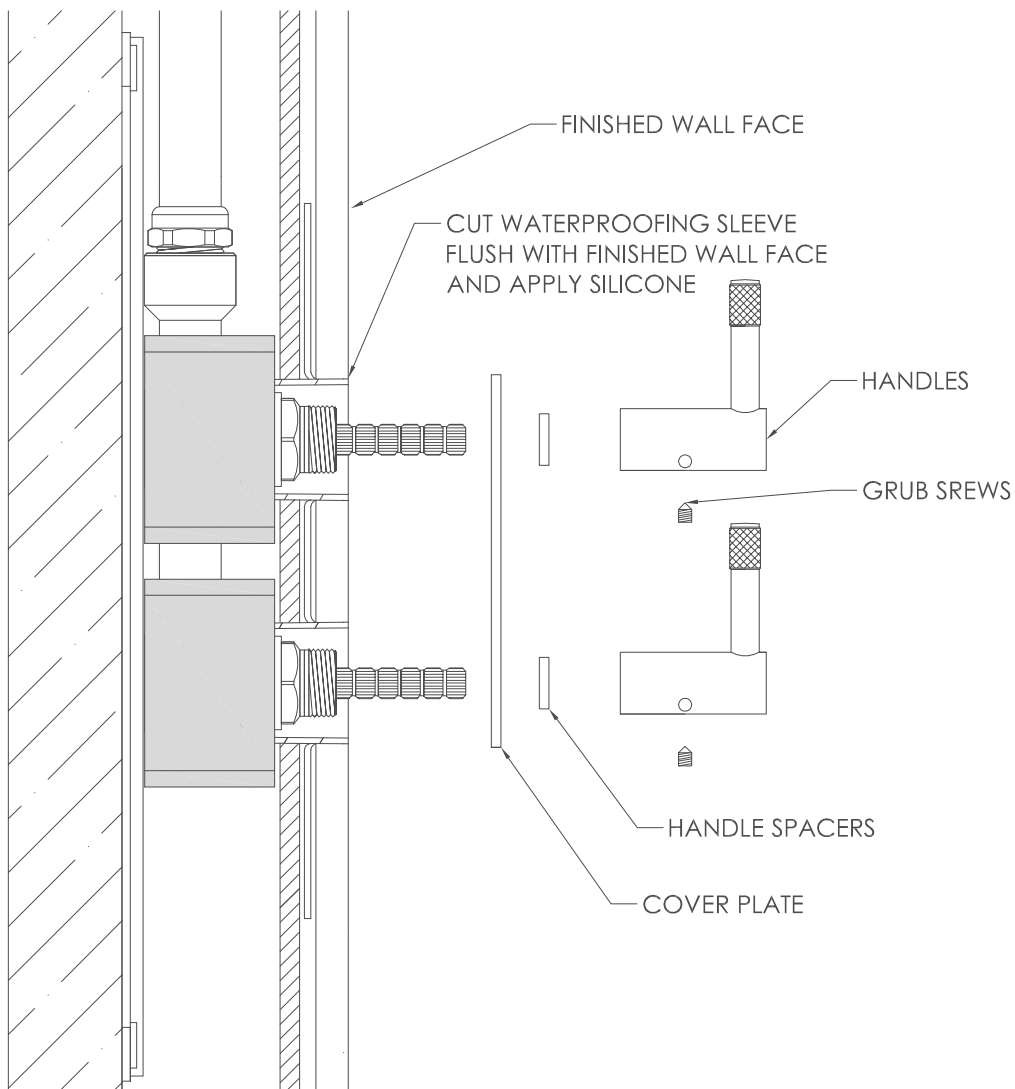

Fig.D