

# NANNUP ENTERTAINMENT UNIT

## 1400mm UNIT | SIZING GUIDE

### UNIT DIMENSIONS

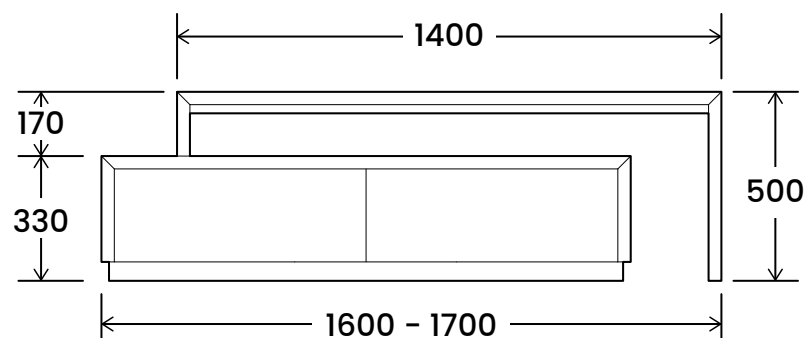

### 32" TV | 1400mm + 200mm

- For a 32" TV we would recommend not going smaller than a 1400mm unit.
- With a small extension of the riser the unit is made to be 1.6 times wider than the TV.
- Based on the golden ratio this size is the perfect balance between the size of the unit and the TV.
- This unit will allow you to upgrade your TV in the future with its ability to extend.

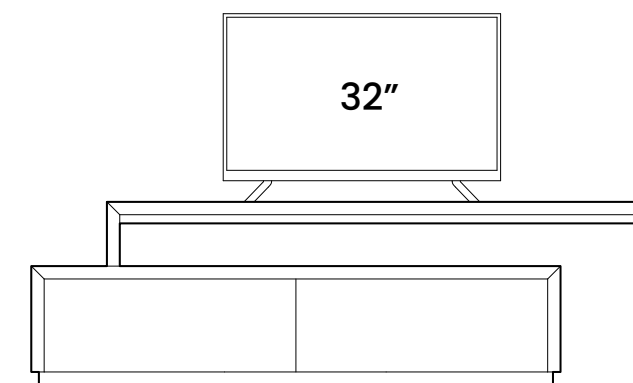

### 43" TV | 1400mm + 250mm

- As you upgrade your TV to a larger size the ability to extend the unit shows its potential.
- With a small extension of the riser the unit is made to be 1.6 times wider than the TV.
- Based on the golden ratio this size is the perfect balance between the size of the unit and the TV.
- This will allow you to keep the special items you have placed on your unit on display.

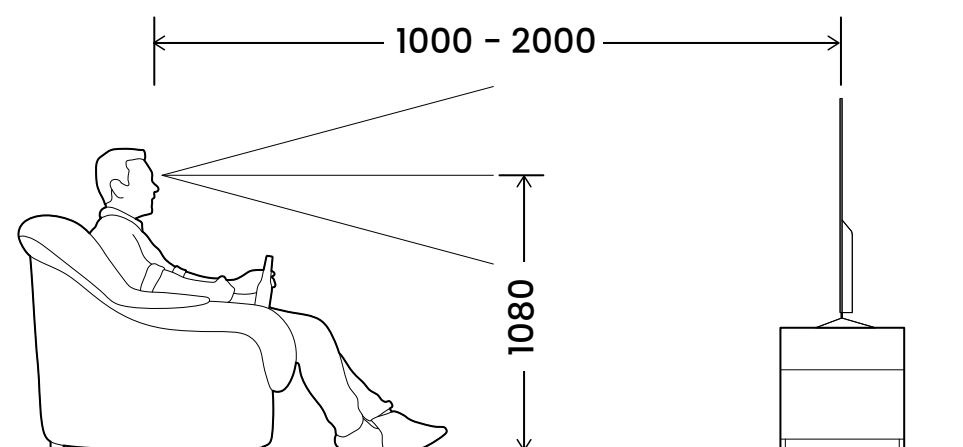
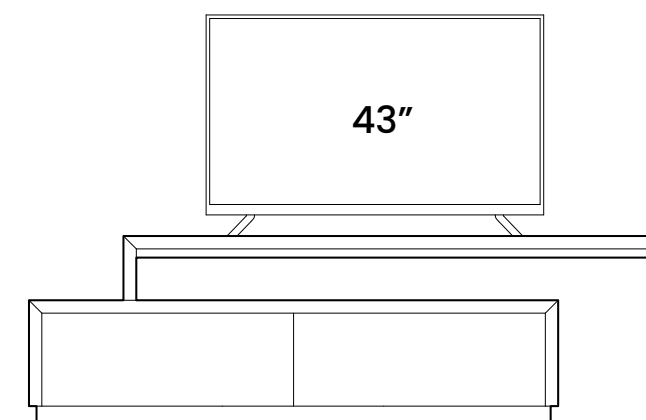

### NACO IDEAL TV SETUP GUIDELINES

- For an ideal TV viewing height make sure the TV center is at or just below your seated eye level.
- For most people a comfortable seated eye level height is around 1080mm from the ground.
- A TV's optimal viewing distance is calculated by multiplying the TV diagonal size by 1.5 times.
- For a 32 -50 inch TV an optimal viewing range is between 1000mm and 2000mm from the TV.

### 50" TV | 1400mm + 300mm

- As you upgrade your TV to a larger size the ability to extend the unit shows its potential.
- With a small extension of the riser the unit is made to be 1.6 times wider than the TV.
- Based on the golden ratio this size is the perfect balance between the size of the unit and the TV.
- This will allow you to keep the special items you have placed on your unit on display.

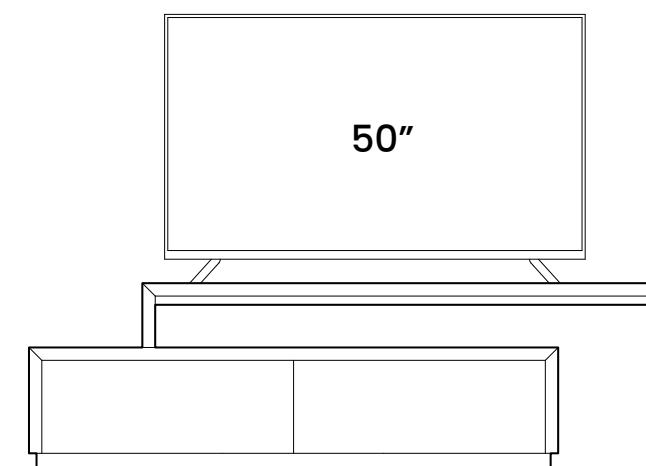

## NANNUP ENTERTAINMENT UNIT

### 1800mm UNIT | SIZING GUIDE

#### UNIT DIMENSIONS

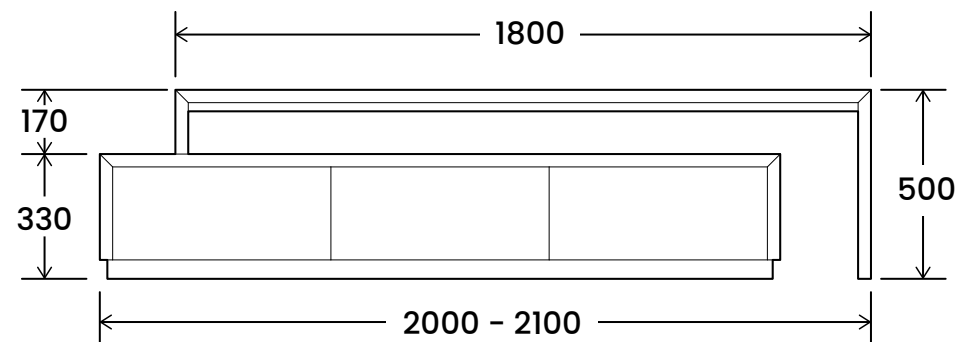

#### 50" TV | 1800mm + 200mm

- For a 50" TV we would recommend not going smaller than a 1800mm unit.
- With a small extension of the riser the unit is made to be 1.6 times wider than the TV.
- Based on the golden ratio this size is the perfect balance between the size of the unit and the TV.
- This unit will allow you to upgrade your TV in the future with its ability to extend.

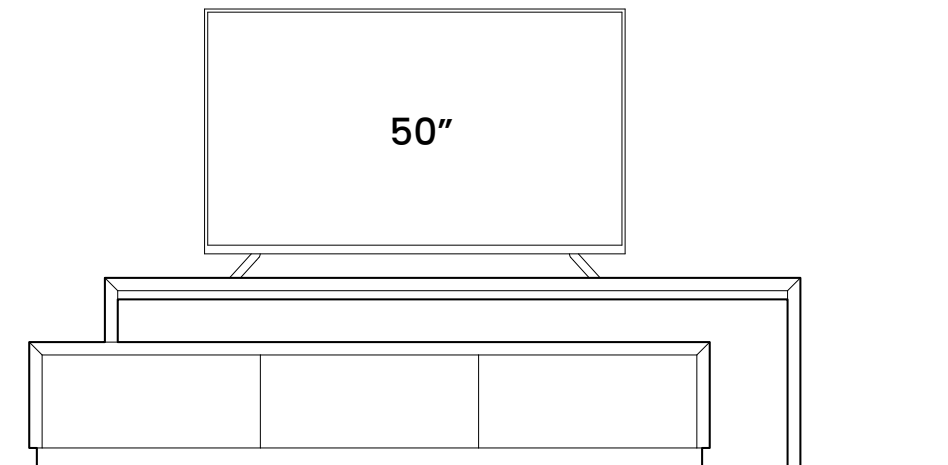

#### 55" TV | 1800mm + 250mm

- As you upgrade your TV to a larger size the ability to extend the unit shows its potential.
- With a small extension of the riser the unit is made to be 1.6 times wider than the TV.
- Based on the golden ratio this size is the perfect balance between the size of the unit and the TV.
- This will allow you to keep the special items you have placed on your unit on display.

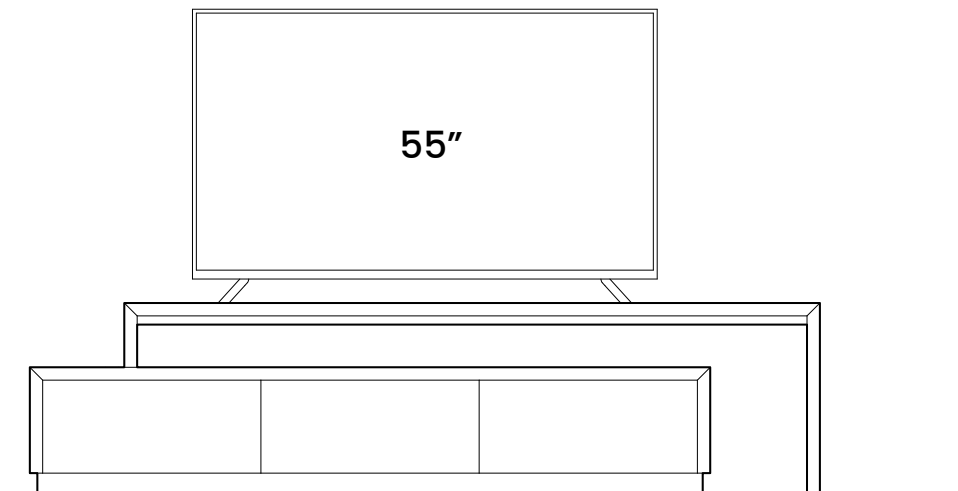

#### 65" TV | 1800mm + 300mm

- As you upgrade your TV to a larger size the ability to extend the unit shows its potential.
- With a small extension of the riser the unit is made to be 1.6 times wider than the TV.
- Based on the golden ratio this size is the perfect balance between the size of the unit and the TV.
- This will allow you to keep the special items you have placed on your unit on display.

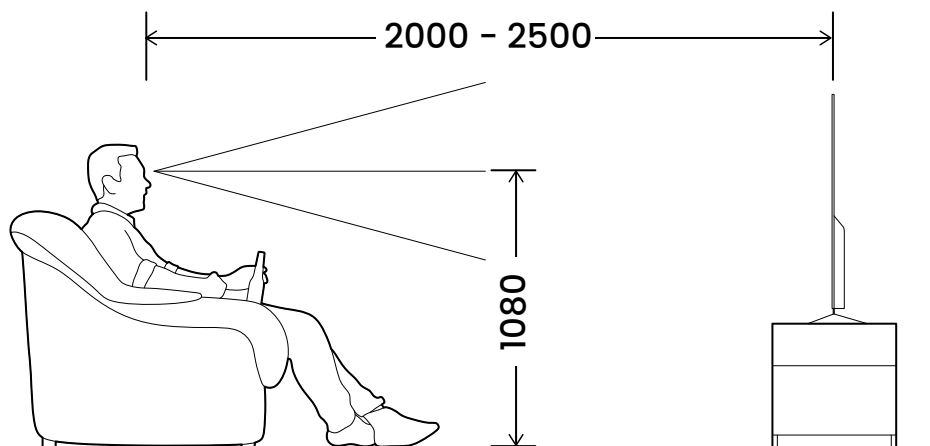
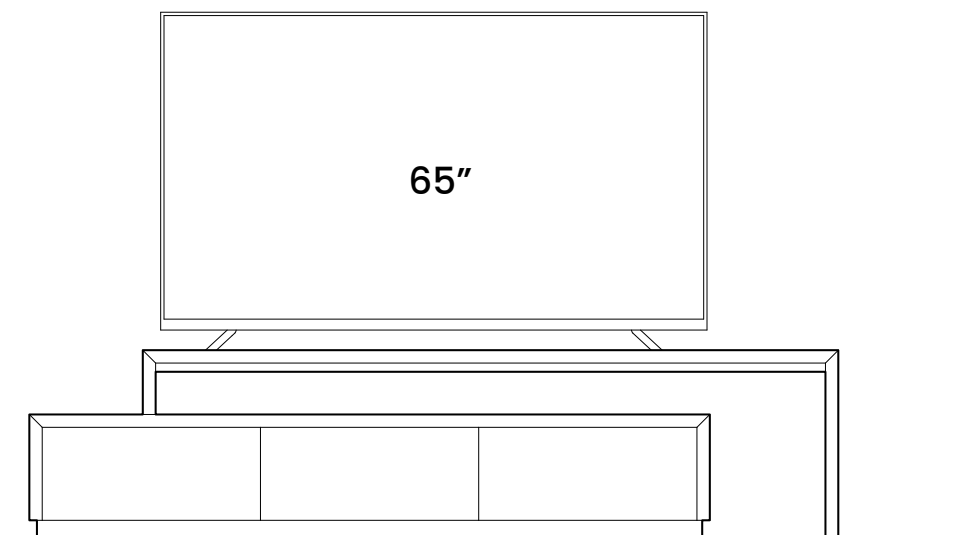

#### NACO IDEAL TV SETUP GUIDELINES

- For an ideal TV viewing height make sure the TV center is at or just below your seated eye level.
- For most people a comfortable seated eye level height is around 1080mm from the ground.
- A TV's optimal viewing distance is calculated by multiplying the TV diagonal size by 1.5 times.
- For a 50 to 65 inch TV an optimal viewing range is between 2000mm and 2500mm from the TV.

# NANNUP ENTERTAINMENT UNIT

## 2000mm UNIT | SIZING GUIDE



### UNIT DIMENSIONS

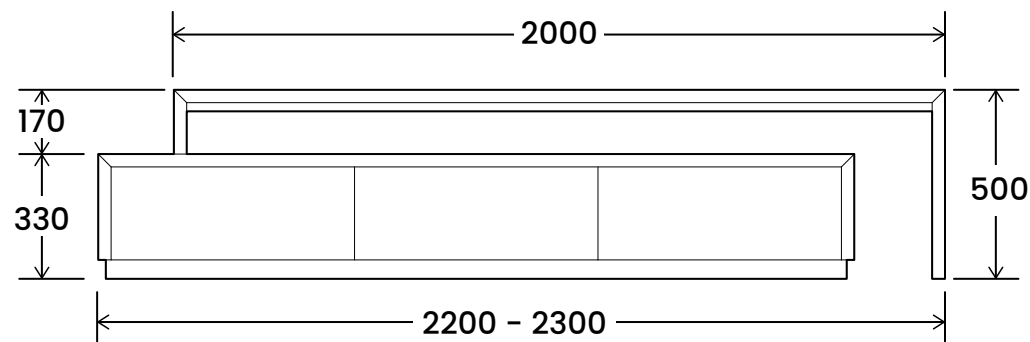

### 55" TV | 2000mm + 200mm

- For a 55" TV we would recommend not going smaller than a 2000mm unit.
- With a small extension of the riser the unit is made to be 1.6 times wider than the TV.
- Based on the golden ratio this size is the perfect balance between the size of the unit and the TV.
- This unit will allow you to upgrade your TV in the future with its ability to extend.

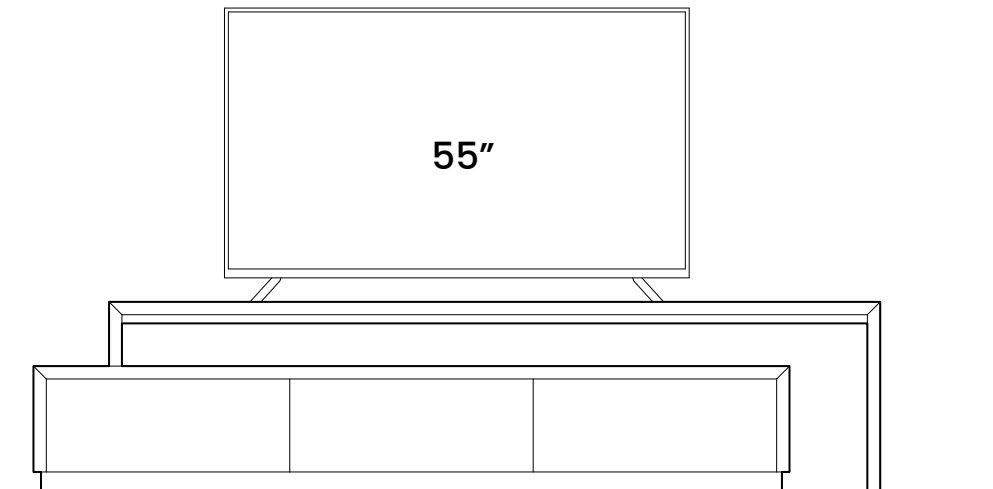

### 65" TV | 2000mm + 250mm

- As you upgrade your TV to a larger size the ability to extend the unit shows its potential.
- With a small extension of the riser the unit is made to be 1.6 times wider than the TV.
- Based on the golden ratio this size is the perfect balance between the size of the unit and the TV.
- This will allow you to keep the special items you have placed on your unit on display.

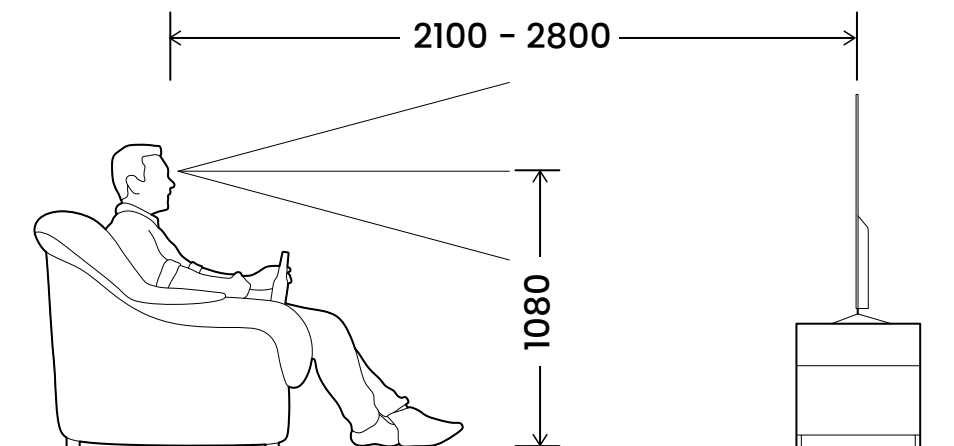
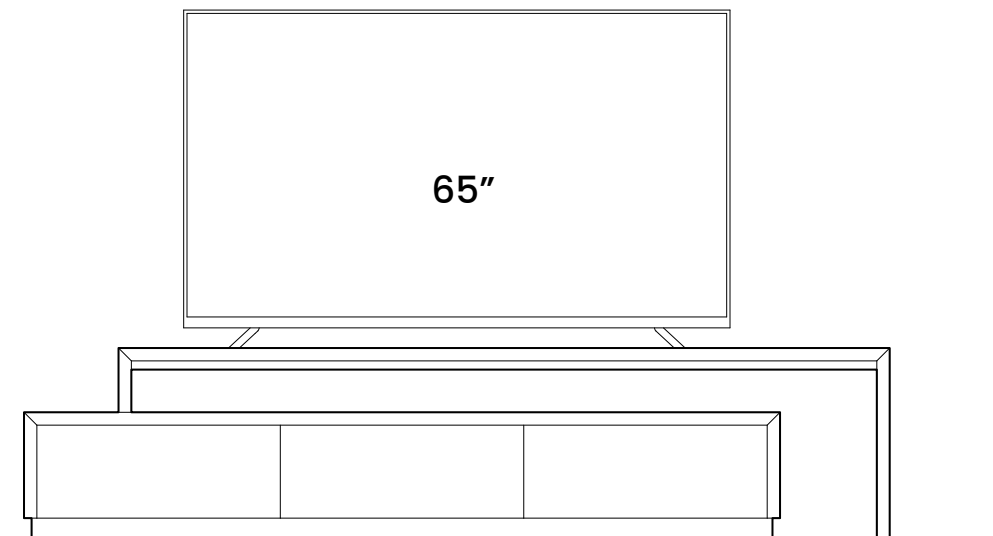

### NACO IDEAL TV SETUP GUIDELINES

- For an ideal TV viewing height make sure the TV center is at or just below your seated eye level.
- For most people a comfortable seated eye level height is around 1080mm from the ground.
- A TV's optimal viewing distance is calculated by multiplying the TV diagonal size by 1.5 times.
- For a 55 to 75 inch TV an optimal viewing range is between 2100mm and 2800mm from the TV.

### 75" TV | 2000mm + 300mm

- As you upgrade your TV to a larger size the ability to extend the unit shows its potential.
- With a small extension of the riser the unit is made to be 1.6 times wider than the TV.
- Based on the golden ratio this size is the perfect balance between the size of the unit and the TV.
- This will allow you to keep the special items you have placed on your unit on display.

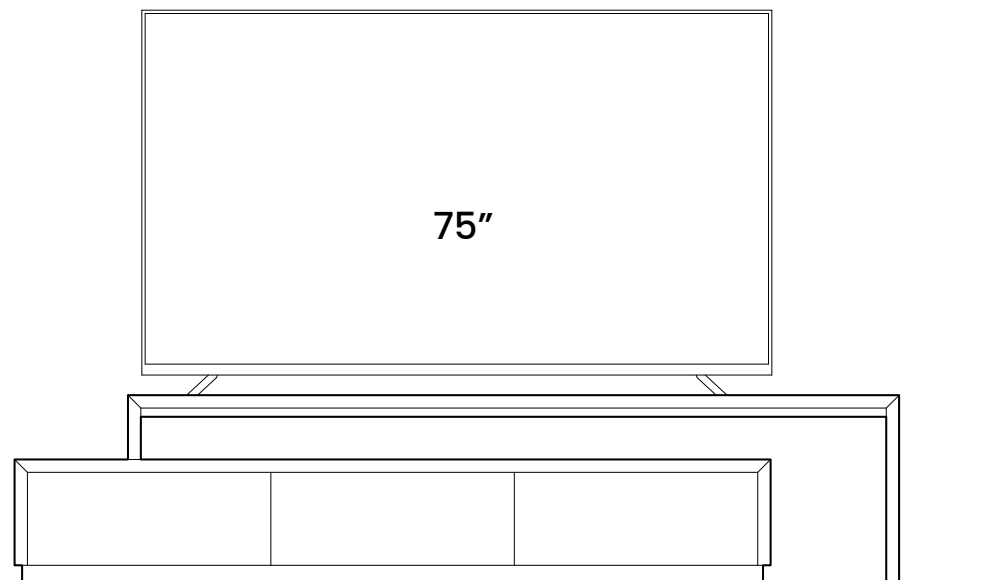

## NANNUP ENTERTAINMENT UNIT

### 2400mm UNIT | SIZING GUIDE

#### UNIT DIMENSIONS

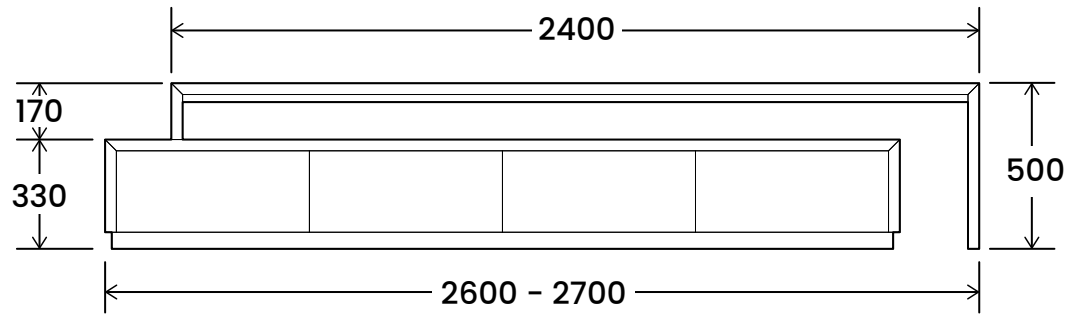

#### 65" TV | 2400mm + 200mm

- For a 65" TV we would recommend not going smaller than a 2400mm unit.
- With a small extension of the riser the unit is made to be 1.6 times wider than the TV.
- Based on the golden ratio this size is the perfect balance between the size of the unit and the TV.
- This unit will allow you to upgrade your TV in the future with its ability to extend.

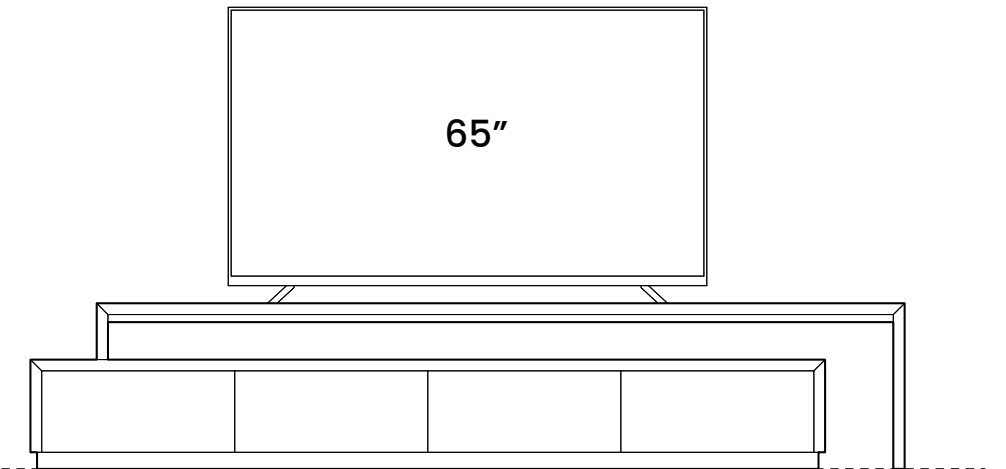

#### 75" TV | 2400mm + 250mm

- As you upgrade your TV to a larger size the ability to extend the unit shows its potential.
- With a small extension of the riser the unit is made to be 1.6 times wider than the TV.
- Based on the golden ratio this size is the perfect balance between the size of the unit and the TV.
- This will allow you to keep the special items you have placed on your unit on display.

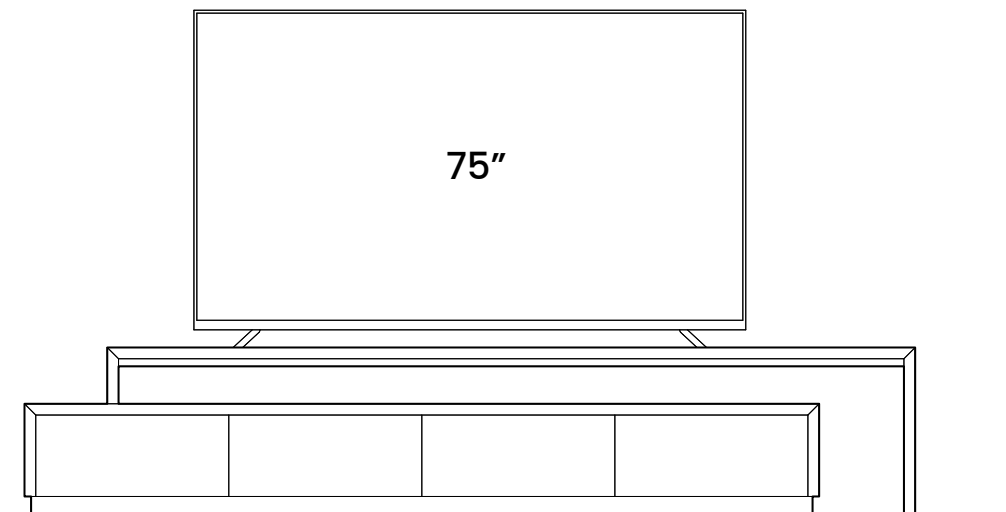

#### 85" TV | 2400mm + 300mm

- As you upgrade your TV to a larger size the ability to extend the unit shows its potential.
- With a small extension of the riser the unit is made to be 1.6 times wider than the TV.
- Based on the golden ratio this size is the perfect balance between the size of the unit and the TV.
- This will allow you to keep the special items you have placed on your unit on display.

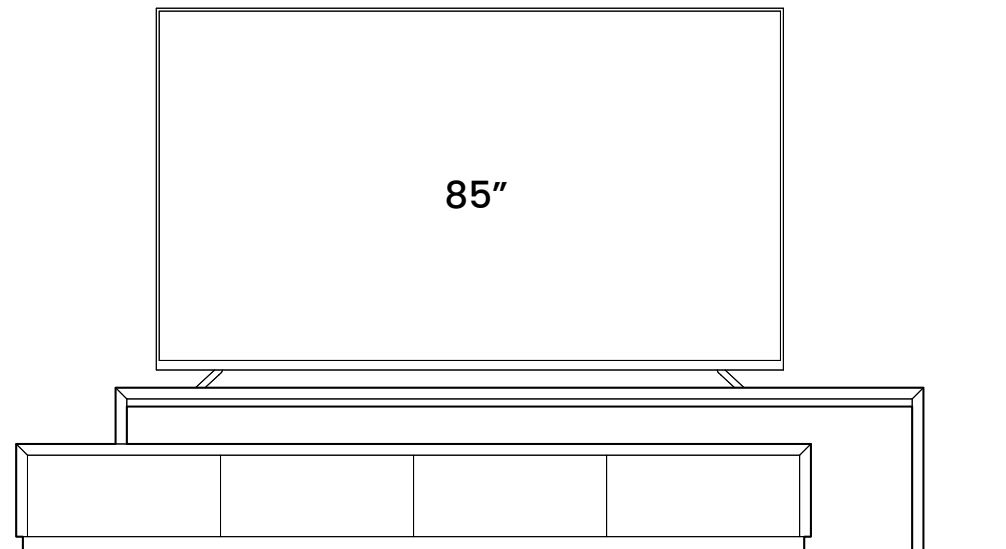

#### NACO IDEAL TV SETUP GUIDELINES

- For an ideal TV viewing height make sure the TV center is at or just below your seated eye level.
- For most people a comfortable seated eye level height is around 1080mm from the ground.
- A TV's optimal viewing distance is calculated by multiplying the TV diagonal size by 1.5 times.
- For a 65 to 85 inch TV an optimal viewing range is between 2500mm and 3000mm from the TV.

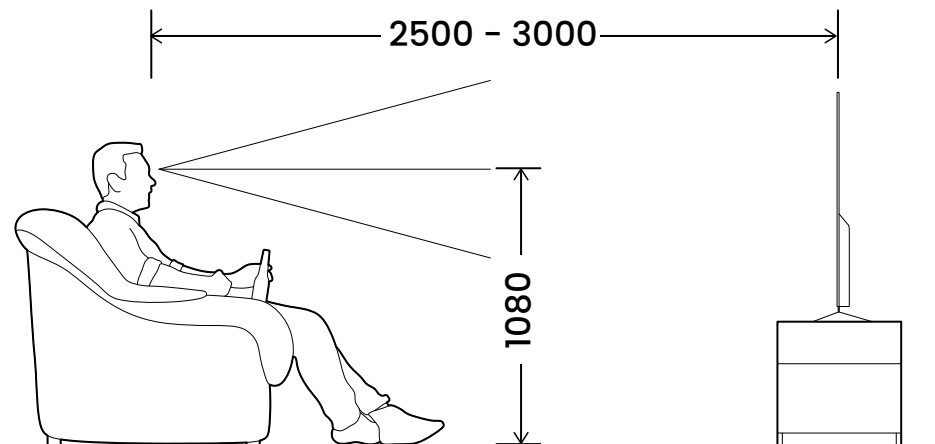

# S

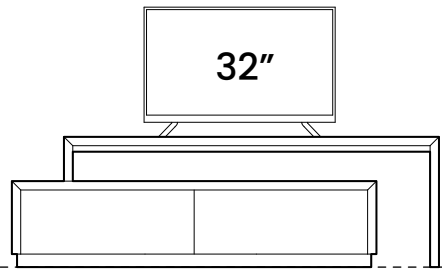
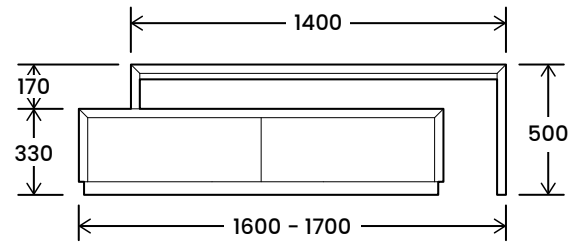

# M

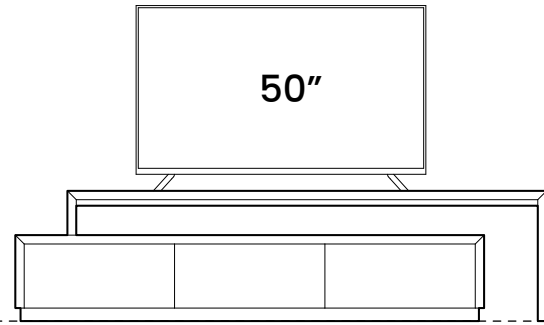
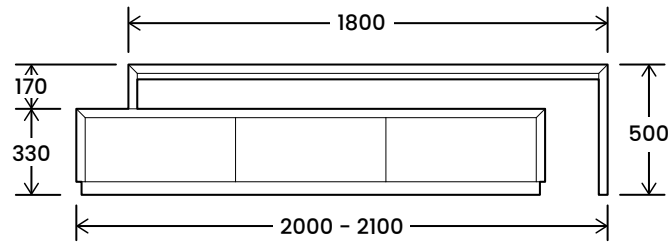

# L

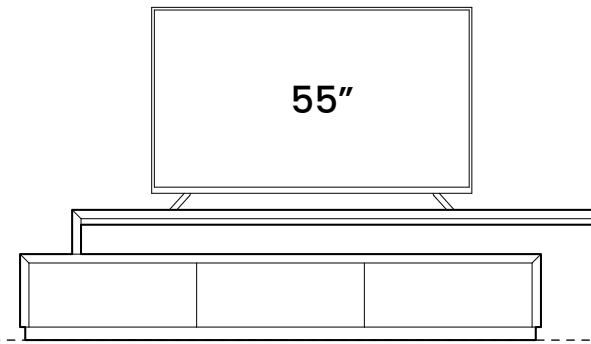
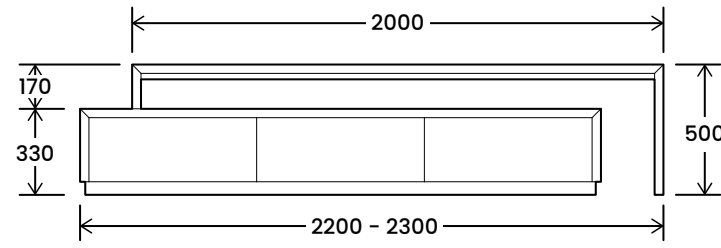

# XL

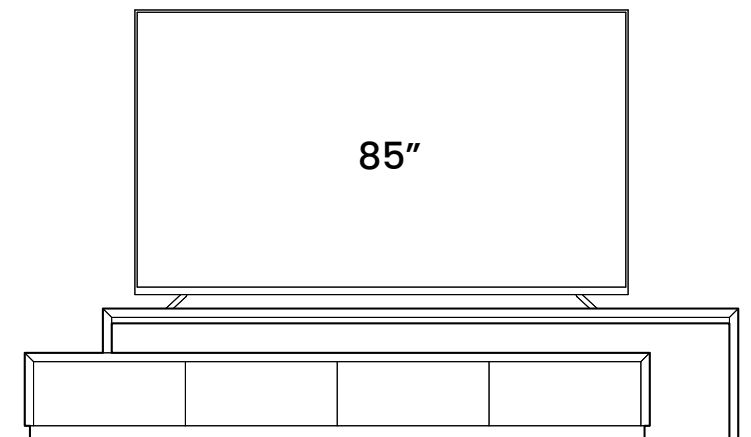
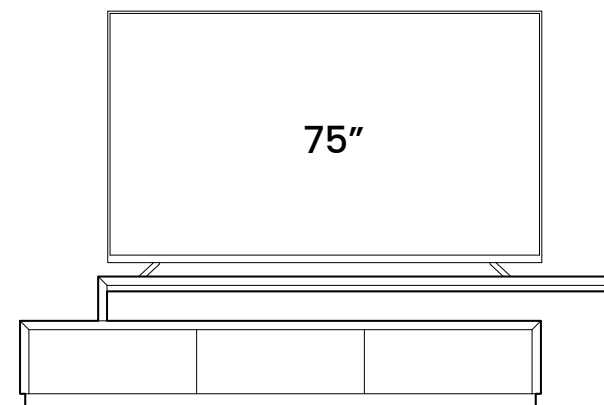
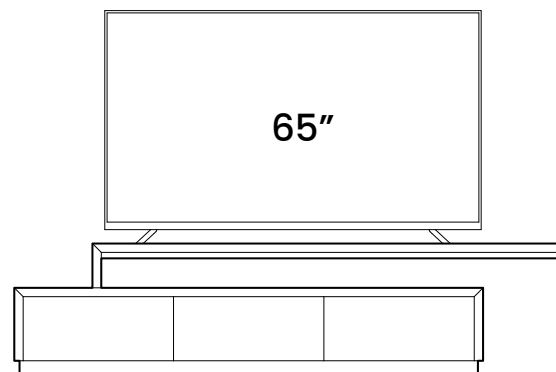
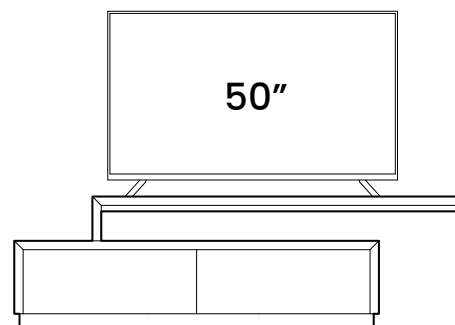
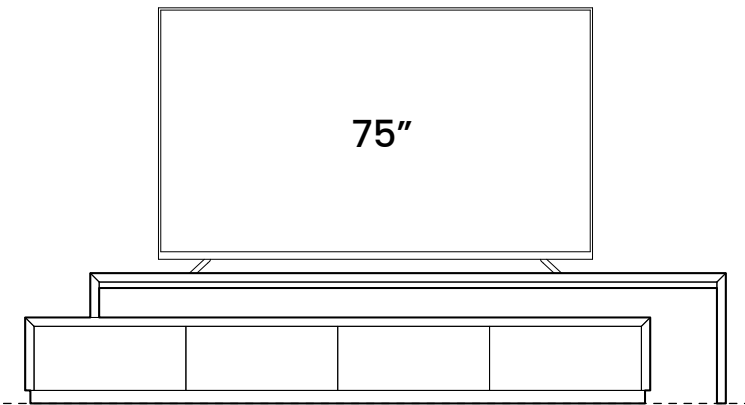
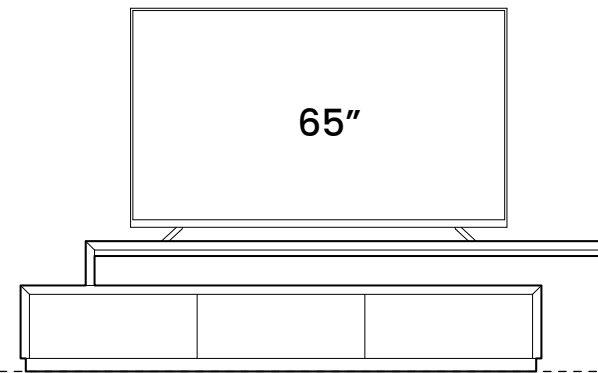
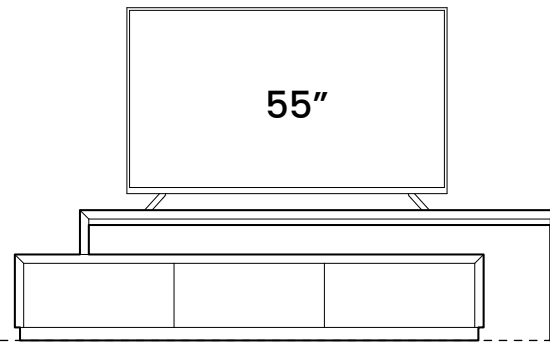
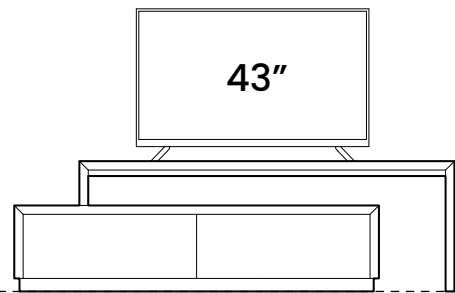
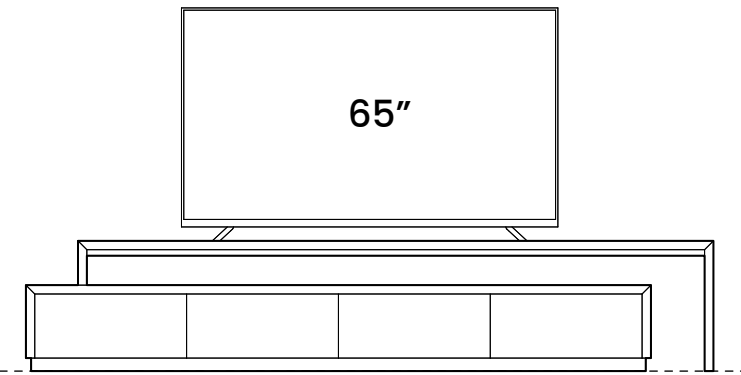
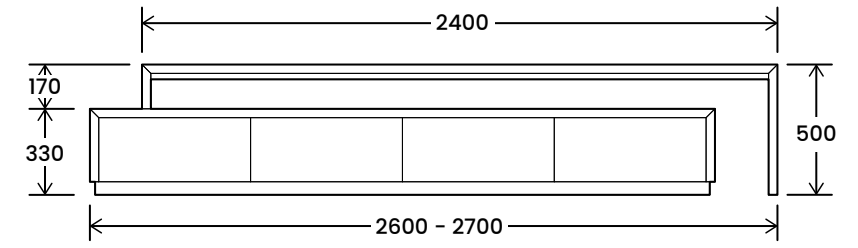

# NANNUP ENTERTAINMENT UNIT

LIVING ROOM

ONE UNIT, ENDLESS POSSIBILITIES

## A Unit for Film Lovers

- Maximized storage of DVD and BluRay collections with space for over 50 movies per drawer.
- Space to tuck away BluRay players and maintain the smooth operation of IR remotes.
- Room to display memorabilia from all your favorite movies and shows.
- Inset backing and cable guides allow simple and effective cable management.

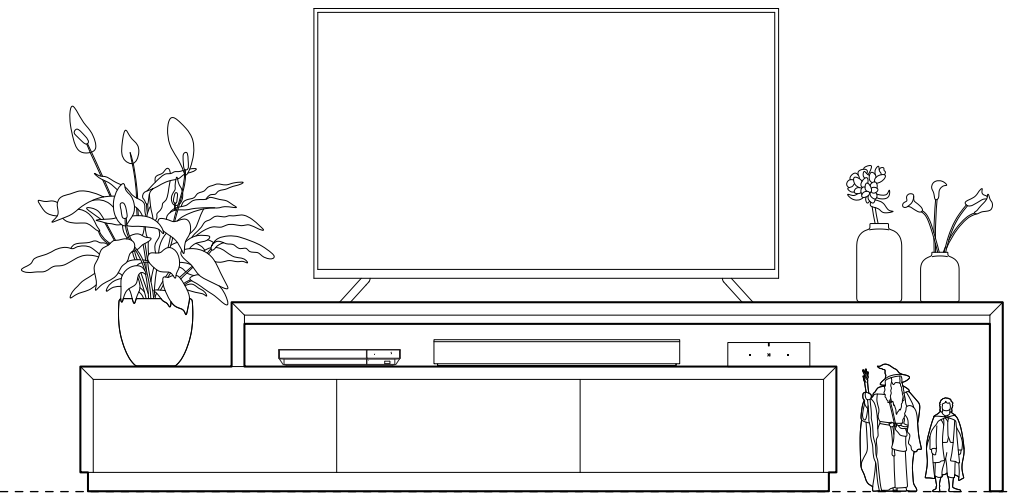

## A Unit for Video Game Fans

- Maximized storage of video game collections with space for over 50 games per drawer.
- Space to tuck away consoles and all of their related controllers with ease of access.
- Room to display memorabilia from all your favorite game series.
- Inset backing and cable guides allow simple and effective cable management.

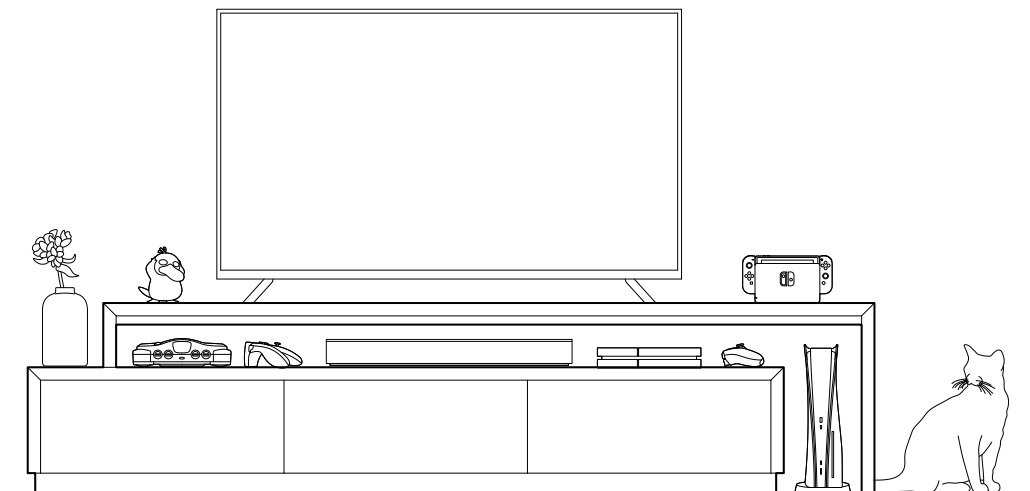

## A Unit for Audio Fanatics

- Maximized storage of audio collections with space for Vinyl to tuck into and drawers for CDs.
- Space to tuck away amplifiers and audio equipment maintain airflow.
- Room to hold equipment like turntables to allow for ease of access whenever you need.
- Inset backing and cable guides allow simple and effective cable management.

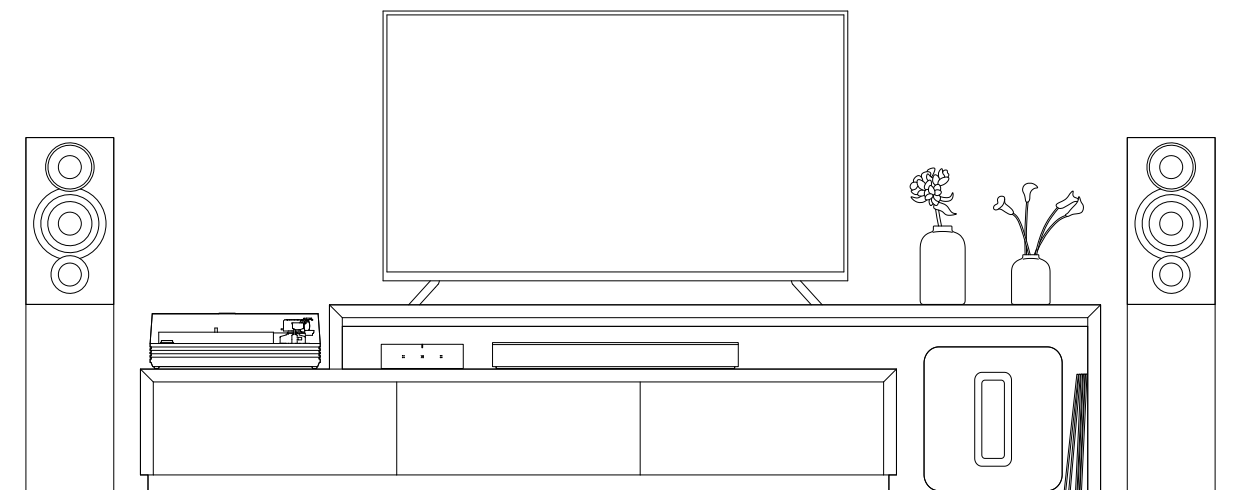

All units shown are 2000mm wide with a 55" TV