

User's Manual

Switch Unit Integrated Type Cycle Computer



Contents

IMPORTANT NOTICE	3
Important safety information	4
SHIMANO STEPS battery management systems and compatibility	5
Notice	6
Regular inspections before riding the bicycle	7
Booklet structure	8
Names and functions of parts	9
Names and functions of parts	9
Notation method for operations	10
Installing and removing the cycle computer	11
Installing and removing the cycle computer	11
Basic operation	12
Turning the power ON/OFF	12
Viewing the screen.....	12
Turning the light ON/OFF	15
Switching the traveling data display	15
Making walking and pushing the bicycle easy (walk assist)	17
Changing settings	19
Changing settings	19
Troubleshooting	20
Gear shifting adjustment with the electronic gear shifting unit [ADJUST]....	20
When gear shifting operation is impossible.....	20
Error/warning indication	20
When a problem occurs.....	22



IMPORTANT NOTICE

- Contact the place of purchase or a distributor for information on installation, adjustment, and replacement of the products which are not found in the user's manual. A dealer's manual for professional and experienced bicycle mechanics is available on our website (<https://si.shimano.com>).
- Please observe the appropriate rules and regulations of the country, state or region in which you conduct your business as a dealer.

For safety, be sure to read this user's manual thoroughly before use, follow it for correct use, and store it so that it can be referenced at any time.

The following instructions must be observed at all times in order to prevent personal injury and physical damage to equipment and surroundings.

The instructions are classified according to the degree of danger or damage which may occur if the product is used incorrectly.

 DANGER	Failure to follow the instructions will result in death or serious injury.
 WARNING	Failure to follow the instructions could result in death or serious injury.
 CAUTION	Failure to follow the instructions could cause personal injury or physical damage to equipment and surroundings.

Important safety information

WARNING

- Do not disassemble or modify the product. This may cause the product to not operate correctly, and you may suddenly fall and be seriously injured.
- Riding precautions
- Do not pay excessive attention to the cycle computer display while riding. Doing so may result in an accident.
 - Make sure that the light is on before riding.
- Safety precautions
- Be sure to remove the battery and charging cable before wiring or attaching parts to the bicycle. Failure to do so may cause an electric shock.
 - Be sure to follow the instructions provided in the manuals when installing the product. It is recommended that you use SHIMANO genuine parts. If bolts and nuts become loose or damaged, the bicycle may suddenly fall over, result in a serious injury.

CAUTION

- Riding precautions
- Observe the instructions in the manual for the bicycle in order to ride safely.
- Safety precautions
- Never modify the system. Doing so may cause a system error.
 - Use the product under the supervision of someone responsible for safety, and only as instructed. Do not allow anyone (including children) with reduced physical, sensual, or mental capacity, or those without experience or knowledge, to use the product.
 - Do not allow children to play near the product.

SHIMANO STEPS battery management systems and compatibility

There are two generations of the SHIMANO STEPS battery management system: first generation and second generation (Gen.2).

This manual only describes products compatible with Gen.2.

With some exceptions, first-generation and Gen.2 products of SHIMANO STEPS components are not compatible with each other. For details, refer to the compatibility information on the SHIMANO product website (<https://productinfo.shimano.com/#/com>).

The Gen.2 battery and compatible battery mount are marked "Gen.2" as indicated in the figure.

Location of terminals

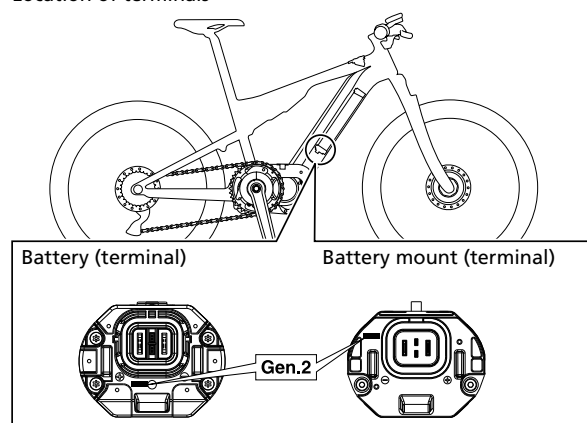

Notice

■ Safety precautions

- If any malfunction or trouble occurs, consult the place of purchase nearest you.
- Be sure to attach dummy plugs to any unused E-TUBE ports.
- For installation and adjustment of the product, consult the place of purchase.
- The components are designed to be fully waterproofed to withstand wet weather riding conditions; however, do not deliberately place them into water.
- Do not clean the bicycle in a high-pressure wash. If water gets into any of the components, operating problems or rusting may result.
- Do not turn the bicycle upside down. There is a risk of damage to the cycle computer and switch unit.
- Handle the components carefully, and avoid subjecting them to strong shock.
- Although the bicycle still functions as a normal bicycle even when the battery is removed, the light will not turn on if it is connected to the electric power system. Be aware that using the bicycle under these conditions will be considered non-observance of the road traffic laws in Germany.

■ Care and maintenance

- Contact the place of purchase for updates of the component software. The most up-to-date information is available on the SHIMANO website.
- Do not use the thinners or harsh solvents to clean the products. Such substances may damage the surface. When cleaning the products, use a cloth moistened with a neutral detergent diluted with water.
- For any questions regarding methods of installation and maintenance, please contact your place of purchase.
- Products are not guaranteed against natural wear and deterioration from normal use and aging.

■ Labels

- Some of the important information contained in this user's manual is also indicated on the device label.

This device complies with part 15 of the FCC Rules. Operation is subject to the following two conditions:
(1) This device may not cause harmful interference, and (2) this device must accept any interference received, including interference that may cause undesired operation.



This symbol on your product, literature, or packaging reminds you that this product must be taken to separate collection at the end of its working life. Do not dispose of this product as unsorted municipal waste but instead take it for recycling. By ensuring the product is disposed correctly, you will help to prevent potential negative consequences for the environment and human health. For info on your nearest recycling point, check with your local waste authority.

Regular inspections before riding the bicycle

Before riding the bicycle, check the following items. If any problems are found, consult your place of purchase or a distributor.

- Does the drivetrain perform gear shifting smoothly?
- Is there any looseness or damage in the component parts?
- Are the components securely installed to the frame/handlebar/stem, etc.?
- Do any abnormal noises occur while riding?
- Is there sufficient charge remaining in the battery?

Booklet structure

SHIMANO STEPS user's manuals are split among several booklets, as described below.

Be sure to read these user's manuals thoroughly before use, and follow them for correct use. Store the user's manuals so that they can be referenced at any time.

The latest user's manuals are available on our website (<https://si.shimano.com>).

Name	Details
SHIMANO STEPS User's Manual	This is the basic user's manual for SHIMANO STEPS. It contains the following content: <ul style="list-style-type: none"> • SHIMANO STEPS quick guide • Basic operations when riding • How to operate assist bicycles that use flat handlebars, such as city, trekking, or MTB type bicycles
SHIMANO STEPS User's Manual for Drop Handlebar Bicycles (separate booklet)	This booklet describes how to operate assist bicycles that use a drop handlebar and are controlled using dual control levers. This should be read along with the SHIMANO STEPS User's Manual.
SHIMANO STEPS Special Battery and Parts User's Manual (Gen.2)	It contains the following content: <ul style="list-style-type: none"> • How to charge and handle the SHIMANO STEPS special battery • How to attach and remove the SHIMANO STEPS special battery to the bicycle • How to read the battery LEDs when charging or during an error
SHIMANO STEPS Cycle Computer User's Manual (clamp band type / bracket installation type / switch unit integrated type)	It contains the following content: <ul style="list-style-type: none"> • Method for configuring settings via the main body buttons and switch unit • Wireless communication method (supported models only)
Switch Unit User's Manual (with LED indicator function / without LED indicator function)	This is the assist switch and shift switch user's manual. It describes switch unit handling and operations.
Satellite System ON/OFF Switch User's Manual	It describes the handling and operations of the satellite system ON/OFF switch.

Names and functions of parts

Names and functions of parts

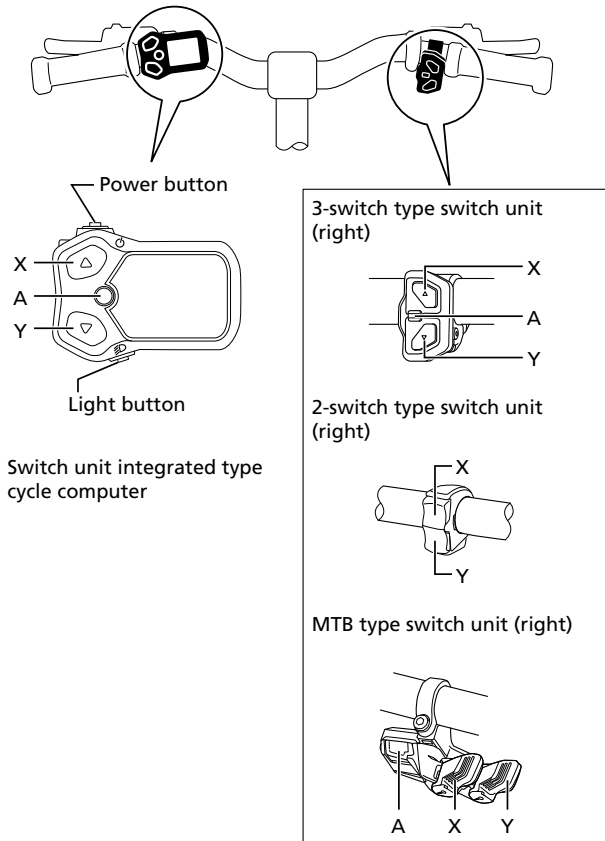

The operation for each switch is indicated below.

Switch unit integrated type cycle computer

X	Increase the level of assistance When in walk assist mode: Disengage walk assist mode * ₁
Y	Decrease the level of assistance Press and hold: Switch to walk assist mode * ₁ When in walk assist mode: Activate walk assist * ₁
A	Switching traveling data display

*₁ Depending on the region of use, you may not be able to use it due to the laws of the region. Refer to " Making walking and pushing the bicycle easy (walk assist) " for details on the walk assist mode.

Switch unit (right)

Names and functions of parts

Notation method for operations

X	Shifting up (3-switch / 2-switch type) Shifting down (MTB type)
Y	Shifting down (3-switch / 2-switch type) Shifting up (MTB type)
A * ₁	Switch between auto and manual gear shifting

*₁ When two auto gear shifting settings are registered, the settings switch in the following order:
Manual > first auto gear shifting setting > second auto gear shifting setting > manual

TECH TIPS

- When connected to the E-TUBE PROJECT, you can change the functions assigned to each switch on the switch unit. Please contact your place of purchase for details.
- Also refer to the " Switch Unit User's Manual ."

Notation method for operations

Subsequent operations of this product are indicated using the following notation.

Notation	Operation
<X>	Indicates an operation for pressing X on the cycle computer.
<A>	Indicates an operation for pressing A on the cycle computer.
[AUTO] (Example) Auto gear shifting	Items displayed on the cycle computer screen are enclosed in square brackets in this manual.

Installing and removing the cycle computer

Installing and removing the cycle computer

For the installation/removal procedure, contact your place of purchase or a distributor.

Basic operation

Turning the power ON/OFF

When the power of this product is turned ON, all components connected to the drive unit are also turned ON (such as assist driving, the electronic gear shifting mechanism, and the lights).

NOTICE

- Before turning the power ON, please refer to the " SHIMANO STEPS Special Battery and Parts User's Manual (Gen.2) " to check the following:
 - The battery is firmly attached to the battery mount.
- The power cannot be turned ON while charging.
- Do not step on the pedal when turning the power ON/OFF. Doing so may cause a system error.

1. Press and hold the power button down until the screen turns on.

When the main power is turned ON, a screen similar to that shown below is displayed, then switches to the main screen.

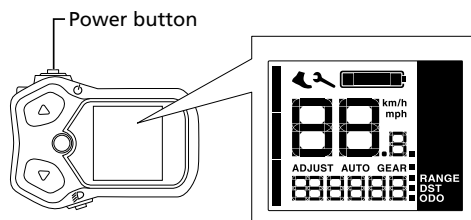

TECH TIPS

- If the bicycle is left unused for 10 minutes or more after turning the power ON, the power automatically turns OFF (auto power OFF function).

Viewing the screen

The items displayed on the main screen differ according to the assist bicycle.

Main screen

Basic operation

Viewing the screen

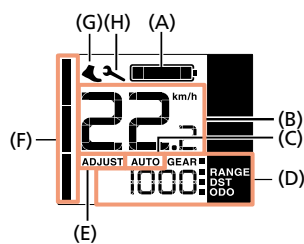

(A)	Battery level indicator (Refer to " Battery level indicator .")
(B)	Current speed Displays the current speed.
(C)	Auto gear shifting display Displayed for auto gear shifting. (Refer to "Auto gear shifting display")
(D)	Traveling data display (Refer to " Switching the traveling data display .")
(E)	ADJUST mode display (Refer to When gear shifting operation is impossible)
(F)	Assist gauge Displays the current assist mode. A mode that provides a stronger level of assistance the longer the length of the displayed gauge.
(G)	Walk assist * ₁ This icon is displayed when switched to walk assist mode.
(H)	Maintenance alert Indicates that maintenance is required. Contact your place of purchase or a distributor if this icon is displayed.

*₁ Depending on the region of use, you may not be able to use it due to the laws of the region. Refer to " Making walking and pushing the bicycle easy (walk assist) " for details on the walk assist mode.

Battery level indicator

The battery level is shown as an icon.

Display	Battery level
	100 - 81%
	80 - 61%
	60 - 41%
	40 - 21%
	20 - 1% * ₁
	0%

Basic operation

Viewing the screen

- * 1 The battery level indicator will flash when the battery level is low if the assist mode is set to something other than [OFF].

TECH TIPS

- The cycle computer uses zero to indicate a battery level where assistance cannot be performed. SHIMANO STEPS provides an amount of battery separate from the assist function for additional equipment such as lights and ABS. Therefore, the above-mentioned battery level may differ from that which can be checked on the battery.

Auto gear shifting display

The auto gear shifting display differs according to whether there are one or two auto gear shifting settings. Refer to the " SHIMANO STEPS User's Manual " for details on the operation for switching to auto gear shifting.

When there is one auto gear shifting setting

[AUTO] is displayed when you switch to auto gear shifting.



When there are two auto gear shifting settings, AUTO1 and AUTO2

- When you switch to AUTO1, "1" (indicating AUTO1) is displayed for approximately one second, then the display returns to normal.



Approximately one second after switching to AUTO1

- When you switch to AUTO2, "2" (indicating AUTO2) is displayed for approximately one second, then the display returns to normal. After the display returns to normal, a dot indicating the AUTO2 mode is displayed.

Basic operation

Turning the light ON/OFF



Approximately one second after switching to AUTO2

Turning the light ON/OFF

If a light is connected to the drive unit, this product can be used to operate the light.

1. Press the light button.

It switches between ON and OFF each time it is pressed.

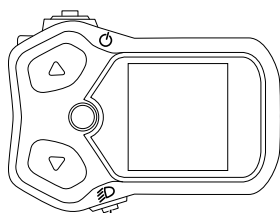

Light button

TECH TIPS

- The light power is linked with the main power. The light cannot be turned ON when the main power is OFF.

Switching the traveling data display

On the main screen, you can check various traveling data in addition to the current speed. The traveling data that can be displayed differs according to the assist bicycle.

Basic operation

Switching the traveling data display

1. On the main screen: Press <A>.

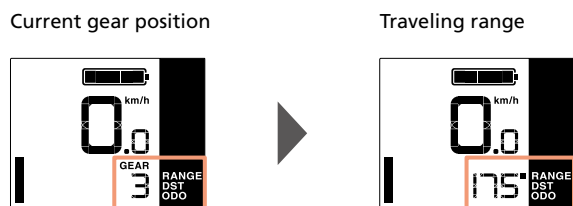

The traveling data switches in the following order each time <A> is pressed.

Display item	Explanation
[GEAR]	Current gear position * 1
[RANGE]	Traveling range * 2
[DST]	Traveling distance
[ODO]	Cumulative distance

- * 1 Only displayed for electronic gear shifting.
- * 2 The traveling range (reference value) for the selected assist mode. The display switches each time the assist mode is switched. The value is not displayed when the assist mode is set to [OFF] or when the walk assist mode is enabled.

TECH TIPS

- If the traveling data display is switched when [ODO] is displayed, the screen will switch back to displaying [GEAR] (for electronic gear shifting) or [RANGE] (for mechanical gear shifting).
- The traveling data display condition that was last displayed is retained even when the power is turned OFF.
- Even when the traveling data display is switched to something other than [GEAR], the screen will display [GEAR] for approximately two seconds when a gear shifting operation is performed.

Resetting the traveling distance

The traveling distance is reset from the main screen.

Basic operation

Making walking and pushing the bicycle easy (walk assist)

1. On the main screen: Press <A>. (Switches the traveling data display to [DST])

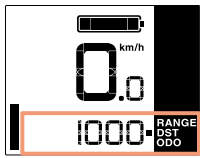

2. Press and hold <A>. (Continue to hold down until the number displayed for [DST] flashes.)
3. When the number displayed for [DST] is flashing: Press <A>.

The traveling data is reset.

TECH TIPS

- If nothing is done for five seconds after the number for [DST] begins flashing, it will stop flashing and the screen will return to the main screen. The display will automatically return to the main screen when the start of traveling is detected.

Making walking and pushing the bicycle easy (walk assist)

Depending on the region of use, you may not be able to use it due to the laws of the region. In this case, the operations described here are disabled.

1. Stop and switch to walk assist mode.

Press and hold Y until it reaches the following state.

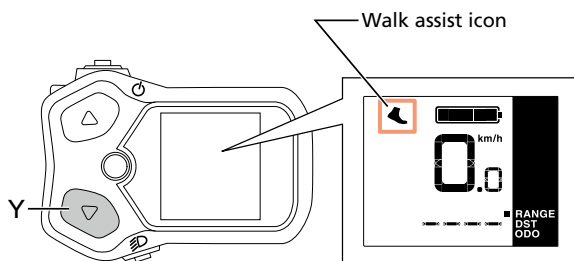

TECH TIPS

- If nothing is done for one minute after switching to walk assist mode, it will switch back to the assist mode that was selected before switching.

Basic operation

Making walking and pushing the bicycle easy (walk assist)

2. Carefully push the bicycle while pressing Y again.

The drive unit operates while Y is pressed to assist you in pushing the bicycle.

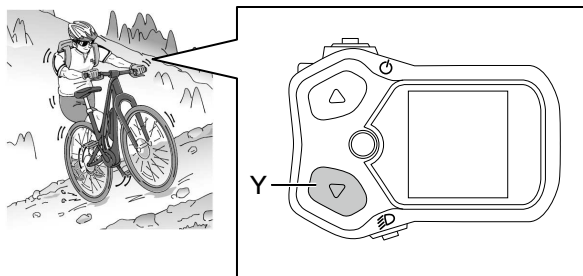

NOTICE

Walk assist operates at a maximum of 6 km/h. Be careful because the bicycle starts moving just by pressing Y.

TECH TIPS

- During electronic gear shifting, the level of assistance of walk assist and speed are controlled by the current gear position.

3. Exit walk assist mode.

Press X to disengage the walk assist mode and clear the walk assist icon from the screen.

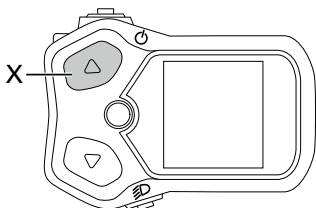

Changing settings

Changing settings

With this product, the following settings can be changed. If you want to change the settings, contact your place of purchase.

- You can switch the display units of speed and distance to km or miles.
- If the bicycle has a Di2 internal geared hub, you can set/change the gear position when starting from a stop.
- You can select to have the backlight of the display always ON, always OFF, or linked to the light.

Troubleshooting

Gear shifting adjustment with the electronic gear shifting unit [ADJUST]

If gear shifting feels abnormal, contact the place of purchase.

When gear shifting operation is impossible

If you are unable to change gears using the electronic gear shifting, check the cycle computer display for the following. Also refer to "Error/warning indication."

When [ADJUST] is displayed

The system has switched to ADJUST (adjustment) mode. Perform the following operation to cancel it.

1. Press <A>

The ADJUST (adjustment) mode is canceled, and the system returns to the main screen.

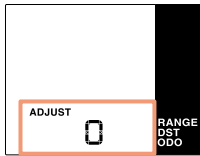

If the walk assist icon is displayed

The system has switched to walk assist mode. Perform the following operation to cancel it.

1. Press <X>

The walk assist mode is canceled and the walk assist icon is no longer displayed on the screen.



Error/warning indication

For details on error/warning codes, check the latest versions below:



<https://si.shimano.com/error>

Error indication

If an error code "E***" (where *** is letters or numbers) is displayed on the entire screen, the product may have malfunctioned.

Refer to the " SHIMANO STEPS Special Battery and Parts User's Manual (Gen.2) " and follow one of the procedures below to reset the display:

- Press the battery power button to turn the power OFF.
- Remove the battery from the battery mount.



NOTICE

- If the situation does not improve even after turning the power back ON, stop using the bicycle and consult with the place of purchase or a distributor as soon as possible.

Warning indication

If a warning code "W***" (where *** is letters or numbers) is displayed on the screen, the product may have a temporary problem. Functionality may be limited while the code is displayed.

If the situation is improved, this indication will disappear. If the situation does not improve, contact the place of purchase as soon as possible.

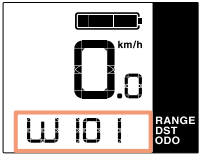

When a problem occurs

The FAQ for the SHIMANO STEPS series can be accessed with the following:



<https://bike.shimano.com/faq/STP0A>

SHIMANO



SHIMANO NORTH AMERICA BICYCLE, INC.
One Holland, Irvine, California 92618, U.S.A. Phone: +1-949-951-5003

SHIMANO EUROPE B.V.
High Tech Campus 92, 5656 AG Eindhoven, The Netherlands Phone: +31-402-612222

MADISON (A DIVISION OF H.YOUNG (OPERATIONS) LTD)
Roebuck Way, Knowlhill, Milton Keynes, Buckinghamshire, MK5 8HL, United Kingdom

SHIMANO INC.
3-77 Oimatsu-cho, Sakai-ku, Sakai City, Osaka 590-8577, Japan

Please note: specifications are subject to change for improvement without notice. (English)
© Nov. 2022 by SHIMANO INC. ITP